

This drawing is confidential and must not be reproduced or used without the consent of EXM

Ce dessin est confidentiel et ne doit pas être reproduit ou utilisé sans le consentement de EXM

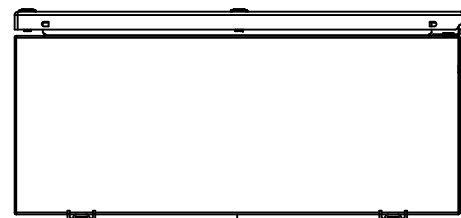

TOP

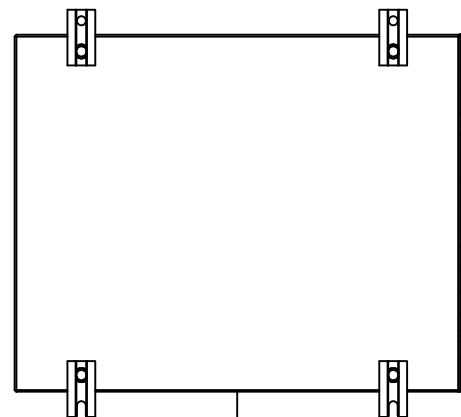

BACK

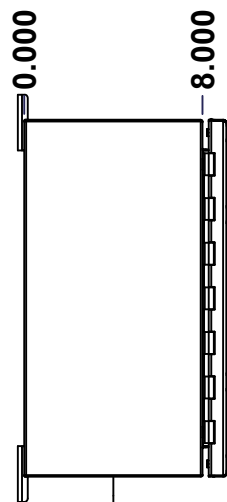

LEFT

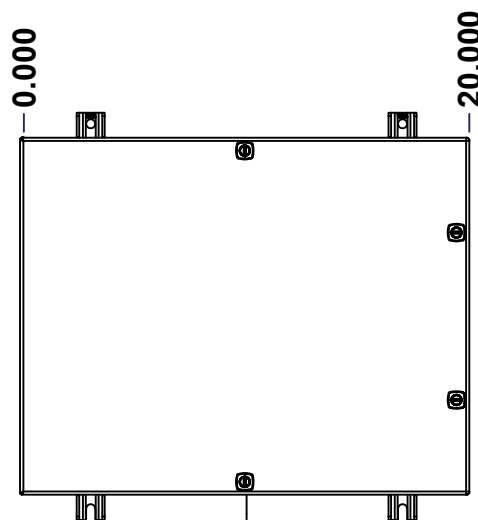

FRONT

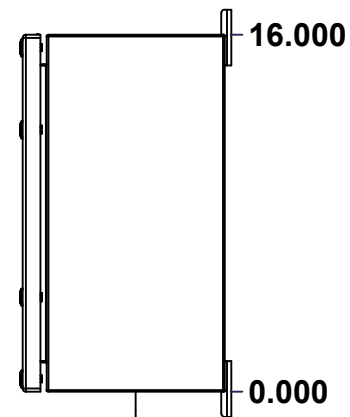

RIGHT

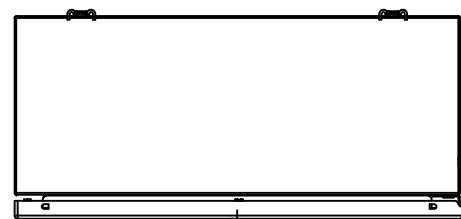

BOTTOM

No.	Revisions	Date	By/Par

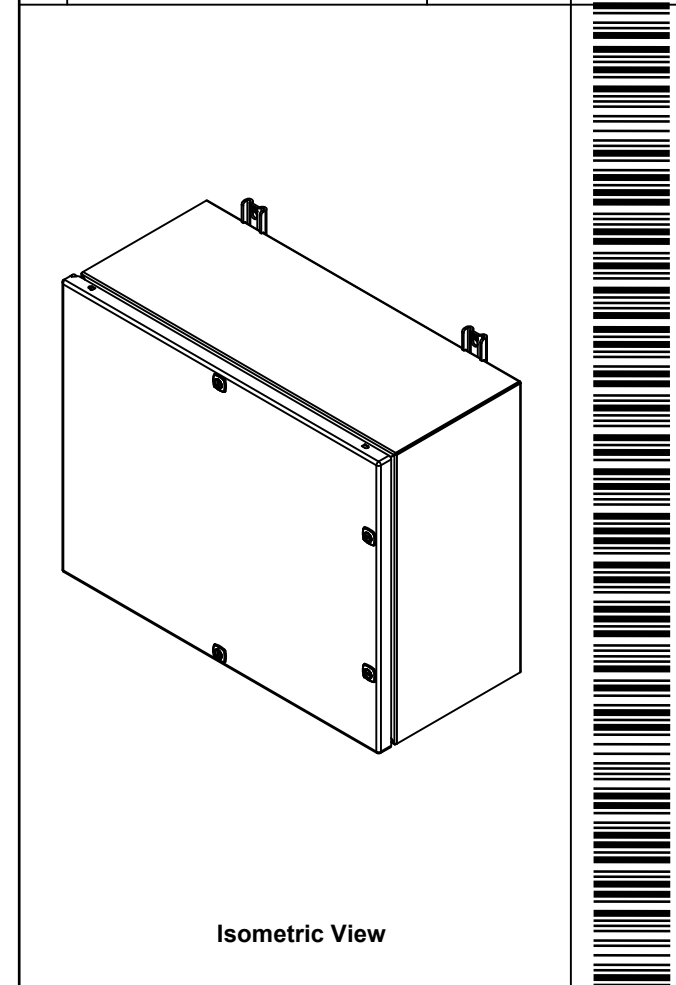

Isometric View

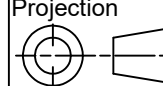

 Tél: (450) 979-4373 Fax: (450) 979-4626 www.exmweb.com		Flatness Aplatissement Max 3.0mm Projection 
Customer Client	Date	
Drawn By Dessiné Par	BoxCad: BoxCad	Date 04-Feb-20
Material Matière	16 Ga H.R.P. & O. (1.4mm)	
Color Couleur	Asa-61 Grey	Finish Finis Smooth
Description	Detail Rev.	
5412ESEL 16" x 20" x 8" Assembly		
Part Number Numéro Pièce	Rev.	1
5412ESEL162008	0	2

SEE BILL OF MATERIAL ON LAST PAGE

This drawing is confidential and must not be reproduced or used without the consent of EXM

Ce dessin est confidentiel et ne doit pas être reproduit ou utilisé sans le consentement de EXM

NOTE	
ITEM	DESCRIPTION
1	NEMA 4/12 Enclosure
2	C/W Standard ground studs on box and cover
3	W/O Standard door stiffener
4	C/W Standard inner panel (Sold separately)
5	C/W Standard inner panel mounting studs
6	C/W 885 ESMF1_OPEN Sold separately (Kit)
7	C/W 885 ESMF1_CLOSE Sold separately (Kit)

No.	Revisions	Date	By/Par

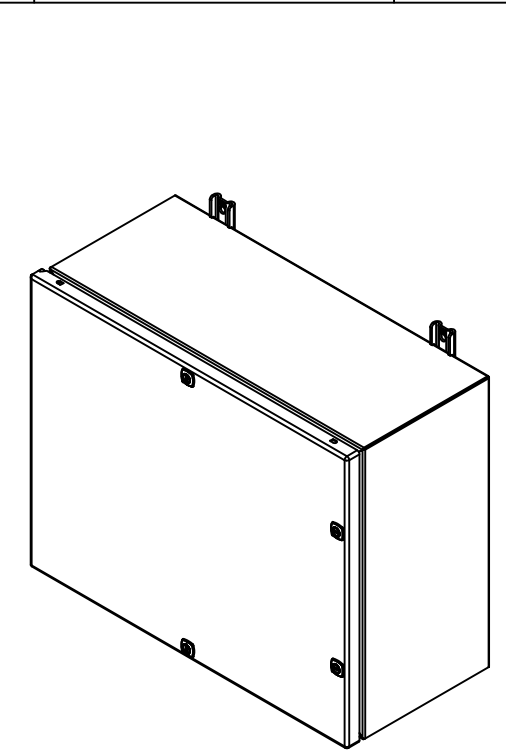

Isometric View



Tél: (450) 979-4373
 Fax: (450) 979-4626
www.exmweb.com

Flatness
Aplatissement
Max 3.0mm
Projection

Customer Client
 Drawn By Dessiné Par BoxCad: BoxCad
 Date 04-Feb-20

Material Matière 16 Ga H.R.P. & O. (1.4mm)

Color Couleur Asa-61 Grey
 Finish Fini Smooth

Description 5412ESEL 16" x 20" x 8" Assembly
 Detail Rev.

Part Number Numéro Pièce
5412ESEL162008
 Rev. 0

Qty	Part Number	Rev	Description
1	STK-K-01800	5	5412 ES Accessory Kit
1	880 PP	6	Self Adhesive Print Pocket
1	885SP2016G	0	885SP 20" x 16" Inner Panel Part
1	MC_5412ESEL162008C	0	5412ESEL 16" x 20" Cover
4	STK-Q-07310	2	Flange Lock Nut M8
4	STK-Q-07610	8	M8 Plastic Spacer 22.2mm
1	MC_5412ESEL162008B	0	5412ESEL 16" x 20" x 8" Body
2	STK-Q-04050-10	8	M6 x 10mm Hexagon Socket Head Machine Screw with Nyseal
Parts List			

PACKING		
ITEM	QTY	DESCRIPTION
Cardboard sleeve	2	Top and Bottom
Cardboard strip	2	Between back of enclosure and inner panel
Plastic bag	1	To protect cover surface and inside gasket
Plastic strap - Black	2	To Squeeze the 2 cardboard sleeve together
Packaging label	1	White label with product number

This drawing is confidential and must not be reproduced or used without the consent of EXM

Ce dessin est confidentiel et ne doit pas être reproduit ou utilisé sans le consentement de EXM

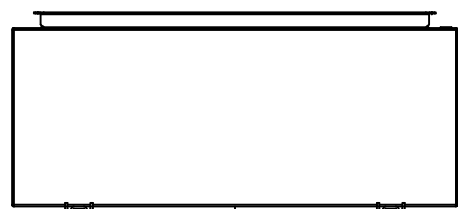

TOP

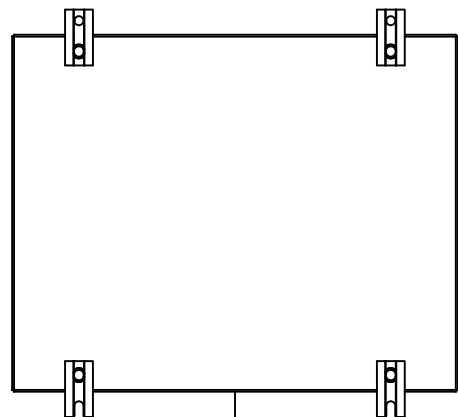

BACK

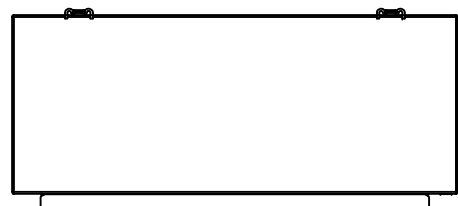

BOTTOM

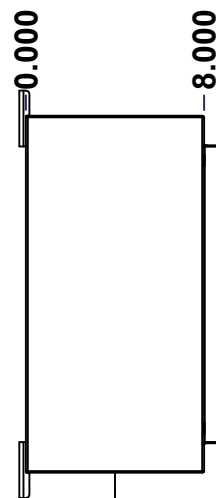

LEFT

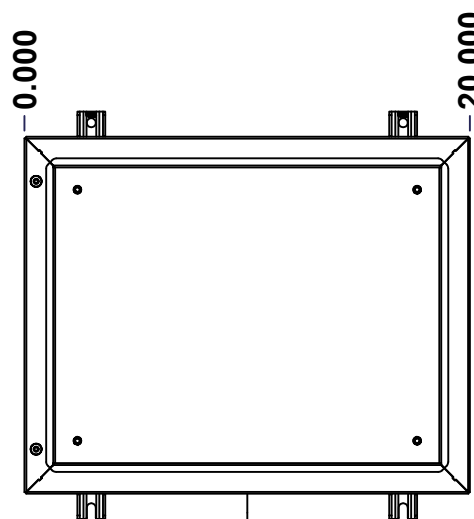

FRONT

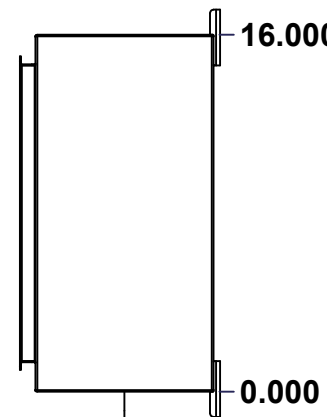

RIGHT

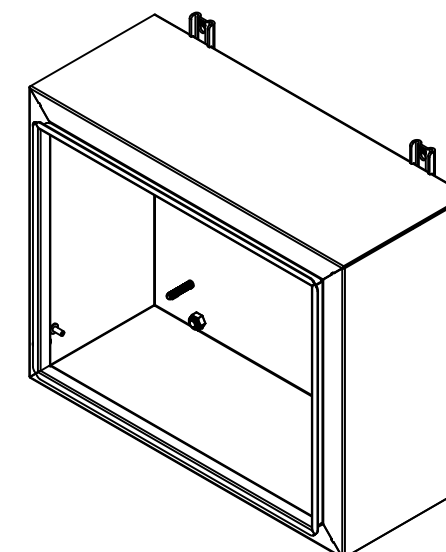

Isometric View



Tél: (450) 979-4373
 Fax: (450) 979-4626
www.exmweb.com

Flatness
Aplatissement

Max 3.0mm

Projection

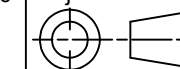

Customer Client	Date
Drawn By / Dessiné Par: BoxCad: BoxCad	Date: 04-Feb-20

Material / Matière: 16 Ga H.R.P. & O. (1.4mm)

Color / Couleur: Asa-61 Grey	Finish / Fini: Smooth
------------------------------	-----------------------

Description: 5412ESEL 16" x 20" x 8" Body	Detail Rev.
---	-------------

Part Number / Numéro Pièce: 5412ESEL162008B	Rev. 0	1 / 7
---	--------	-------

SEE BILL OF MATERIAL ON LAST PAGE

This drawing is confidential and must not be reproduced or used without the consent of EXM

Ce dessin est confidentiel et ne doit pas être reproduit ou utilisé sans le consentement de EXM

STANDARD FEATURES ARE NOT LISTED IN THIS HOLE TABLE

HOLE TABLE - LEFT VIEW (CUSTOM FEATURE ONLY)

CUT-OUT	XDIM	YDIM	DESCRIPTION
1	6.500	2.000	GND STUD M6 x 16mm (Inside)

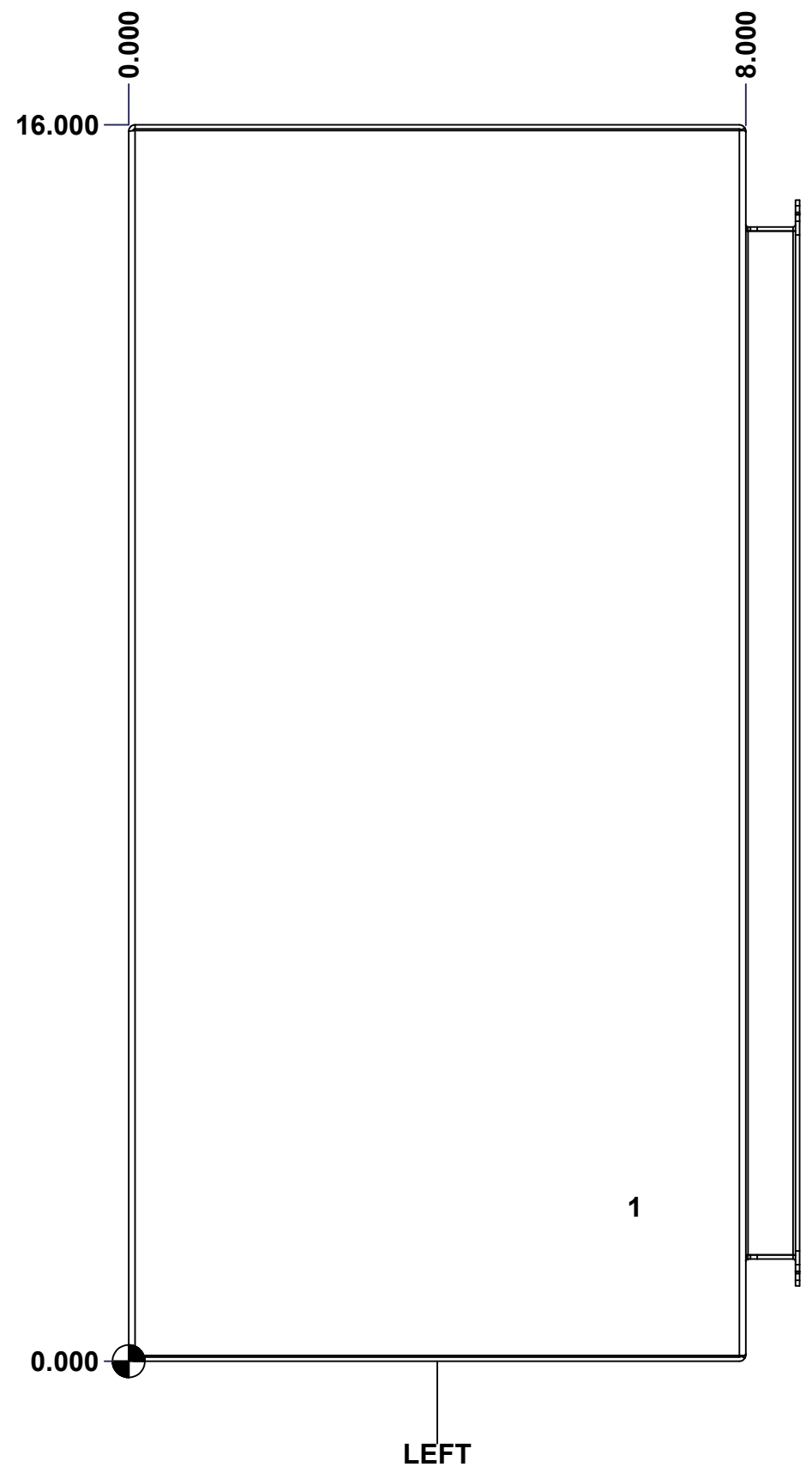

	Description		Status	
	5412ESEL 16" x 20" x 8" Body			
	Part Number		Rev.	5
	5412ESEL162008B		0	7

This drawing is confidential and must not be reproduced or used without the consent of EXM

Ce dessin est confidentiel et ne doit pas être reproduit ou utilisé sans le consentement de EXM

STANDARD FEATURES ARE NOT LISTED IN THIS HOLE TABLE

HOLE TABLE - BACK VIEW (CUSTOM FEATURE ONLY)

CUT-OUT	XDIM	YDIM	DESCRIPTION
1	2.375	2.375	IP STUD M8 x 35mm (Inside)
2	2.375	13.625	IP STUD M8 x 35mm (Inside)
3	17.625	13.625	IP STUD M8 x 35mm (Inside)
4	17.625	2.375	IP STUD M8 x 35mm (Inside)

5	17.000	0.000	FOOT 885 ESMF1_OPEN
6	3.000	0.000	FOOT 885 ESMF1_OPEN
7	17.000	16.000	FOOT 885 ESMF1_CLOSE
8	3.000	16.000	FOOT 885 ESMF1_CLOSE

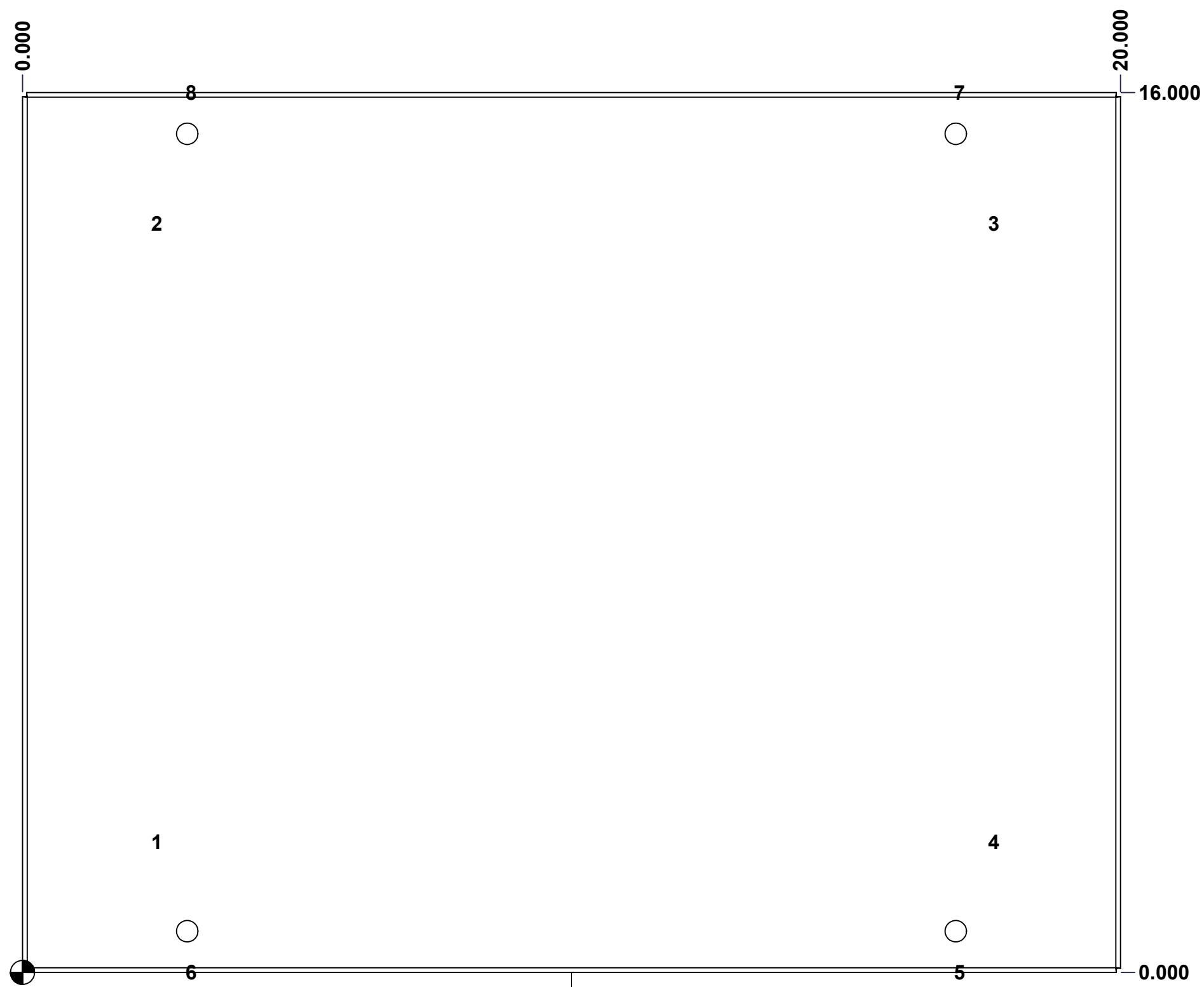

BACK

	Description	Status	
	5412ESEL 16" x 20" x 8" Body		
	Part Number	Rev.	6
	5412ESEL162008B	0	7

This drawing is confidential and must not be reproduced or used without the consent of EXM

Ce dessin est confidentiel et ne doit pas être reproduit ou utilisé sans le consentement de EXM

No.	Revisions	Date	By/Par

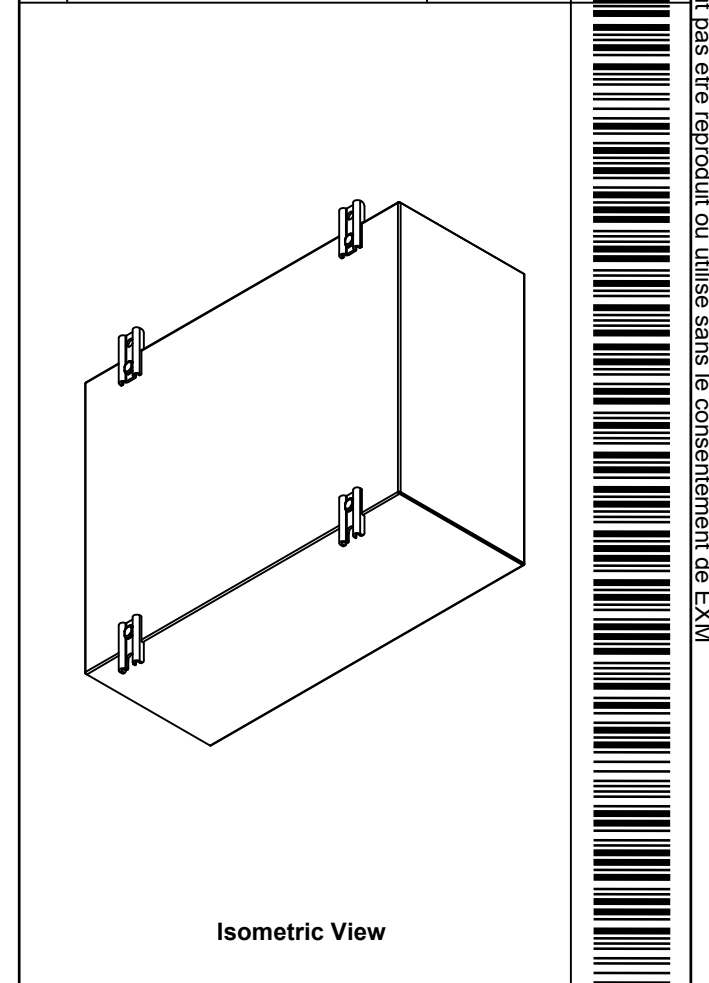

Qty	Part Number	Rev	Description
1	STK-Q-16080	0	Ground Stud M6 x 16mm
2	RIVET_NUT_SS_M6_FH_CE	0	Stainless Steel Rivet Nut M6 (Low Profile Close End)
1	STK-P-02400S	0	Powder Paint (Asa-61 Grey / Smooth)
4	STK-Q-16005	1	Stud M8 x 35 (No Paint Cap Required)
1	MC_5412ESEL162008B-P	0	5412ESEL 16" x 20" x 8" Body Part
2	885 ESMF1_CLOSE	0	885 ESMF1 Mounting Foot (Closed Hole)
2	885 ESMF1_OPEN	0	885 ESMF1 Mounting Foot (Opened Hole)
Parts List			

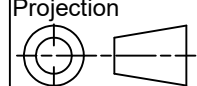
 Tél: (450) 979-4373 Fax: (450) 979-4626 www.exmweb.com		Flatness Aplatissement Max 3.0mm Projection 
Customer Client	Date	
Drawn By Dessiné Par	BoxCad: BoxCad	Date 04-Feb-20
Material Matière	16 Ga H.R.P. & O. (1.4mm)	
Color Couleur	Asa-61 Grey	Finish Fini Smooth
Description		Detail Rev.
5412ESEL 16" x 20" x 8" Body		
Part Number Numéro Pièce	Rev.	7
5412ESEL162008B	0	7

This drawing is confidential and must not be reproduced or used without the consent of EXM

Ce dessin est confidentiel et ne doit pas être reproduit ou utilisé sans le consentement de EXM

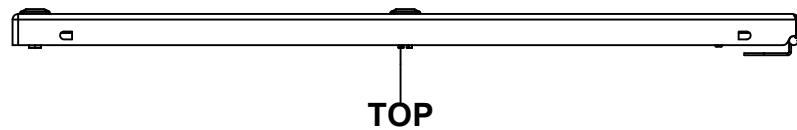

TOP

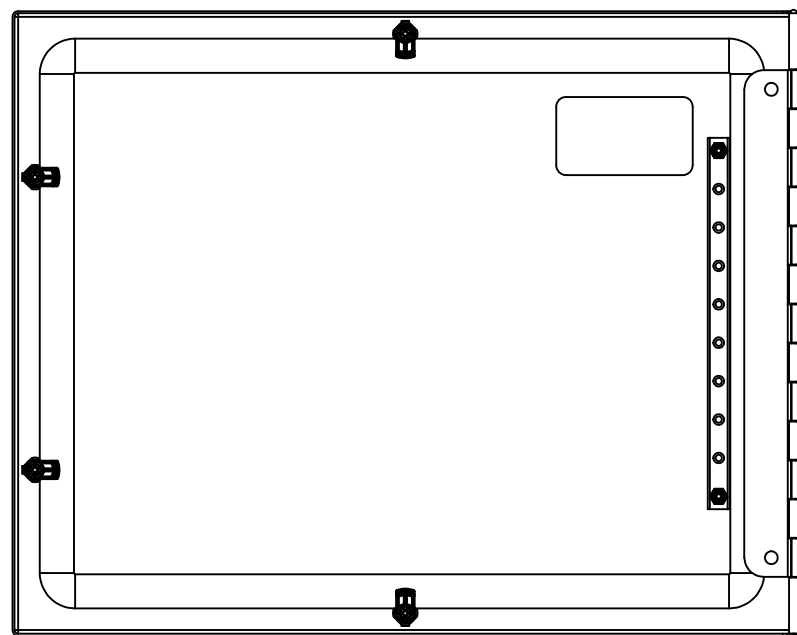

BACK

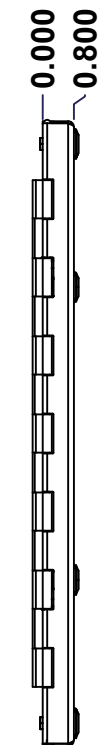

LEFT

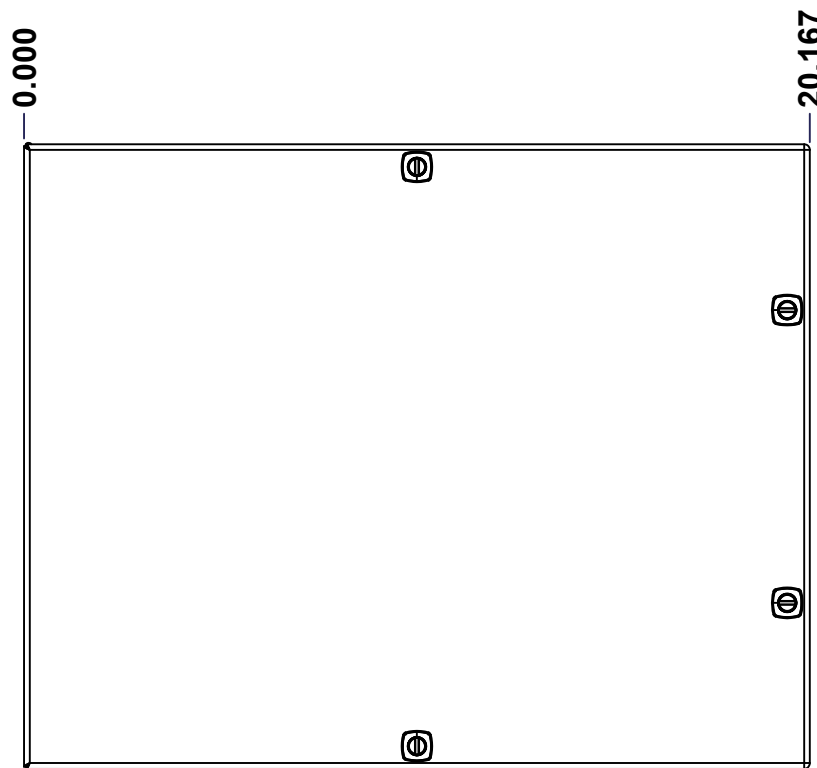

FRONT

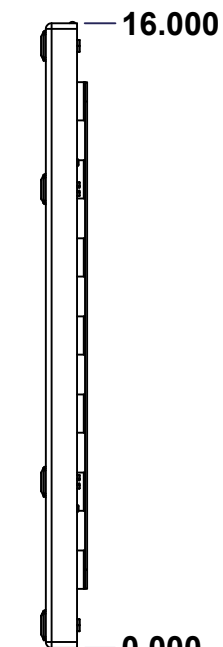

RIGHT

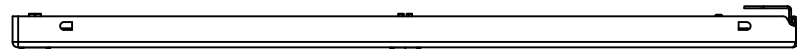

BOTTOM

No.	Revisions	Date	By/Par

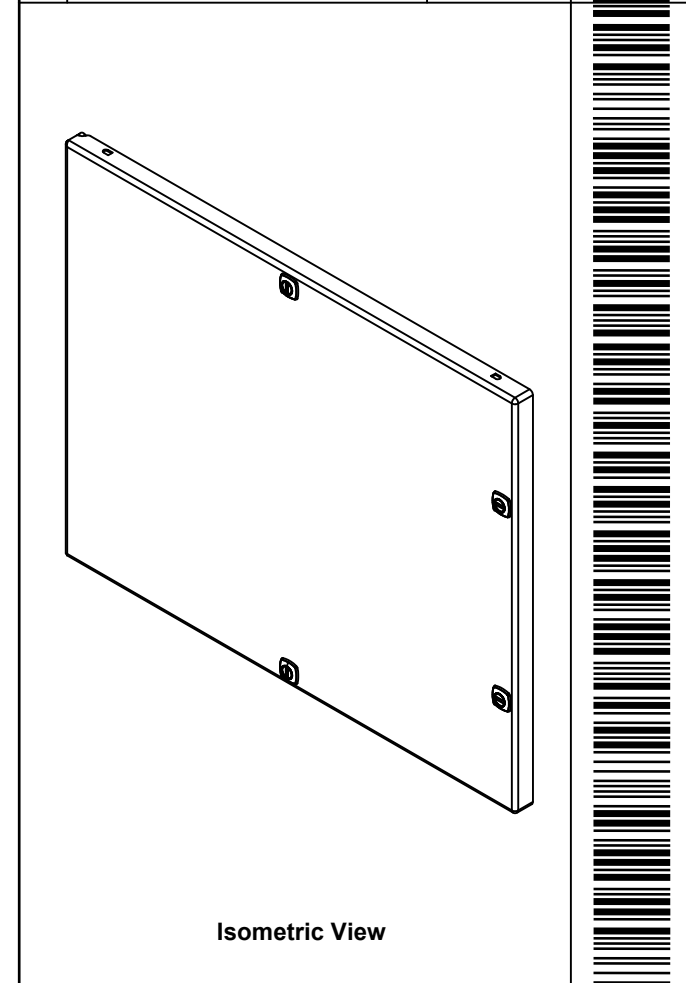

Isometric View

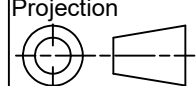

 Tél: (450) 979-4373 Fax: (450) 979-4626 www.exmweb.com		Flatness Aplatissement Max 3.0mm Projection 
Customer Client	Date	
Drawn By Dessiné Par	BoxCad: BoxCad	Date 04-Feb-20
Material Matière	16 Ga H.R.P. & O. (1.4mm)	
Color Couleur	Asa-61 Grey	Finish Finis Smooth
Description	Detail Rev.	
5412ESEL 16" x 20" Cover		
Part Number Numéro Pièce	Rev. 0	1 / 3
5412ESEL162008C		

SEE BILL OF MATERIAL ON LAST PAGE

This drawing is confidential and must not be reproduced or used without the consent of EXM

Ce dessin est confidentiel et ne doit pas être reproduit ou utilisé sans le consentement de EXM

STANDARD FEATURES ARE NOT LISTED IN THIS HOLE TABLE

HOLE TABLE - FRONT VIEW (CUSTOM FEATURE ONLY)

CUT-OUT	XDIM	YDIM	DESCRIPTION
1	2.122	3.571	STUD M6 x 18mm (Inside)
2	2.122	12.429	STUD M6 x 18mm (Inside)

3	4.458	12.803	LABEL_EXM (Inside)
4	19.587	11.750	LOCK 880 SCQ5-SL @ 180.0°
5	19.587	4.250	LOCK 880 SCQ5-SL @ 180.0°
6	10.084	15.420	LOCK 880 SCQ5-SL @ 270.0°
7	10.084	0.580	LOCK 880 SCQ5-SL @ 90.0°

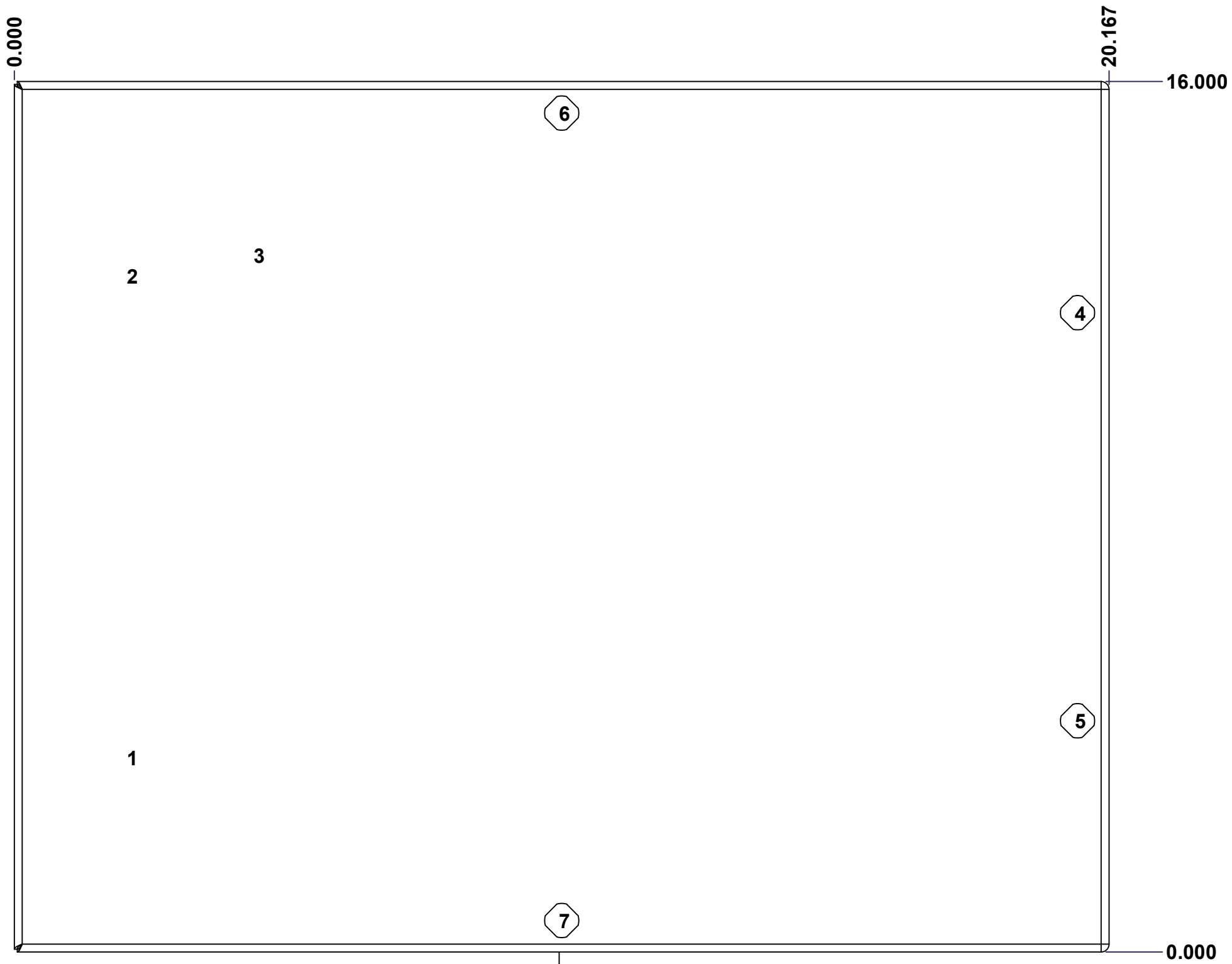

	Description	Status
	5412ESEL 16" x 20" Cover	(NULL)
	Part Number	Rev.
	Numéro Pièce 5412ESEL162008C	0
		2
		3

This drawing is confidential and must not be reproduced or used without the consent of EXM

Ce dessin est confidentiel et ne doit pas être reproduit ou utilisé sans le consentement de EXM

No.	Revisions	Date	By/Par

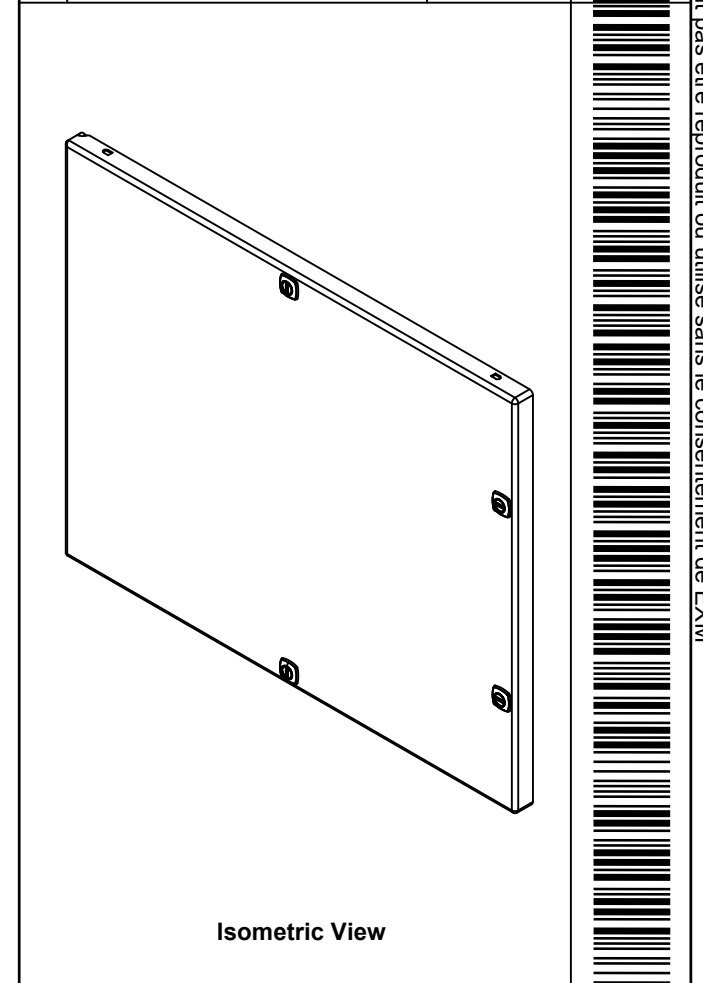

Qty	Part Name	Rev	Description
1	STK-S-00100	0	3.5" x 2" Silver Milar Flexcon Sticker
1	STK-P-02400S	0	Powder Paint (Asa-61 Grey / Smooth)
2	STK-Q-16055	1	M6 x 18mm Stud (No Paint Cap Required)
4	STK-A-79955	2	5412 ESEL Plastic Clip-in 1/4 Turn Lock
1	MC_5412ESEL162008HP-P	0	5412ESEL 16" x 20" Cover Part
1	MC_5412ESEL162008H-P	0	5412ESEL 16" x 20" Cover Part
1	STK-Q-46020-12	5	5412 ES Vertical Door Stiffener 12"
1	MC_5412ESEL162008G	0	5412ESEL 16" x 20" Cover Gasket Part
1	MC_5412ESEL162008C-P	0	5412ESEL 16" x 20" Cover Part
2	STK-Q-07220	1	M6 Nylon Insert Lock Nut

Parts List

Tél: (450) 979-4373 Fax: (450) 979-4626 www.exmweb.com		Flatness Aplatissement Max 3.0mm Projection
Customer Client		Date
Drawn By Dessiné Par	BoxCad: BoxCad	Date 04-Feb-20
Material Matière	16 Ga H.R.P. & O. (1.4mm)	
Color Couleur	Asa-61 Grey	Finish Fini Smooth
Description	5412ESEL 16" x 20" Cover	
Part Number Numéro Pièce	5412ESEL162008C	Rev. 3
		0

This drawing is confidential and must not be reproduced or used without the consent of EXM

Ce dessin est confidentiel et ne doit pas être reproduit ou utilisé sans le consentement de EXM

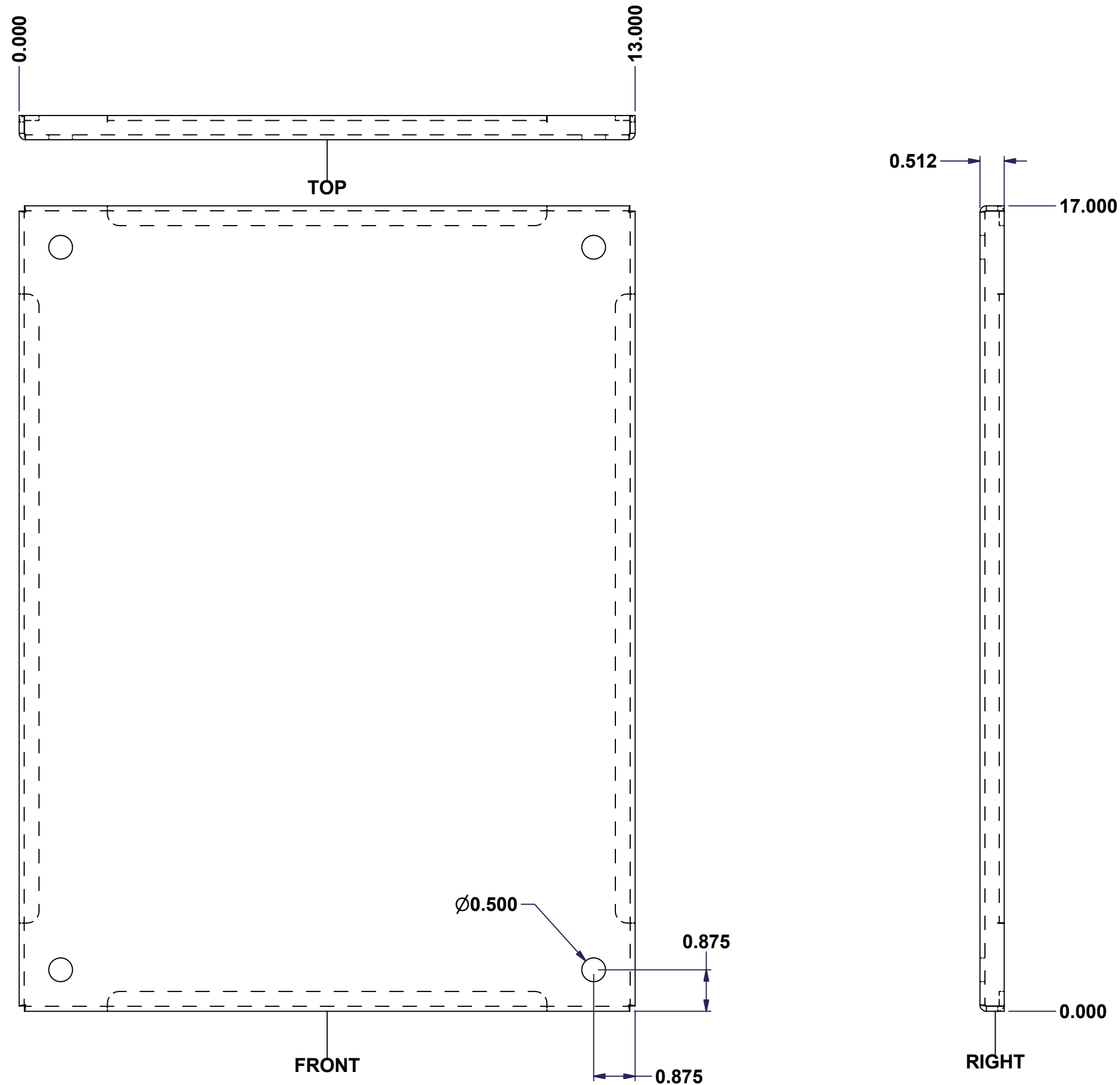

No.	Revisions	Date	By/Par

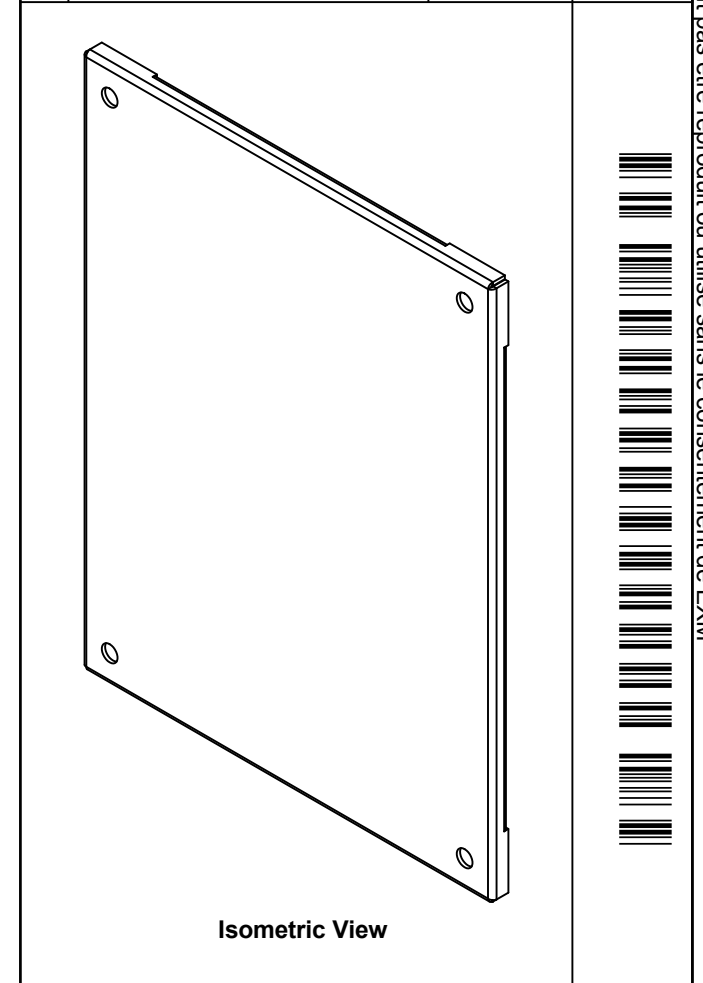

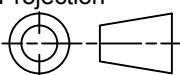
 Tél: (450) 979-4373 Fax: (450) 979-4626 www.exmweb.com		Flatness Aplatissement Max 3.0mm Projection 
Customer Client	Date	
Drawn By Dessiné Par	BoxCad: nickz	Date 01/03/2017
Material Matière	12 Ga Galvanized (2.5mm)	
Color Couleur	See Part List	Finish Fini See Part List
Description		Detail Rev.
885SP 20" x 16" Inner Panel Part		
Part Number Numéro Pièce	Rev.	1
885SP2016G	0	1

Qty	Part Number	Rev	Description	Material	Color	Finish
1	885SP2016G-P	0	885SP 20" x 16" Inner Panel Part	12 Ga Galvanized (2.5mm)	Unpainted	Galvanized

Parts List