

This drawing is confidential and must not be reproduced or used without the consent of EXM

Ce dessin est confidentiel et ne doit pas être reproduit ou utilisé sans le consentement de EXM

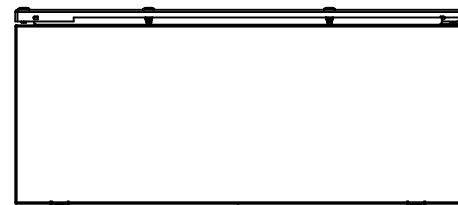

TOP

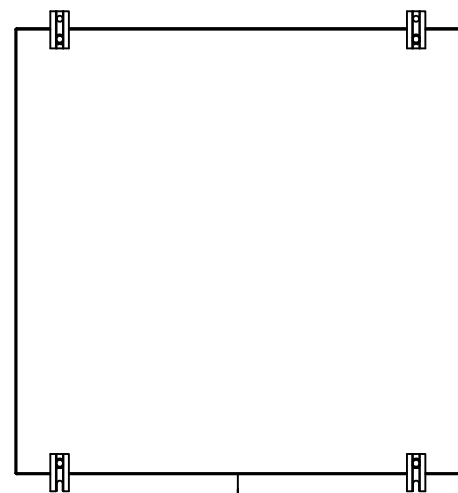

BACK



BOTTOM

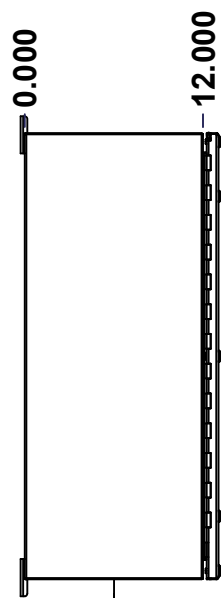

LEFT

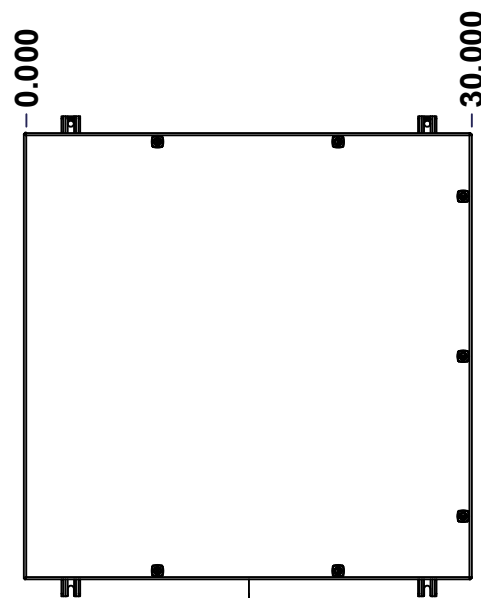

FRONT

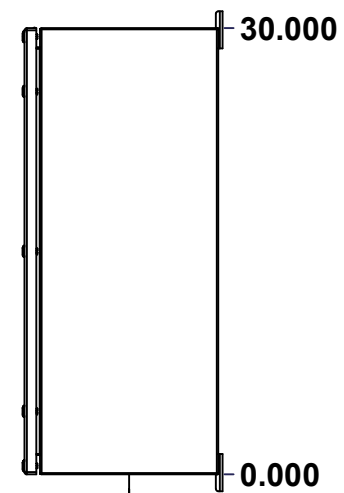

RIGHT

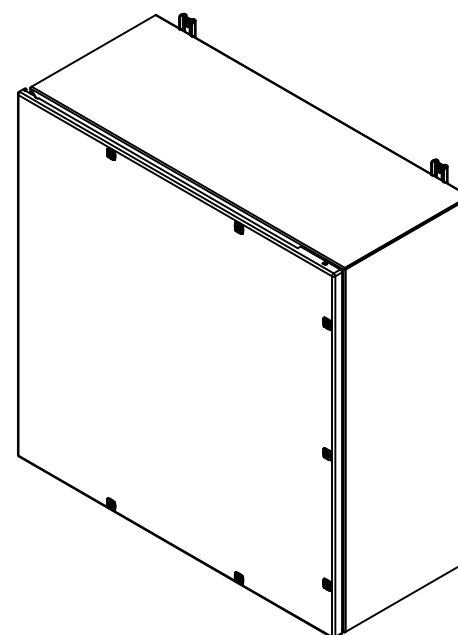

Isometric View

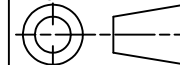

No.	Revisions	Date	By/Par

 Tél: (450) 979-4373 Fax: (450) 979-4626 www.exmweb.com		Flatness Aplatissement Max 3.0mm Projection 
Customer Client	Date	
Drawn By Dessiné Par	BoxCad: BoxCad	Date 19-Mar-20
Material Matière	14 Ga H.R.P. & O. (1.7mm)	
Color Couleur	Asa-61 Grey	Finish Fini Smooth
Description	Detail Rev.	
5412ESEL 30" x 30" x 12" Assembly		
Part Number Numéro Pièce	Rev.	1
5412ESEL303012	0	2

SEE BILL OF MATERIAL ON LAST PAGE

This drawing is confidential and must not be reproduced or used without the consent of EXM

Ce dessin est confidentiel et ne doit pas être reproduit ou utilisé sans le consentement de EXM

NOTE	
ITEM	DESCRIPTION
1	NEMA 4/12 Enclosure
2	C/W Standard ground studs on box and cover
3	W/O Standard door stiffener
4	C/W Standard inner panel (Sold separately)
5	C/W Standard inner panel mounting studs
6	C/W 885 ESMF1_OPEN Sold separately (Kit)
7	C/W 885 ESMF1_CLOSE Sold separately (Kit)

No.	Revisions	Date	By/Par

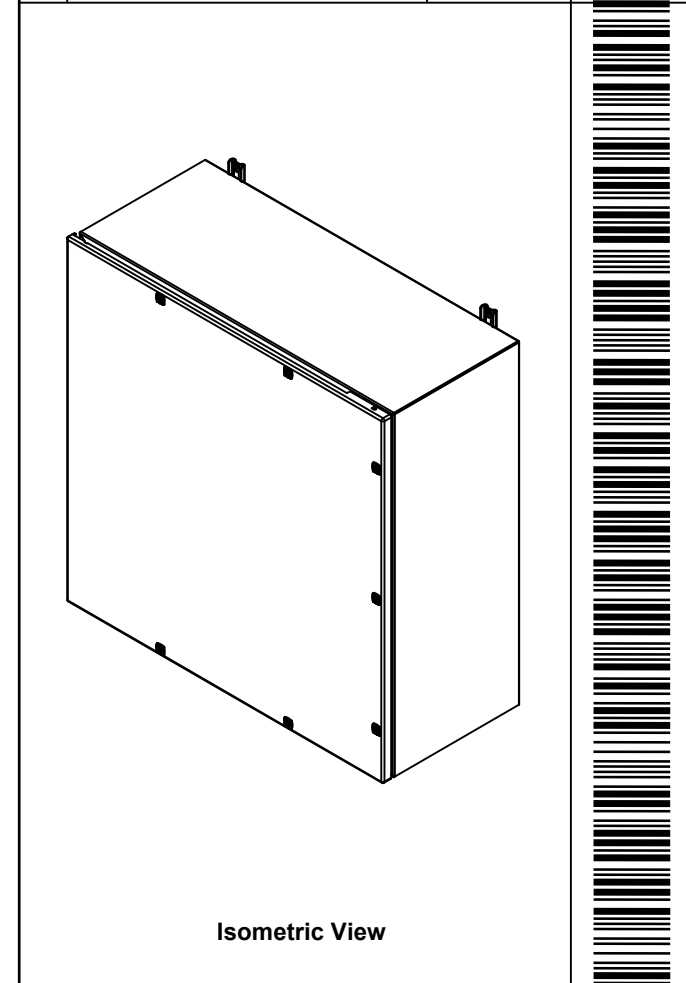

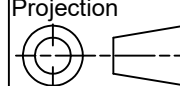
 Tél: (450) 979-4373 Fax: (450) 979-4626 www.exmweb.com		Flatness Aplatissement Max 3.0mm Projection 
Customer Client	Date	
Drawn By Dessiné Par	BoxCad: BoxCad	Date 19-Mar-20
Material Matière	14 Ga H.R.P. & O. (1.7mm)	
Color Couleur	Asa-61 Grey	Finish Fini Smooth
Description	Detail Rev.	
5412ESEL 30" x 30" x 12" Assembly		
Part Number Numéro Pièce	Rev.	2
5412ESEL303012	0	2

PACKING		
ITEM	QTY	DESCRIPTION
Cardboard sleeve	2	Top and Bottom
Cardboard strip	2	Between back of enclosure and inner panel
Plastic bag	1	To protect cover surface and inside gasket
Plastic strap - Black	2	To Squeeze the 2 cardboard sleeve together
Packaging label	1	White label with product number

Qty	Part Number	Rev	Description
1	880 PP	6	Self Adhesive Print Pocket
1	STK-K-01800	5	5412 ES Accessory Kit
1	885SP3030G	0	885SP 30" x 30" Inner Panel Part
1	MC_5412ESEL303012C	0	5412ESEL 30" x 30" Cover
4	STK-Q-07310	2	Flange Lock Nut M8
4	STK-Q-07610	8	M8 Plastic Spacer 22.2mm
1	MC_5412ESEL303012B	0	5412ESEL 30" x 30" x 12" Body
3	STK-Q-04050-10	8	M6 x 10mm Hexagon Socket Head Machine Screw with Nyseal
Parts List			

This drawing is confidential and must not be reproduced or used without the consent of EXM

Ce dessin est confidentiel et ne doit pas être reproduit ou utilisé sans le consentement de EXM

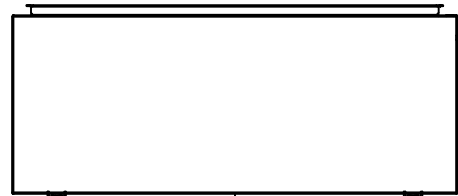

TOP

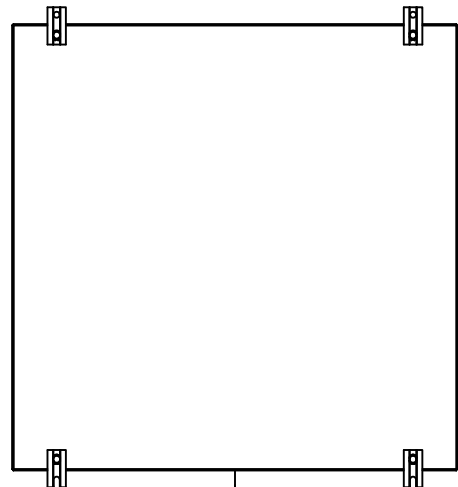

BACK

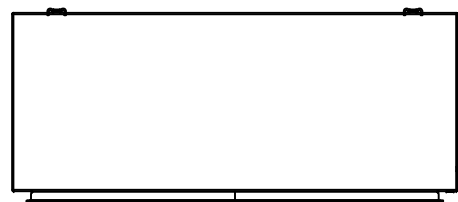

BOTTOM

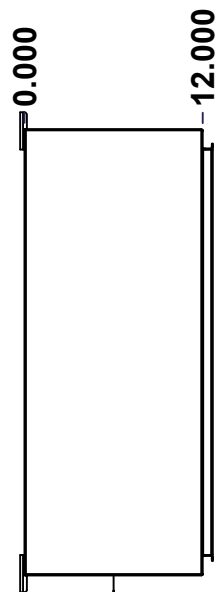

LEFT

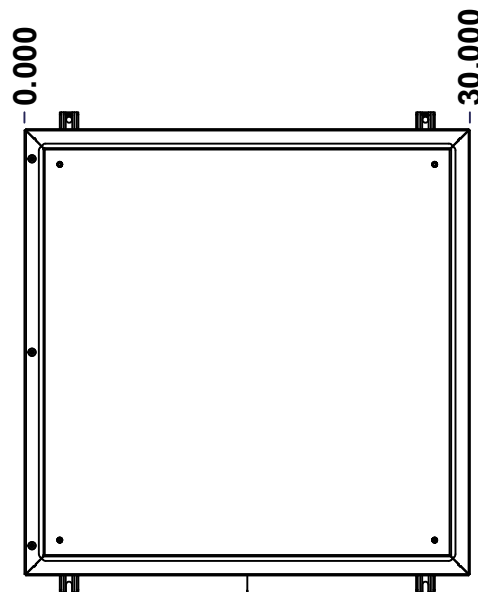

FRONT

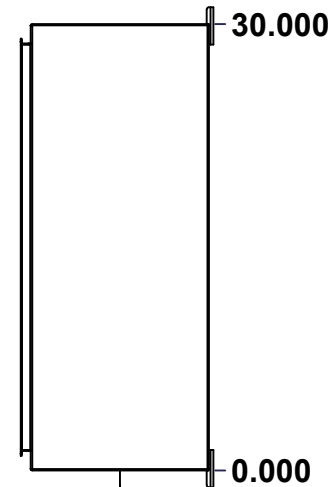

RIGHT

No.	Revisions	Date	By/Par

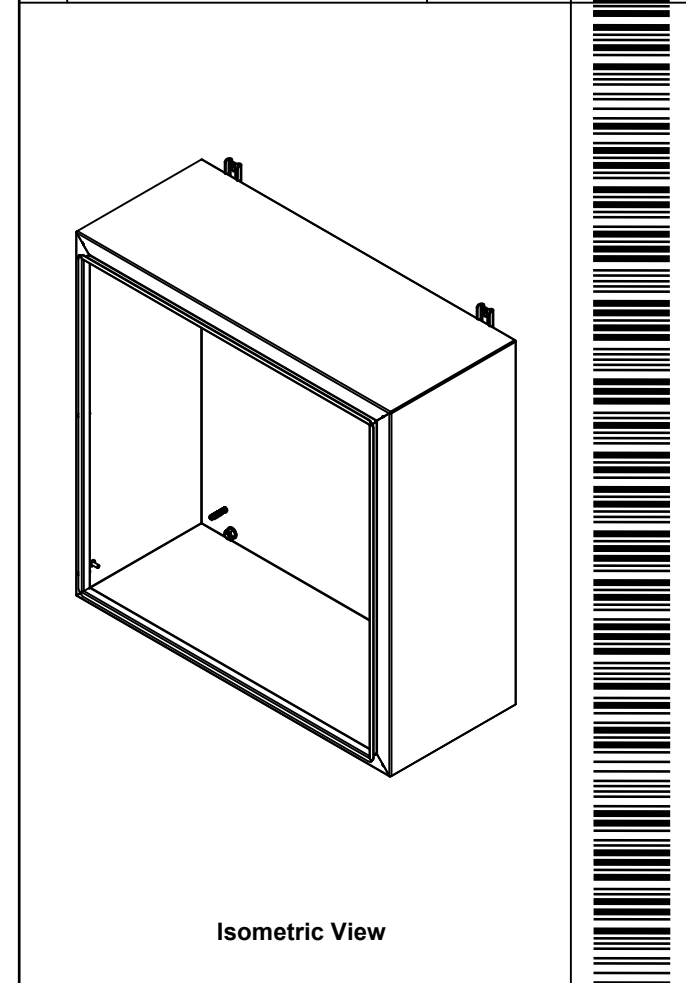

Isometric View



Tél: (450) 979-4373
 Fax: (450) 979-4626
www.exmweb.com

Flatness
Aplatissement
Max 3.0mm
Projection

Customer Client	Date
Drawn By / Dessiné Par: BoxCad: BoxCad	Date: 19-Mar-20
Material / Matière: 14 Ga H.R.P. & O. (1.7mm)	
Color / Couleur: Asa-61 Grey	Finish / Fini: Smooth
Description: 5412ESEL 30" x 30" x 12" Body	
Part Number / Numéro Pièce: 5412ESEL303012B	Detail Rev.:
Rev. 0	1 / 7

SEE BILL OF MATERIAL ON LAST PAGE

This drawing is confidential and must not be reproduced or used without the consent of EXM

Ce dessin est confidentiel et ne doit pas être reproduit ou utilisé sans le consentement de EXM

STANDARD FEATURES ARE NOT LISTED IN THIS HOLE TABLE

HOLE TABLE - LEFT VIEW (CUSTOM FEATURE ONLY)

CUT-OUT	XDIM	YDIM	DESCRIPTION
1	10.500	2.000	GND STUD M6 x 16mm (Inside)

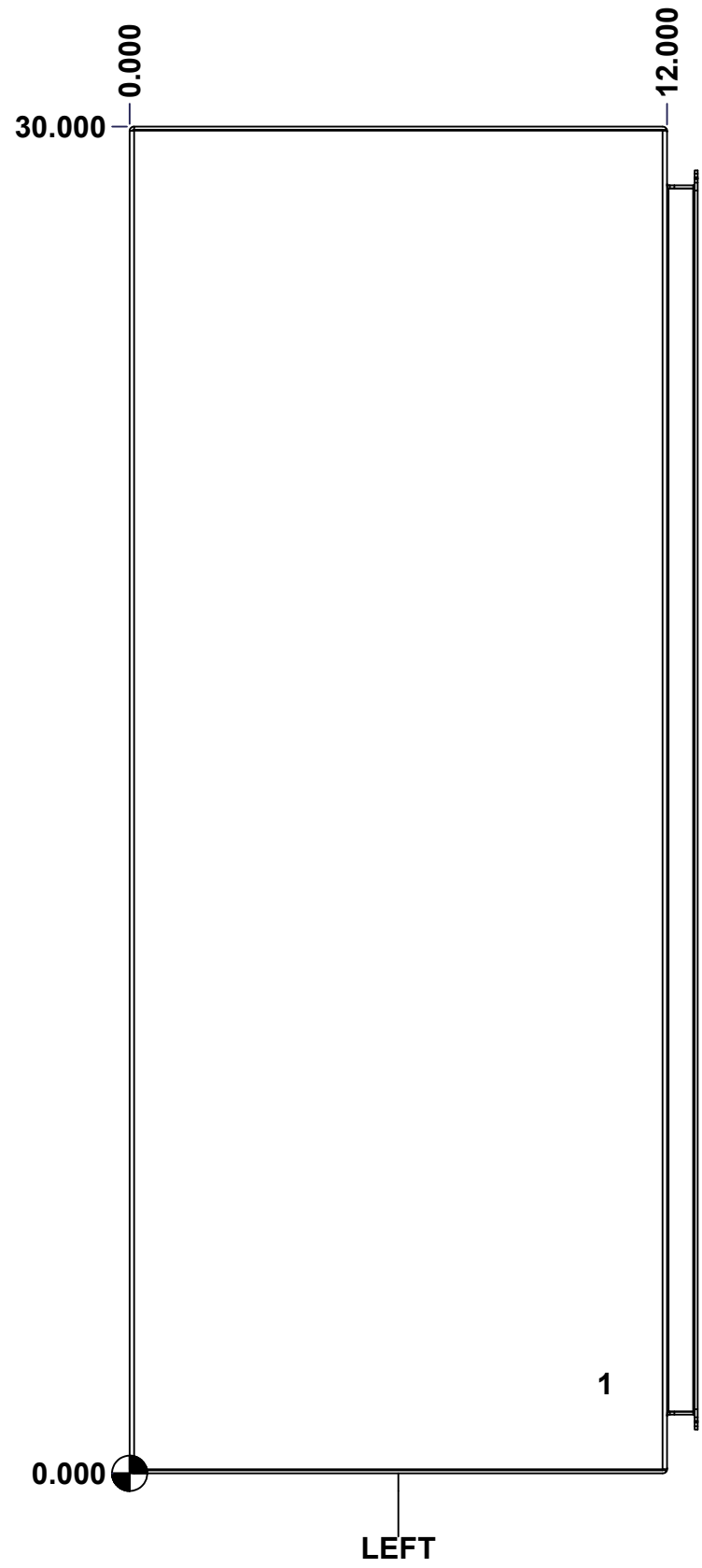

	Description		Status	
	5412ESEL 30" x 30" x 12" Body			
Part Number Numéro Pièce		Rev.	5 / 7	
5412ESEL303012B		0		

This drawing is confidential and must not be reproduced or used without the consent of EXM

Ce dessin est confidentiel et ne doit pas être reproduit ou utilisé sans le consentement de EXM

STANDARD FEATURES ARE NOT LISTED IN THIS HOLE TABLE

HOLE TABLE - BACK VIEW (CUSTOM FEATURE ONLY)

CUT-OUT	XDIM	YDIM	DESCRIPTION
1	2.375	2.375	IP STUD M8 x 35mm (Inside)
2	2.375	27.625	IP STUD M8 x 35mm (Inside)
3	27.625	27.625	IP STUD M8 x 35mm (Inside)
4	27.625	2.375	IP STUD M8 x 35mm (Inside)

5	27.000	0.000	FOOT 885 ESMF1_OPEN
6	3.000	0.000	FOOT 885 ESMF1_OPEN
7	27.000	30.000	FOOT 885 ESMF1_CLOSE
8	3.000	30.000	FOOT 885 ESMF1_CLOSE

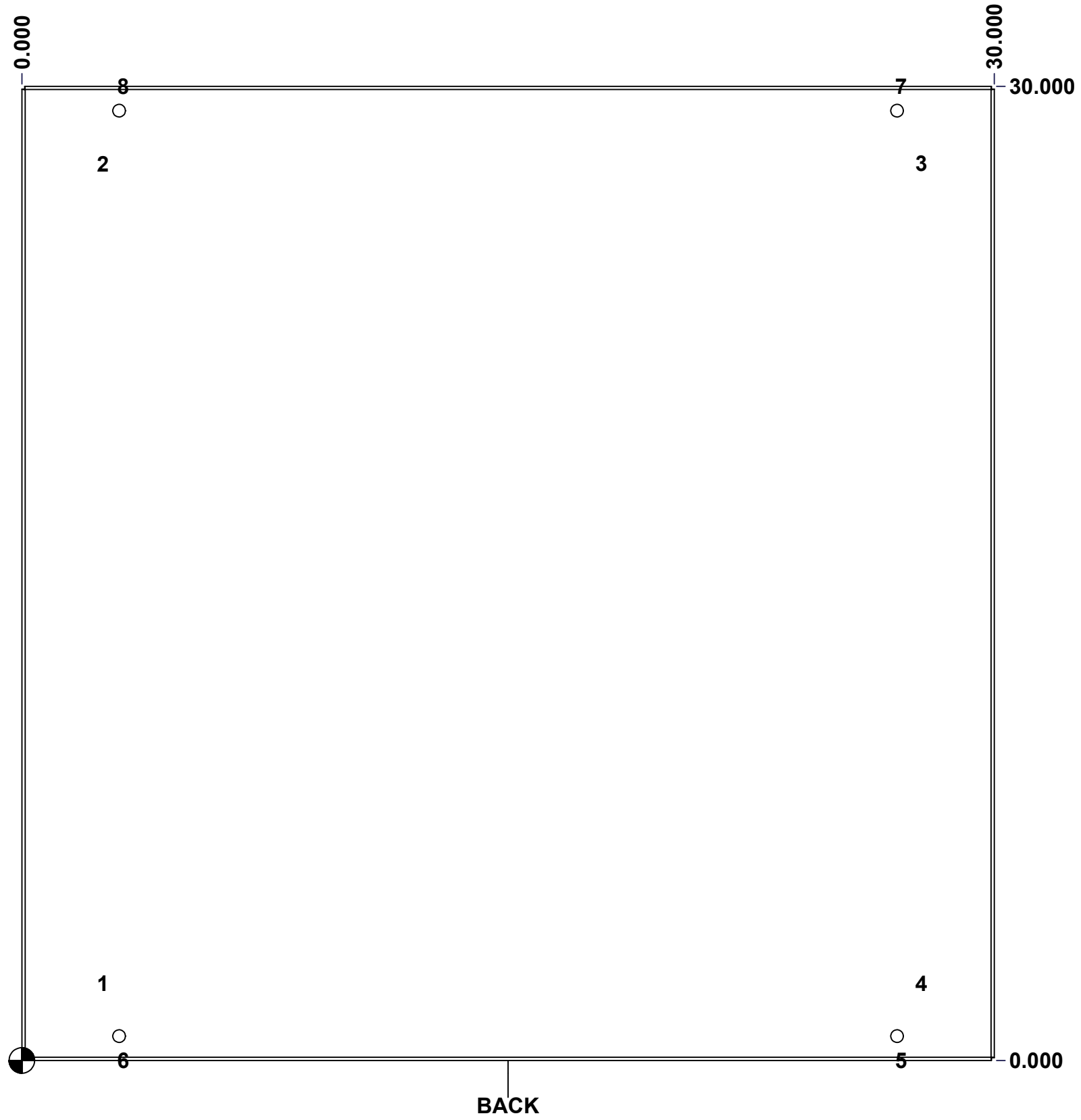

	Description		Status	
	5412ESEL 30" x 30" x 12" Body			
Part Number Numéro Pièce		Rev.	6	
5412ESEL303012B		0	7	

This drawing is confidential and must not be reproduced or used without the consent of EXM

Ce dessin est confidentiel et ne doit pas être reproduit ou utilisé sans le consentement de EXM

No.	Revisions	Date	By/Par

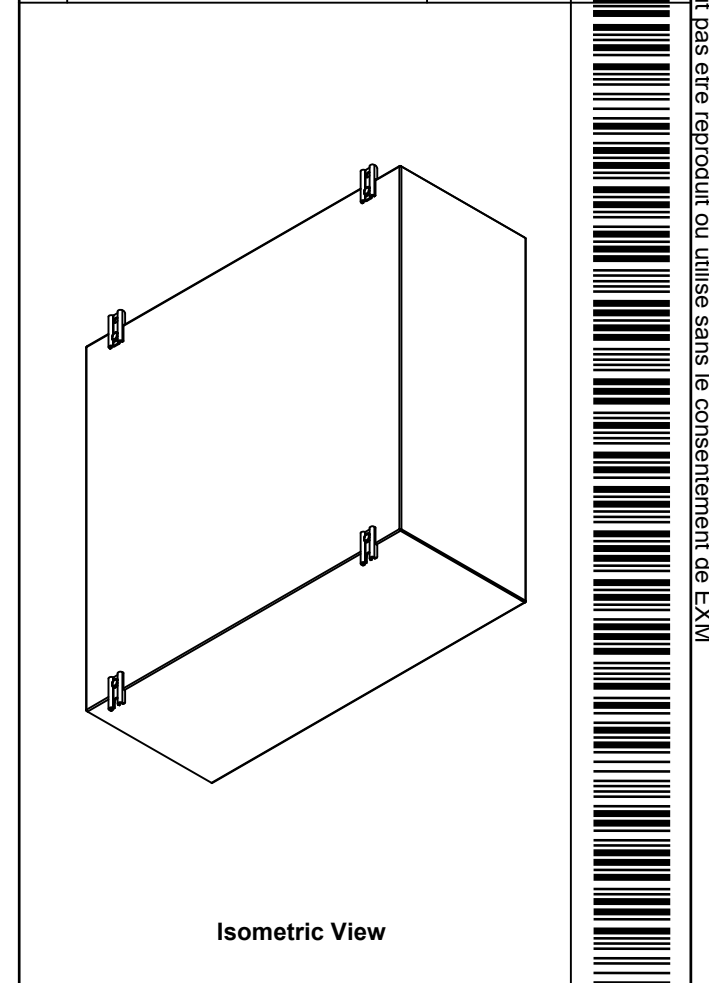

Qty	Part Number	Rev	Description
1	STK-Q-16080	0	Ground Stud M6 x 16mm
3	RIVET_NUT_SS_M6_FH_CE	0	Stainless Steel Rivet Nut M6 (Low Profile Close End)
1	STK-P-02400S	0	Powder Paint (Asa-61 Grey / Smooth)
4	STK-Q-16005	1	Stud M8 x 35 (No Paint Cap Required)
1	MC_5412ESEL303012B-P	0	5412ESEL 30" x 30" x 12" Body Part
2	885 ESMF1_CLOSE	0	885 ESMF1 Mounting Foot (Closed Hole)
2	885 ESMF1_OPEN	0	885 ESMF1 Mounting Foot (Opened Hole)
Parts List			

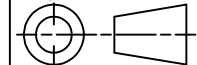
 Tél: (450) 979-4373 Fax: (450) 979-4626 www.exmweb.com		Flatness Aplatissement Max 3.0mm
Customer Client		Projection 
Drawn By Dessiné Par BoxCad: BoxCad		Date 19-Mar-20
Material Matière 14 Ga H.R.P. & O. (1.7mm)		
Color Couleur Asa-61 Grey	Finish Fini Smooth	
Description 5412ESEL 30" x 30" x 12" Body		Detail Rev.
Part Number Numéro Pièce 5412ESEL303012B		Rev. 7 0

This drawing is confidential and must not be reproduced or used without the consent of EXM

Ce dessin est confidentiel et ne doit pas être reproduit ou utilisé sans le consentement de EXM

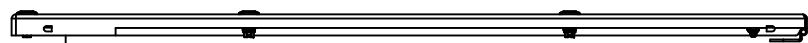

TOP

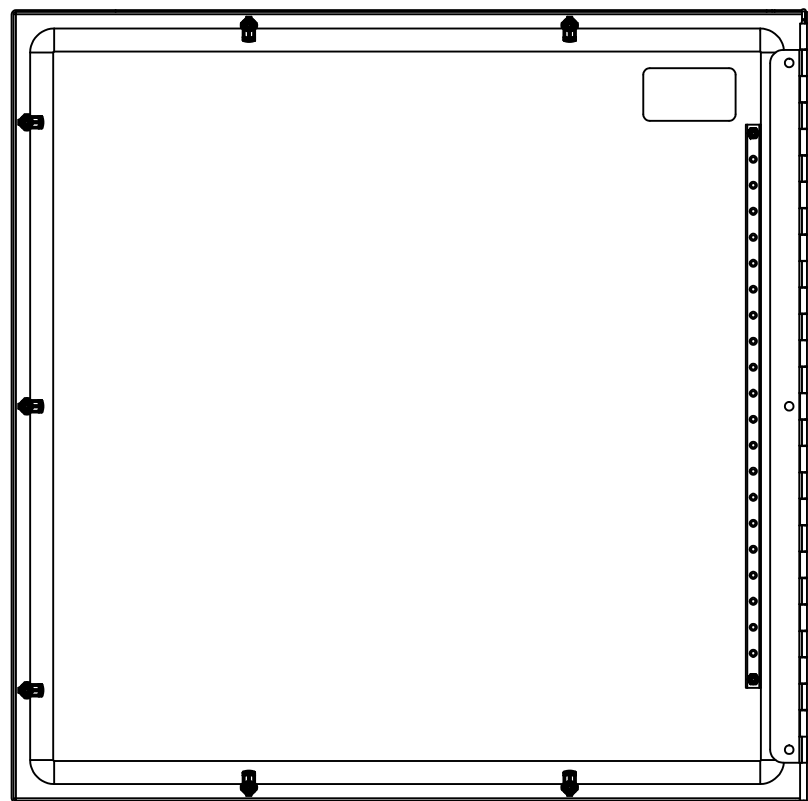

BACK

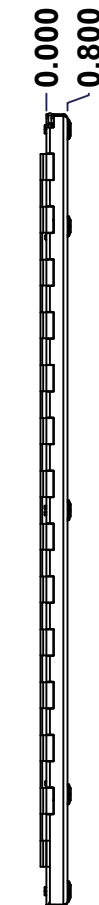

LEFT

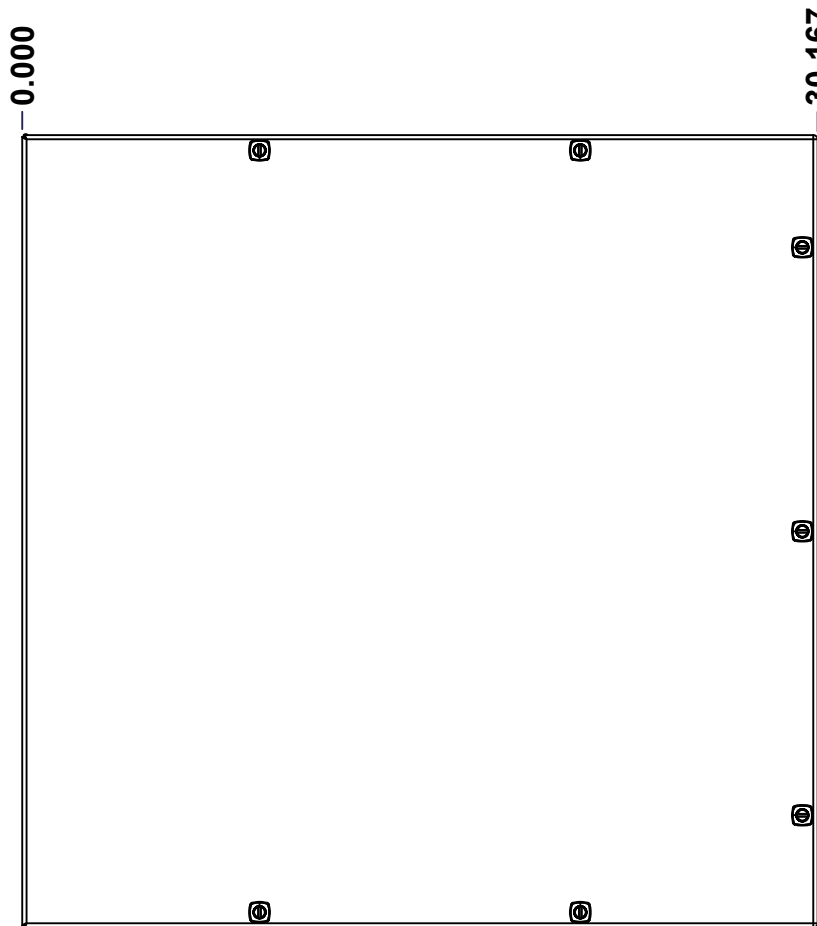

FRONT

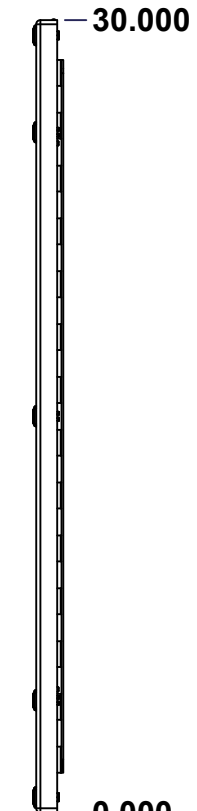

RIGHT

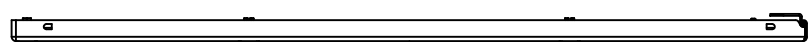

BOTTOM

No.	Revisions	Date	By/Par

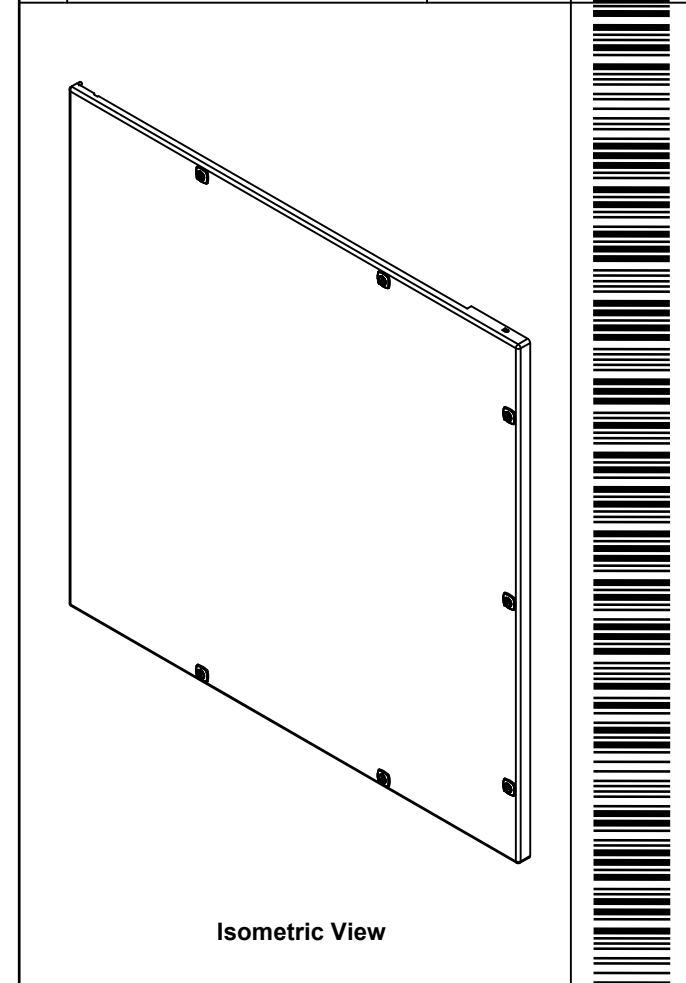

Isometric View

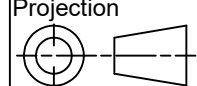

 Tél: (450) 979-4373 Fax: (450) 979-4626 www.exmweb.com		Flatness Aplatissement Max 3.0mm Projection 
Customer Client	Date	
Drawn By / Dessiné Par: BoxCad: BoxCad	Date: 19-Mar-20	
Material / Matière: 14 Ga H.R.P. & O. (1.7mm)		
Color / Couleur: Asa-61 Grey	Finish / Fini: Smooth	
Description: 5412ESEL 30" x 30" Cover		Detail Rev.
Part Number / Numéro Pièce: 5412ESEL303012C	Rev. 0	1 / 3

SEE BILL OF MATERIAL ON LAST PAGE

This drawing is confidential and must not be reproduced or used without the consent of EXM

Ce dessin est confidentiel et ne doit pas être reproduit ou utilisé sans le consentement de EXM

STANDARD FEATURES ARE NOT LISTED IN THIS HOLE TABLE

HOLE TABLE - FRONT VIEW (CUSTOM FEATURE ONLY)

CUT-OUT	XDIM	YDIM	DESCRIPTION
1	2.122	4.665	STUD M6 x 18mm (Inside)
2	2.122	25.335	STUD M6 x 18mm (Inside)

3	4.458	26.803	LABEL_EXM (Inside)
4	29.587	25.750	LOCK 880 SCQ5-SL @ 180.0°
5	29.587	15.000	LOCK 880 SCQ5-SL @ 180.0°
6	29.587	4.250	LOCK 880 SCQ5-SL @ 180.0°
7	9.000	29.420	LOCK 880 SCQ5-SL @ 270.0°
8	21.167	29.420	LOCK 880 SCQ5-SL @ 270.0°
9	9.000	0.580	LOCK 880 SCQ5-SL @ 90.0°
10	21.167	0.580	LOCK 880 SCQ5-SL @ 90.0°

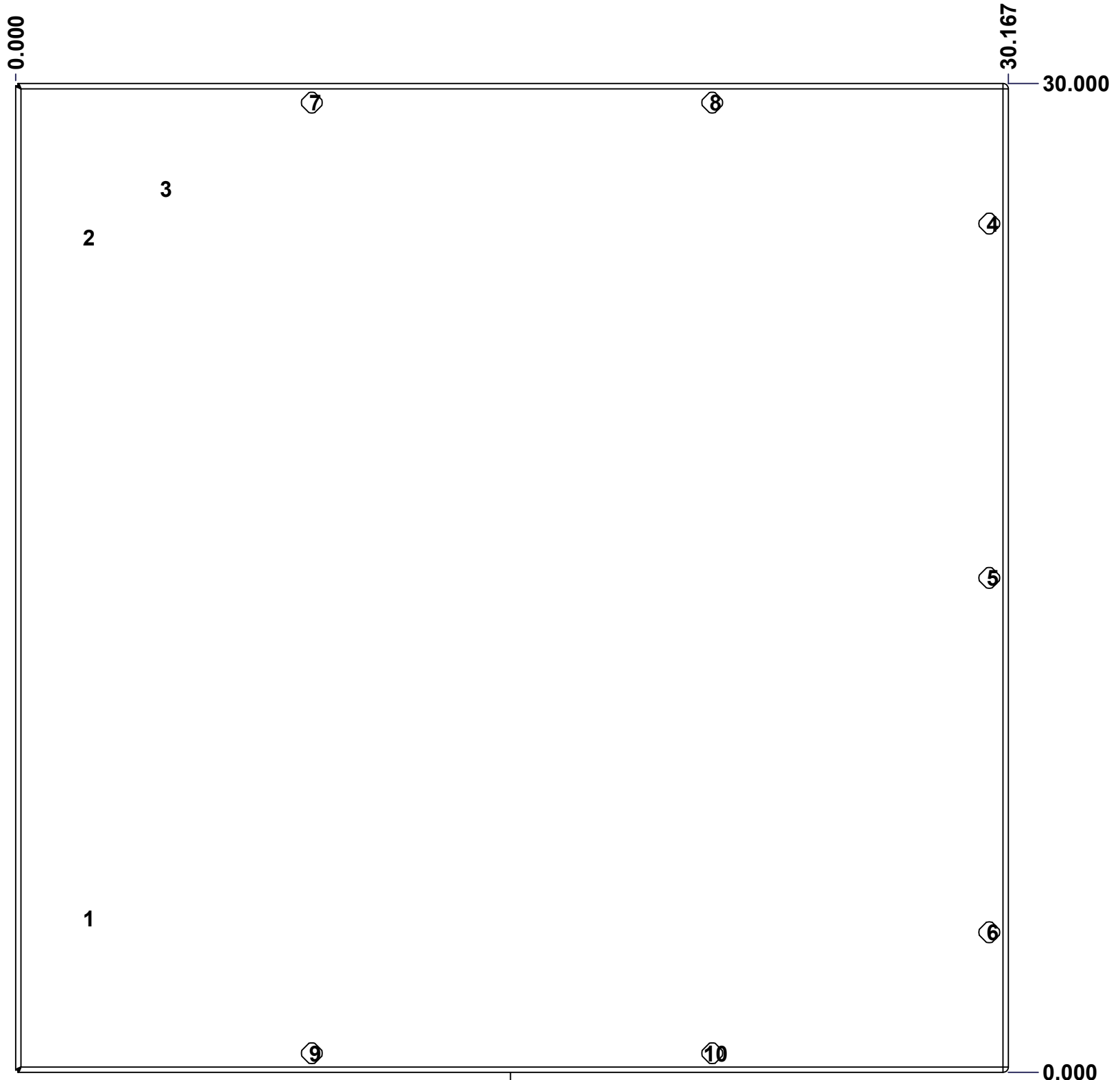

FRONT

	Description	Status	
	5412ESEL 30" x 30" Cover	(NULL)	
	Part Number Numéro Pièce	Rev.	
	5412ESEL303012C	0	2 / 3

This drawing is confidential and must not be reproduced or used without the consent of EXM

Ce dessin est confidentiel et ne doit pas être reproduit ou utilisé sans le consentement de EXM

No.	Revisions	Date	By/Par

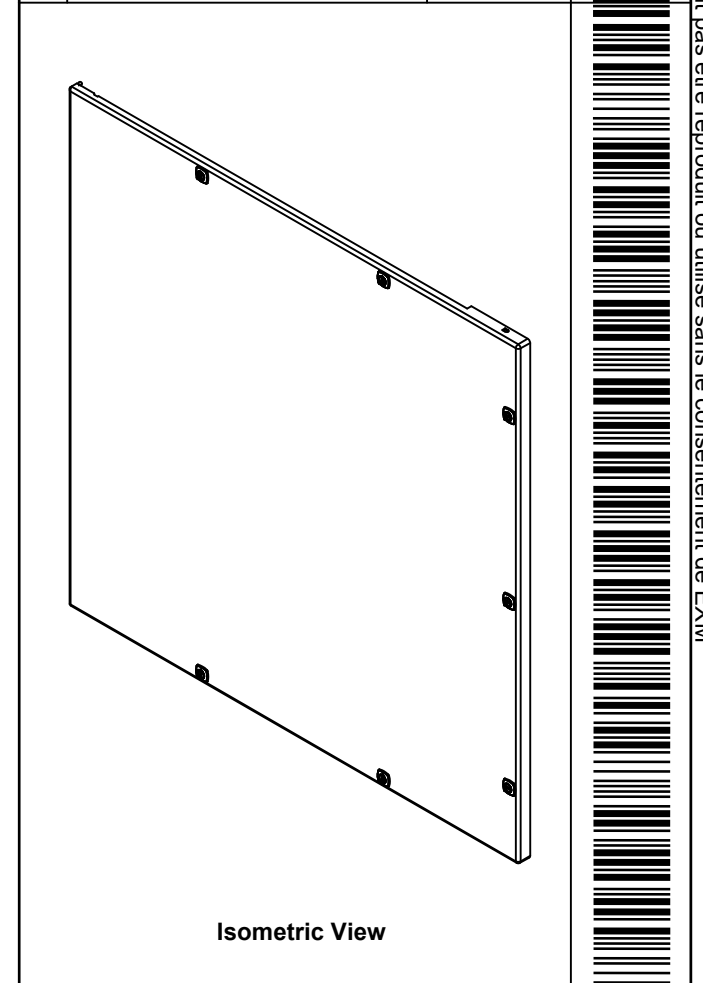

Qty	Part Name	Rev	Description
1	STK-S-00100	0	3.5" x 2" Silver Milar Flexcon Sticker
1	STK-P-02400S	0	Powder Paint (Asa-61 Grey / Smooth)
2	STK-Q-16055	1	M6 x 18mm Stud (No Paint Cap Required)
7	STK-A-79955	2	5412 ESEL Plastic Clip-in 1/4 Turn Lock
1	MC_5412ESEL303012HP-P	0	5412ESEL 30" x 30" Cover Part
1	MC_5412ESEL303012H-P	0	5412ESEL 30" x 30" Cover Part
1	STK-Q-46020-24	5	5412 ES Vertical Door Stiffener 24"
1	MC_5412ESEL303012G	0	5412ESEL 30" x 30" Cover Gasket Part
1	MC_5412ESEL303012C-P	0	5412ESEL 30" x 30" Cover Part
2	STK-Q-07220	1	M6 Nylon Insert Lock Nut
Parts List			

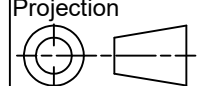
 Tél: (450) 979-4373 Fax: (450) 979-4626 www.exmweb.com		Flatness Aplatissement Max 3.0mm Projection 
Customer Client	Date	
Drawn By Dessiné Par	BoxCad: BoxCad	Date 19-Mar-20
Material Matière	14 Ga H.R.P. & O. (1.7mm)	
Color Couleur	Asa-61 Grey	Finish Fini Smooth
Description		Detail Rev.
5412ESEL 30" x 30" Cover		
Part Number Numéro Pièce	Rev. 3	3
5412ESEL303012C	0	

This drawing is confidential and must not be reproduced or used without the consent of EXM

Ce dessin est confidentiel et ne doit pas être reproduit ou utilisé sans le consentement de EXM

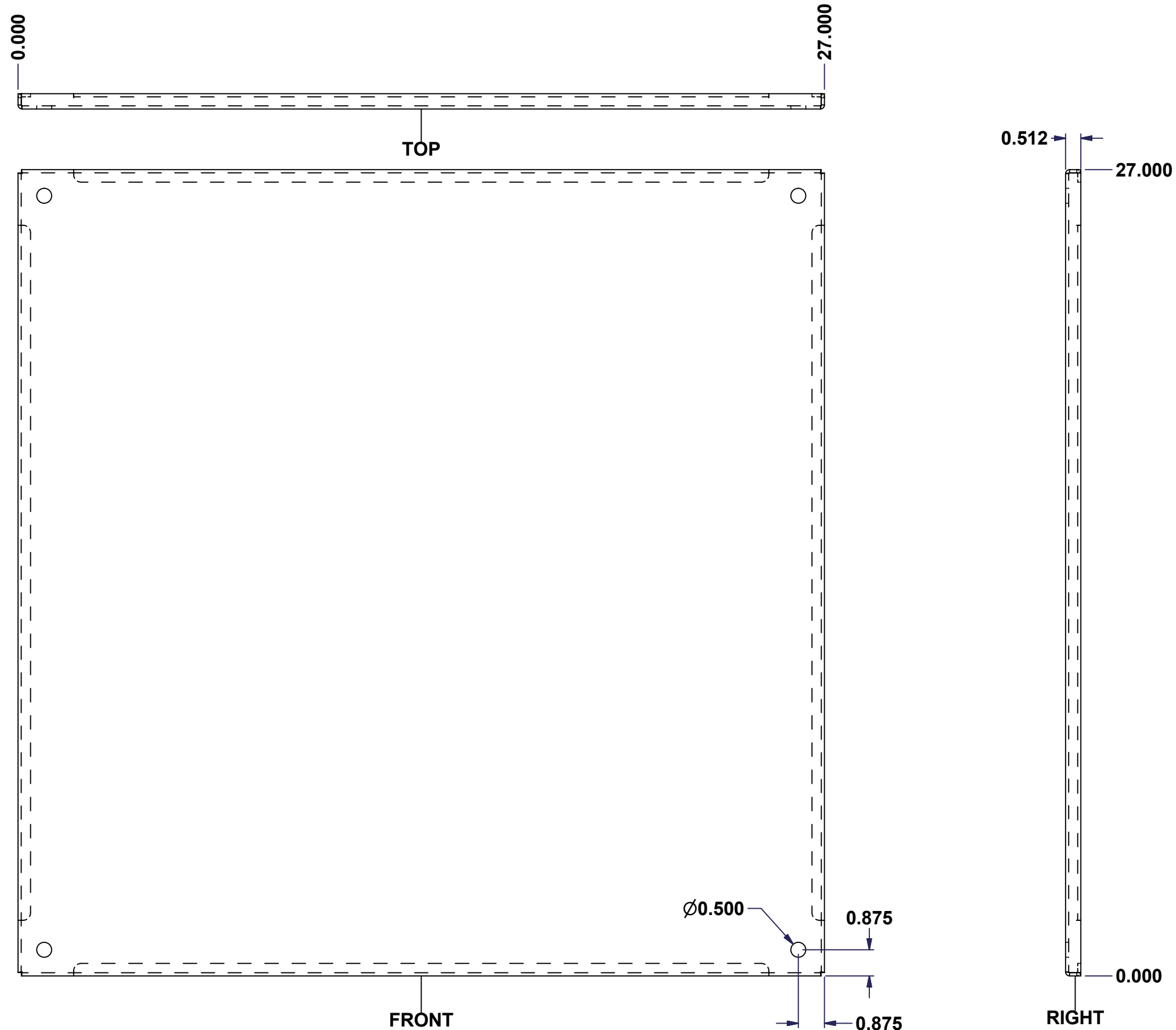

No.	Revisions	Date	By/Par

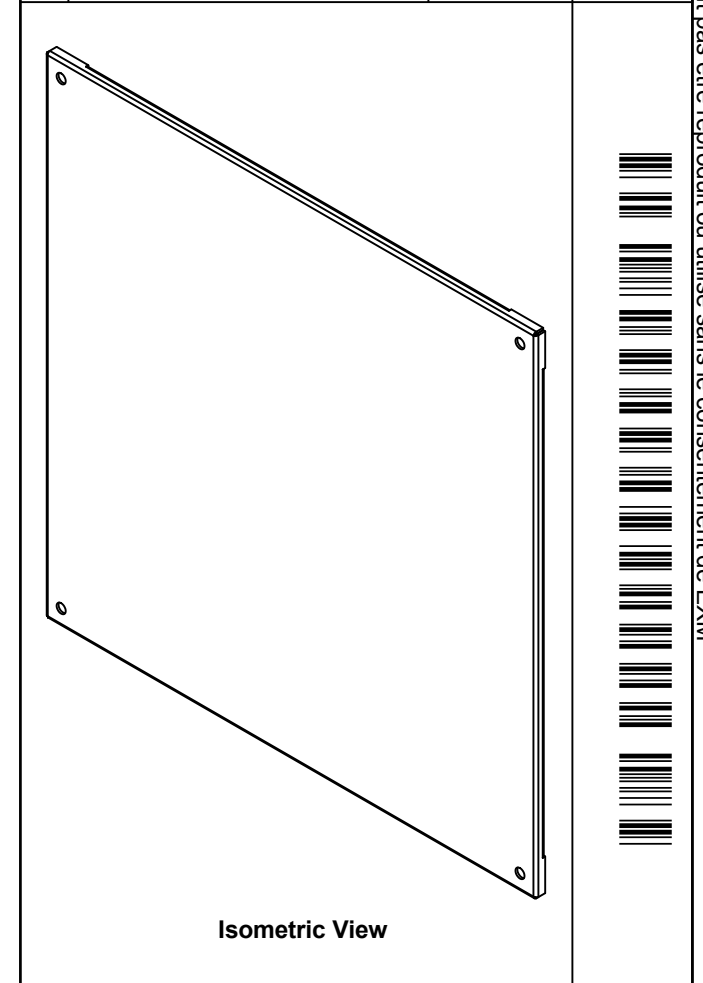

Tél: (450) 979-4373 Fax: (450) 979-4626 www.exmweb.com	Flatness Aplatissement Max 3.0mm
	Projection
Customer Client	Date
Drawn By / Dessiné Par: BoxCad: nickz	Date: 01/03/2017
Material / Matière: 12 Ga Galvanized (2.5mm)	
Color / Couleur: See Part List	Finish / Fini: See Part List
Description: 885SP 30" x 30" Inner Panel Part	
Part Number / Numéro Pièce: 885SP3030G	Detail Rev. / Rev.: 0

Qty	Part Number	Rev	Description	Material	Color	Finish
1	885SP3030G-P	0	885SP 30" x 30" Inner Panel Part	12 Ga Galvanized (2.5mm)	Unpainted	Galvanized

Parts List

1
1