

This drawing is confidential and must not be reproduced or used without the consent of EXM

Ce dessin est confidentiel et ne doit pas être reproduit ou utilisé sans le consentement de EXM

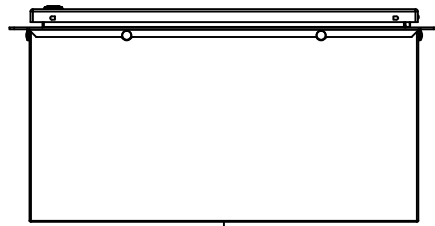

TOP

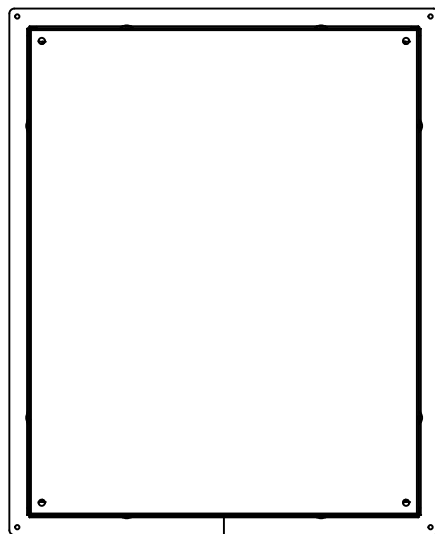

BACK

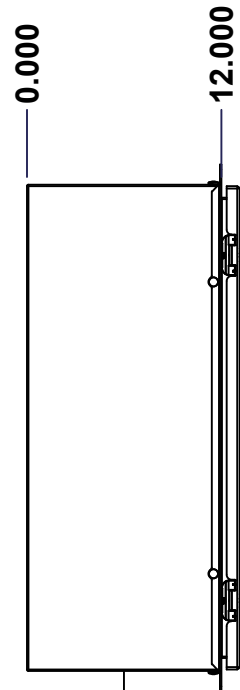

LEFT

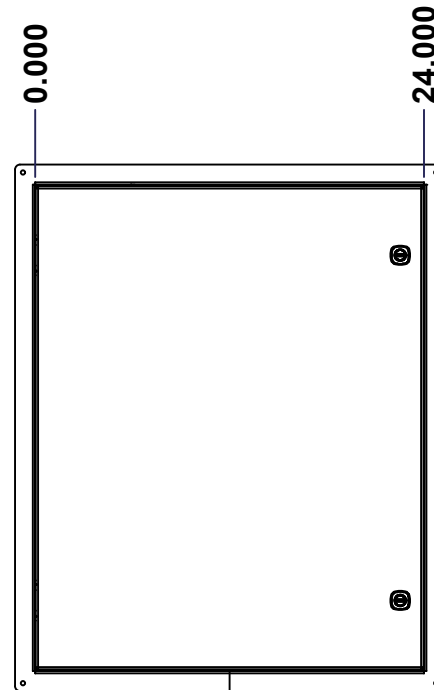

FRONT

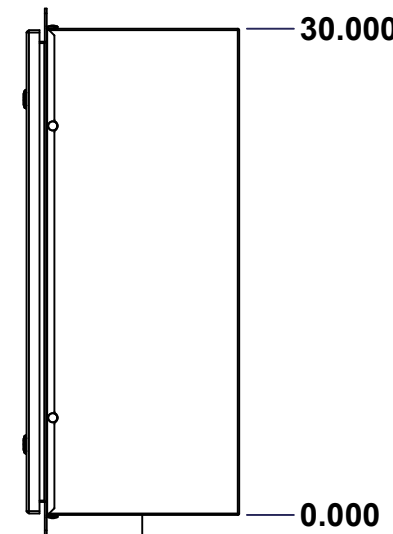

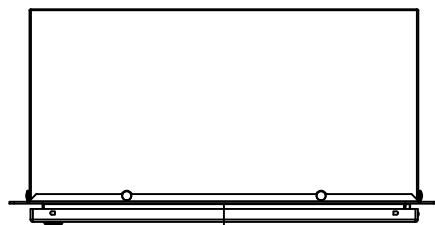

RIGHT

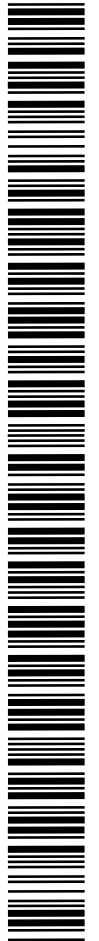
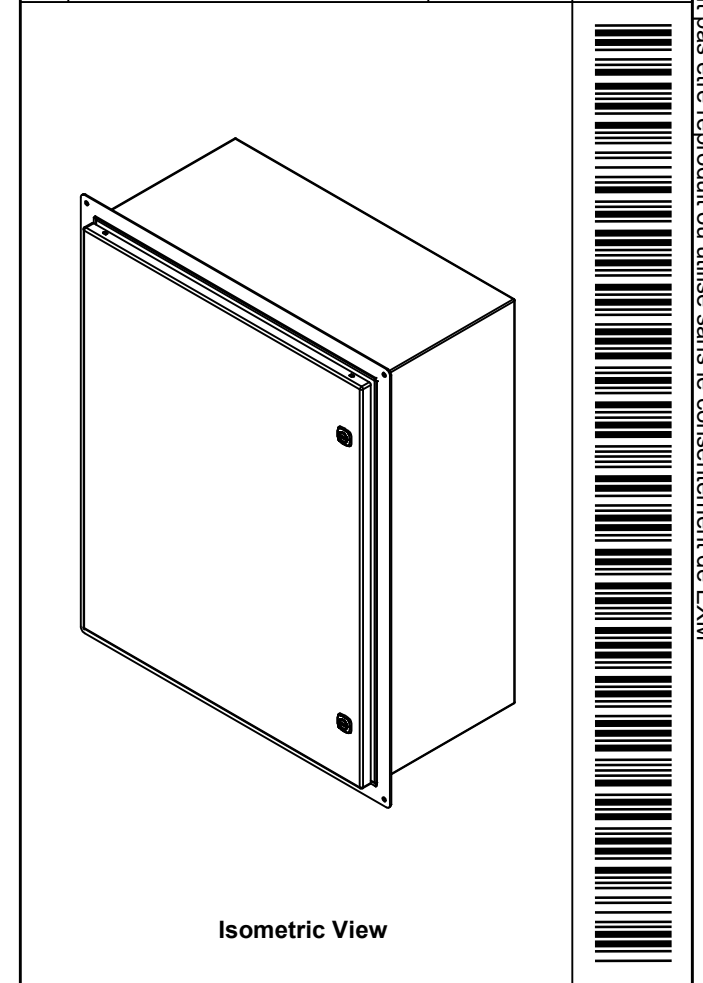

BOTTOM

| No. | Revisions | Date | By/Par |
|-----|-----------|------|--------|
| | | | |
| | | | |
| | | | |
| | | | |



| | | | |
|--|--|---------------------------|-------------|
|  Tél: (450) 979-4373 Fax: (450) 979-4626 www.exmweb.com | | Flatness Aplatissement | |
| | | Max 3.0mm | |
| Customer Client | | Date | |
| Drawn By Dessiné Par BoxCad: BoxCad | | Date 23-Dec-24 | |
| Material Matière 16 Ga Cold Rolled A1008 CS Type B (1.4mm) | | | |
| Color Couleur Asa-61 Grey | | Finish Fini Smooth | |
| Description 5412ESFM 30" x 24" x 12" Assembly | | | Detail Rev. |
| Part Number Numéro Pièce 5412ESFM302412TH | | Rev. 0 | 1 19 |

SEE BILL OF MATERIAL ON LAST PAGE

This drawing is confidential and must not be reproduced or used without the consent of EXM

Ce dessin est confidentiel et ne doit pas être reproduit ou utilisé sans le consentement de EXM

| NOTE | |
|------|--|
| ITEM | DESCRIPTION |
| 1 | NEMA 4, 12 Enclosure (IP66) |
| 2 | C/W Standard ground studs on box and cover |
| 3 | C/W Standard door stiffener |
| 4 | C/W Standard inner panel (Included) |
| 5 | C/W Standard inner panel mounting studs |
| 6 | C/W R5 Insulation (Installed aluminum visible) |

| No. | Revisions | Date | By/Par |
|-----|-----------|------|--------|
| | | | |
| | | | |
| | | | |
| | | | |
| | | | |
| | | | |

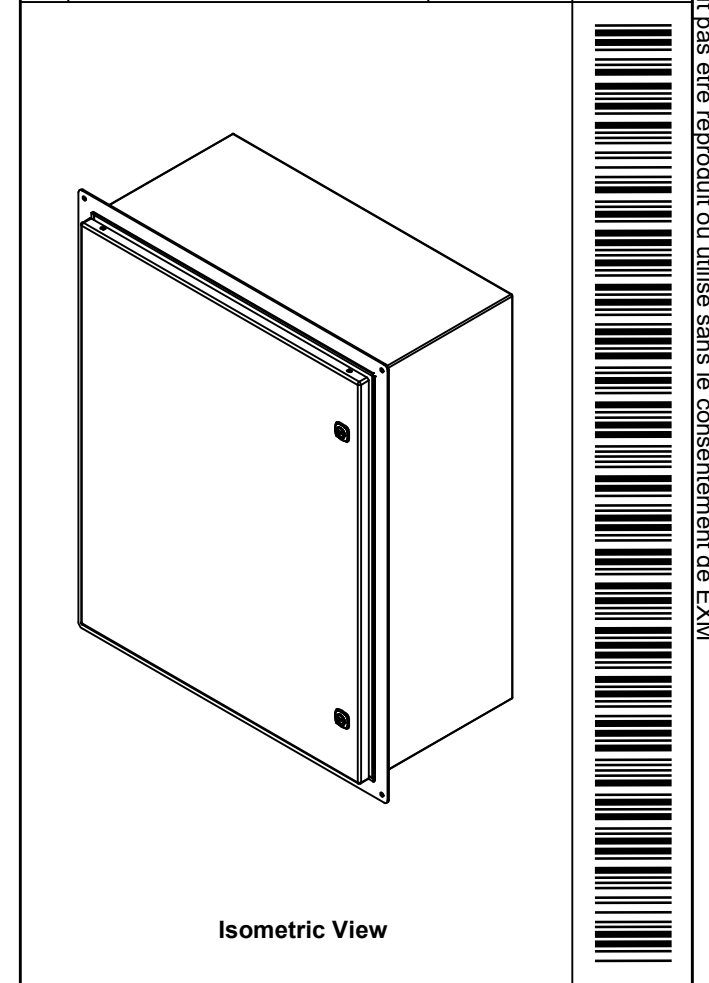

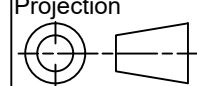
| | |
|--|---|
|  Tél: (450) 979-4373 Fax: (450) 979-4626 www.exmweb.com | Flatness Aplatissement |
| | Max 3.0mm |
| Projection |  |
| Customer Client | Date |
| Drawn By Dessiné Par BoxCad: BoxCad | Date 23-Dec-24 |
| Material Matière 16 Ga Cold Rolled A1008 CS Type B (1.4mm) | |

| PACKING | | |
|-----------------------|-----|--|
| ITEM | QTY | DESCRIPTION |
| Cardboard sleeve | 2 | Top and Bottom |
| Cardboard strip | 2 | Between back of enclosure and inner panel |
| Plastic bag | 1 | To protect cover surface and inside gasket |
| Plastic strap - Black | 2 | To Squeeze the 2 cardboard sleeve together |
| Packaging label | 1 | White label with product number |

| | | | |
|------------|-------------------|-----|--|
| 4 | STK-Q-00600 | 2 | M12 to M8 Adaptor |
| 1 | 881 SP3024G | 0 | 881 SP - Inner Panel |
| 1 | STK-K-01800 | 5 | 5412 ES Accessory Kit |
| 1 | 5412ESFM302412THC | 0 | 5412ESFM 30" x 24" Cover |
| 1 | 5412ESFM302412THB | 0 | 5412ESFM 30" x 24" x 12" Body |
| 2 | STK-Q-04050-08 | 0 | M6 x 8mm Hexagon Socket Head Machine Screw |
| Qty | Part Number | Rev | Description |
| Parts List | | | |

| | | | |
|-----------------------------|-----------------------------------|----------------|--------|
| Color Couleur | Asa-61 Grey | Finish Fini | Smooth |
| Description | 5412ESFM 30" x 24" x 12" Assembly | | |
| Part Number Numéro Pièce | 5412ESFM302412TH | | Rev. 2 |
| | | | 0 |
| | | | 19 |

This drawing is confidential and must not be reproduced or used without the consent of EXM

Ce dessin est confidentiel et ne doit pas être reproduit ou utilisé sans le consentement de EXM

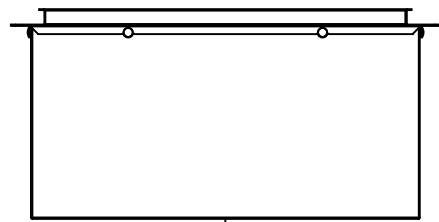

TOP

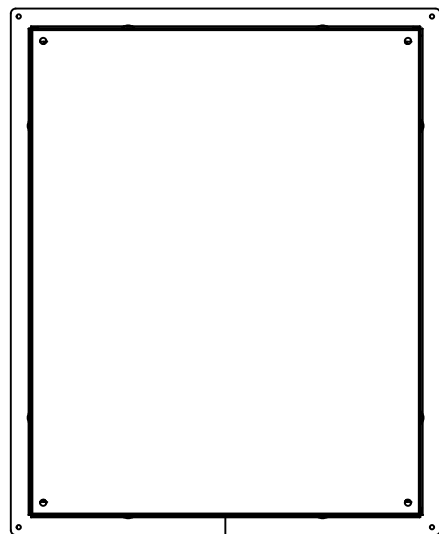

BACK

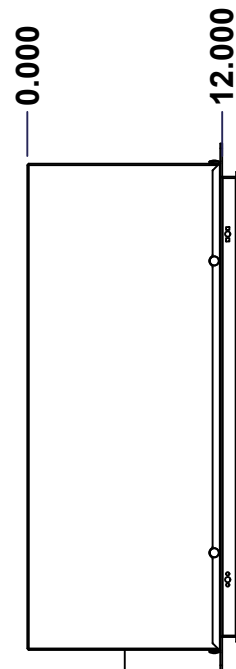

LEFT

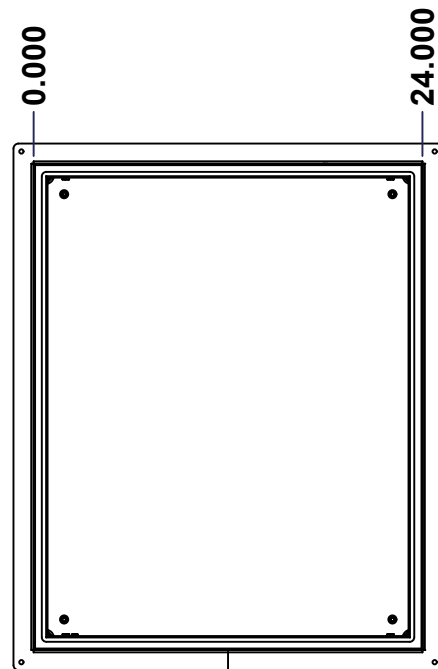

FRONT

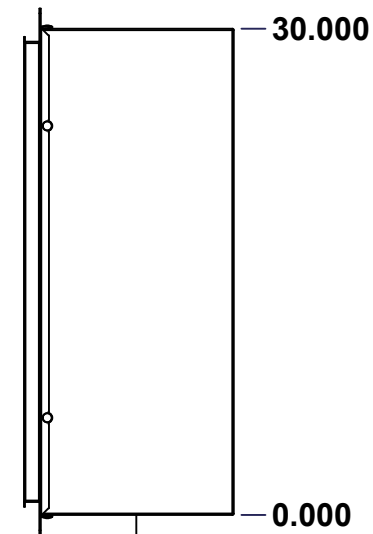

RIGHT

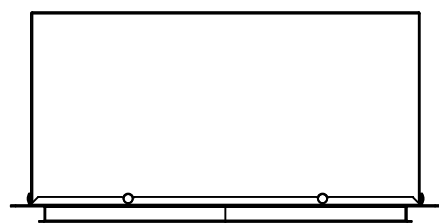

BOTTOM

| No. | Revisions | Date | By/Par |
|-----|-----------|------|--------|
| | | | |
| | | | |
| | | | |
| | | | |

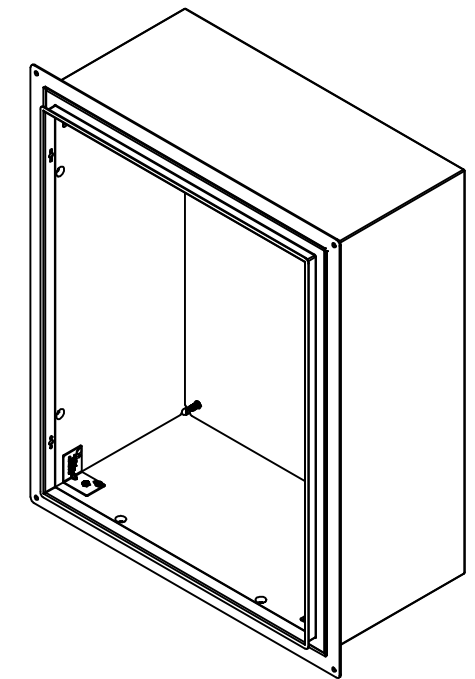

Isometric View



Tél: (450) 979-4373
 Fax: (450) 979-4626
www.exmweb.com

Flatness
Aplatissement

Max 3.0mm

Projection

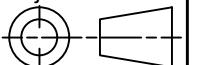

| | |
|---|-----------------------|
| Customer Client | Date |
| Drawn By / Dessiné Par: BoxCad: BoxCad | Date: 23-Dec-24 |
| Material / Matière: 16 Ga Cold Rolled A1008 CS Type B (1.4mm) | |
| Color / Couleur: Asa-61 Grey | Finish / Fini: Smooth |
| Description: 5412ESFM 30" x 24" x 12" Body | Detail Rev. |
| Part Number / Numéro Pièce: 5412ESFM302412THB | Rev. 3 |

SEE BILL OF MATERIAL ON LAST PAGE

This drawing is confidential and must not be reproduced or used without the consent of EXM

Ce dessin est confidentiel et ne doit pas être reproduit ou utilisé sans le consentement de EXM

| STANDARD FEATURES ARE NOT LISTED IN THIS HOLE TABLE | | | |
|---|--------|--------|--------------------------------|
| HOLE TABLE - TOP VIEW (CUSTOM FEATURE ONLY) | | | |
| CUT-OUT | XDIM | YDIM | DESCRIPTION |
| 1 | 2.000 | 10.500 | INSUL. STUD M6 x 18mm (Inside) |
| 2 | 22.000 | 10.500 | INSUL. STUD M6 x 18mm (Inside) |
| ----- | | | |
| 3 | 6.000 | 11.514 | RND Ø0.290 |
| 4 | 18.000 | 11.514 | RND Ø0.290 |

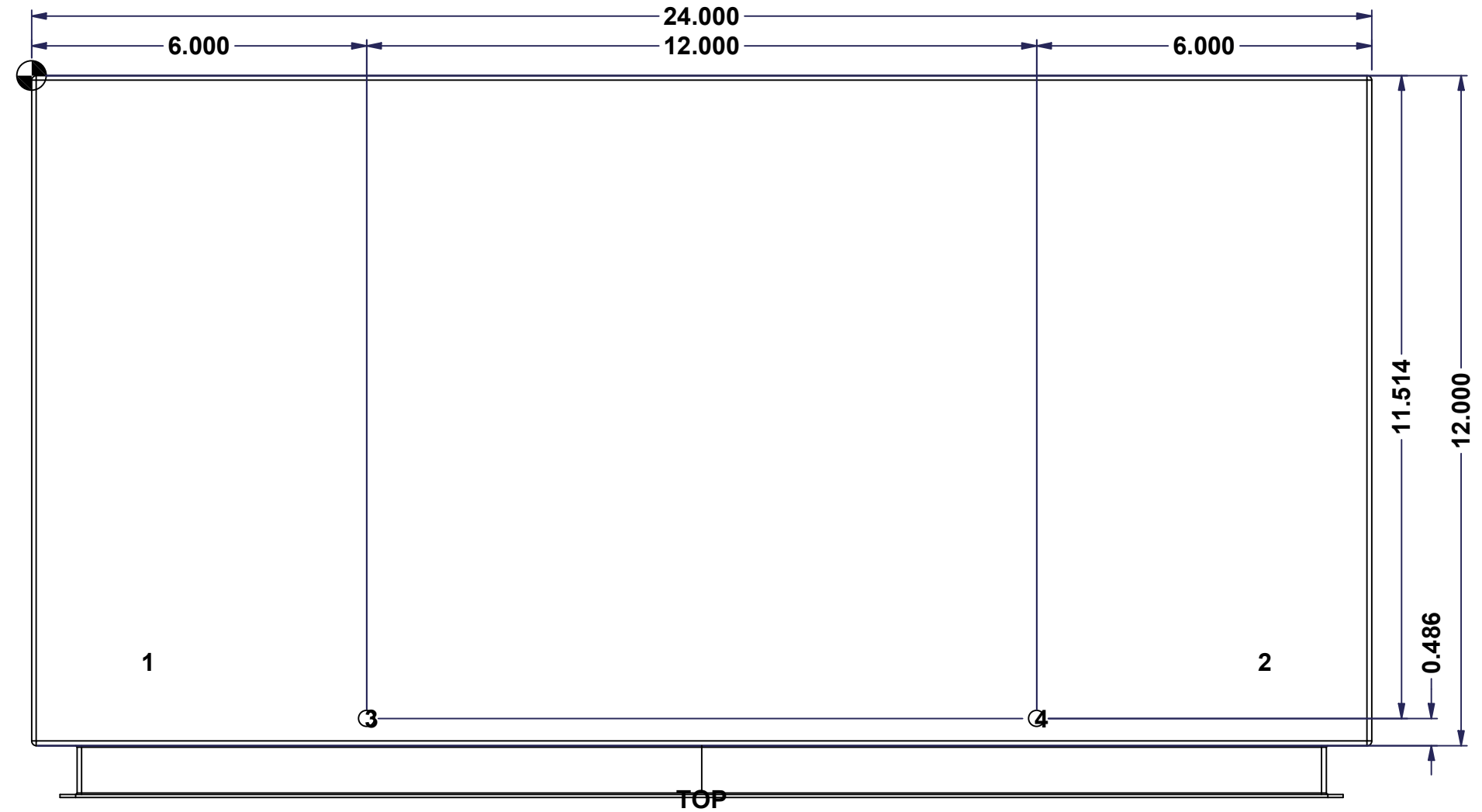

| | | |
|--|-------------------------------|----------|
| | Description | Status |
| | 5412ESFM 30" x 24" x 12" Body | (NULL) |
| | Part Number Numéro Pièce | Rev. |
| | 5412ESFM302412THB | 0 |
| | | 4 |
| | | 19 |

This drawing is confidential and must not be reproduced or used without the consent of EXM

Ce dessin est confidentiel et ne doit pas être reproduit ou utilisé sans le consentement de EXM

| STANDARD FEATURES ARE NOT LISTED IN THIS HOLE TABLE | | | |
|---|--------|--------|-------------|
| HOLE TABLE - RIGHT VIEW (CUSTOM FEATURE ONLY) | | | |
| CUT-OUT | XDIM | YDIM | DESCRIPTION |
| 1 | 11.514 | 24.000 | RND Ø0.290 |
| 2 | 11.514 | 6.000 | RND Ø0.290 |

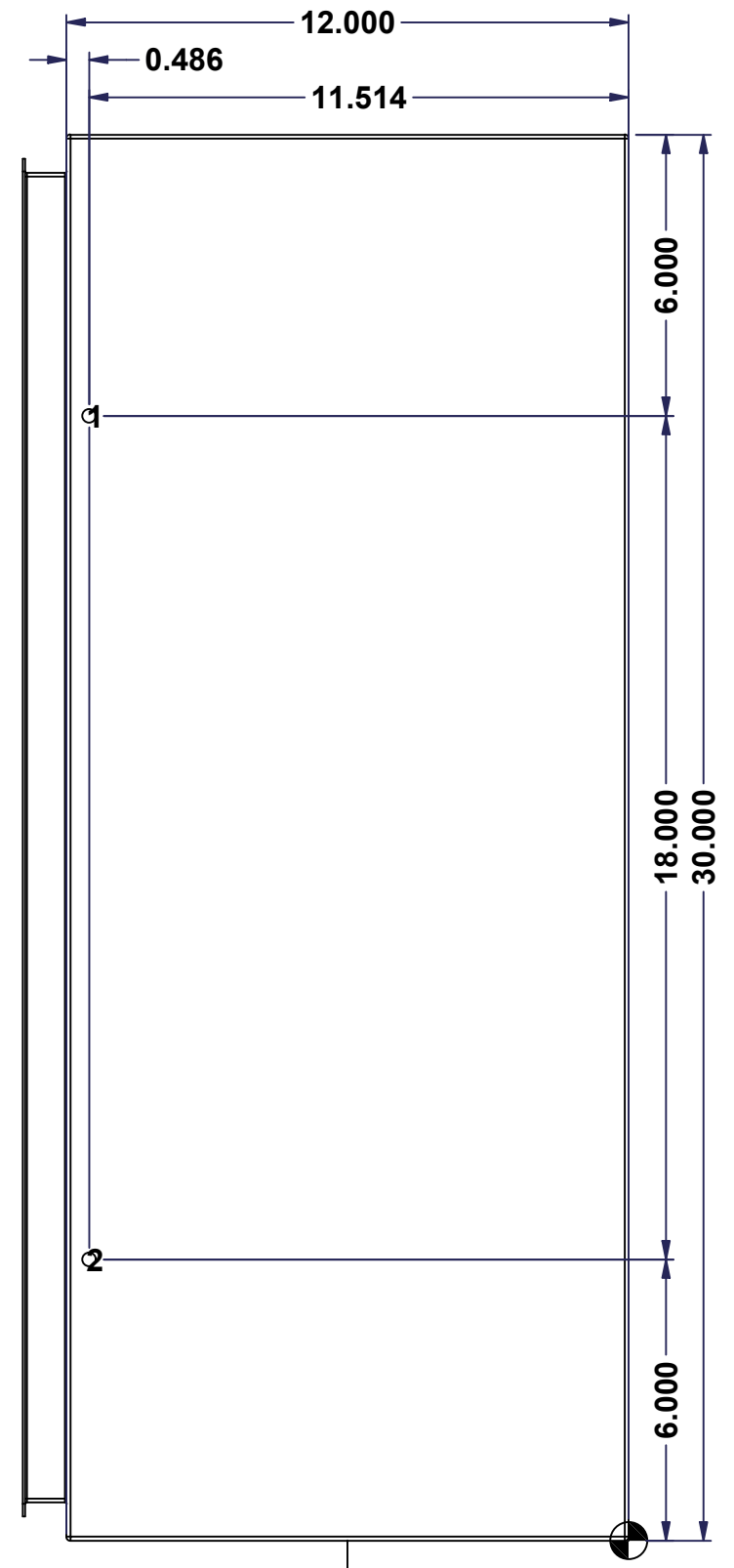

RIGHT

| | | |
|--|-------------------------------|--------------|
| | Description | Status |
| | 5412ESFM 30" x 24" x 12" Body | (NULL) |
| | Part Number Numéro Pièce | Rev. |
| | 5412ESFM302412THB | 0 / 5 |
| | | 19 |

This drawing is confidential and must not be reproduced or used without the consent of EXM

Ce dessin est confidentiel et ne doit pas être reproduit ou utilisé sans le consentement de EXM

| STANDARD FEATURES ARE NOT LISTED IN THIS HOLE TABLE | | | |
|---|--------|--------|--------------------------------|
| HOLE TABLE - BOTTOM VIEW (CUSTOM FEATURE ONLY) | | | |
| CUT-OUT | XDIM | YDIM | DESCRIPTION |
| 1 | 2.000 | 10.500 | INSUL. STUD M6 x 18mm (Inside) |
| 2 | 22.000 | 10.500 | INSUL. STUD M6 x 18mm (Inside) |
| ----- | | | |
| 3 | 6.000 | 11.514 | RND Ø0.290 |
| 4 | 18.000 | 11.514 | RND Ø0.290 |

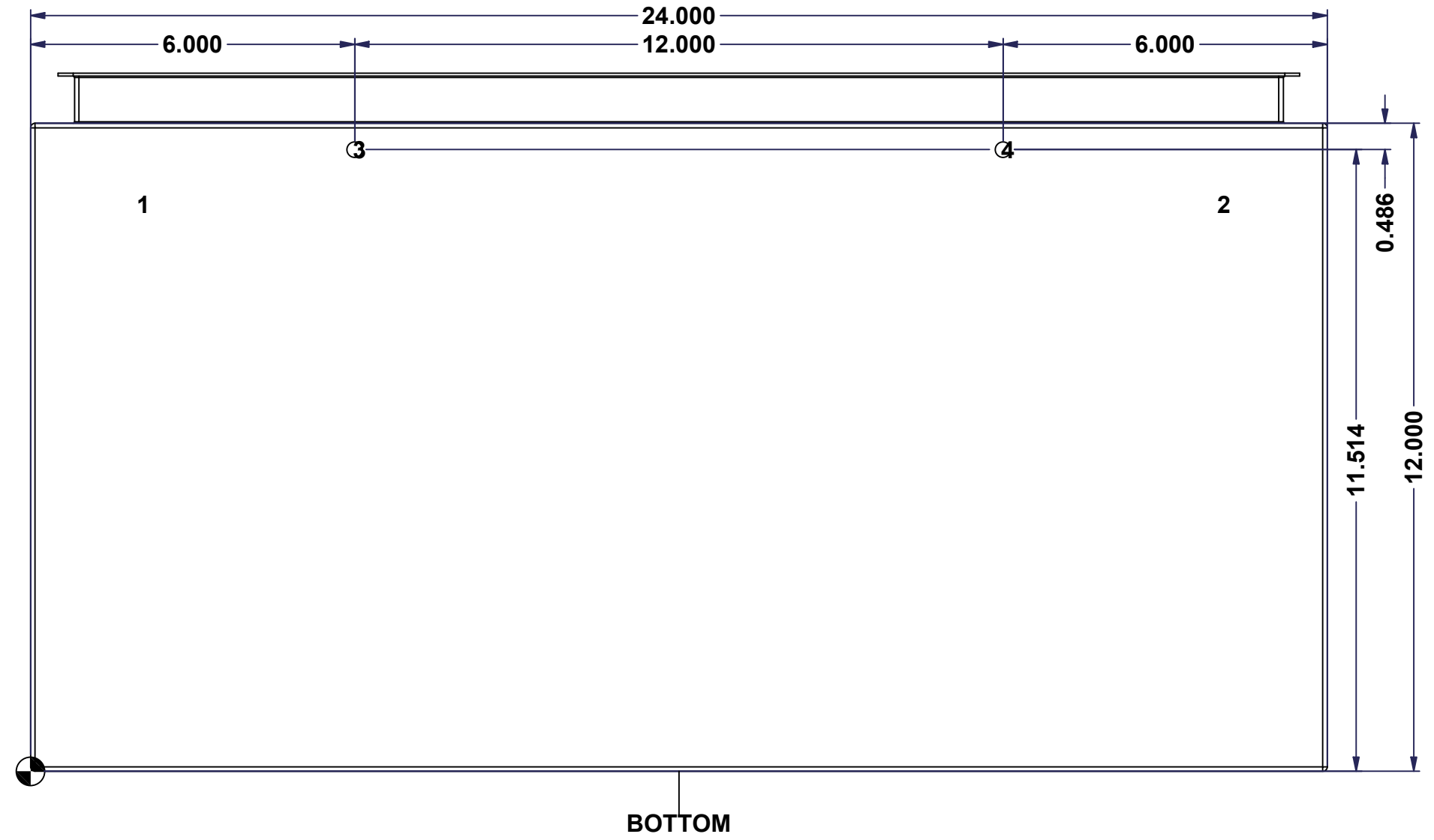

| | | |
|--|-------------------------------|--------------|
| | Description | Status |
| | 5412ESFM 30" x 24" x 12" Body | (NULL) |
| | Part Number Numéro Pièce | Rev. |
| | 5412ESFM302412THB | 0 / 6 |
| | | 19 |

This drawing is confidential and must not be reproduced or used without the consent of EXM

Ce dessin est confidentiel et ne doit pas être reproduit ou utilisé sans le consentement de EXM

| STANDARD FEATURES ARE NOT LISTED IN THIS HOLE TABLE | | | |
|---|--------|--------|-------------|
| HOLE TABLE - LEFT VIEW (CUSTOM FEATURE ONLY) | | | |
| CUT-OUT | XDIM | YDIM | DESCRIPTION |
| 1 | 11.514 | 24.000 | RND Ø0.290 |
| 2 | 11.514 | 6.000 | RND Ø0.290 |

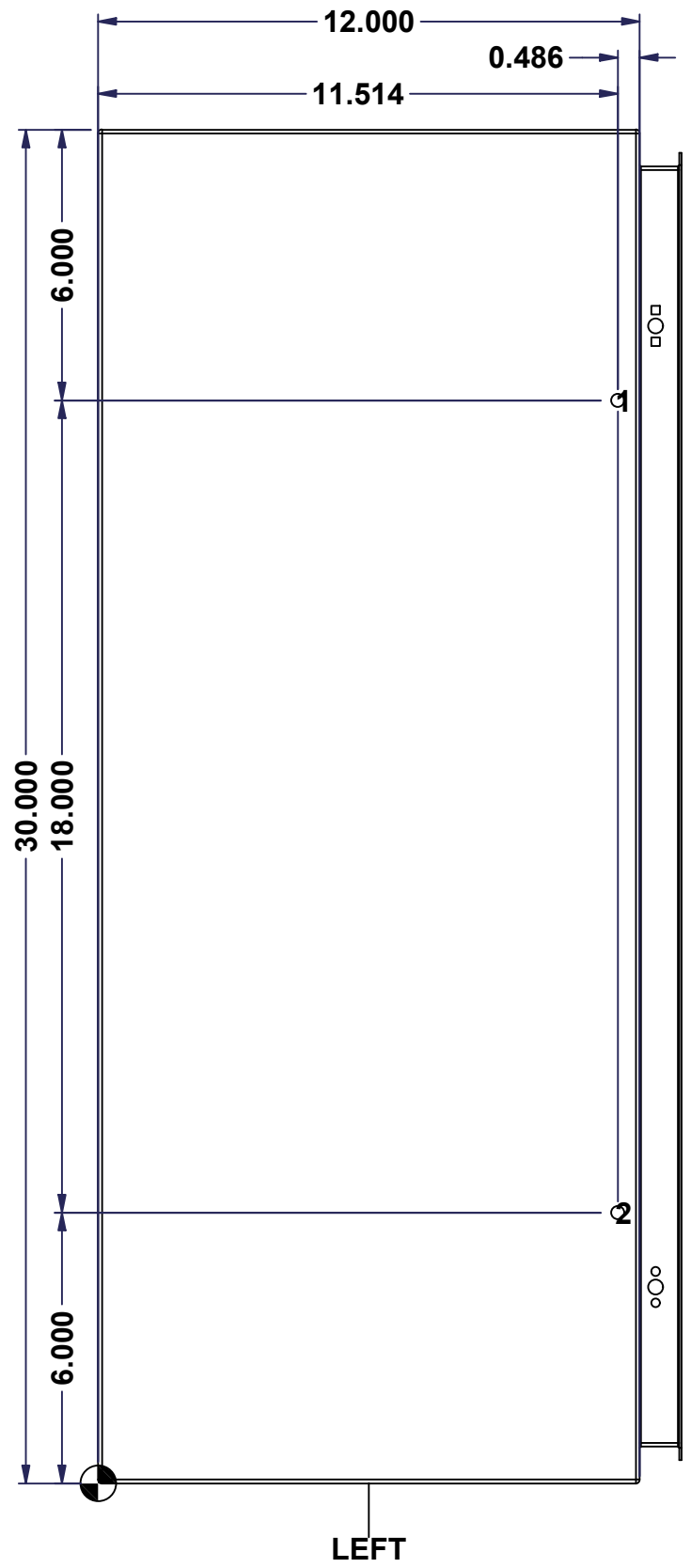

| | | | |
|--|-------------------------------|----------|----|
| | Description | Status | |
| | 5412ESFM 30" x 24" x 12" Body | (NULL) | |
| | Part Number Numéro Pièce | Rev. | 7 |
| | 5412ESFM302412THB | 0 | 19 |

This drawing is confidential and must not be reproduced or used without the consent of EXM

Ce dessin est confidentiel et ne doit pas être reproduit ou utilisé sans le consentement de EXM

STANDARD FEATURES ARE NOT LISTED IN THIS HOLE TABLE

HOLE TABLE - BACK VIEW (CUSTOM FEATURE ONLY)

| CUT-OUT | XDIM | YDIM | DESCRIPTION |
|---------|--------|--------|----------------------------|
| 1 | 1.875 | 1.875 | IP STUD M8 x 35mm (Inside) |
| 2 | 1.875 | 28.125 | IP STUD M8 x 35mm (Inside) |
| 3 | 22.125 | 28.125 | IP STUD M8 x 35mm (Inside) |
| 4 | 22.125 | 1.875 | IP STUD M8 x 35mm (Inside) |
| ----- | | | |
| 5 | 23.250 | 0.750 | RND Ø0.390 |
| 6 | 23.250 | 29.250 | RND Ø0.390 |
| 7 | 0.750 | 29.250 | RND Ø0.390 |
| 8 | 0.750 | 0.750 | RND Ø0.390 |

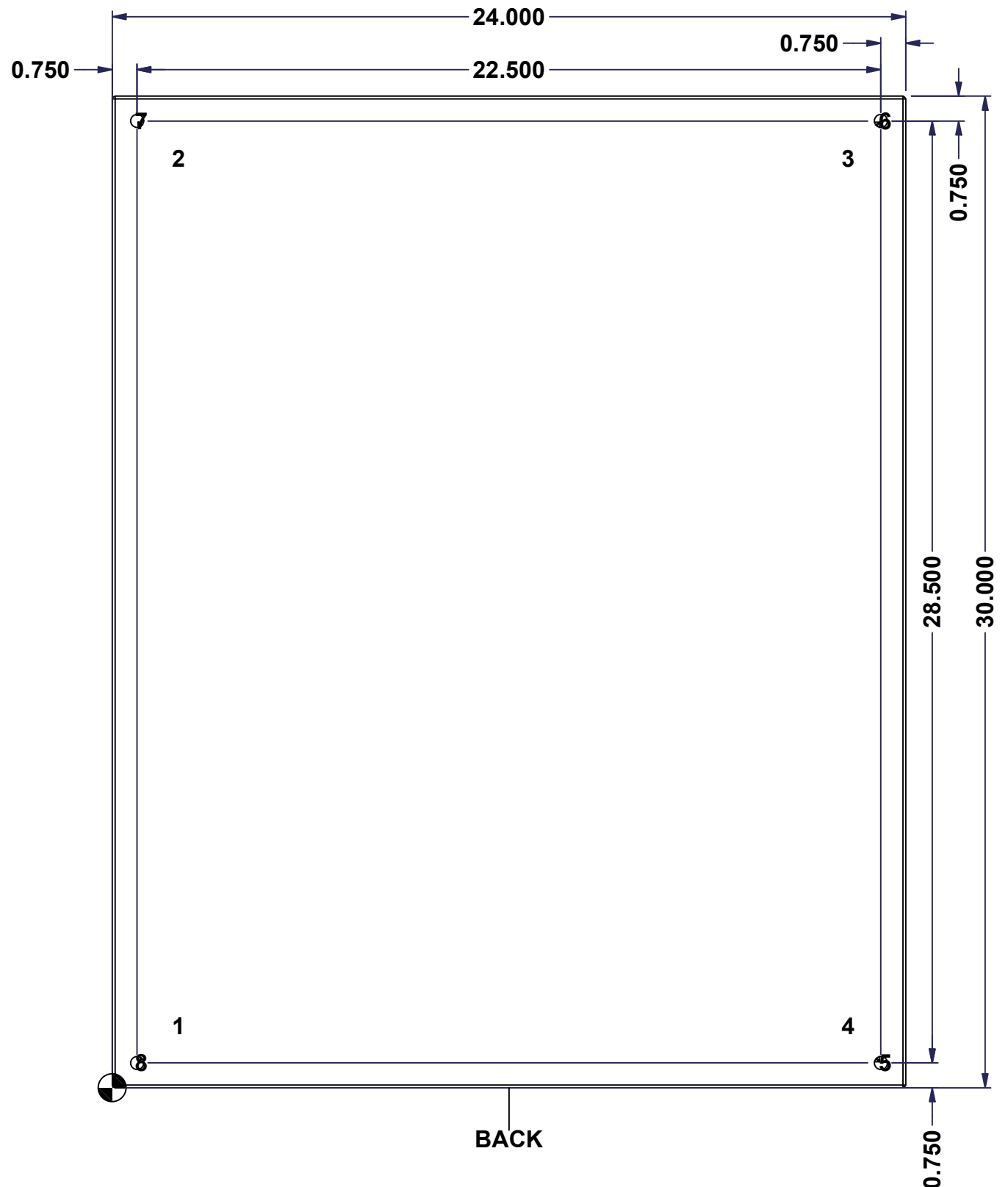

| | | |
|---|-------------------------------|--------|
| | Description | Status |
| | 5412ESFM 30" x 24" x 12" Body | (NULL) |
| Part Number Numéro Pièce 5412ESFM302412THB | Rev. | 8 |
| | 0 | 19 |

This drawing is confidential and must not be reproduced or used without the consent of EXM

Ce dessin est confidentiel et ne doit pas être reproduit ou utilisé sans le consentement de EXM

| STANDARD FEATURES ARE NOT LISTED IN THIS HOLE TABLE | | | |
|---|--------|--------|-------------|
| HOLE TABLE - FRONT VIEW (CUSTOM FEATURE ONLY) | | | |
| CUT-OUT | XDIM | YDIM | DESCRIPTION |
| 1 | 0.500 | 0.500 | RND Ø0.290 |
| 2 | 0.500 | 32.000 | RND Ø0.290 |
| 3 | 26.000 | 0.500 | RND Ø0.290 |
| 4 | 26.000 | 32.000 | RND Ø0.290 |

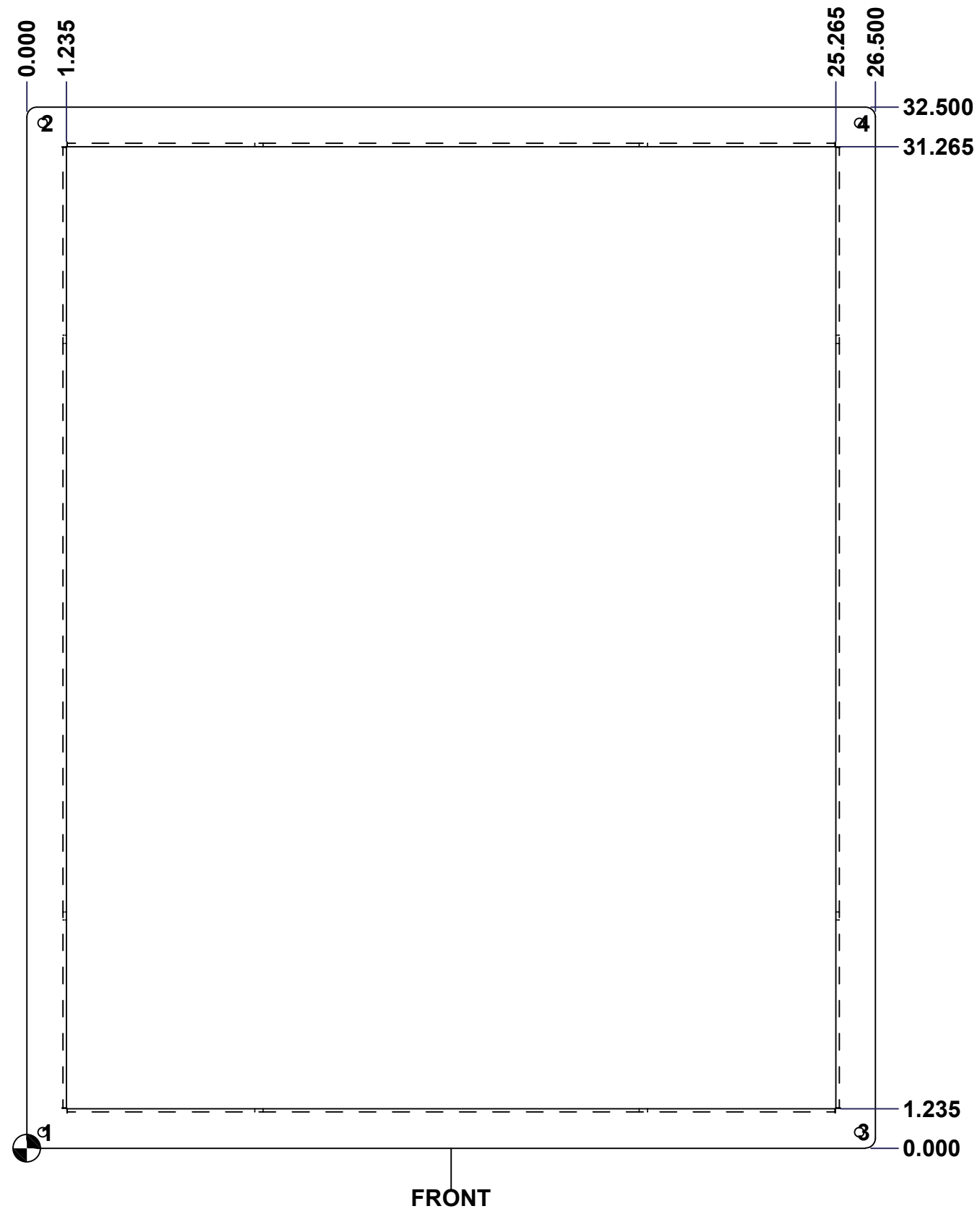

| | | |
|--|---------------------------------|--------------|
| | Description | Status |
| | 5412ESFM 30" x 24" x 12" Flange | (NULL) |
| | Part Number Numéro Pièce | Rev. |
| | 5412ESFM302412THB | 0 / 9 |
| | | 19 |

This drawing is confidential and must not be reproduced or used without the consent of EXM

Ce dessin est confidentiel et ne doit pas être reproduit ou utilisé sans le consentement de EXM

| No. | Revisions | Date | By/Par |
|-----|-----------|------|--------|
| | | | |
| | | | |
| | | | |
| | | | |
| | | | |

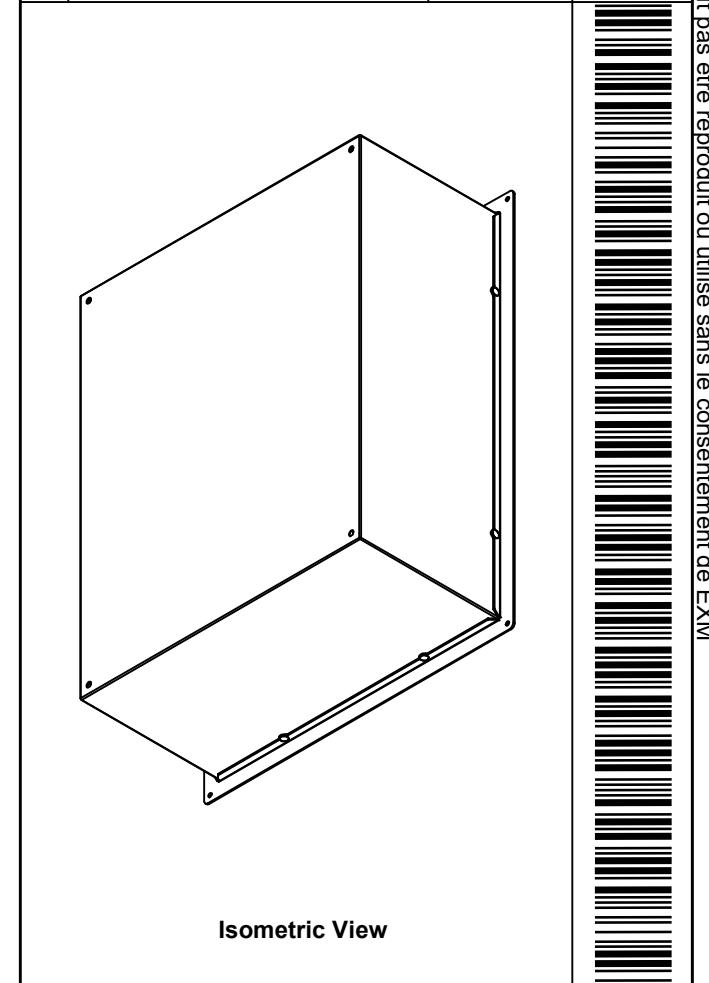

| 1 | STK-K-70554 | 3 | 5412 ESTH Accessory Kit |
|------------|----------------------|-----|--|
| 1 | 5412ESFM302412THI-RS | 0 | 5412ESFM 30" x 24" Right Insulation |
| 1 | 5412ESFM302412THI-LS | 0 | 5412ESFM 30" x 24" Left Insulation |
| 1 | 5412ESFM302412THI-BT | 0 | 5412ESFM 30" x 24"Bottom Insulation |
| 1 | 5412ESFM302412THI-TP | 0 | 5412ESFM 30" x 24"Top Insulation |
| 1 | 5412ESFM302412THI-B | 0 | 5412ESFM 30" x 24" Back Insulation |
| 4 | STK-Q-16055 | 1 | M6 x 18mm Stud (No Paint Cap Required) |
| 1 | 5412ESFM302412THF | 0 | 5412ESFM 30" x 24" x 12" Flange |
| 1 | STK-P-02400S | 0 | Powder Paint (Asa-61 Grey / Smooth) |
| 4 | STK-Q-16005 | 0 | Stud M8 x 35mm Steel |
| 1 | 5412ESFM302412THB-P | 0 | 5412ESFM 30" x 24" x 12" Body Part |
| Qty | Part Number | Rev | Description |
| Parts List | | | |

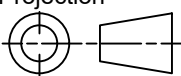
| | | |
|--|---|---|
|  Tél: (450) 979-4373 Fax: (450) 979-4626 www.exmweb.com | | Flatness Aplatissement Max 3.0mm Projection  |
| Customer Client | Date | Date 23-Dec-24 |
| Drawn By Dessiné Par | BoxCad: BoxCad | |
| Material Matière | 16 Ga Cold Rolled A1008 CS Type B (1.4mm) | |
| Color Couleur | Asa-61 Grey | Finish Fini Smooth |
| Description | Detail Rev. | |
| 5412ESFM 30" x 24" x 12" Body | | |
| Part Number Numéro Pièce | Rev. | 10 |
| 5412ESFM302412THB | 0 | 19 |

This drawing is confidential and must not be reproduced or used without the consent of EXM

Ce dessin est confidentiel et ne doit pas être reproduit ou utilisé sans le consentement de EXM

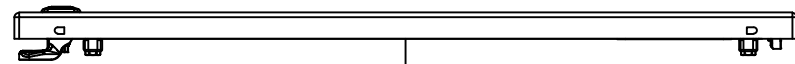

TOP

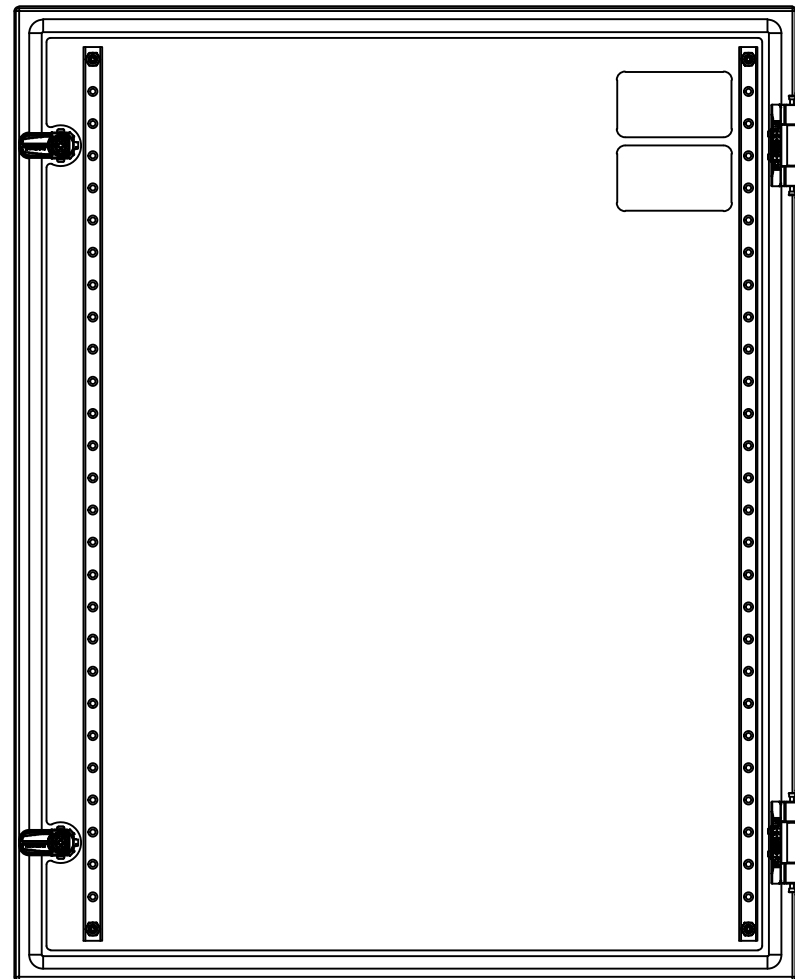

BACK

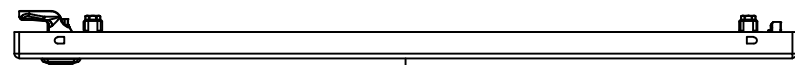

BOTTOM

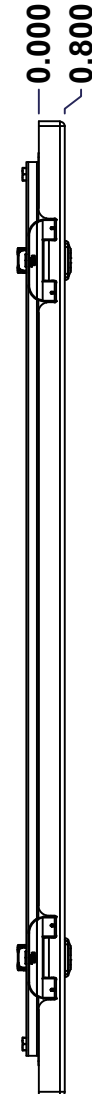

LEFT

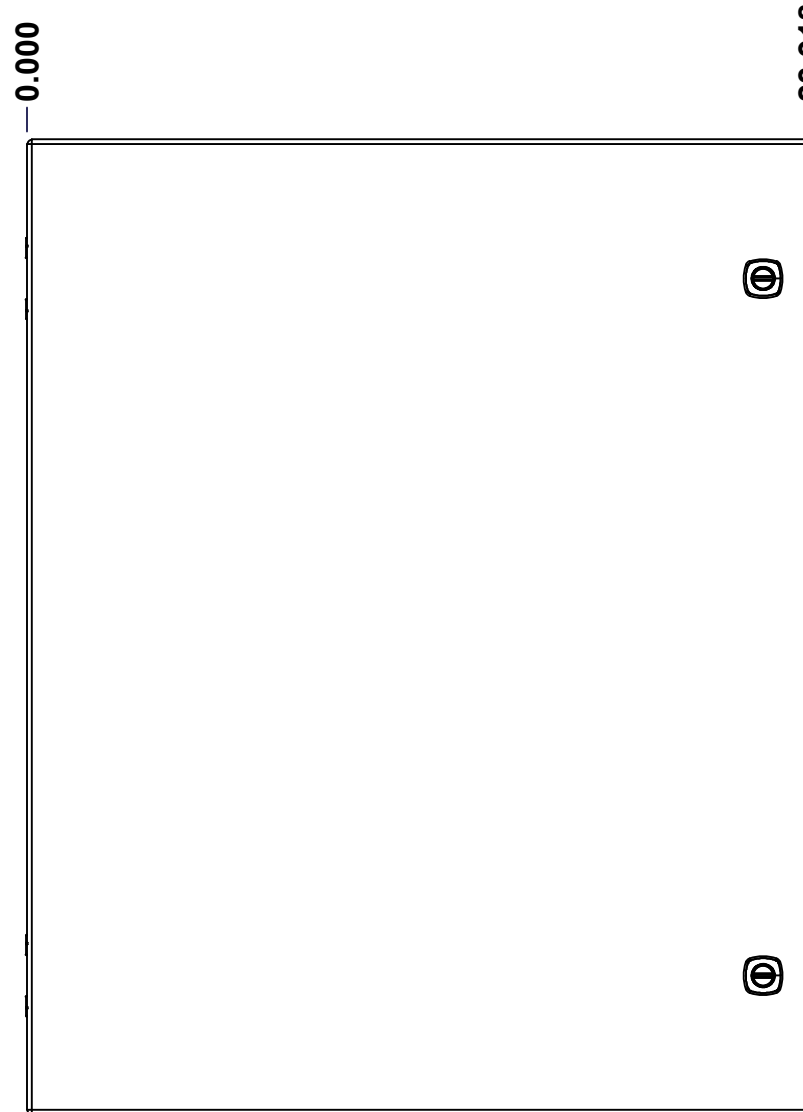

FRONT

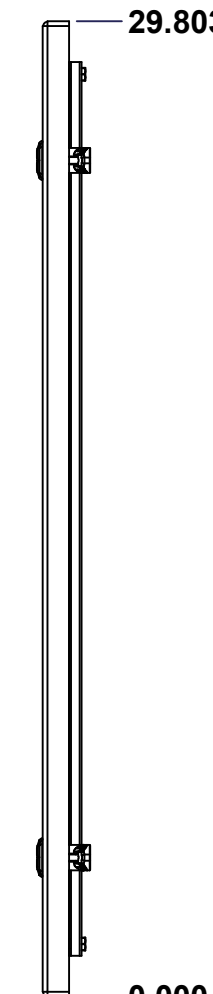

RIGHT

| No. | Revisions | Date | By/Par |
|-----|-----------|------|--------|
| | | | |
| | | | |
| | | | |
| | | | |
| | | | |

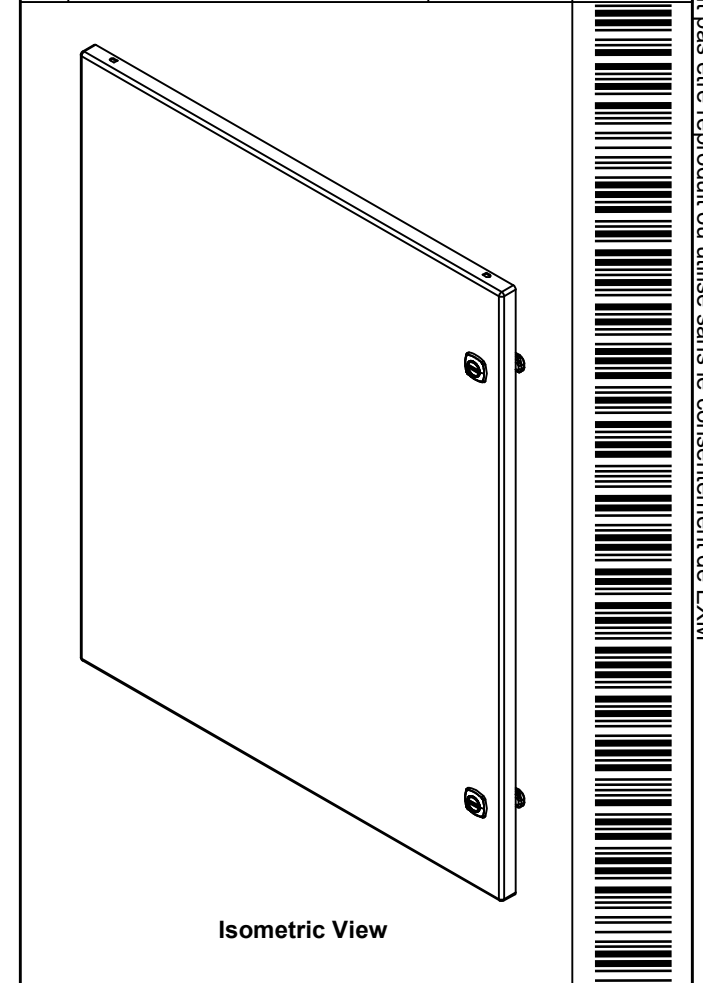

Isometric View

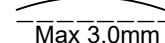
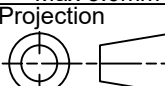
| | | |
|--|---|---|
|  Tél: (450) 979-4373 Fax: (450) 979-4626 www.exmweb.com | | Flatness Aplatissement  Max 3.0mm |
| Projection  | | Date Date 23-Dec-24 |
| Customer Client | Date | |
| Drawn By Dessiné Par | BoxCad: BoxCad | Date 23-Dec-24 |
| Material Matière | 16 Ga Cold Rolled A1008 CS Type B (1.4mm) | |
| Color Couleur | Asa-61 Grey | Finish Fini Smooth |
| Description | Detail Rev. | |
| 5412ESFM 30" x 24" Cover | | |
| Part Number Numéro Pièce | Rev. 0 | 11 19 |

SEE BILL OF MATERIAL ON LAST PAGE

5412ESFM302412THC

This drawing is confidential and must not be reproduced or used without the consent of EXM

Ce dessin est confidentiel et ne doit pas être reproduit ou utilisé sans le consentement de EXM

STANDARD FEATURES ARE NOT LISTED IN THIS HOLE TABLE

HOLE TABLE - FRONT VIEW (CUSTOM FEATURE ONLY)

| CUT-OUT | XDIM | YDIM | DESCRIPTION |
|---------|--------|--------|-------------------------|
| 1 | 1.486 | 1.614 | STUD M6 x 18mm (Inside) |
| 2 | 1.486 | 28.189 | STUD M6 x 18mm (Inside) |
| 3 | 21.517 | 28.189 | STUD M6 x 18mm (Inside) |
| 4 | 21.517 | 1.614 | STUD M6 x 18mm (Inside) |
| ----- | | | |
| 5 | 22.494 | 25.553 | LOCK 880 SCQ4-SL @ 0.0° |
| 6 | 22.494 | 4.250 | LOCK 880 SCQ4-SL @ 0.0° |

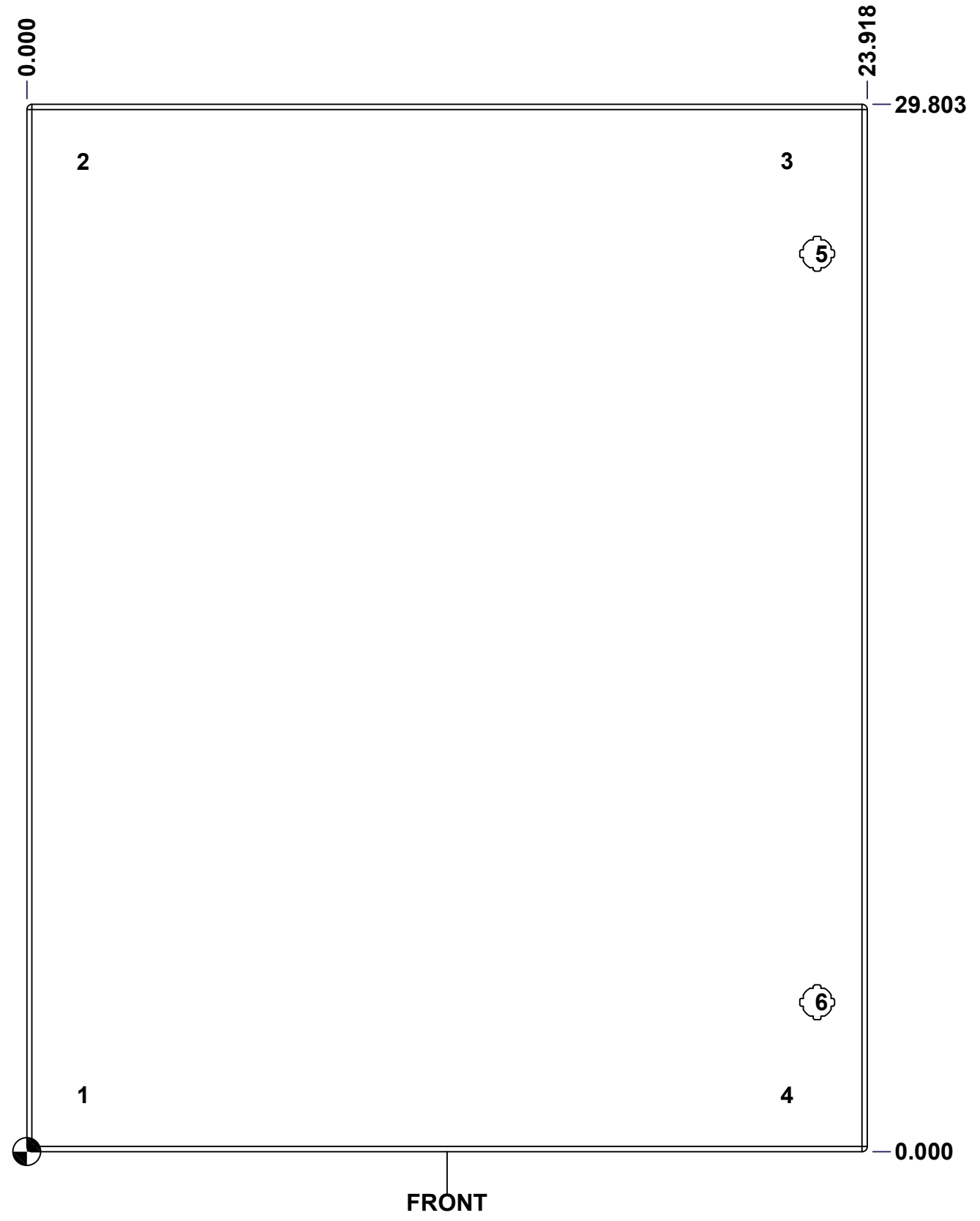

FRONT

| | | |
|--|-----------------------------|----------|
| | Description | Status |
| | 5412ESFM 30" x 24" Cover | (NULL) |
| | Part Number Numéro Pièce | Rev. |
| | 5412ESFM302412THC | 0 |
| | | 12 |
| | | 19 |

This drawing is confidential and must not be reproduced or used without the consent of EXM

Ce dessin est confidentiel et ne doit pas être reproduit ou utilisé sans le consentement de EXM

| No. | Revisions | Date | By/Par |
|-----|-----------|------|--------|
| | | | |
| | | | |
| | | | |
| | | | |
| | | | |

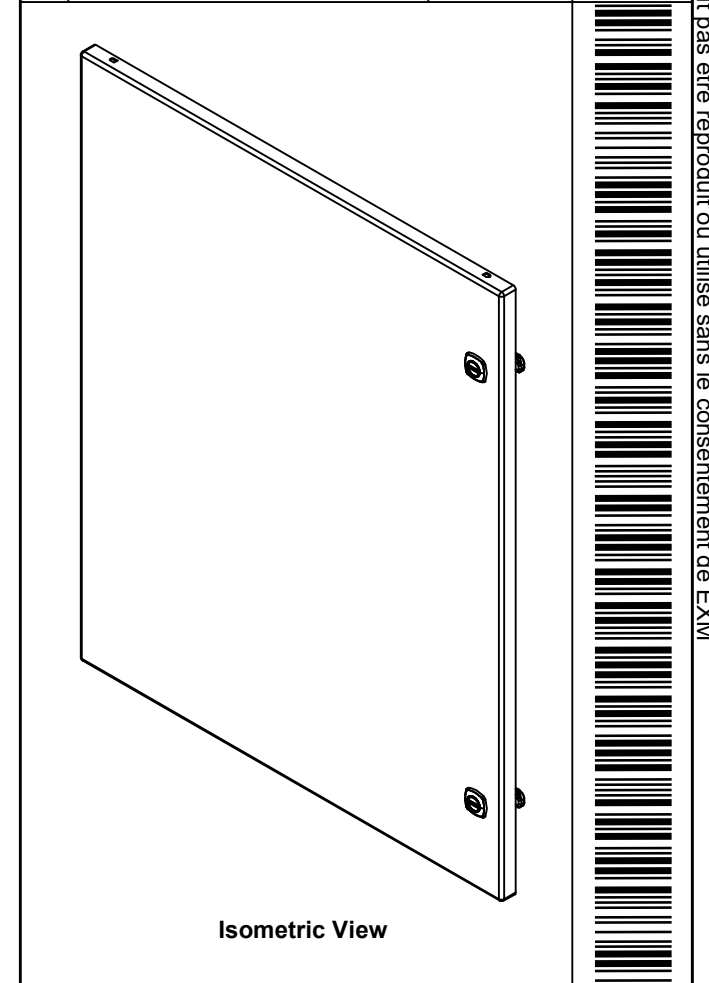

 Tél: (450) 979-4373
 Fax: (450) 979-4626
www.exmweb.com

Flatness
 Aplatissement
 Max 3.0mm
Projection

| QTY | Part Number | Rev | Description |
|------------|---------------------|-----|---|
| 2 | STK-K-12500 | 19 | 5412 ES 1/4 Turn Lock |
| 2 | STK-S-00100 | 0 | 3.5" x 2" Silver Milar Flexcon Sticker |
| 4 | STK-Q-07250 | 2 | M6 x 16mm Collar Nut |
| 2 | STK-Q-46020-30 | 6 | 5412 ES Vertical Door Stiffener 30" |
| 1 | 5412ESFM302412THI-C | 0 | 5412ESFM 30" x 24" Cover Insulation |
| 1 | STK-P-02400S | 0 | Powder Paint (Asa-61 Grey / Smooth) |
| 4 | STK-Q-16055 | 1 | M6 x 18mm Stud (No Paint Cap Required) |
| 1 | 5412ESFM302412THG | 0 | 5412ESFM 30" x 24" Cover Gasket Part |
| 1 | 5412ESFM302412THC-P | 0 | 5412ESFM 30" x 24" Cover Part |
| 2 | STK-K-09800 | 10 | 5412 ES Hinge with 2 Captive Hinge Pins |
| Parts List | | | |

| | |
|---|-----------------------|
| Customer Client | Date |
| Drawn By / Dessiné Par: BoxCad: BoxCad | Date: 23-Dec-24 |
| Material / Matière: 16 Ga Cold Rolled A1008 CS Type B (1.4mm) | |
| Color / Couleur: Asa-61 Grey | Finish / Fini: Smooth |
| Description: 5412ESFM 30" x 24" Cover | Detail Rev. |
| Part Number / Numéro Pièce: 5412ESFM302412THC | Rev. 0 |
| | 13 / 19 |

This drawing is confidential and must not be reproduced or used without the consent of EXM

Ce dessin est confidentiel et ne doit pas être reproduit ou utilisé sans le consentement de EXM

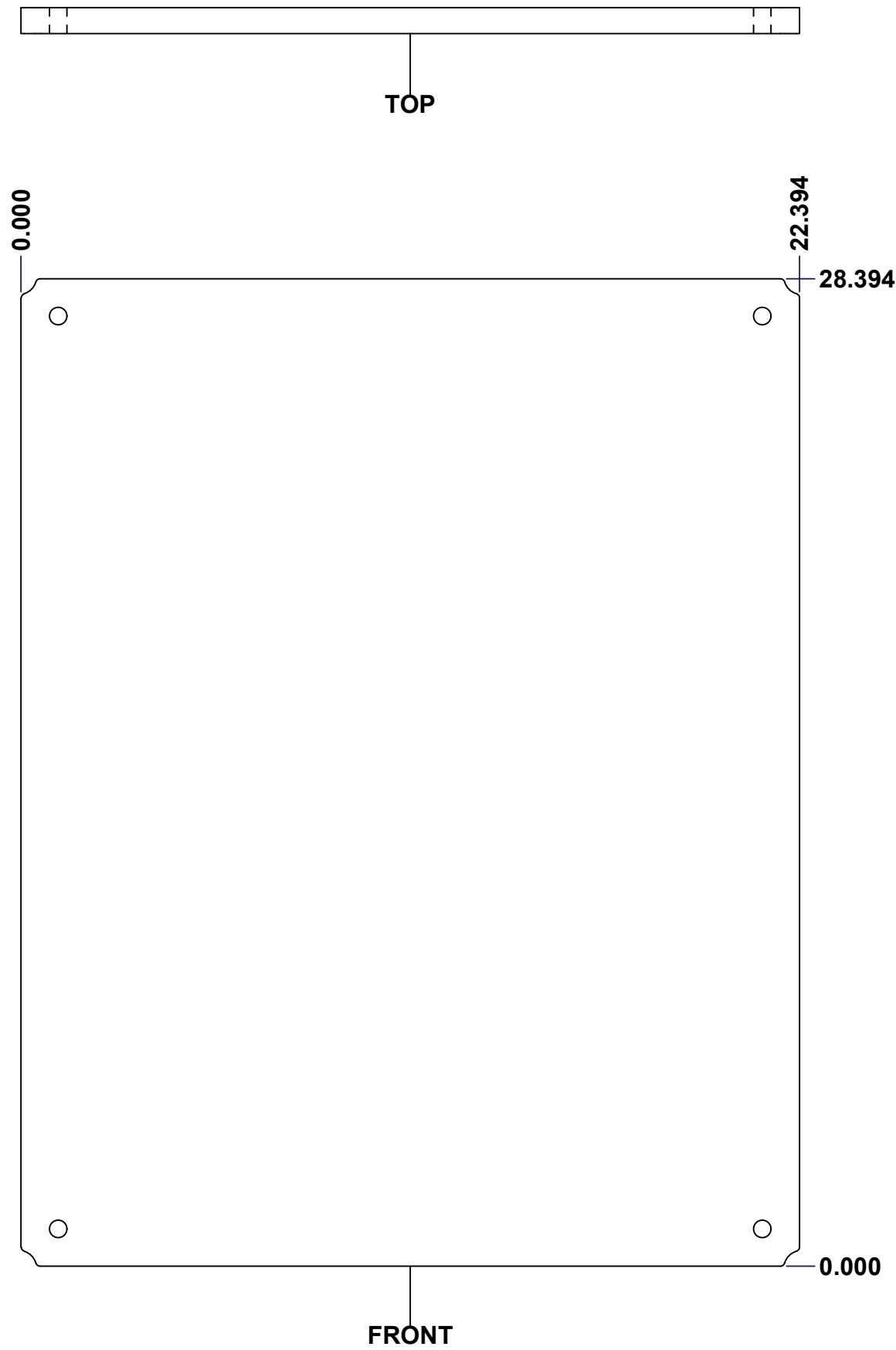

| No. | Revisions | Date | By/Par |
|-----|-----------|------|--------|
| | | | |
| | | | |
| | | | |
| | | | |
| | | | |

Isometric View

| | | |
|---|---------------------------|--|
| <p>Tél: (450) 979-4373 Fax: (450) 979-4626 www.exmweb.com</p> | | Flatness Aplatissement Max 3.0mm Projection |
| Customer Client | Date | |
| Drawn By Dessiné Par | BoxCad: Patrick Deschenes | Date 23-Jan-07 |
| Material Matière | Polyisocyanurate | |
| Color Couleur | Aluminum | Finish Fini N/A |
| Description 5412ESFM 30" x 24" Back Insulation | | Detail Rev. |
| Part Number Numéro Pièce | Rev. 0 | 14 19 |

SEE BILL OF MATERIAL ON LAST PAGE

5412ESFM302412THI-B

This drawing is confidential and must not be reproduced or used without the consent of EXM

Ce dessin est confidentiel et ne doit pas être reproduit ou utilisé sans le consentement de EXM

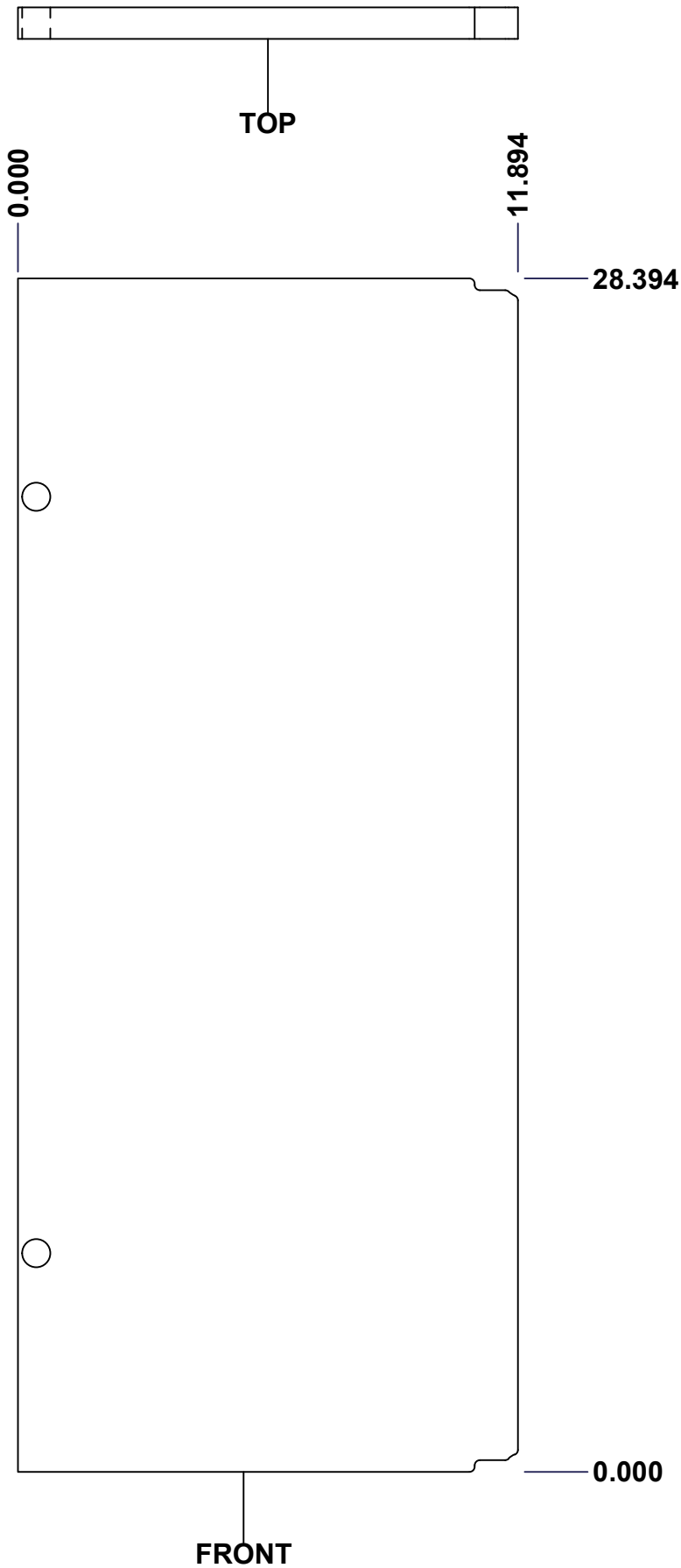

| No. | Revisions | Date | By/Par |
|-----|-----------|------|--------|
| | | | |
| | | | |
| | | | |
| | | | |
| | | | |

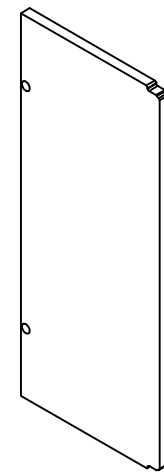

Isometric View



Tél: (450) 979-4373
 Fax: (450) 979-4626
www.exmweb.com

Flatness
Aplatissement
Max 3.0mm
Projection

| | |
|---|-----------------|
| Customer Client | Date |
| Drawn By / Dessiné Par: BoxCad: Patrick Deschenes | Date: 23-Jan-07 |
| Material / Matière: Polyisocyanurate | |

| | |
|---------------------------|--------------------|
| Color / Couleur: Aluminum | Finish / Fini: N/A |
|---------------------------|--------------------|

| | |
|---|-------------|
| Description: 5412ESFM 30" x 24" Left Insulation | Detail Rev. |
|---|-------------|

| | | |
|--|--------|---------|
| Part Number / Numéro Pièce: 5412ESFM302412THI-LS | Rev. 0 | 15 / 19 |
|--|--------|---------|

SEE BILL OF MATERIAL ON LAST PAGE

This drawing is confidential and must not be reproduced or used without the consent of EXM

Ce dessin est confidentiel et ne doit pas être reproduit ou utilisé sans le consentement de EXM

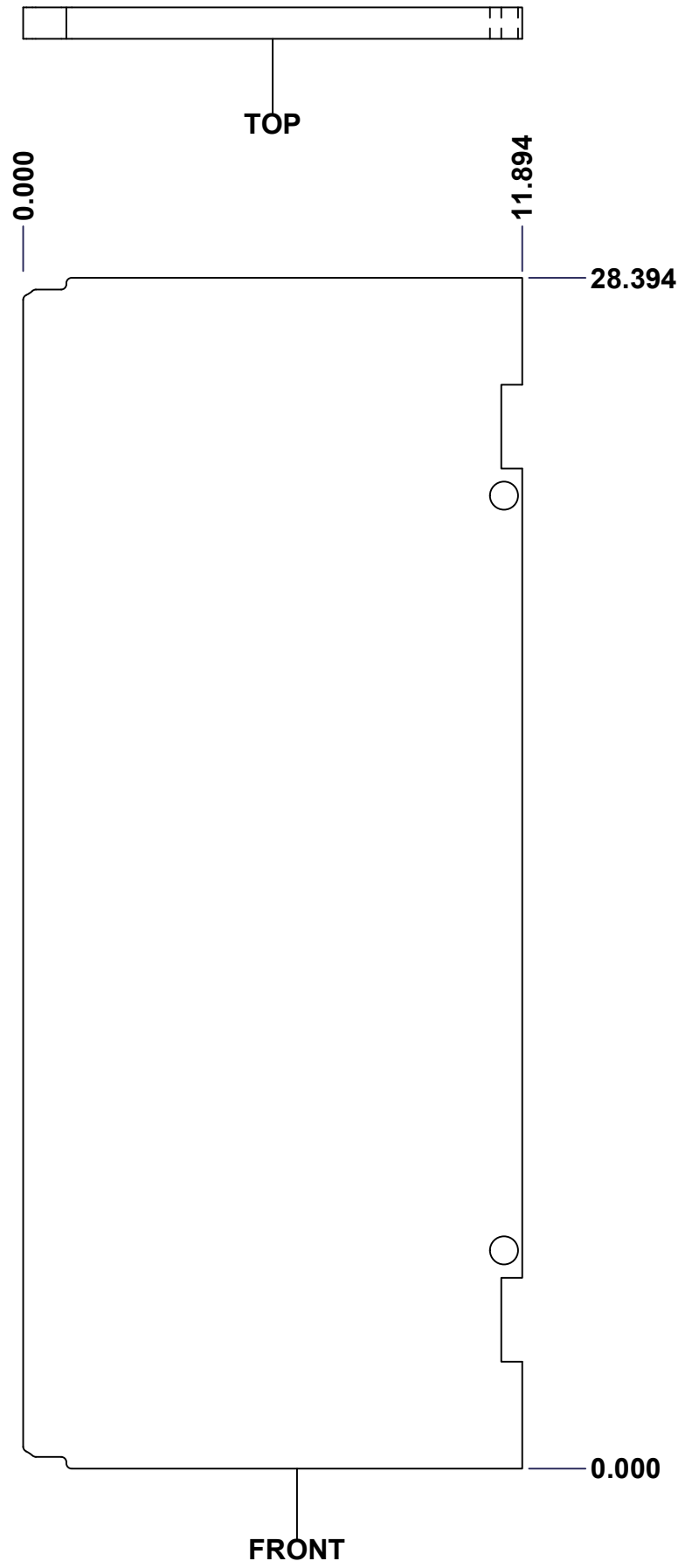

| No. | Revisions | Date | By/Par |
|-----|-----------|------|--------|
| | | | |
| | | | |
| | | | |
| | | | |
| | | | |

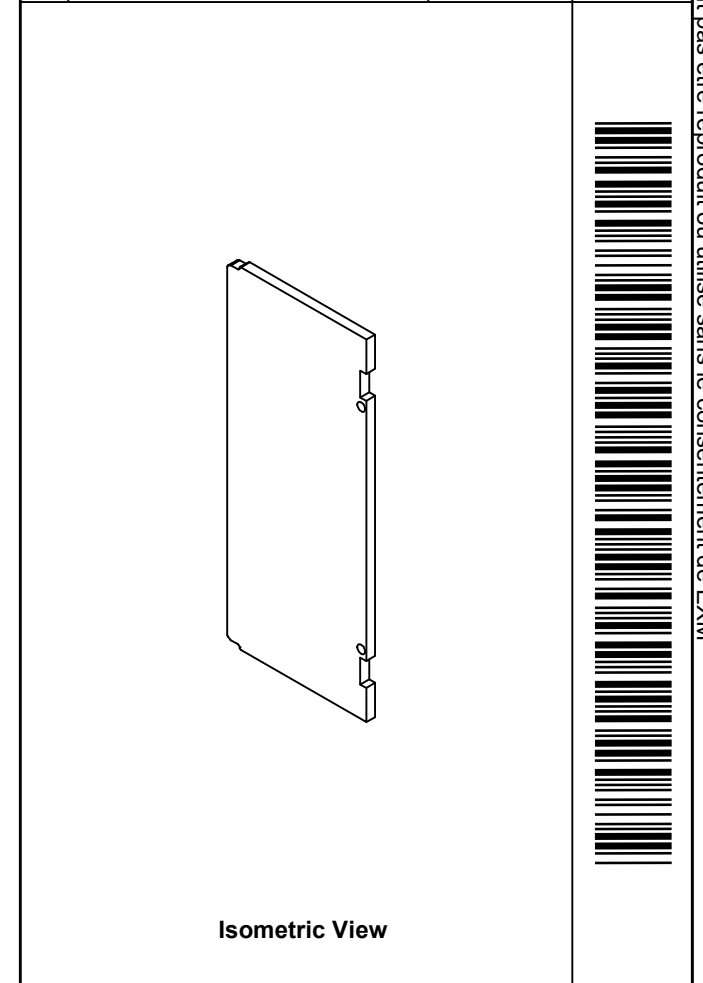

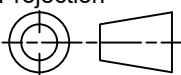
| | | |
|--|--------------------|---|
|  Tél: (450) 979-4373 Fax: (450) 979-4626 www.exmweb.com | | Flatness Aplatissement Max 3.0mm Projection  |
| Customer Client | Date | |
| Drawn By / Dessiné Par: BoxCad: Patrick Deschenes | Date: 23-Jan-07 | |
| Material / Matière: Polyisocyanurate | | |
| Color / Couleur: Aluminum | Finish / Fini: N/A | |
| Description: 5412ESFM 30" x 24" Right Insulation | | Detail Rev. |
| Part Number / Numéro Pièce: 5412ESFM302412THI-RS | Rev. 0 | 16 / 19 |

SEE BILL OF MATERIAL ON LAST PAGE

This drawing is confidential and must not be reproduced or used without the consent of EXM

Ce dessin est confidentiel et ne doit pas être reproduit ou utilisé sans le consentement de EXM

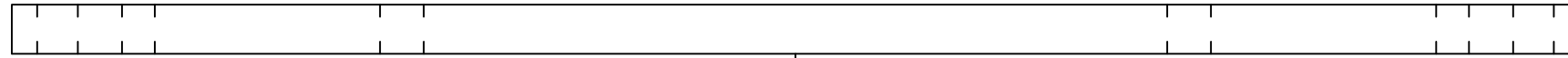

TOP

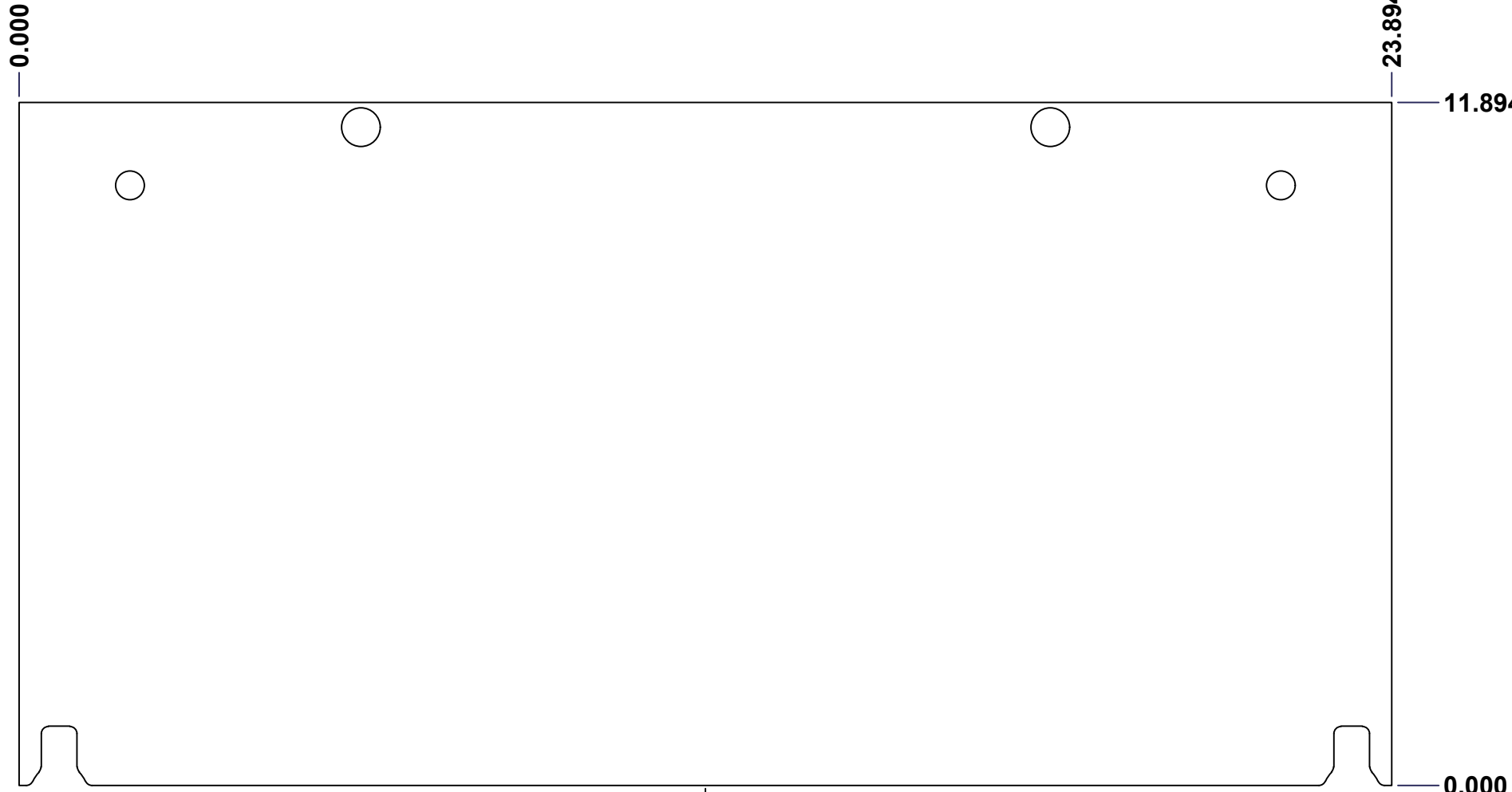

FRONT



RIGHT

| No. | Revisions | Date | By/Par |
|-----|-----------|------|--------|
| | | | |
| | | | |
| | | | |
| | | | |

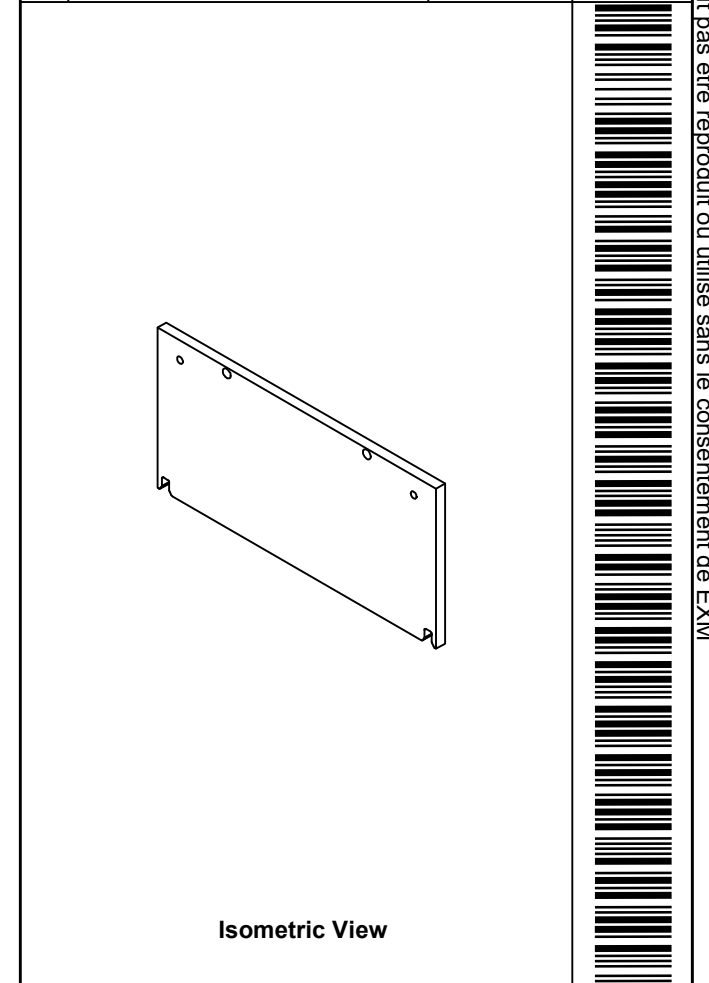

Isometric View



Tél: (450) 979-4373
 Fax: (450) 979-4626
www.exmweb.com

Flatness
Aplatissement

Max 3.0mm

Projection

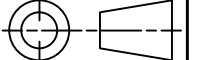

| | |
|---|-----------------------|
| Customer Client | Date |
| Drawn By Dessiné Par BoxCad: BoxCad | Date 4/3/2024 |
| Material Matière Polyisocyanurate | |
| Color Couleur Aluminum | Finish Fini Smooth |
| Description 5412ESFM 30" x 24"Top Insulation | Detail Rev. |
| Part Number Numéro Pièce 5412ESFM302412THI-TP | Rev. 0 |

17
19

SEE BILL OF MATERIAL ON LAST PAGE

This drawing is confidential and must not be reproduced or used without the consent of EXM

Ce dessin est confidentiel et ne doit pas être reproduit ou utilisé sans le consentement de EXM

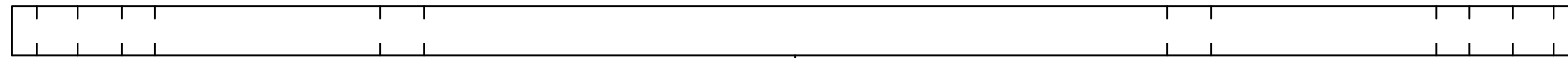

TOP

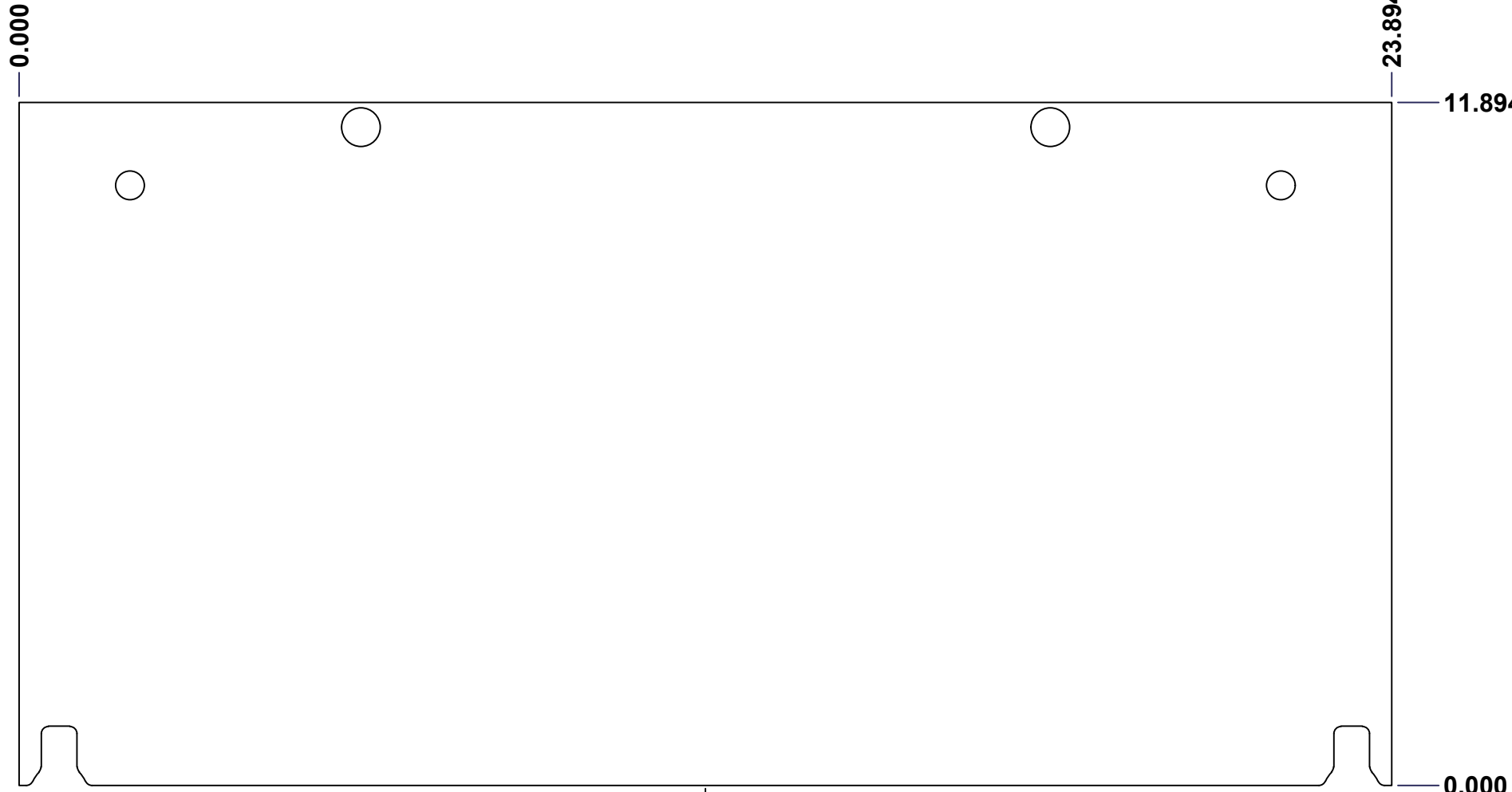

FRONT

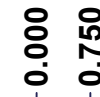

RIGHT

| No. | Revisions | Date | By/Par |
|-----|-----------|------|--------|
| | | | |
| | | | |
| | | | |
| | | | |

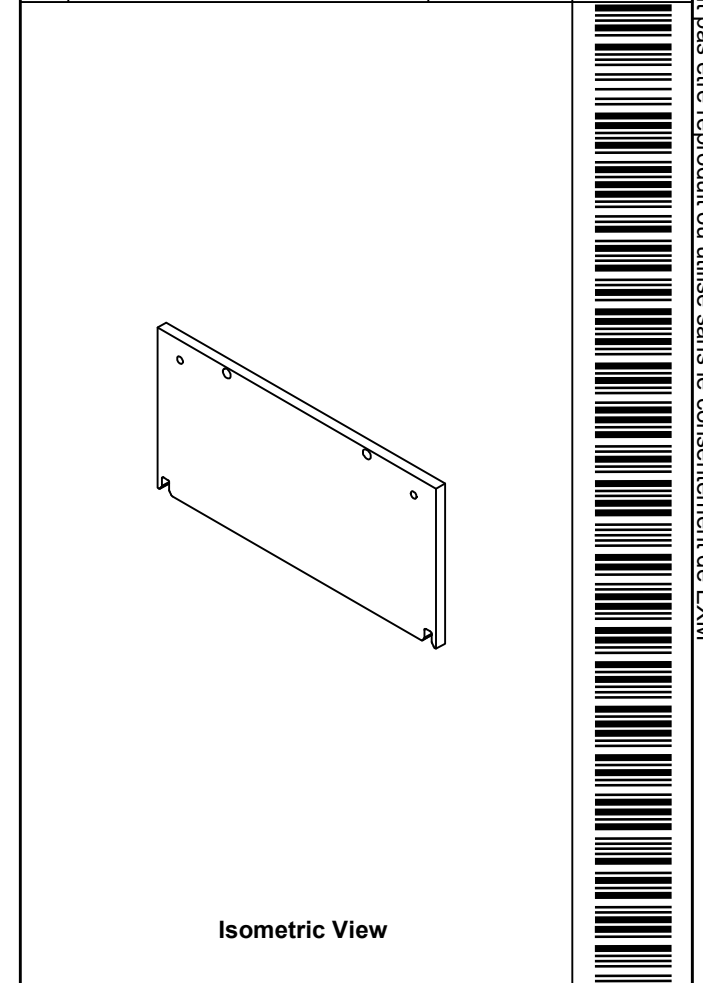

Isometric View



Tél: (450) 979-4373
 Fax: (450) 979-4626
www.exmweb.com

Flatness
 Aplatissement
 Max 3.0mm
 Projection

| | |
|--|-----------------------|
| Customer Client | Date |
| Drawn By / Dessiné Par: BoxCad: BoxCad | Date: 4/3/2024 |
| Material / Matière: Polyisocyanurate | |
| Color / Couleur: Aluminum | Finish / Fini: Smooth |
| Description: 5412ESFM 30" x 24"Bottom Insulation | Detail Rev. |
| Part Number / Numéro Pièce: 5412ESFM302412THI-BT | Rev. 0 |

SEE BILL OF MATERIAL ON LAST PAGE

This drawing is confidential and must not be reproduced or used without the consent of EXM

Ce dessin est confidentiel et ne doit pas être reproduit ou utilisé sans le consentement de EXM

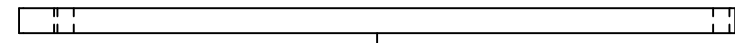

TOP

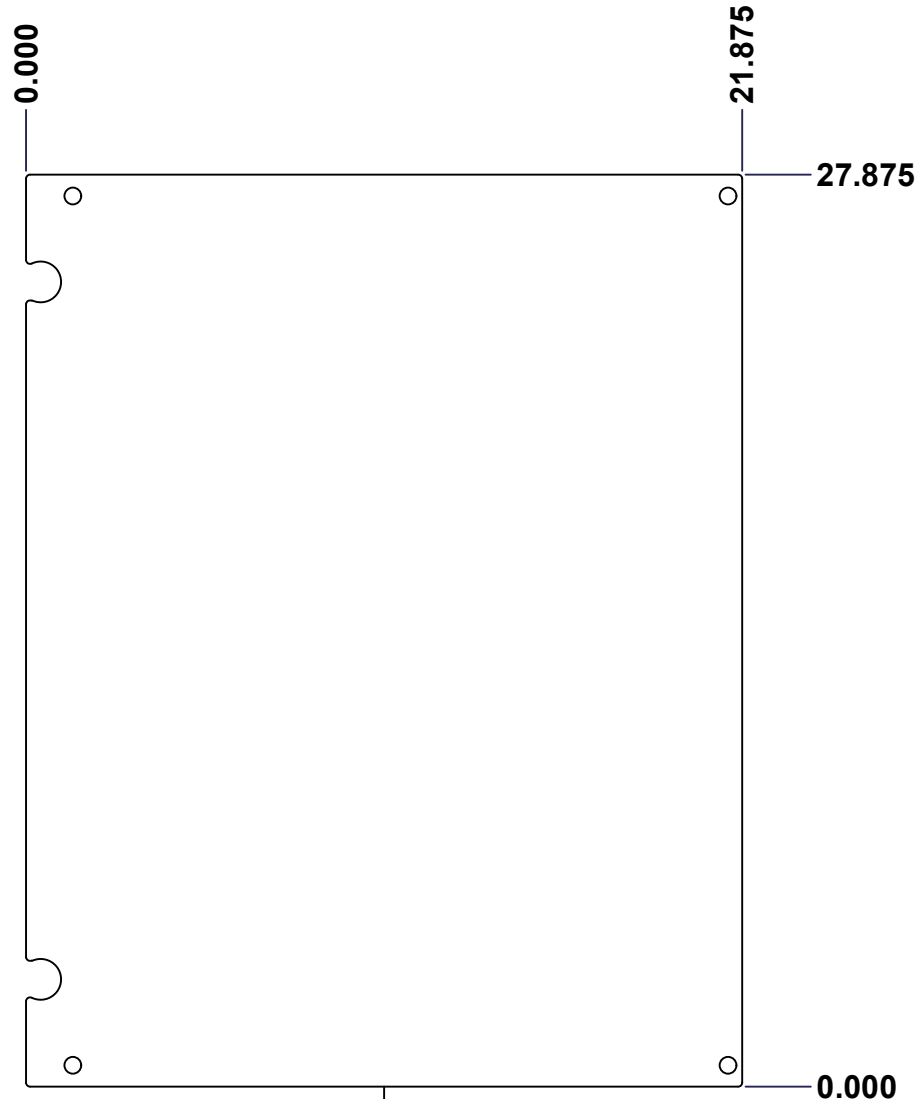

FRONT

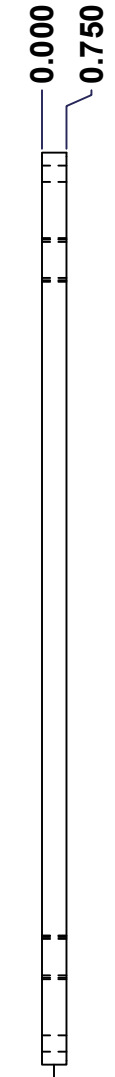

RIGHT

| No. | Revisions | Date | By/Par |
|-----|-----------|------|--------|
| | | | |
| | | | |
| | | | |
| | | | |

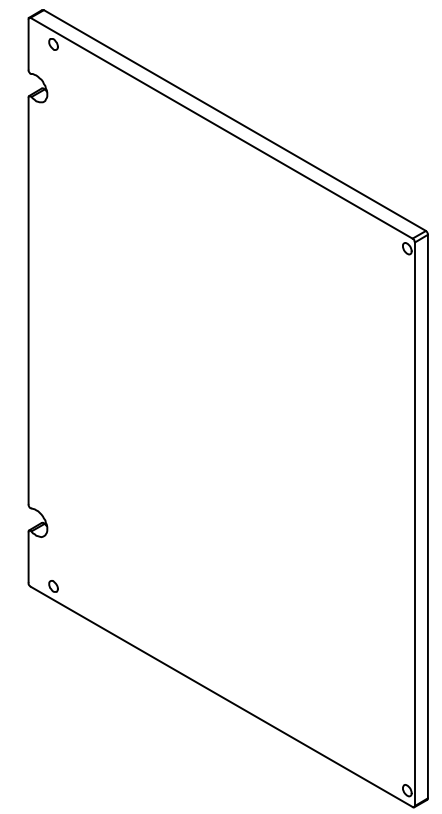

Isometric View



Tél: (450) 979-4373
 Fax: (450) 979-4626
www.exmweb.com

Flatness
Aplatissement
Max 3.0mm
Projection

| | |
|--|---------------------|
| Customer Client | Date |
| Drawn By Dessiné Par BoxCad: Patrick Deschenes | Date 23-Jan-07 |
| Material Matière Polyisocyanurate | |
| Color Couleur Aluminum | Finish Fini N/A |
| Description 5412ESFM 30" x 24" Cover Insulation | Detail Rev. |
| Part Number Numéro Pièce 5412ESFM302412THI-C | Rev. 19 0 |

SEE BILL OF MATERIAL ON LAST PAGE

This drawing is confidential and must not be reproduced or used without the consent of EXM

Ce dessin est confidentiel et ne doit pas être reproduit ou utilisé sans le consentement de EXM

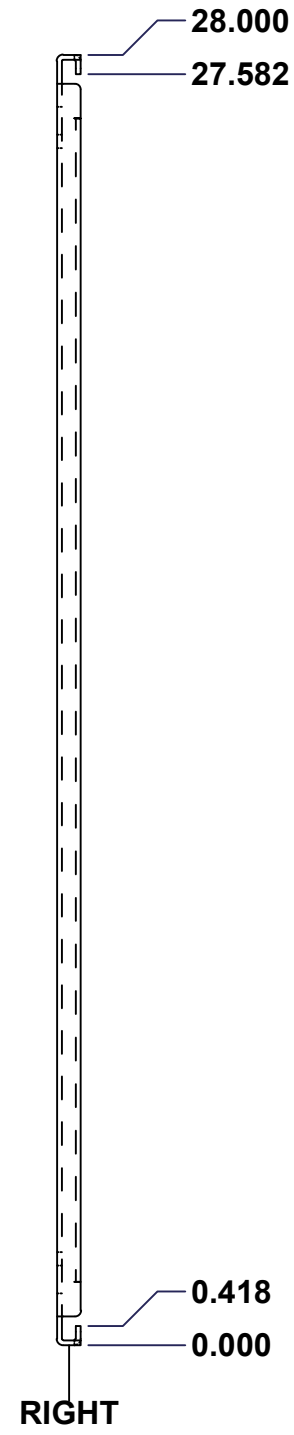
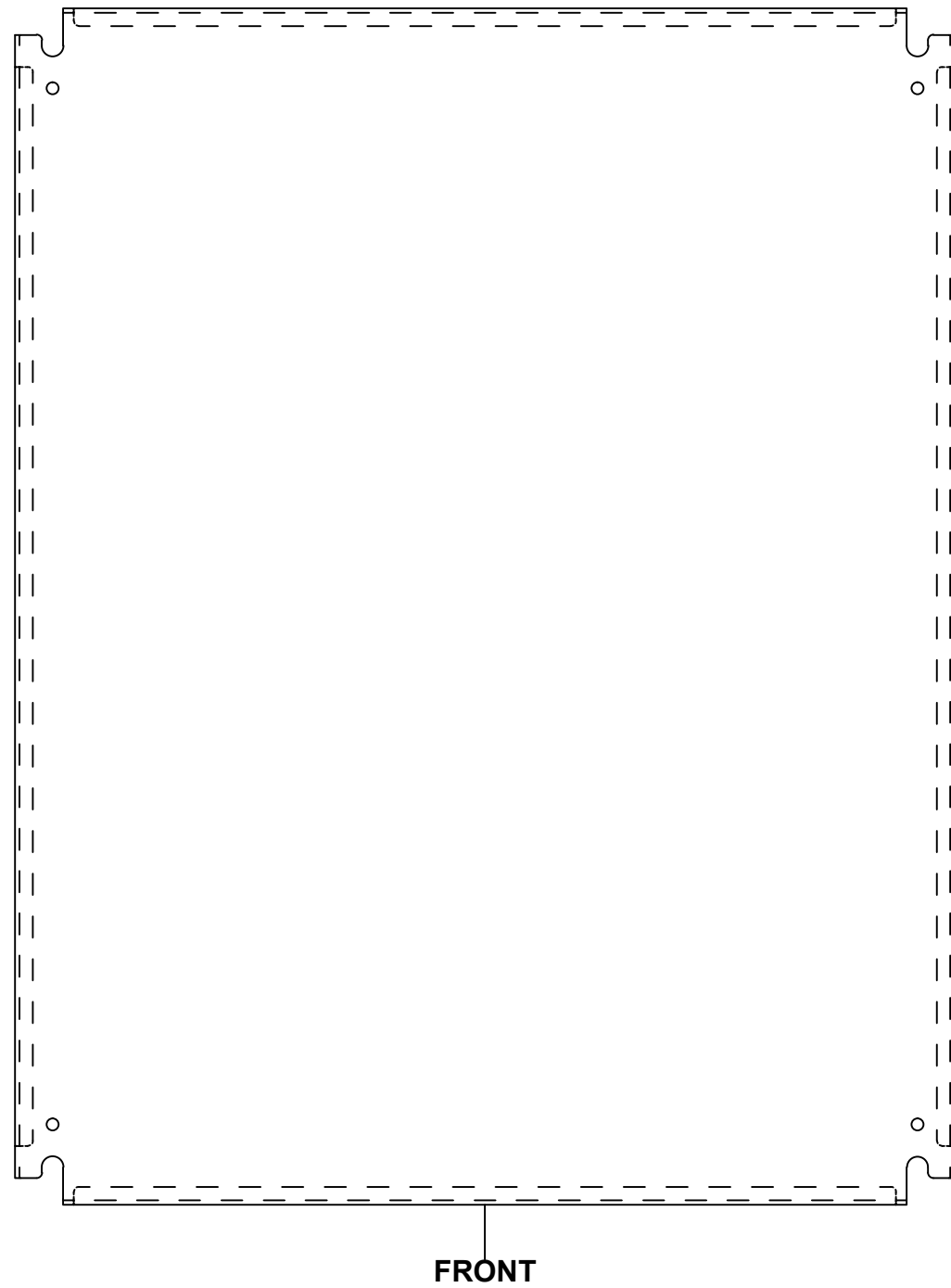
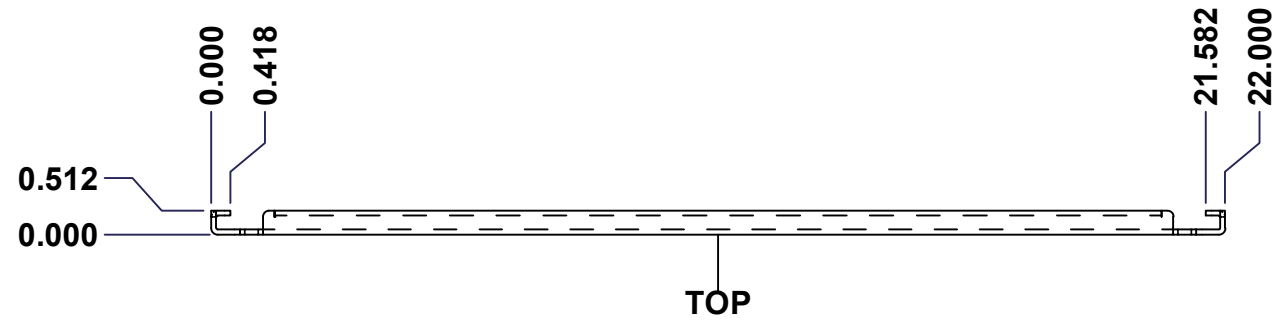

| No. | Revisions | Date | By/Par |
|-----|-----------|------|--------|
| | | | |
| | | | |
| | | | |
| | | | |
| | | | |

Isometric View

| | |
|---|---------------------------|
| <p>Tél: (450) 979-4373 Fax: (450) 979-4626 www.exmweb.com</p> | Flatness Aplatissement |
| | Max 3.0mm |
| Projection | |
| Customer Client | Date |
| Drawn By Dessiné Par BoxCad | Date 23-Jan-07 |
| Material Matière | See Part List |
| Color Couleur | See Part List |
| Finish Fini | See Part List |
| Description | Detail Rev. |
| 881 SP - Inner Panel | |
| Part Number Numéro Pièce | Rev. 1 |
| 881 SP3024G | 0 2 |

| Qty | Part Number | Rev | Description | Material | Color | Finish |
|-----|---------------|-----|---------------------------|------------------|-----------|------------|
| 1 | 881 SP3024G-P | 0 | 881 SP - Inner Panel Part | 12 Ga Galvanized | Unpainted | Galvanized |

Parts List

This drawing is confidential and must not be reproduced or used without the consent of EXM

Ce dessin est confidentiel et ne doit pas être reproduit ou utilisé sans le consentement de EXM

| Table 1 | | | FRONT VIEW |
|---------|--------|--------|--------------------------|
| CUT-OUT | XDIM | YDIM | DESCRIPTION |
| 1 | 0.875 | 1.875 | GROUND HOLE (RND Ø0.290) |
| 2 | 21.125 | 1.875 | GROUND HOLE (RND Ø0.290) |
| 3 | 0.875 | 26.125 | GROUND HOLE (RND Ø0.290) |
| 4 | 21.125 | 26.125 | GROUND HOLE (RND Ø0.290) |

All knockouts are actual size / Les disques défonçables sont grandeur réel

| No. | Revisions | Date | By/Par |
|-----|-----------|------|--------|
| | | | |
| | | | |
| | | | |
| | | | |
| | | | |

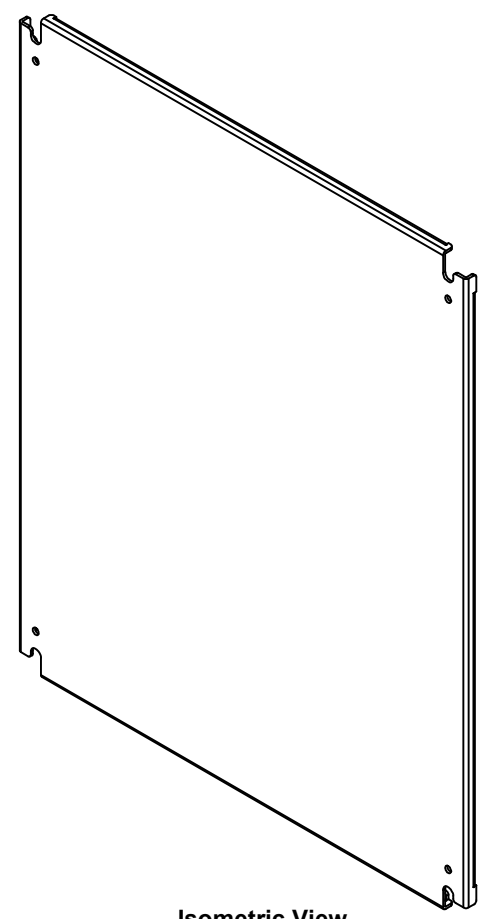
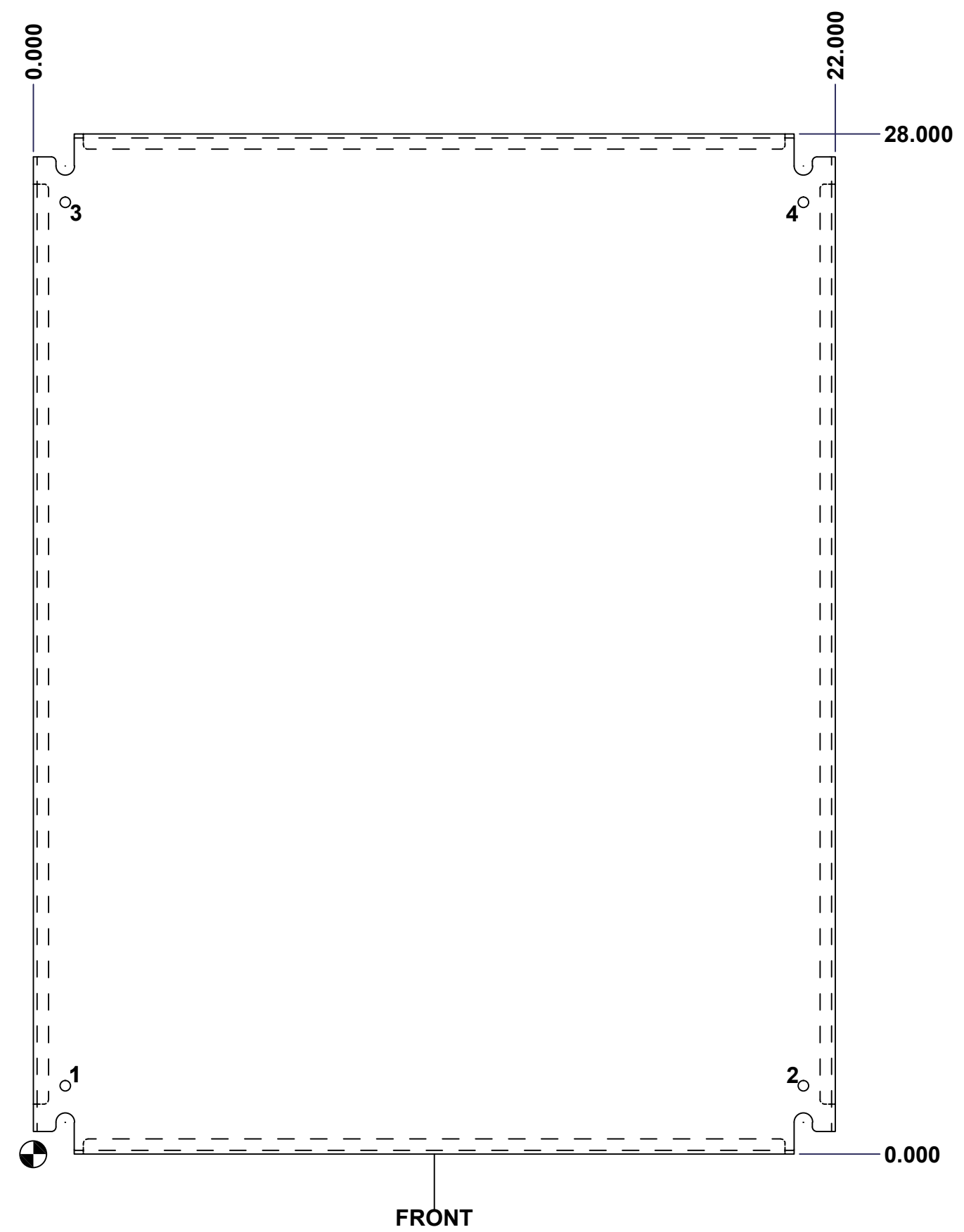

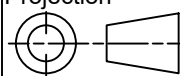
| | | |
|--|---------------|---|
|  Tél: (450) 979-4373 Fax: (450) 979-4626 www.exmweb.com | | Flatness Aplatissement Max 3.0mm Projection  |
| Customer Client | | Date |
| Drawn By Dessiné Par | BoxCad | Date 23-Jan-07 |
| Material Matière | See Part List | |
| Color Couleur | See Part List | Finish Fini See Part List |
| Description 881 SP - Inner Panel | | Detail Rev. |
| Part Number Numéro Pièce | 881 SP3024G | Rev. 2 0 |