

This drawing is confidential and must not be reproduced or used without the consent of EXM

Ce dessin est confidentiel et ne doit pas être reproduit ou utilisé sans le consentement de EXM

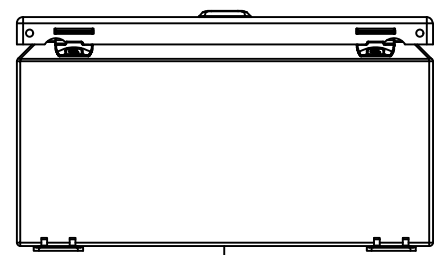

TOP

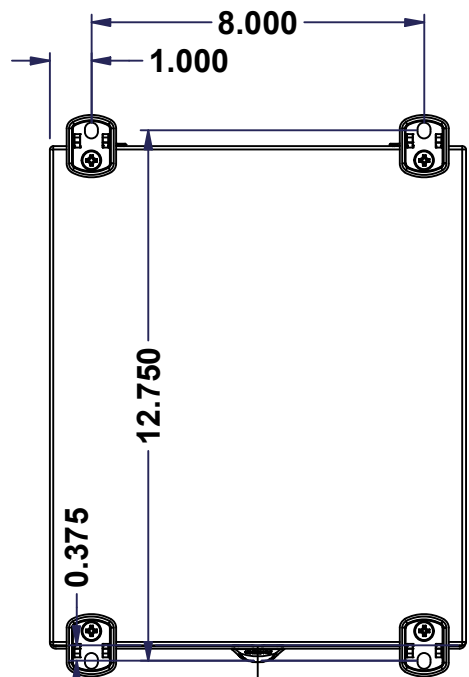

BACK

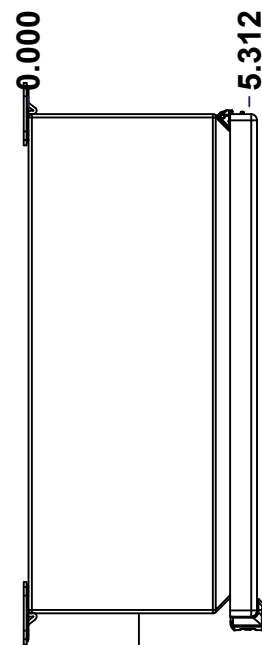

LEFT

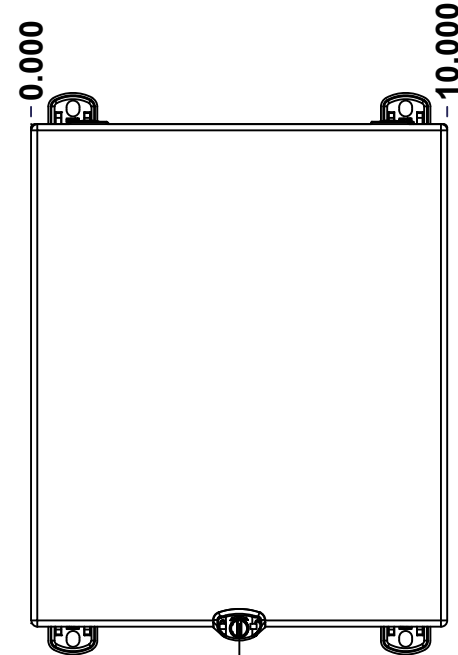

FRONT

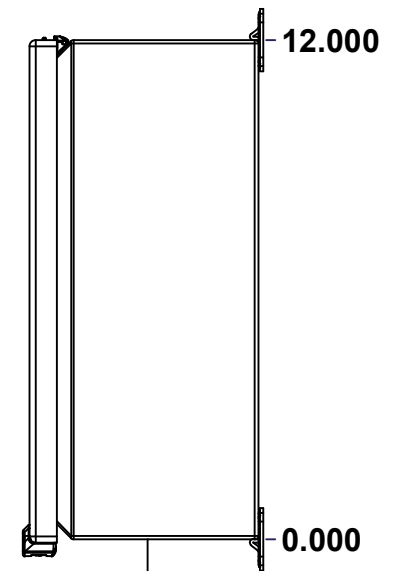

RIGHT

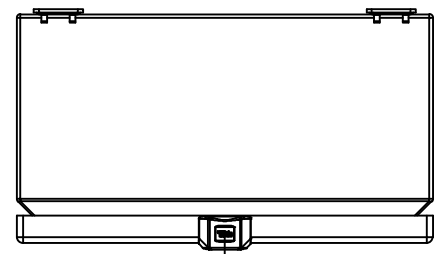

BOTTOM

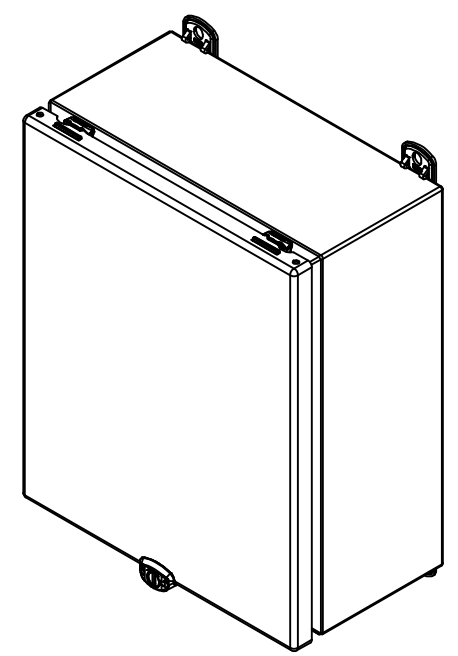

Isometric View

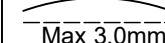
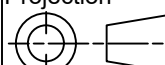

No.	Revisions	Date	By/Par

 Tél: (450) 979-4373 Fax: (450) 979-4626 www.exmweb.com		Flatness Aplatissement  Max 3.0mm Projection 
Customer Client	Date	
Drawn By Dessiné Par	BoxCad: patsan	Date 23-Oct-13
Material Matière	16 Ga Cold Rolled A1008 CS Type B (1.4mm)	
Color Couleur	Asa-61 Grey	Finish Fini Smooth
Description 5412ESLC 12" x 10" x 5" Assembly		Detail Rev.
Part Number Numéro Pièce	5412ESLC121005	Rev. 1 0

SEE BILL OF MATERIAL ON LAST PAGE

This drawing is confidential and must not be reproduced or used without the consent of EXM

Ce dessin est confidentiel et ne doit pas être reproduit ou utilisé sans le consentement de EXM

NOTE	
ITEM	DESCRIPTION
1	NEMA 4, 12 Enclosure (IP66)
2	C/W Standard ground standoffs on box and cover
3	W/O Standard door stiffener
4	C/W Standard inner panel (Included)
5	C/W Standard inner panel mounting standoffs
6	C/W 885 ESCHMF1 Mounting Feet (Kit)

No.	Revisions	Date	By/Par

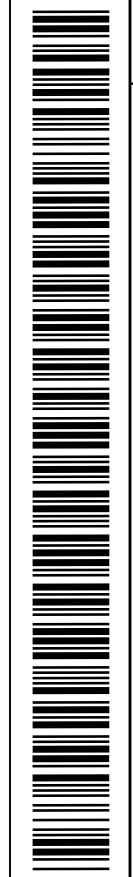
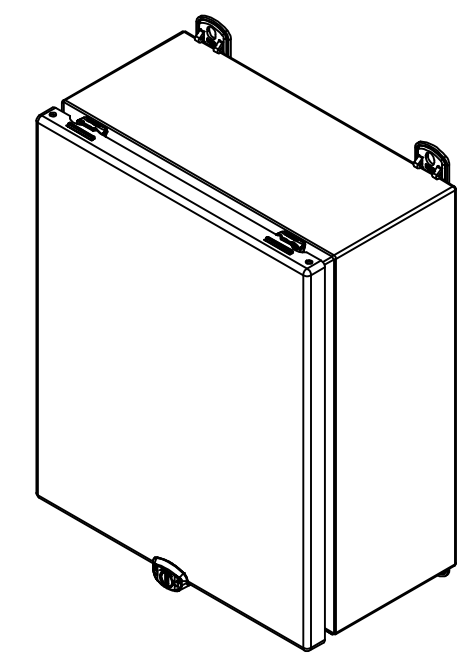

Isometric View



Tél: (450) 979-4373
 Fax: (450) 979-4626
www.exmweb.com

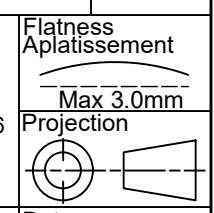

Customer Client	Date
Drawn By / Dessiné Par: BoxCad: patsan	Date: 23-Oct-13
Material / Matière: 16 Ga Cold Rolled A1008 CS Type B (1.4mm)	
Color / Couleur: Asa-61 Grey	Finish / Fini: Smooth

PACKING		
ITEM	QTY	DESCRIPTION
STK-E-04316	1	CARTON 5412 ESCH121005
Plastic bag	1	To protect cover surface and inside gasket
Packaging label	1	White label with product number
STK-S-01100	1	ESCH EXM SQUARE STICKER

Qty	Part Number	Rev	Description
1	5412ESLC121005C	0	5412ESLC 12" x 10" Cover
1	880 SP1210G	0	880 SP1210G - Inner Panel
1	STK-K-02930	0	5412 ESLC Accessory Kit
1	5412ESLC121005B	0	5412ESLC 12" x 10" x 5" Body
Parts List			

Description: 5412ESLC 12" x 10" x 5" Assembly	Detail Rev.
Part Number / Numéro Pièce: 5412ESLC121005	Rev. 0
	2 / 9

This drawing is confidential and must not be reproduced or used without the consent of EXM

Ce dessin est confidentiel et ne doit pas être reproduit ou utilisé sans le consentement de EXM

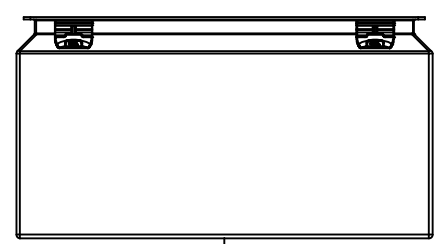

TOP

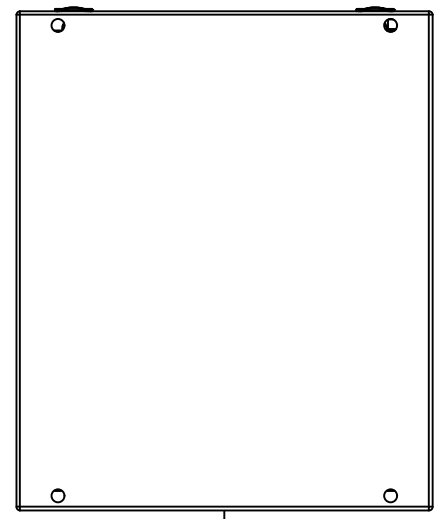

BACK

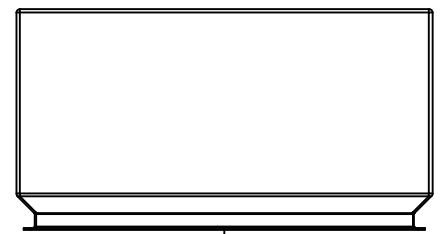

BOTTOM

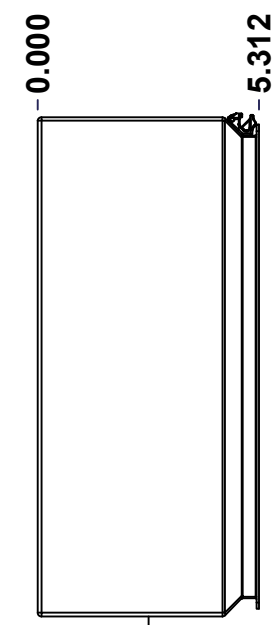

LEFT

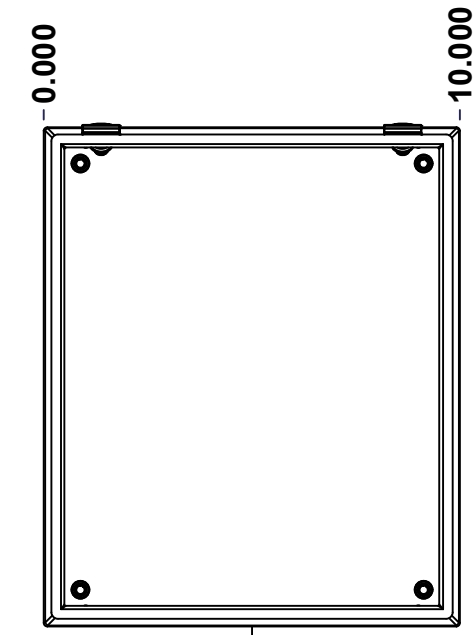

FRONT

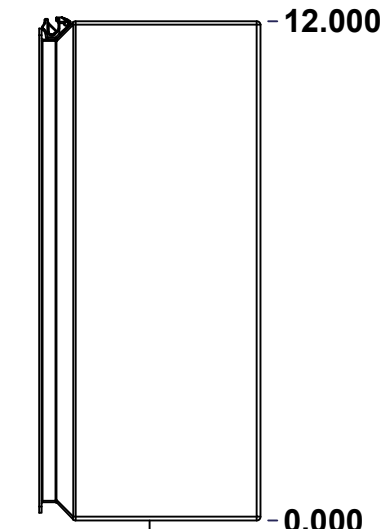

RIGHT

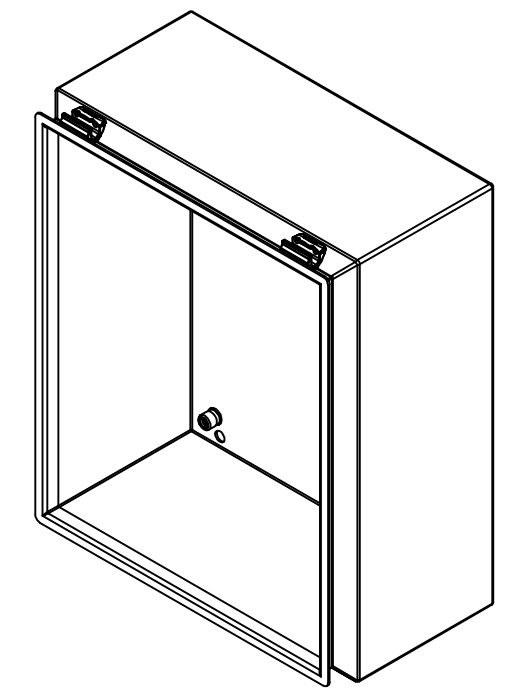

Isometric View

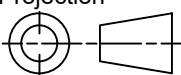

No.	Revisions	Date	By/Par

 Tél: (450) 979-4373 Fax: (450) 979-4626 www.exmweb.com		Flatness Aplatissement Max 3.0mm Projection 
Customer Client	Date	
Drawn By Dessiné Par	BoxCad: patsan	Date 23-Oct-13
Material Matière	16 Ga Cold Rolled A1008 CS Type B (1.4mm)	
Color Couleur	Asa-61 Grey	Finish Fini Smooth
Description	Detail Rev.	
5412ESLC 12" x 10" x 5" Body		
Part Number Numéro Pièce	Rev.	3
5412ESLC121005B	0	9

SEE BILL OF MATERIAL ON LAST PAGE

This drawing is confidential and must not be reproduced or used without the consent of EXM

Ce dessin est confidentiel et ne doit pas être reproduit ou utilisé sans le consentement de EXM

STANDARD FEATURES ARE NOT LISTED IN THIS HOLE TABLE			
HOLE TABLE - TOP VIEW (CUSTOM FEATURE ONLY)			
CUT-OUT	XDIM	YDIM	DESCRIPTION
1	0.875	3.625	STANDOFF M6 x 10mm (Inside)

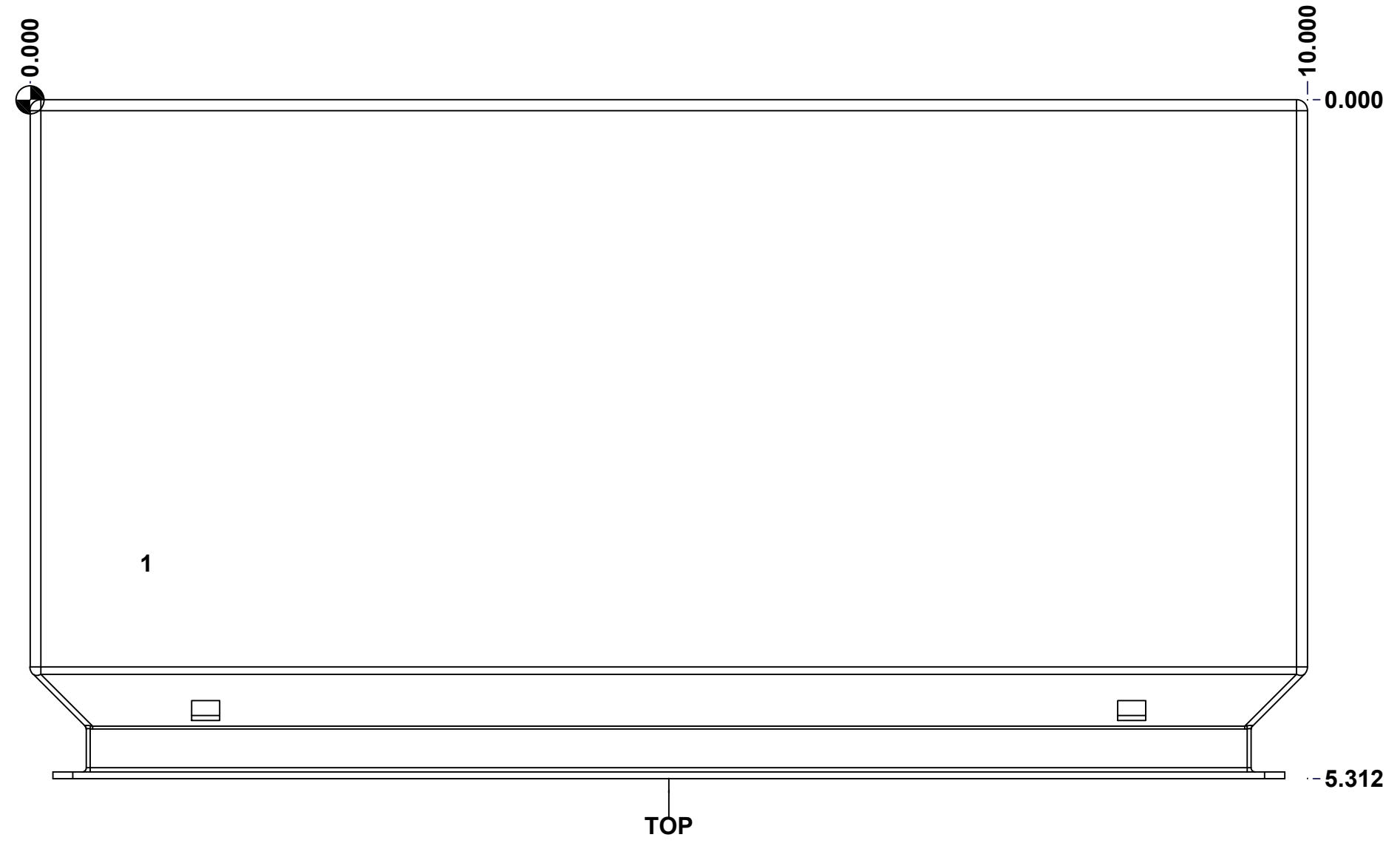

	Description	Status	
	5412ESLC 12" x 10" x 5" Body	(NULL)	
	Part Number Numéro Pièce	Rev.	4
	5412ESLC121005B	0	9

This drawing is confidential and must not be reproduced or used without the consent of EXM

Ce dessin est confidentiel et ne doit pas être reproduit ou utilisé sans le consentement de EXM

STANDARD FEATURES ARE NOT LISTED IN THIS HOLE TABLE

HOLE TABLE - BACK VIEW (CUSTOM FEATURE ONLY)

CUT-OUT	XDIM	YDIM	DESCRIPTION
1	0.875	0.875	IP STANDOFF M6 x 10mm (Inside)
2	0.875	11.125	IP STANDOFF M6 x 10mm (Inside)
3	9.125	11.125	IP STANDOFF M6 x 10mm (Inside)
4	9.125	0.875	IP STANDOFF M6 x 10mm (Inside)

5	9.000	0.000	FOOT 885 ESCHMF1
6	1.000	0.000	FOOT 885 ESCHMF1
7	9.000	12.000	FOOT 885 ESCHMF1
8	1.000	12.000	FOOT 885 ESCHMF1

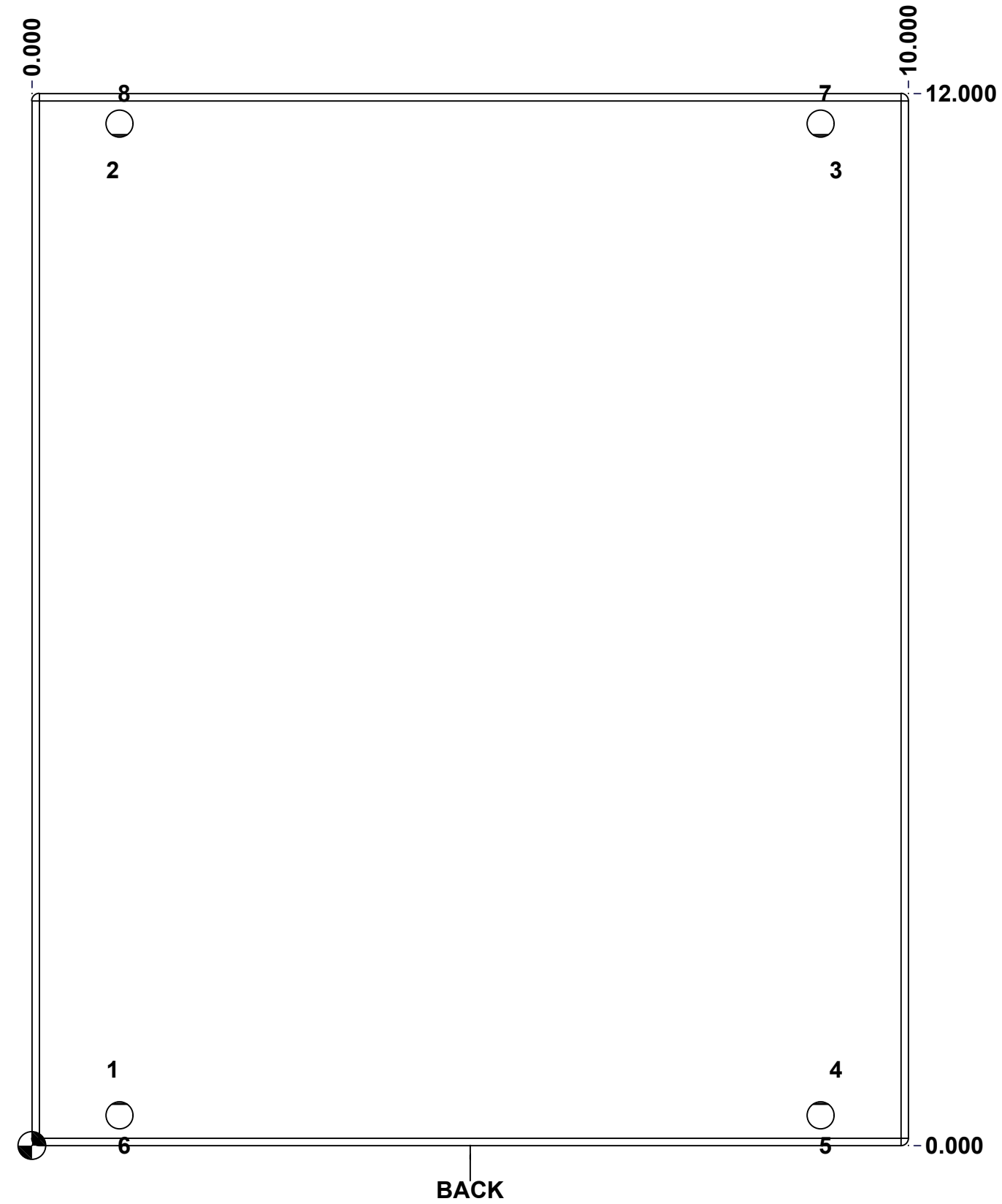

	Description	Status
	5412ESLC 12" x 10" x 5" Body	(NULL)
Part Number Numéro Pièce 5412ESLC121005B	Rev.	5
	0	9

This drawing is confidential and must not be reproduced or used without the consent of EXM

Ce dessin est confidentiel et ne doit pas être reproduit ou utilisé sans le consentement de EXM

No.	Revisions	Date	By/Par

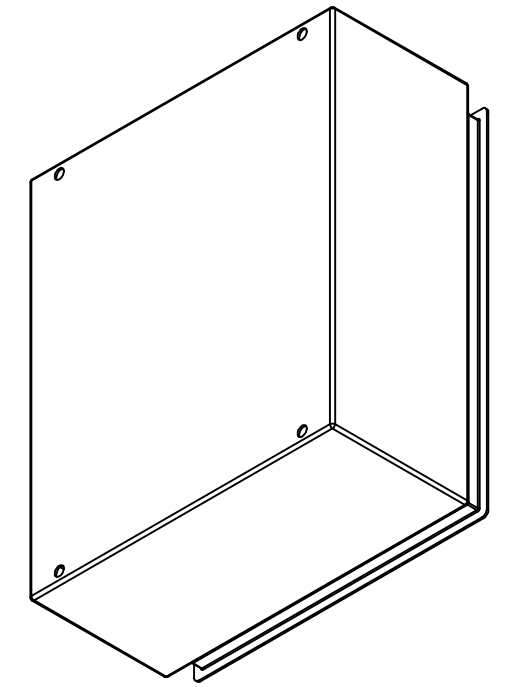

Isometric View

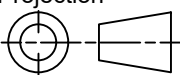

 Tél: (450) 979-4373 Fax: (450) 979-4626 www.exmweb.com	Flatness Aplatissement	Max 3.0mm
	Projection	
Customer Client	Date	
Drawn By Dessiné Par	BoxCad: patsan	Date 23-Oct-13
Material Matière	16 Ga Cold Rolled A1008 CS Type B (1.4mm)	
Color Couleur	Asa-61 Grey	Finish Fini Smooth
Description	Detail Rev.	
5412ESLC 12" x 10" x 5" Body		
Part Number Numéro Pièce	Rev.	6
5412ESLC121005B	0	9

Qty	Part Number	Rev	Description
1	STK-P-02400S	0	Powder Paint (Asa-61 Grey / Smooth)
1	5412ESLC121005B-P	0	5412ESLC 12" x 10" x 5" Body Part
2	STK-Q-08126	1	M5 Stainless Steel 316 Nylon Insert Lock Nut with Incorporated Sealing Washer
5	STK-Q-08350	5	Standoff M6 x 10mm
2	STK-Q-70476	0	5412ESMLC - Zinc Casting Body Catch
Parts List			

This drawing is confidential and must not be reproduced or used without the consent of EXM

Ce dessin est confidentiel et ne doit pas être reproduit ou utilisé sans le consentement de EXM



TOP

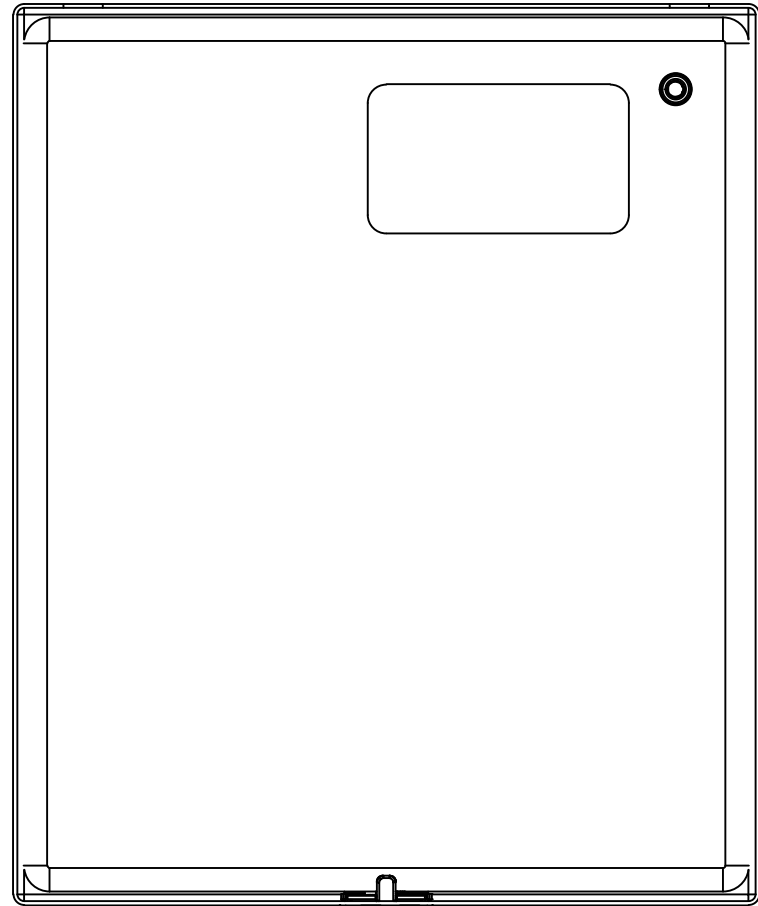

BACK



BOTTOM

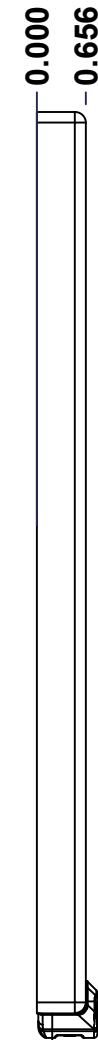

LEFT

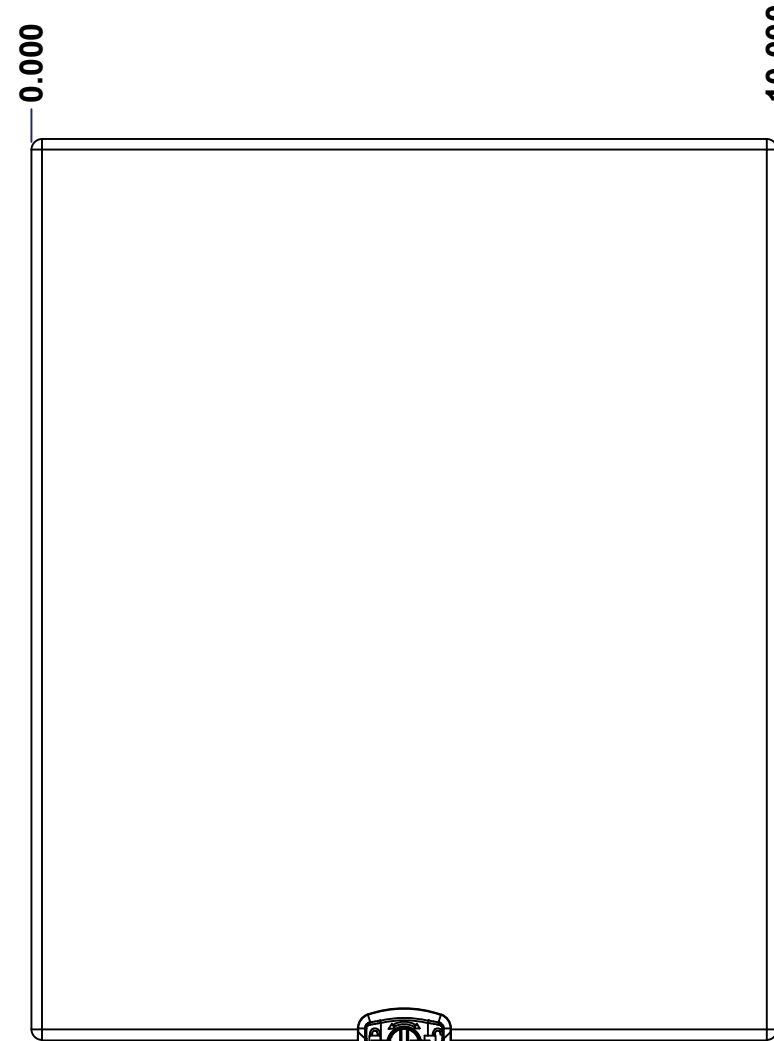

FRONT

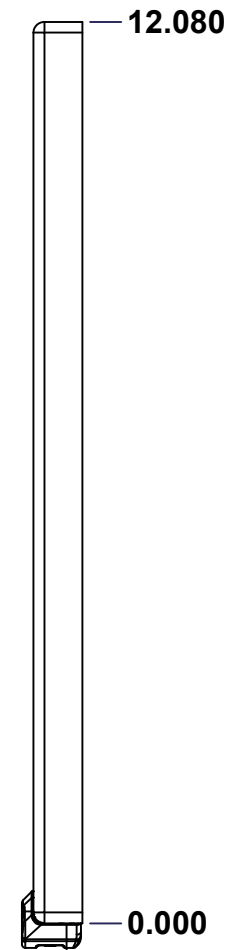

RIGHT

No.	Revisions	Date	By/Par

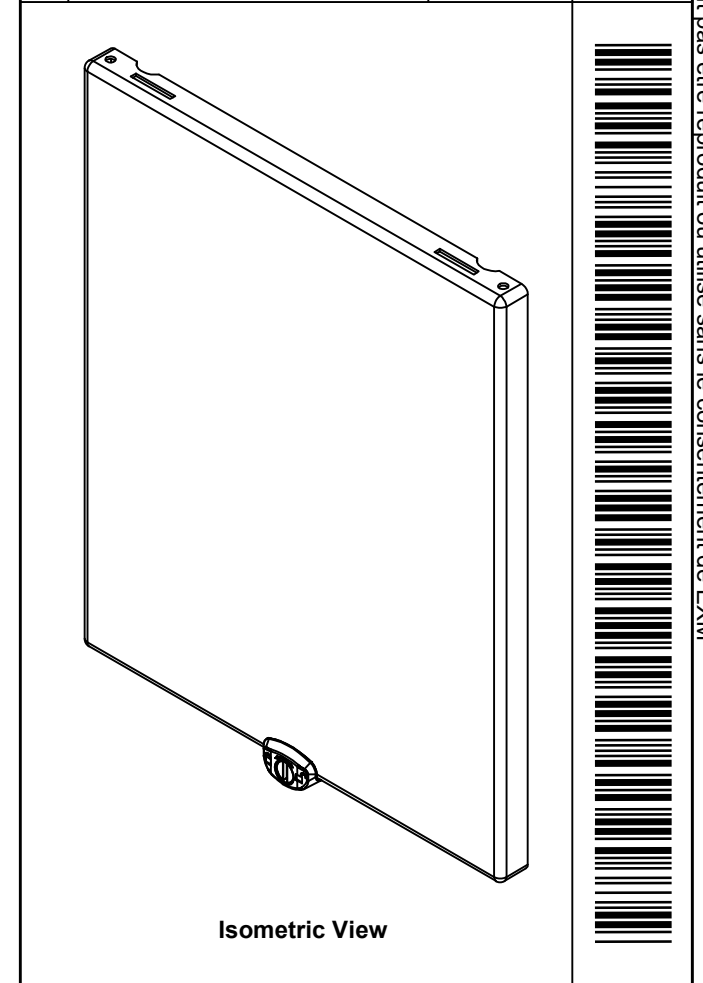

Isometric View

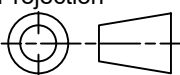
 Tél: (450) 979-4373 Fax: (450) 979-4626 www.exmweb.com		Flatness Aplatissement Max 3.0mm Projection 
Customer Client	Date	
Drawn By Dessiné Par	BoxCad: patsan	Date 23-Oct-13
Material Matière	16 Ga Cold Rolled A1008 CS Type B (1.4mm)	
Color Couleur	Asa-61 Grey	Finish Fini Smooth
Description		Detail Rev.
5412ESLC 12" x 10" Cover		
Part Number Numéro Pièce	Rev.	7
5412ESLC121005C	0	9

SEE BILL OF MATERIAL ON LAST PAGE

This drawing is confidential and must not be reproduced or used without the consent of EXM

Ce dessin est confidentiel et ne doit pas être reproduit ou utilisé sans le consentement de EXM

STANDARD FEATURES ARE NOT LISTED IN THIS HOLE TABLE			
HOLE TABLE - FRONT VIEW (CUSTOM FEATURE ONLY)			
CUT-OUT	XDIM	YDIM	DESCRIPTION
1	1.125	10.935	STANDOFF M6 x 10mm (Inside)
2	3.500	10.000	LABEL_EXM
3	5.000	0.000	LOCK 880 SCQ2MS @ 270.0°

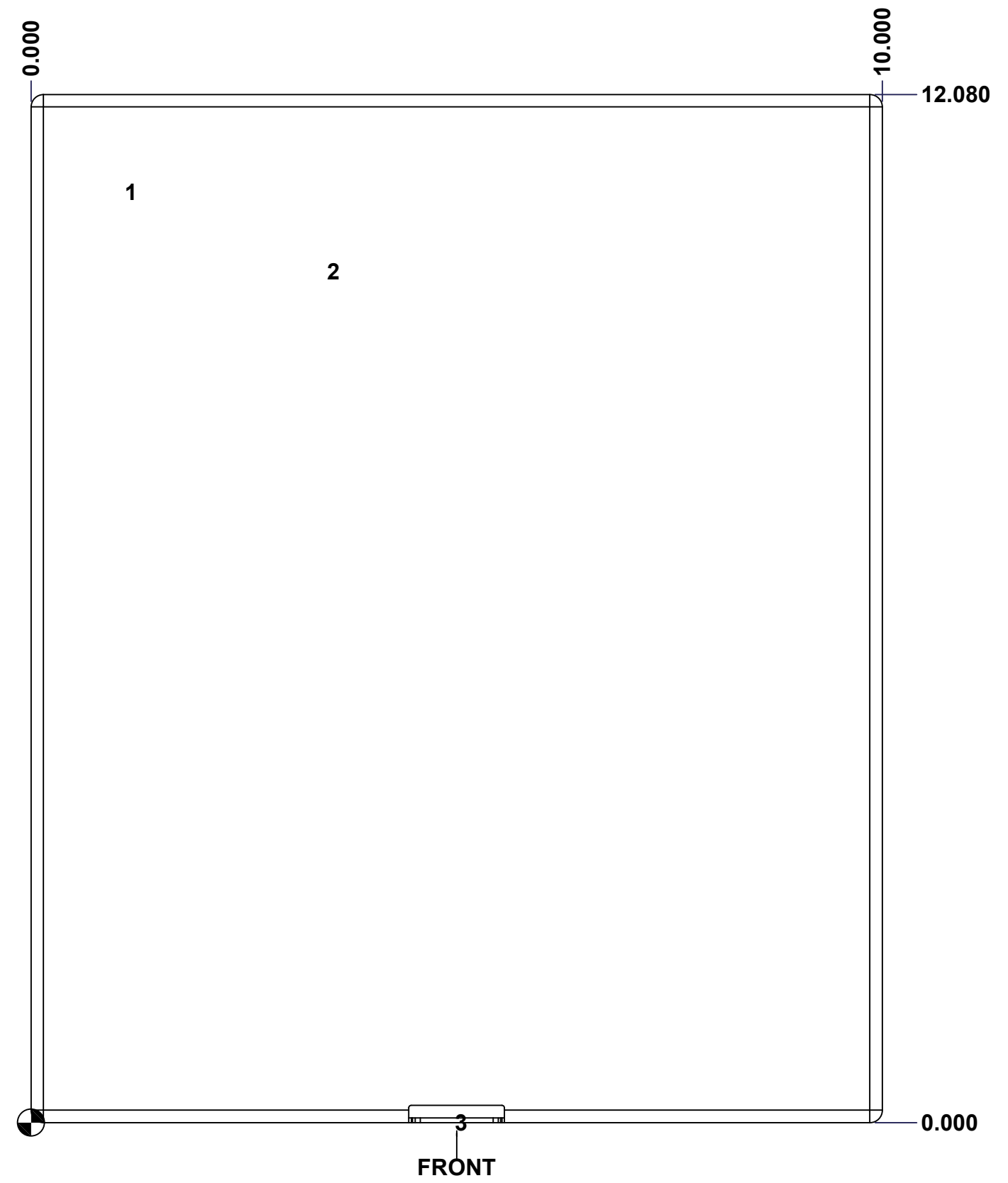



	Description	Status	
	5412ESLC 12" x 10" Cover	(NULL)	
	Part Number Numéro Pièce	Rev.	
	5412ESLC121005C	0	8 9

This drawing is confidential and must not be reproduced or used without the consent of EXM

Ce dessin est confidentiel et ne doit pas être reproduit ou utilisé sans le consentement de EXM

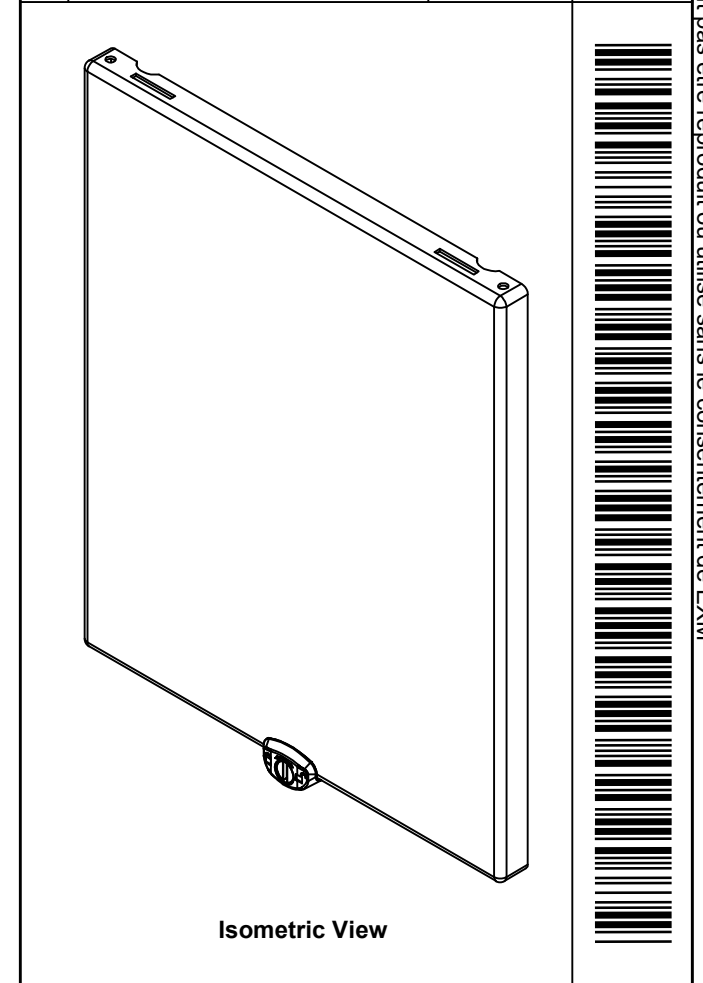
No.	Revisions	Date	By/Par

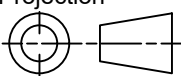

 Tél: (450) 979-4373 Fax: (450) 979-4626 www.exmweb.com		Flatness Aplatissement Max 3.0mm Projection 
Customer Client	Date	
Drawn By Dessiné Par	BoxCad: patsan	Date 23-Oct-13
Material Matière	16 Ga Cold Rolled A1008 CS Type B (1.4mm)	
Color Couleur	Asa-61 Grey	Finish Fini Smooth
Description		Detail Rev.
5412ESLC 12" x 10" Cover		
Part Number Numéro Pièce	Rev.	9
5412ESLC121005C	0	9

Qty	Part Number	Rev	Description
1	STK-Q-08350	5	Standoff M6 x 10mm
1	STK-P-02400S	0	Powder Paint (Asa-61 Grey / Smooth)
1	5412ESLC121005G	0	5412ESLC 12" x 10" Gasket
1	880SCQ2S	4	5412 ESMCH - External Lock Assy - Slot Lock
1	STK-S-00100	0	3.5" x 2" Silver Milar Flexcon Sticker
1	5412ESLC121005C-P	0	5412ESLC 12" x 10" Cover Part
Parts List			

This drawing is confidential and must not be reproduced or used without the consent of EXM

Ce dessin est confidentiel et ne doit pas être reproduit ou utilisé sans le consentement de EXM

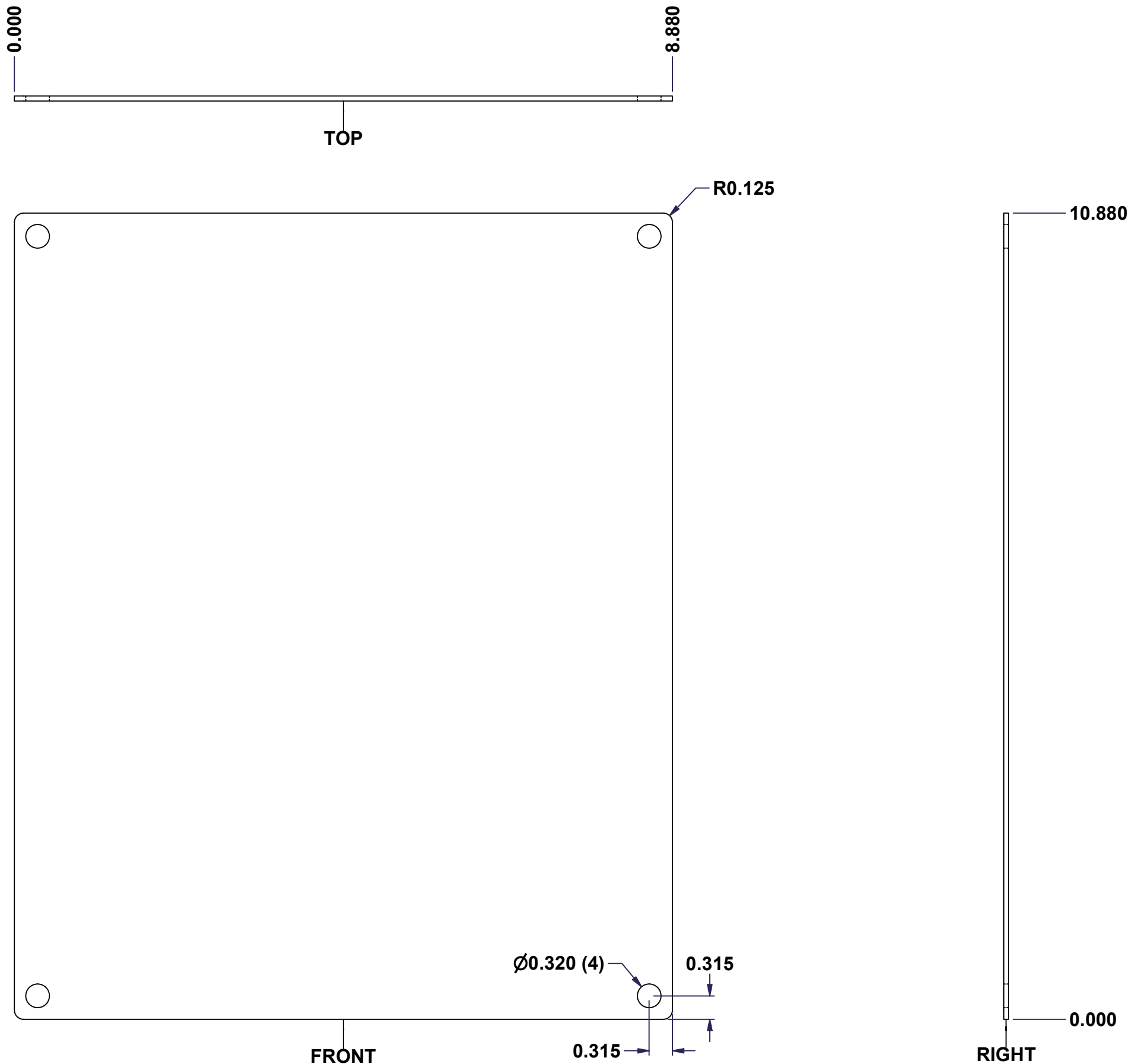

No.	Revisions	Date	By/Par

Isometric View

<p>Tél: (450) 979-4373 Fax: (450) 979-4626 www.exmweb.com</p>	Flatness Aplatissement	Max 3.0mm
	Projection	
Customer Client	Date	
Drawn By Dessiné Par BoxCad	Date	23-Jan-07
Material Matière	14 Ga Galvanized (1.7mm)	
Color Couleur Unpainted	Finish Fini Galvanized	
Description	880 SP1210G - Inner Panel	
Part Number Numéro Pièce	Rev.	1 2
880 SP1210G		0

SEE BILL OF MATERIAL ON LAST PAGE

This drawing is confidential and must not be reproduced or used without the consent of EXM

Ce dessin est confidentiel et ne doit pas être reproduit ou utilisé sans le consentement de EXM

No.	Revisions	Date	By/Par

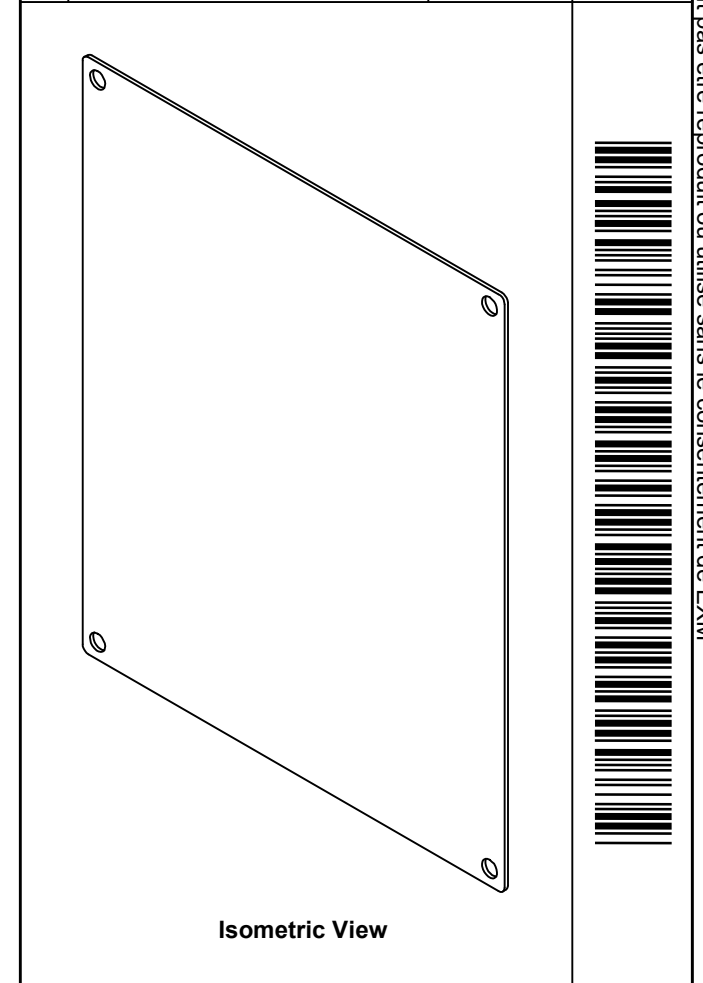

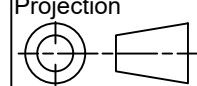
 Tél: (450) 979-4373 Fax: (450) 979-4626 www.exmweb.com		Flatness Aplatissement Max 3.0mm
Customer Client		Projection 
Drawn By Dessiné Par BoxCad		Date 23-Jan-07
Material Matière 14 Ga Galvanized (1.7mm)		
Color Couleur Unpainted	Finish Fini Galvanized	
Description 880 SP1210G - Inner Panel		Detail Rev.
Part Number Numéro Pièce 880 SP1210G	Rev. 0	2 2

Qty	Part Number	Rev	Description
1	880 SP1210G-P	0	880 SP1210G - Inner Panel Part
Parts List			