

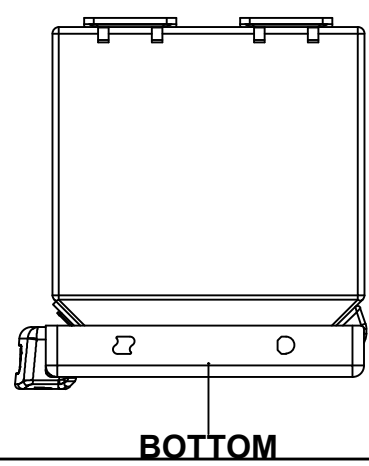

This drawing is confidential and must not be reproduced or used without the consent of EXM

Ce dessin est confidentiel et ne doit pas être reproduit ou utilisé sans le consentement de EXM

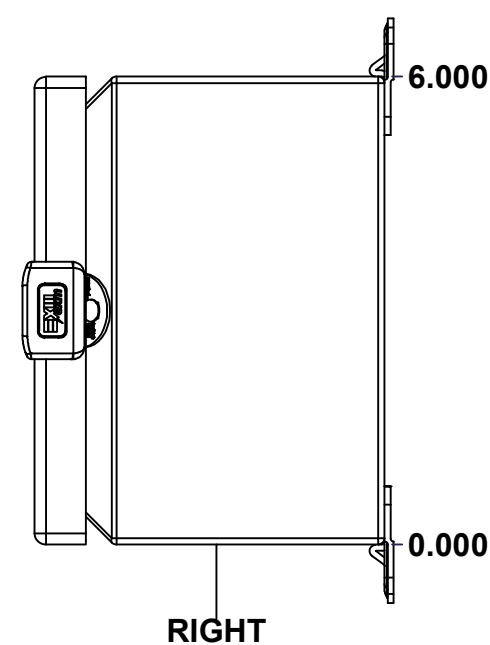
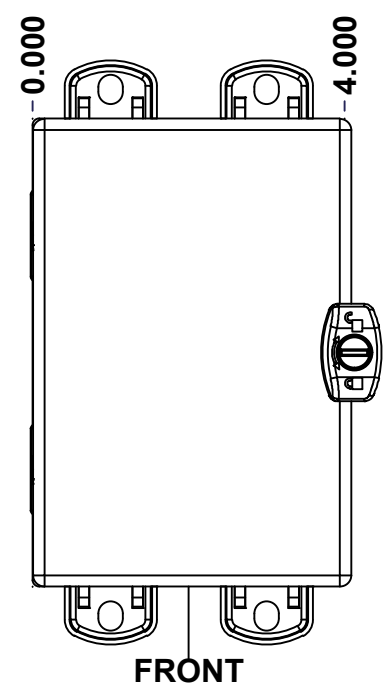
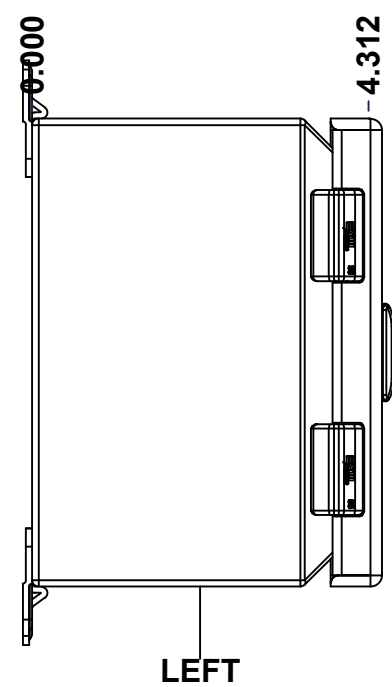
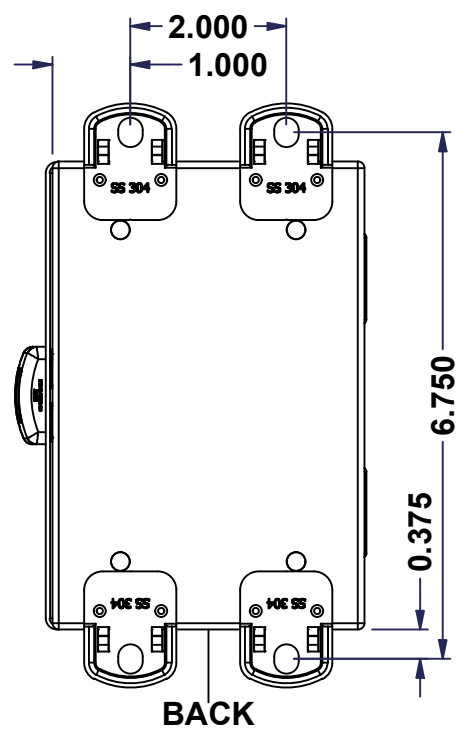
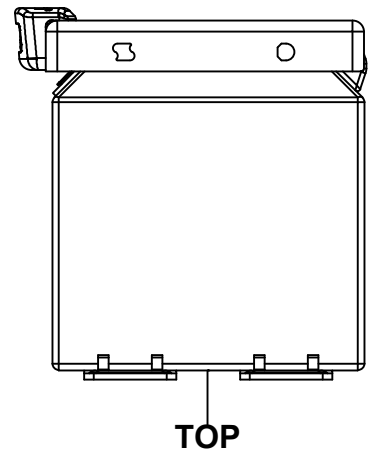
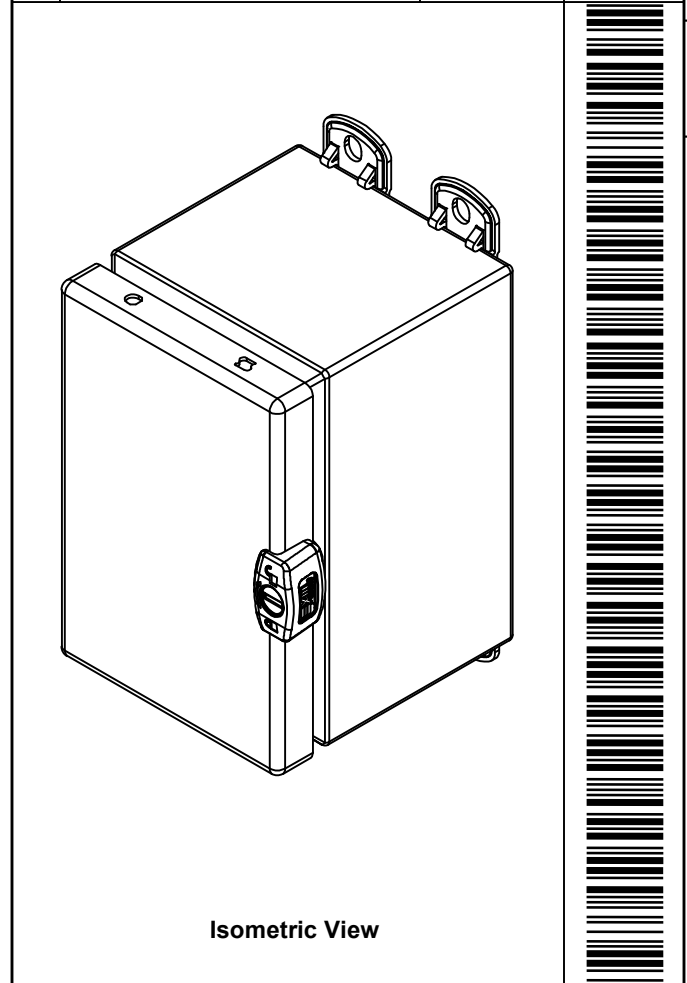

No.	Revisions	Date	By/Par



 Tél: (450) 979-4373 Fax: (450) 979-4626 www.exmweb.com		Flatness Aplatissement	
		Max 3.0mm	
Customer Client		Date	
Drawn By Dessiné Par BoxCad: BoxCad		Date 23-Nov-14	
Material Matière 16 Ga Stainless Steel 304 (1.4mm)		Projection	
Color Couleur Asa-61 Grey		Finish Fini Smooth	
Description 5412ESSMPCH 6" x 4" x 4" Assembly			Detail Rev.
Part Number Numéro Pièce 5412ESSMPCH060404		Rev. 0	1 / 10

SEE BILL OF MATERIAL ON LAST PAGE

This drawing is confidential and must not be reproduced or used without the consent of EXM

Ce dessin est confidentiel et ne doit pas être reproduit ou utilisé sans le consentement de EXM

NOTE	
ITEM	DESCRIPTION
1	NEMA 4X Enclosure
2	C/W Standard ground standoffs on box and cover
3	W/O Standard door stiffener
4	C/W Standard inner panel (Included)
5	C/W Standard inner panel mounting standoffs
6	C/W 885 ESCHMF2 Mounting Feet (Welded)

No.	Revisions	Date	By/Par

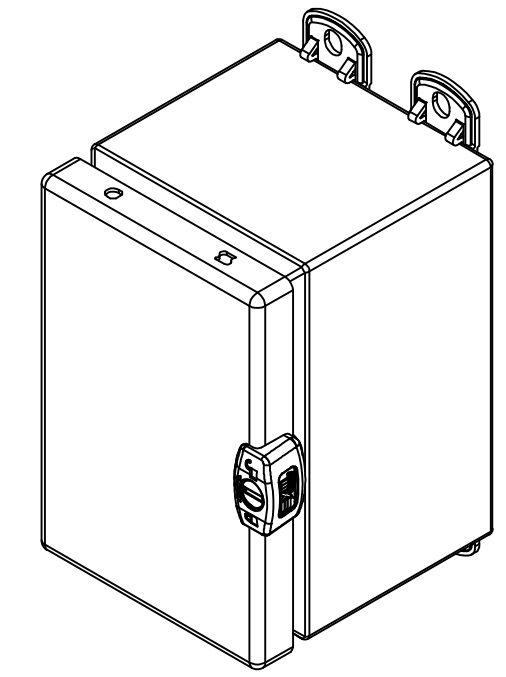

Isometric View



	Tél: (450) 979-4373 Fax: (450) 979-4626 www.exmweb.com	Flatness Aplatissement Max 3.0mm Projection
	Customer Client	Date
Drawn By Dessiné Par	BoxCad: BoxCad	Date 23-Nov-14
Material Matière	16 Ga Stainless Steel 304 (1.4mm)	
Color Couleur	Asa-61 Grey	Finish Fini Smooth
Description 5412ESSMPCH 6" x 4" x 4" Assembly	Detail Rev.	
Part Number Numéro Pièce 5412ESSMPCH060404	Rev. 0	2 / 10

Qty	Part Number	Rev	Description
1	5412ESSMPCH060404C	0	5412ESSMPCH 6" x 4" Cover
1	STK-K-02910	3	5412 ESCH Accessory Kit
8	STK-Q-07200	0	Flange Lock Nut
1	880 SP0604G	0	880 SP0604G - Inner Panel
1	5412ESSMPCH060404B	0	5412ESSMPCH 6" x 4" x 4" Body
2	STK-Q-08100	1	M5 Nylon Insert Lock Nut
2	STK-Q-10249	0	M5 Sealing Washer
Parts List			

PACKING		
ITEM	QTY	DESCRIPTION
STK-E-04302	1	CARTON 5412 ESCH060404
Plastic bag	1	To protect cover surface and inside gasket
Packaging label	1	White label with product number
STK-S-01100	1	ESCH EXM SQUARE STICKER

This drawing is confidential and must not be reproduced or used without the consent of EXM

Ce dessin est confidentiel et ne doit pas être reproduit ou utilisé sans le consentement de EXM

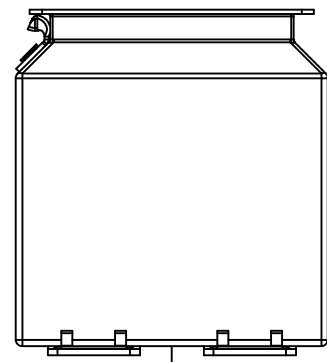

TOP

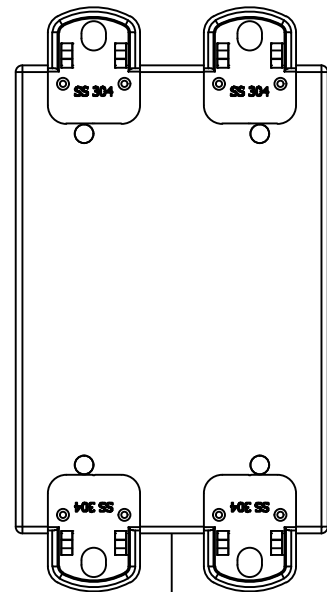

BACK

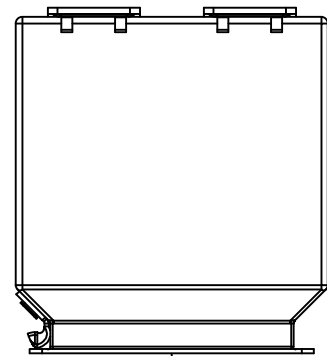

BOTTOM

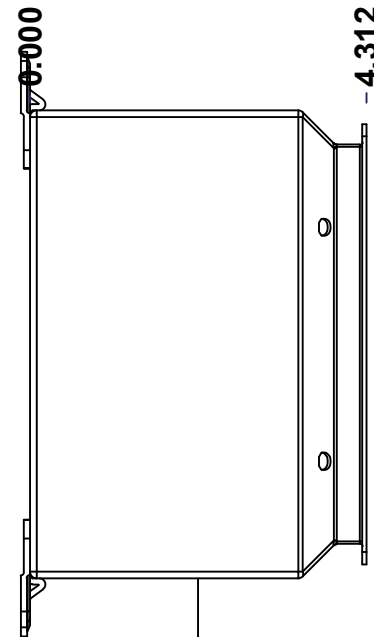

LEFT

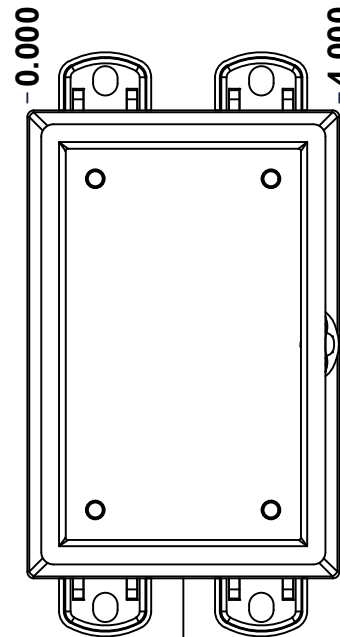

FRONT

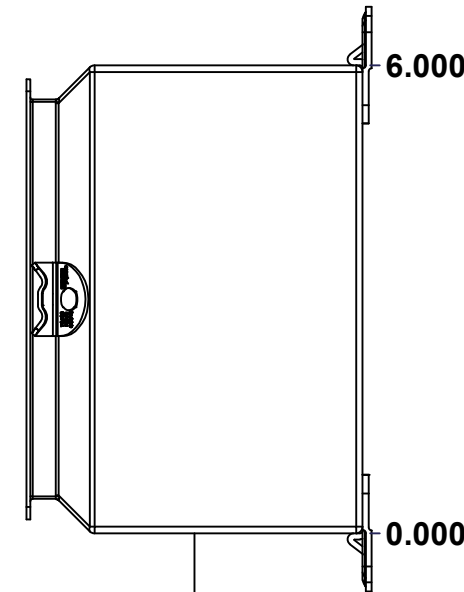

RIGHT

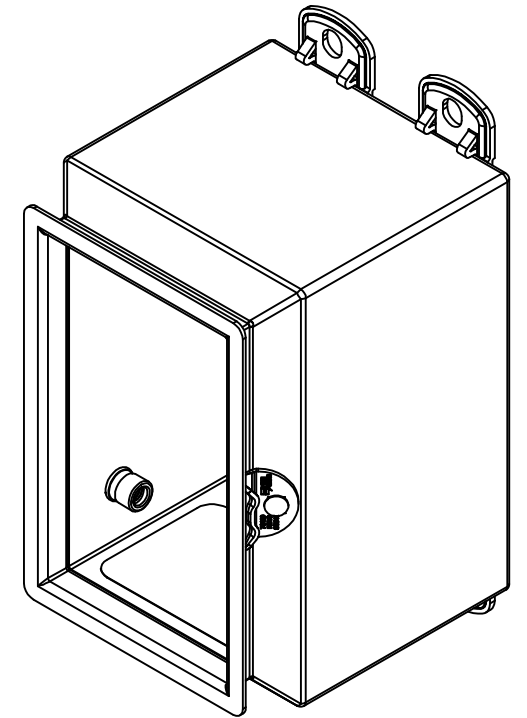

Isometric View



No.	Revisions	Date	By/Par

	Flatness Aplatissement Max 3.0mm
	Projection
Tél: (450) 979-4373 Fax: (450) 979-4626 www.exmweb.com	Customer Client Date
Drawn By Dessiné Par BoxCad: BoxCad	Date 23-Nov-14
Material Matière 16 Ga Stainless Steel 304 (1.4mm)	Description 5412ESSMPCH 6" x 4" x 4" Body
Color Couleur Asa-61 Grey	Finish Fini Smooth
Part Number Numéro Pièce 5412ESSMPCH060404B	Detail Rev. Rev. 3 0

SEE BILL OF MATERIAL ON LAST PAGE

This drawing is confidential and must not be reproduced or used without the consent of EXM

Ce dessin est confidentiel et ne doit pas être reproduit ou utilisé sans le consentement de EXM

STANDARD FEATURES ARE NOT LISTED IN THIS HOLE TABLE			
HOLE TABLE - BOTTOM VIEW (CUSTOM FEATURE ONLY)			
CUT-OUT	XDIM	YDIM	DESCRIPTION
1	2.000	2.250	LABEL_EXM

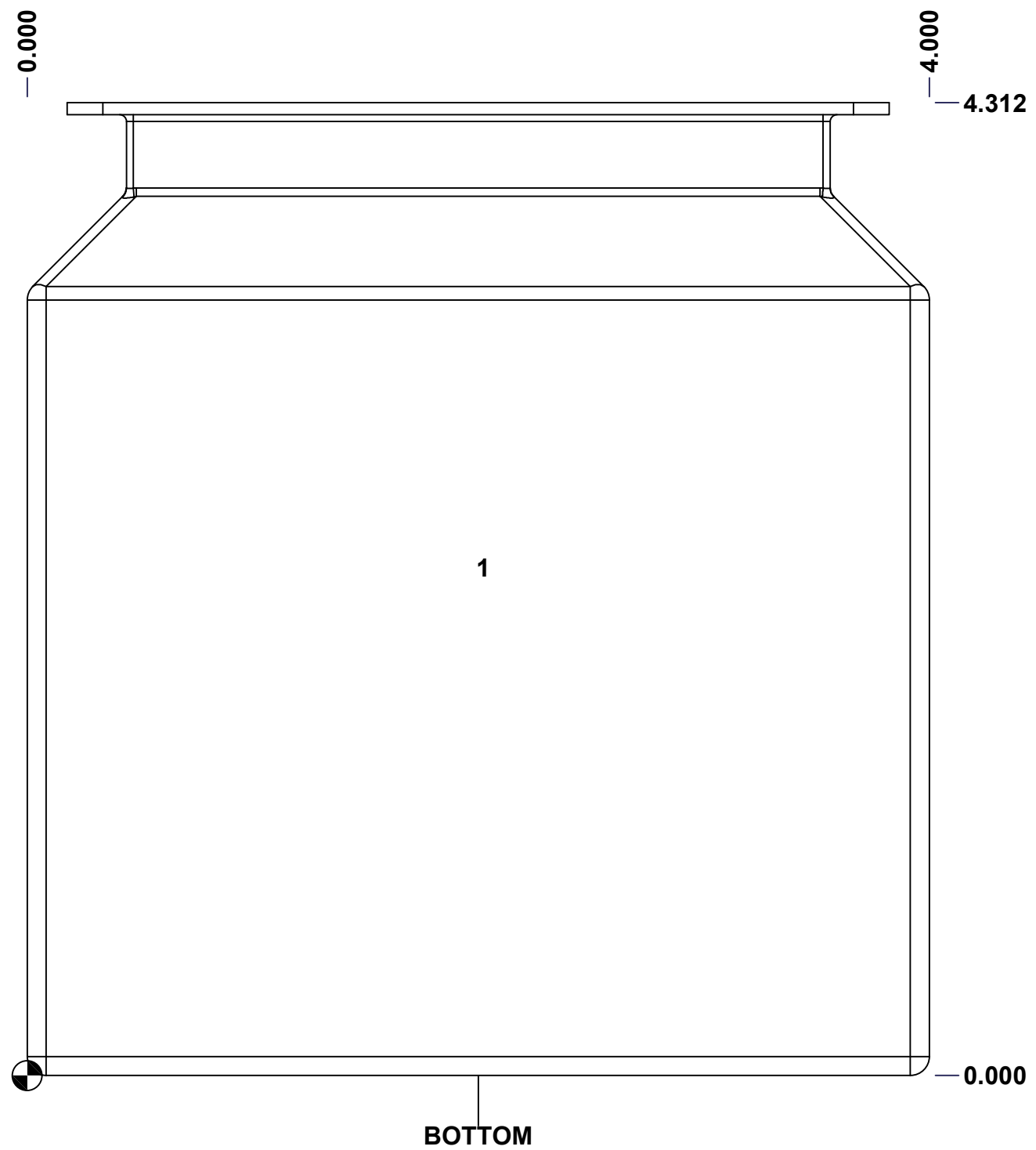

	Description	Status	
	5412ESSMPCH 6" x 4" x 4" Body	(NULL)	
	Part Number Numéro Pièce	Rev.	4
	5412ESSMPCH060404B	0	10

This drawing is confidential and must not be reproduced or used without the consent of EXM

Ce dessin est confidentiel et ne doit pas être reproduit ou utilisé sans le consentement de EXM

STANDARD FEATURES ARE NOT LISTED IN THIS HOLE TABLE

HOLE TABLE - LEFT VIEW (CUSTOM FEATURE ONLY)

CUT-OUT	XDIM	YDIM	DESCRIPTION
1	2.625	0.875	STANDOFF M6 x 10mm (Inside)

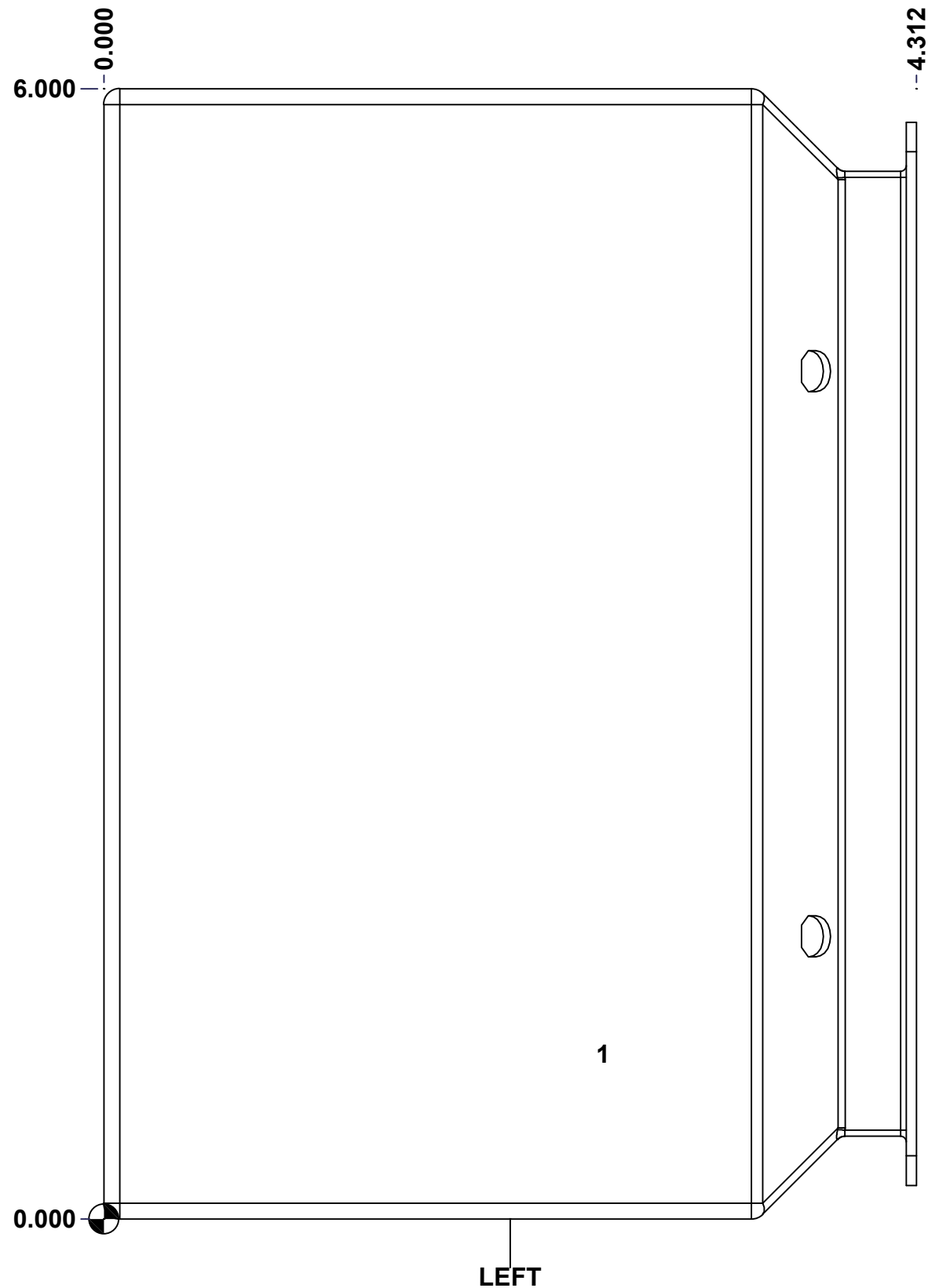

	Description	Status
	5412ESSMPCH 6" x 4" x 4" Body	(NULL)
Part Number Numéro Pièce 5412ESSMPCH060404B	Rev.	5
	0	10

This drawing is confidential and must not be reproduced or used without the consent of EXM

Ce dessin est confidentiel et ne doit pas être reproduit ou utilisé sans le consentement de EXM

STANDARD FEATURES ARE NOT LISTED IN THIS HOLE TABLE

HOLE TABLE - BACK VIEW (CUSTOM FEATURE ONLY)

CUT-OUT	XDIM	YDIM	DESCRIPTION
1	3.000	0.000	FOOT 885 ESCHMF2
2	1.000	0.000	FOOT 885 ESCHMF2
3	3.000	6.000	FOOT 885 ESCHMF2
4	1.000	6.000	FOOT 885 ESCHMF2
5	0.875	5.125	PEM FHS-M6-20 (Inside)
6	3.125	5.125	PEM FHS-M6-20 (Inside)
7	3.125	0.875	PEM FHS-M6-20 (Inside)
8	0.875	0.875	PEM FHS-M6-20 (Inside)

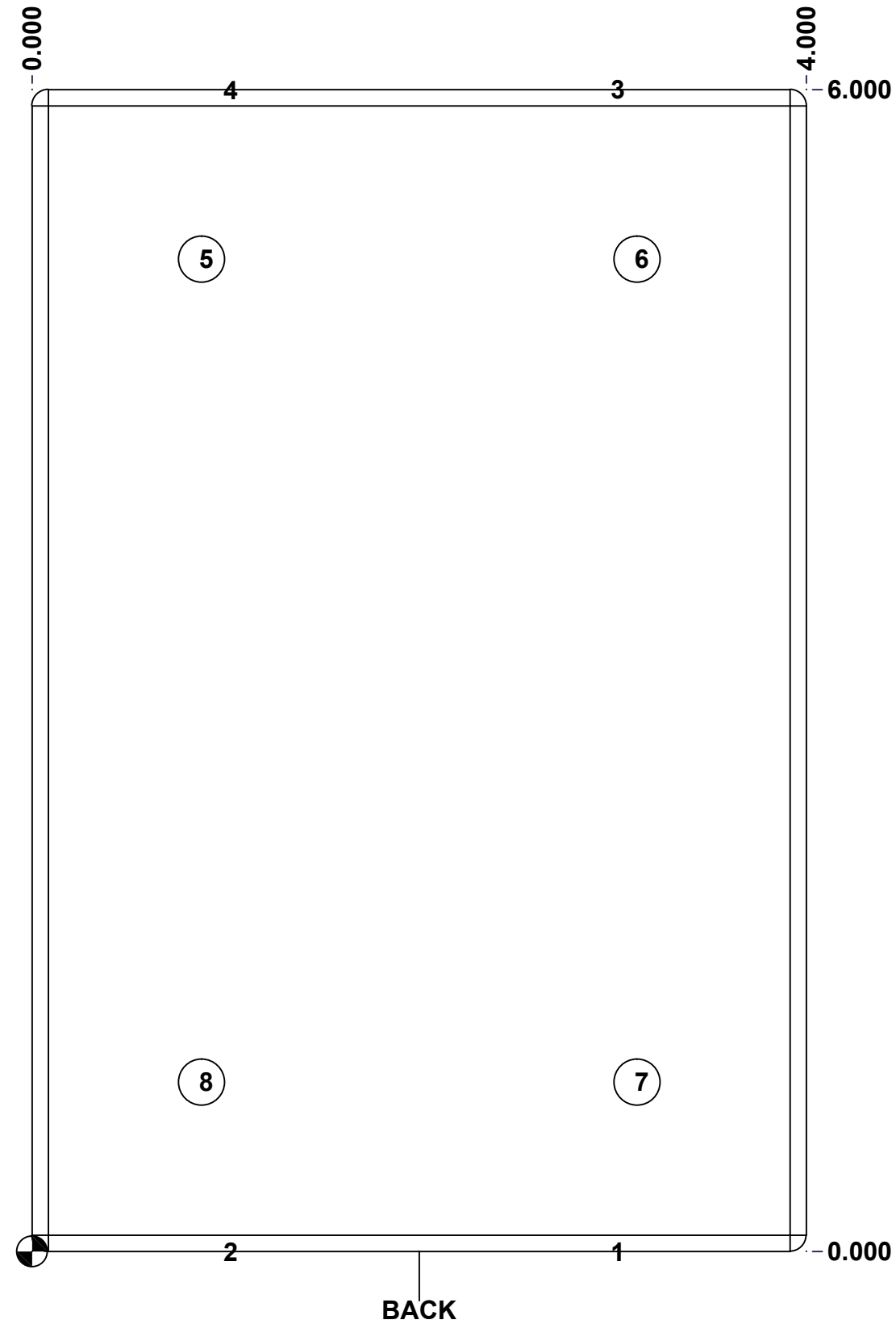

	Description	Status
	5412ESSMPCH 6" x 4" x 4" Body	(NULL)
	Part Number Numéro Pièce	Rev.
	5412ESSMPCH060404B	0 / 6
		10

This drawing is confidential and must not be reproduced or used without the consent of EXM

Ce dessin est confidentiel et ne doit pas être reproduit ou utilisé sans le consentement de EXM

No.	Revisions	Date	By/Par

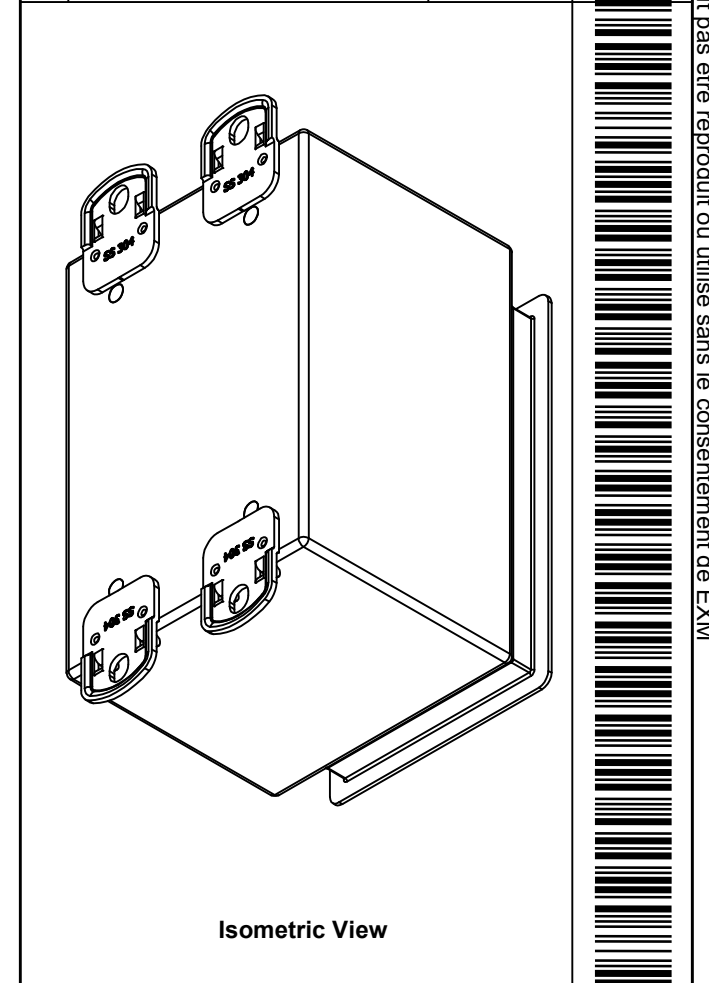

Isometric View

 Tél: (450) 979-4373
 Fax: (450) 979-4626
www.exmweb.com

Flatness / Aplatissement: Max 3.0mm
 Projection: 

Customer Client	Date
Drawn By / Dessiné Par: BoxCad: BoxCad	Date: 23-Nov-14

Material / Matière	16 Ga Stainless Steel 304 (1.4mm)
--------------------	-----------------------------------

Color / Couleur: Asa-61 Grey	Finish / Fini: Smooth
------------------------------	-----------------------

Description: 5412ESSMPCH 6" x 4" x 4" Body	Detail Rev.
--	-------------

Part Number / Numéro Pièce: 5412ESSMPCH060404B	Rev. 0	7 / 10
---	---------------	--------

Qty	Part Number	Rev	Description
4	STK-PEM-FHS-M6-20	0	SS PEM Self-Clinching Stud M6 x 20.0mm
1	STK-A-70469	6	5412 ESSMCH - Stainless Steel 316 Body Catch Assembly
1	STK-Q-08100	1	M5 Nylon Insert Lock Nut
1	STK-Q-08500	4	Stainless Steel Standoff M6 x 10mm
4	STK-Q-71316	4	5412 ESSMCH Stainless Steel Mounting Foot
1	5412ESSMPCH060404B-P	0	5412ESSMPCH 6" x 4" x 4" Body Part
1	STK-S-00100	0	3.5" x 2" Silver Milar Flexcon Sticker
1	STK-P-02400S	0	Powder Paint (Asa-61 Grey / Smooth)
Parts List			

This drawing is confidential and must not be reproduced or used without the consent of EXM

Ce dessin est confidentiel et ne doit pas être reproduit ou utilisé sans le consentement de EXM

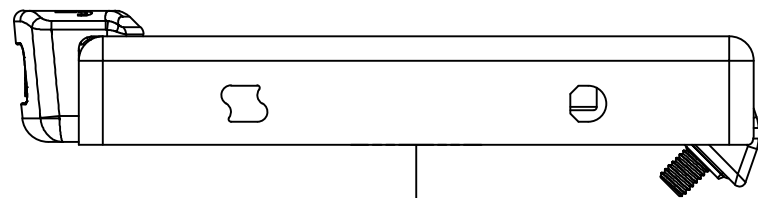

TOP

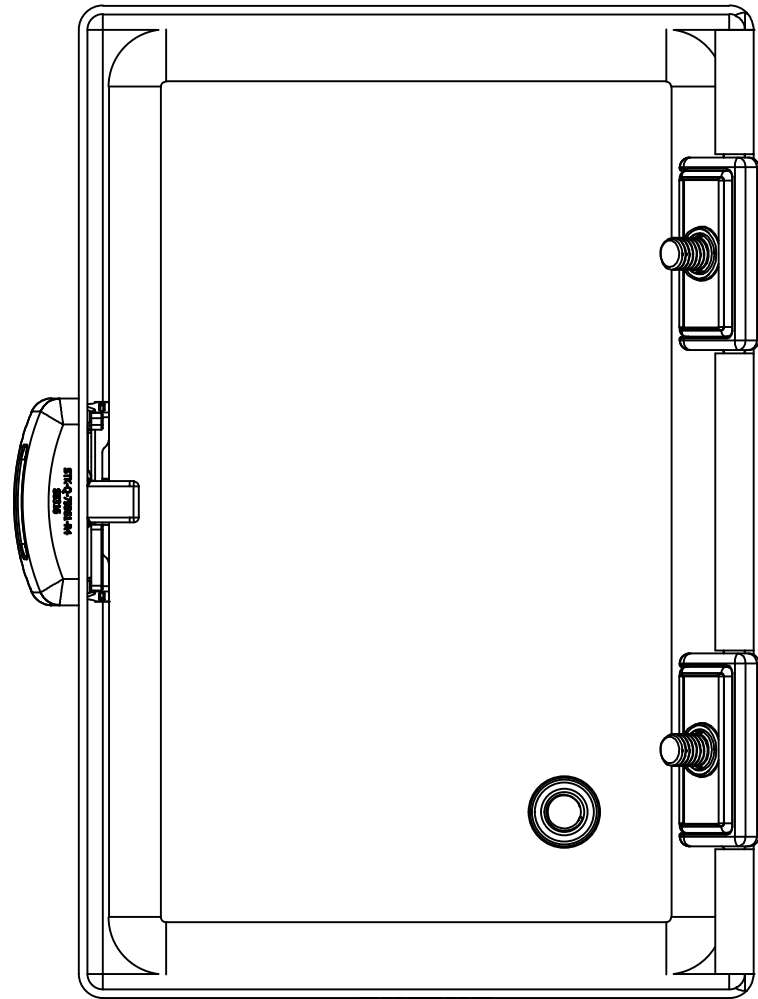

BACK

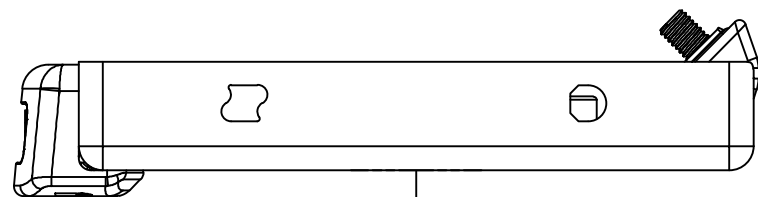

BOTTOM

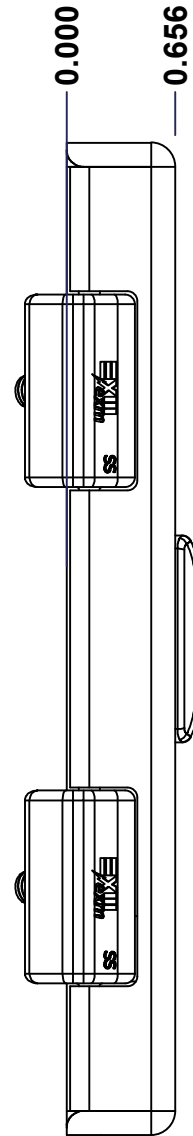

LEFT

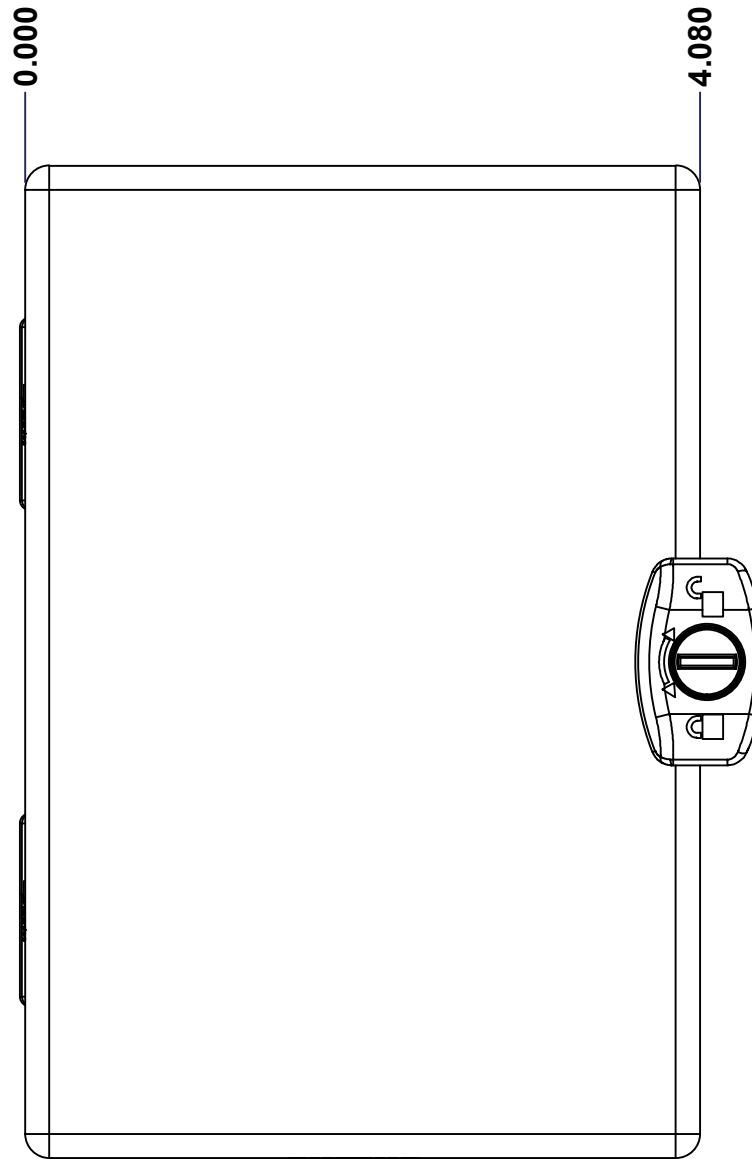

FRONT

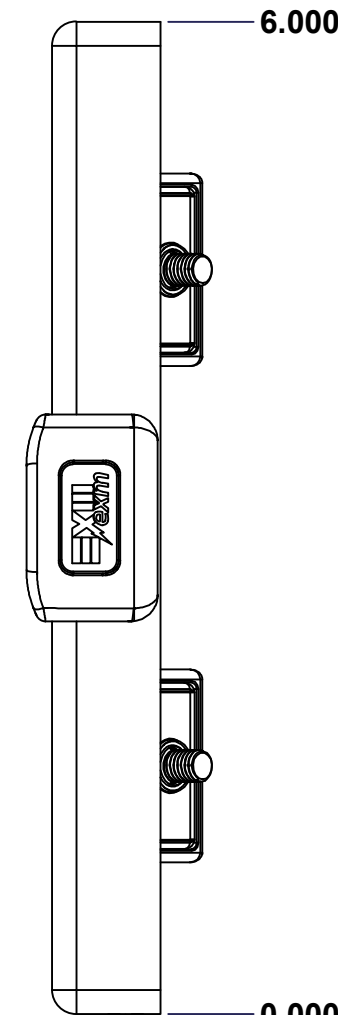

RIGHT

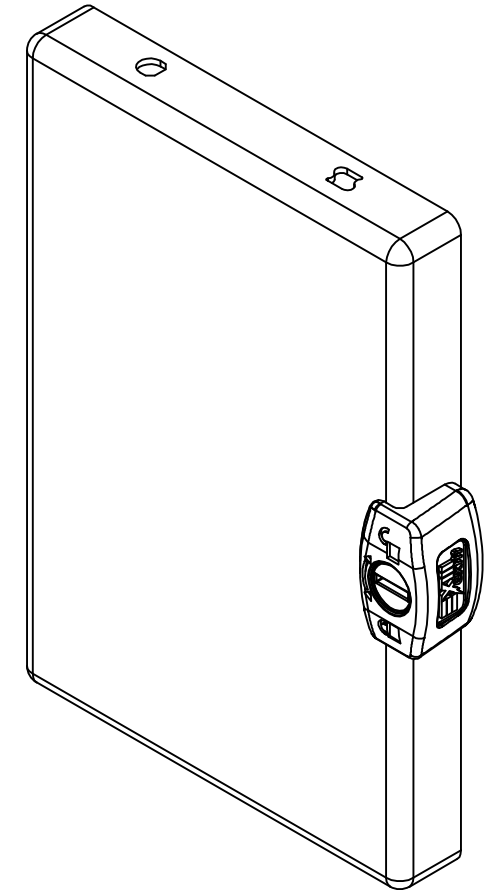

Isometric View

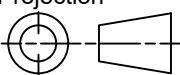

No.	Revisions	Date	By/Par

 Tél: (450) 979-4373 Fax: (450) 979-4626 www.exmweb.com		Flatness Aplatissement Max 3.0mm Projection 
Customer Client	Date	
Drawn By Dessiné Par	BoxCad: BoxCad	Date 23-Nov-14
Material Matière	16 Ga Stainless Steel 304 (1.4mm)	
Color Couleur	Asa-61 Grey	Finish Fini Smooth
Description	Detail Rev.	
5412ESSMPCH 6" x 4" Cover		
Part Number Numéro Pièce	Rev.	8
5412ESSMPCH060404C	0	10

SEE BILL OF MATERIAL ON LAST PAGE

This drawing is confidential and must not be reproduced or used without the consent of EXM

Ce dessin est confidentiel et ne doit pas être reproduit ou utilisé sans le consentement de EXM

STANDARD FEATURES ARE NOT LISTED IN THIS HOLE TABLE			
HOLE TABLE - FRONT VIEW (CUSTOM FEATURE ONLY)			
CUT-OUT	XDIM	YDIM	DESCRIPTION
1	4.080	3.000	LOCK 880 SCQ3MS @ 0.0°
2	1.145	1.125	STANDOFF M6 x 10mm (Inside)

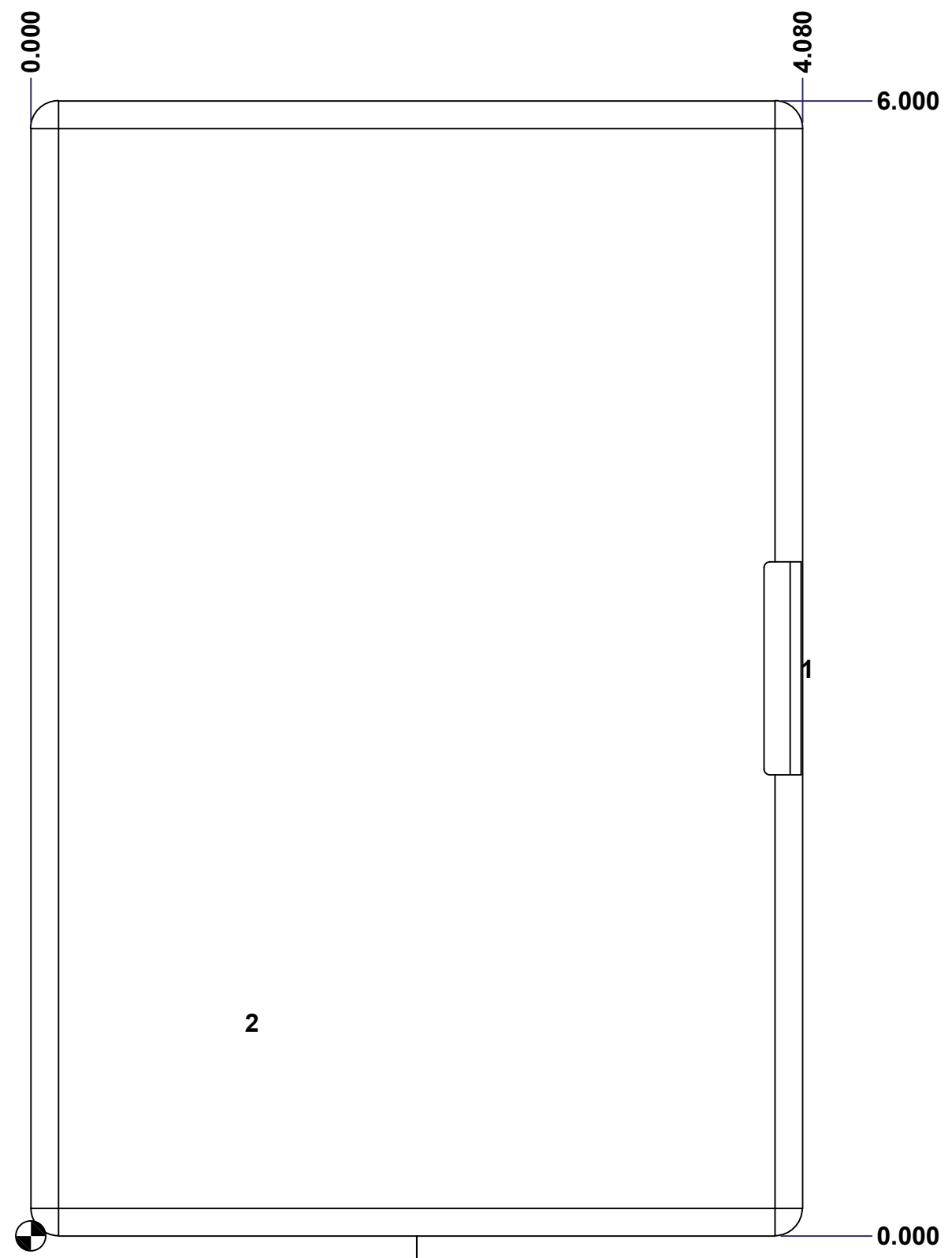

FRONT

	Description	Status
	5412ESSMPCH 6" x 4" Cover	(NULL)
	Part Number Numéro Pièce	Rev.
	5412ESSMPCH060404C	0
		9
		10

This drawing is confidential and must not be reproduced or used without the consent of EXM

Ce dessin est confidentiel et ne doit pas être reproduit ou utilisé sans le consentement de EXM

No.	Revisions	Date	By/Par

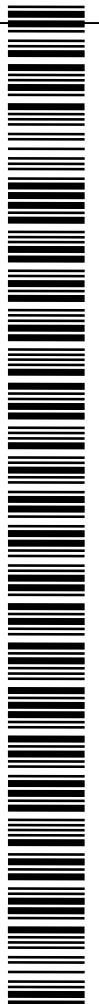
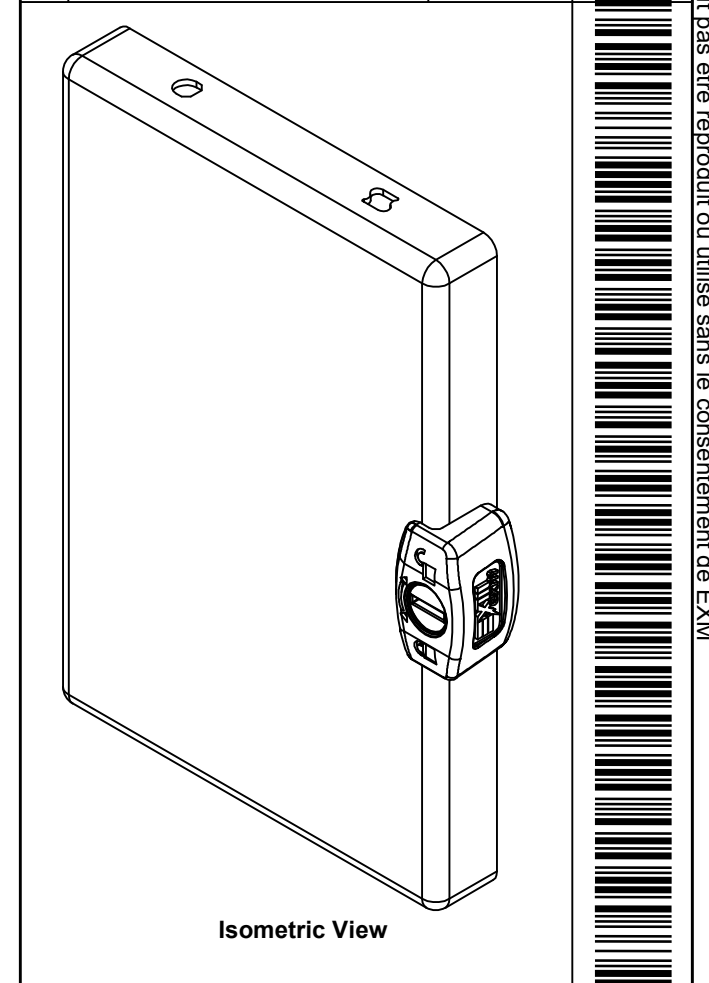

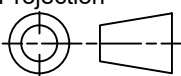
 Tél: (450) 979-4373 Fax: (450) 979-4626 www.exmweb.com		Flatness Aplatissement Max 3.0mm Projection 
Customer Client	Date	
Drawn By Dessiné Par	BoxCad: BoxCad	Date 23-Nov-14
Material Matière	16 Ga Stainless Steel 304 (1.4mm)	
Color Couleur	Asa-61 Grey	Finish Fini Smooth
Description		Detail Rev.
5412ESSMPCH 6" x 4" Cover		
Part Number Numéro Pièce	Rev.	10
5412ESSMPCH060404C	0	10

Qty	Part Number	Rev	Description
1	5412ESSMPCH060404G	0	5412ESSMPCH 6" x 4" Gasket
1	STK-Q-08500	4	Stainless Steel Standoff M6 x 10mm
1	880SCQ3S	4	5412 ESSMCH - Stainless Steel External Lock Assy - Slot Lock
1	STK-P-02400S	0	Powder Paint (Asa-61 Grey / Smooth)
1	5412ESSMPCH060404C-P	0	5412ESSMPCH 6" x 4" Cover Part
2	STK-A-33038	3	5412 ESSMCH - Stainless Steel Hinge
Parts List			

This drawing is confidential and must not be reproduced or used without the consent of EXM

Ce dessin est confidentiel et ne doit pas être reproduit ou utilisé sans le consentement de EXM

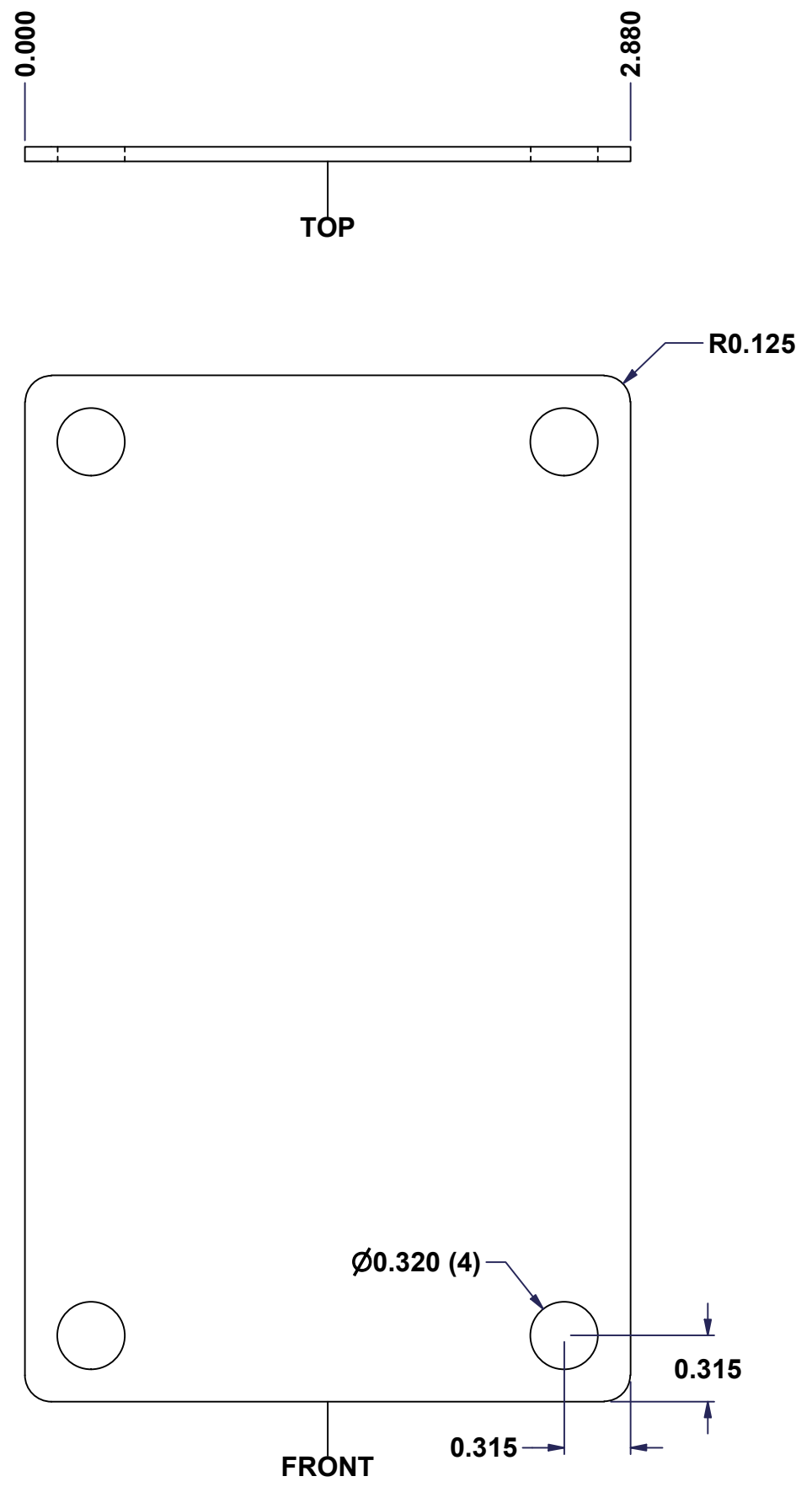

No.	Revisions	Date	By/Par

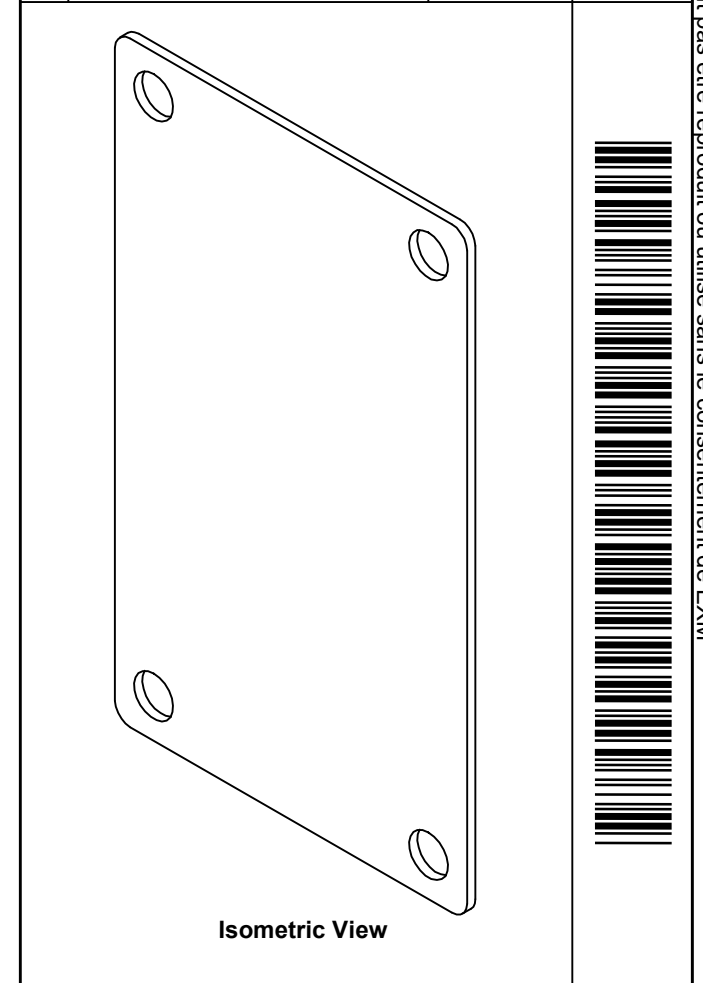

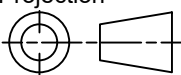
 Tél: (450) 979-4373 Fax: (450) 979-4626 www.exmweb.com		Flatness Aplatissement Max 3.0mm
Customer Client		Projection 
Drawn By / Dessiné Par: BoxCad		Date: 23-Jan-07
Material / Matière: 14 Ga Galvanized (1.7mm)		
Color / Couleur: Unpainted	Finish / Fini: Galvanized	
Description: 880 SP0604G - Inner Panel		Detail Rev.
Part Number / Numéro Pièce: 880 SP0604G		Rev. 1 0

SEE BILL OF MATERIAL ON LAST PAGE

This drawing is confidential and must not be reproduced or used without the consent of EXM

Ce dessin est confidentiel et ne doit pas être reproduit ou utilisé sans le consentement de EXM

No.	Revisions	Date	By/Par

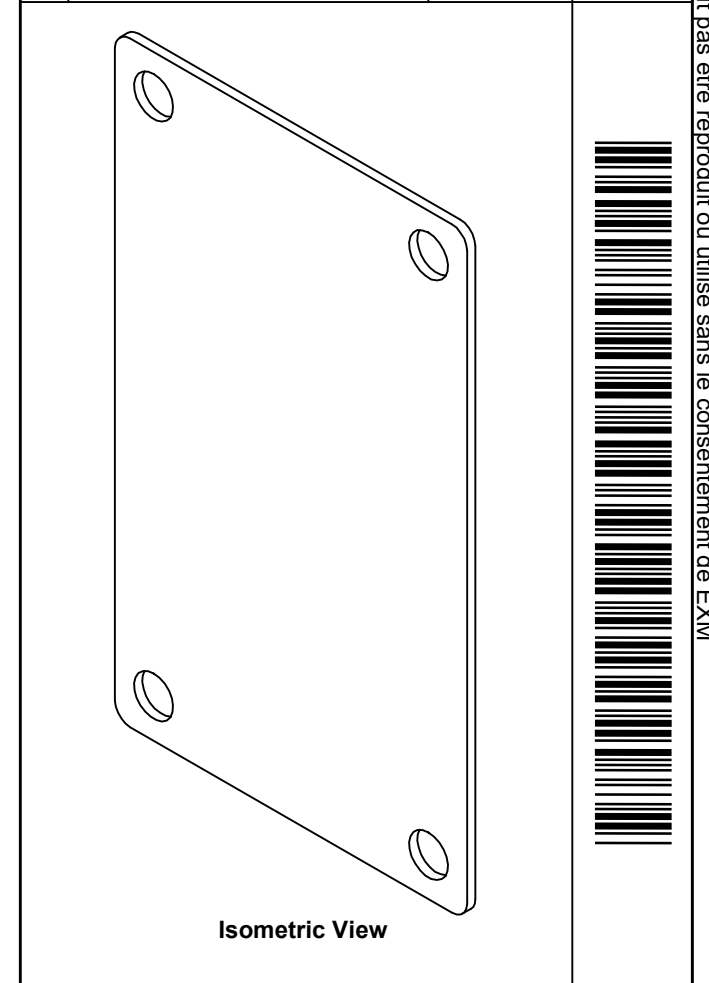

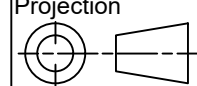
 Tél: (450) 979-4373 Fax: (450) 979-4626 www.exmweb.com		Flatness Aplatissement Max 3.0mm
Customer Client		Projection 
Drawn By / Dessiné Par: BoxCad		Date: 23-Jan-07
Material / Matière: 14 Ga Galvanized (1.7mm)		
Color / Couleur: Unpainted	Finish / Fini: Galvanized	
Description: 880 SP0604G - Inner Panel		Detail Rev.
Part Number / Numéro Pièce: 880 SP0604G		Rev. 0 / 2

Qty	Part Number	Rev	Description
1	880 SP0604G-P	0	880 SP0604G - Inner Panel Part
Parts List			