

This drawing is confidential and must not be reproduced or used without the consent of EXM

Ce dessin est confidentiel et ne doit pas être reproduit ou utilisé sans le consentement de EXM

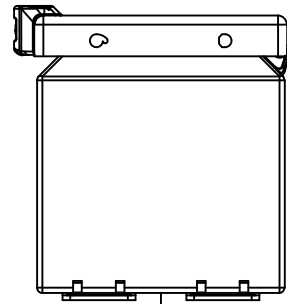

TOP

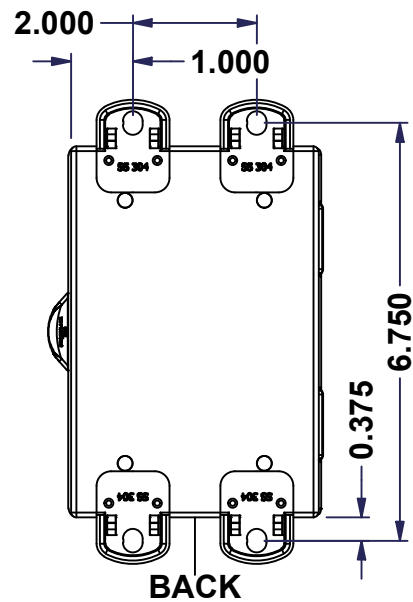

BACK

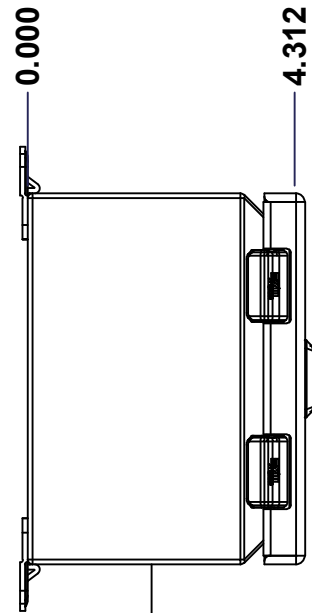

LEFT

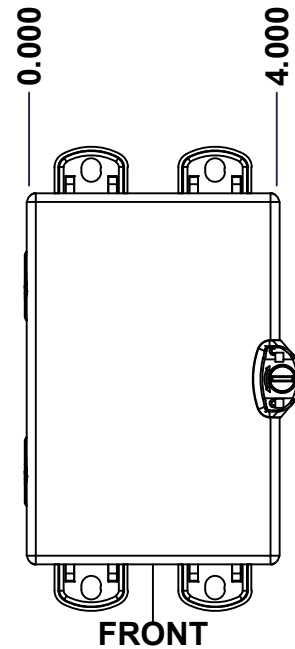

FRONT

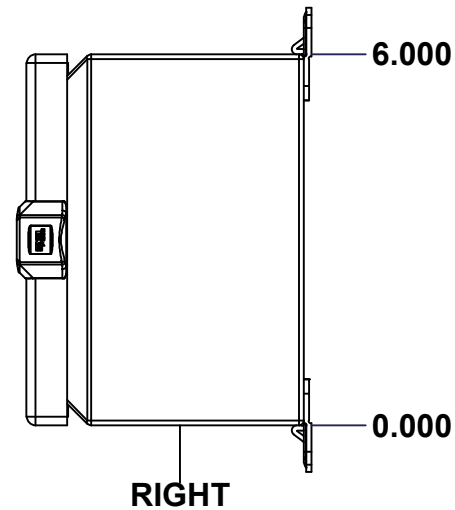

RIGHT

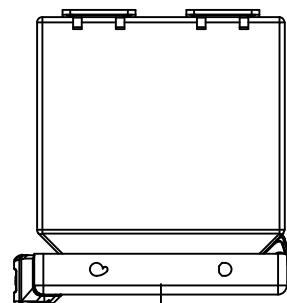

BOTTOM

No.	Revisions	Date	By/Par

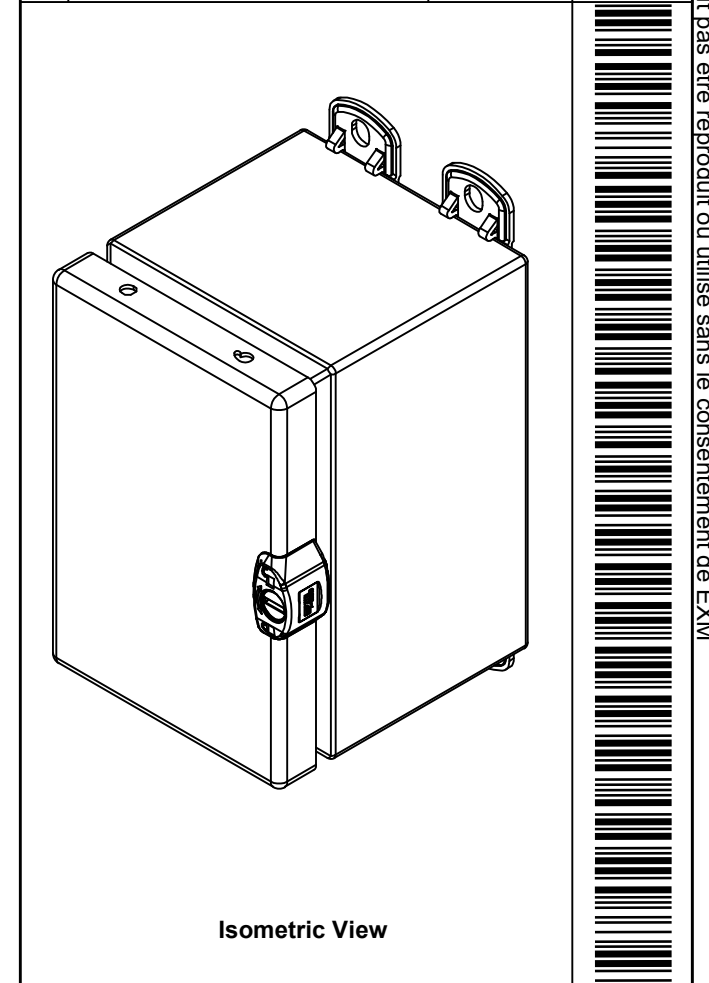

Isometric View

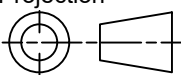

 Tél: (450) 979-4373 Fax: (450) 979-4626 www.exmweb.com		Flatness Aplatissement Max 3.0mm Projection 
Customer Client	Date	
Drawn By Dessiné Par	BoxCad: BoxCad	Date 28-Jan-26
Material Matière	16 Ga Stainless Steel 316 (1.4mm)	
Color Couleur	Asa-61 Grey	Finish Fini Smooth
Description	Detail Rev.	
5412ESSPCH 6" x 4" x 4" Assembly		
Part Number Numéro Pièce	Rev.	1
5412ESSPCH0604046	0	10

SEE BILL OF MATERIAL ON LAST PAGE

This drawing is confidential and must not be reproduced or used without the consent of EXM

Ce dessin est confidentiel et ne doit pas être reproduit ou utilisé sans le consentement de EXM

NOTE	
ITEM	DESCRIPTION
1	NEMA 4X Enclosure (IP66)
2	C/W Standard ground standoffs on box and cover
3	W/O Standard door stiffener
4	C/W Standard inner panel (Included)
5	C/W Standard inner panel mounting standoffs
6	C/W 885 ESCHMF2 Mounting Feet (Welded)

No.	Revisions	Date	By/Par

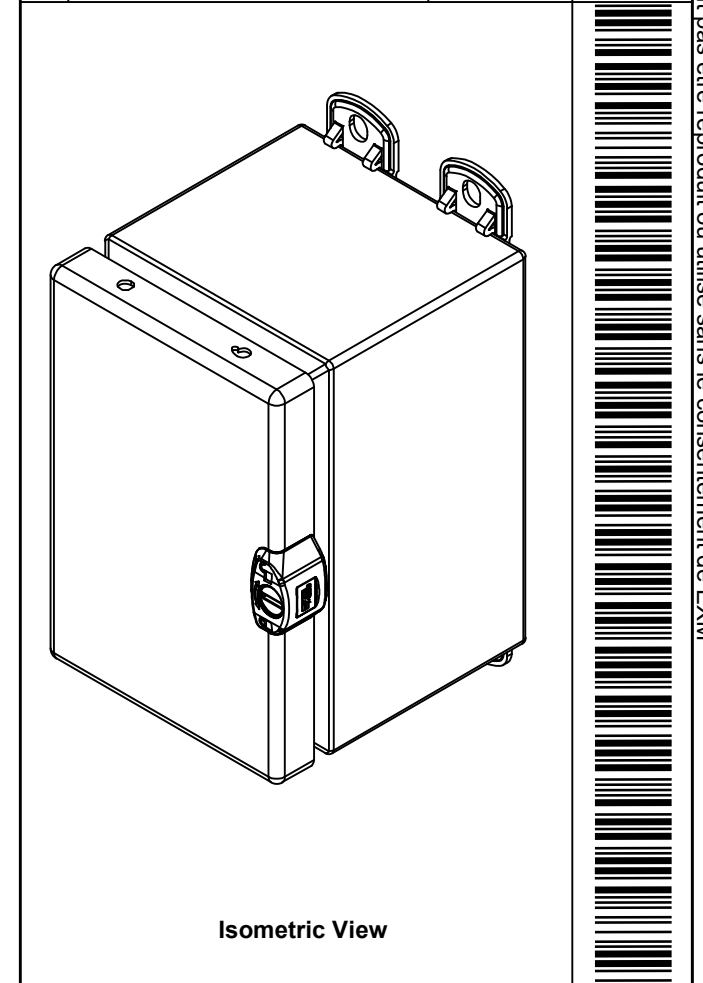

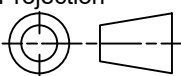
 Tél: (450) 979-4373 Fax: (450) 979-4626 www.exmweb.com	Flatness Aplatissement Max 3.0mm
	Projection 
Customer Client	Date
Drawn By / Dessiné Par: BoxCad: BoxCad	Date: 28-Jan-26
Material / Matière: 16 Ga Stainless Steel 316 (1.4mm)	
Color / Couleur: Asa-61 Grey	Finish / Fini: Smooth
Description: 5412ESSPCH 6" x 4" x 4" Assembly	Detail Rev.
Part Number / Numéro Pièce: 5412ESSPCH0604046	Rev. 0

Qty	Part Number	Rev	Description
2	STK-A-08126	0	M5 Stainless Steel 316 Nylon Insert Lock Nut with Incorporated Sealing Washer
1	5412ESSPCH0604046C	0	5412ESSPCH 6" x 4" Cover
1	STK-K-02910	3	5412 ESCH Accessory Kit
1	880 SP0604G	0	880 SP0604G - Inner Panel
8	STK-Q-07210	0	Flange Lock Nut M6
1	5412ESSPCH0604046B	0	5412ESSPCH 6" x 4" x 4" Body

Parts List

PACKING		
ITEM	QTY	DESCRIPTION
STK-E-04302	1	CARTON 5412 ESCH060404
Plastic bag	1	To protect cover surface and inside gasket
Packaging label	1	White label with product number
STK-S-01100	1	ESCH EXM SQUARE STICKER

This drawing is confidential and must not be reproduced or used without the consent of EXM

Ce dessin est confidentiel et ne doit pas être reproduit ou utilisé sans le consentement de EXM

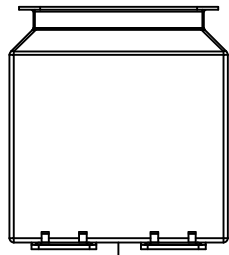

TOP

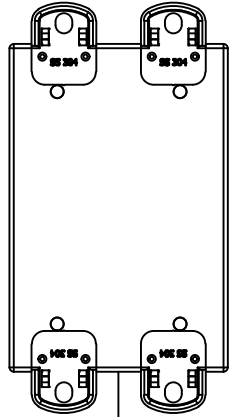

BACK

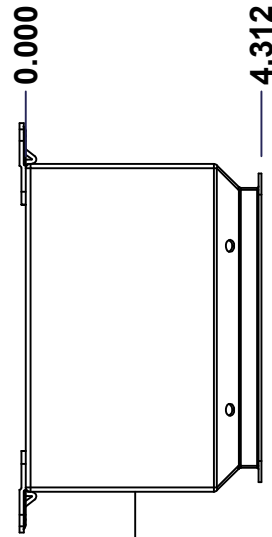

LEFT

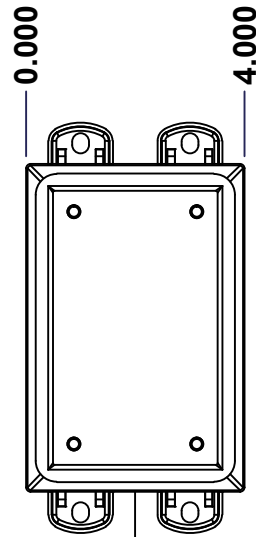

FRONT

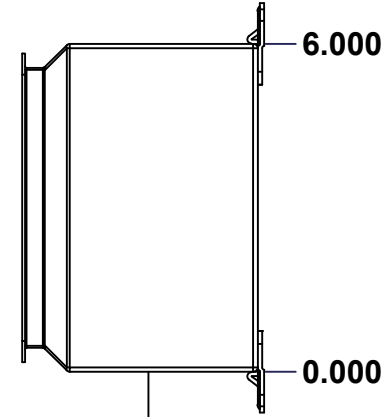

RIGHT

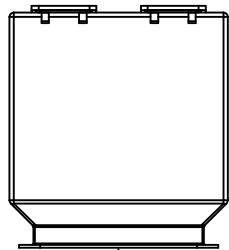

BOTTOM

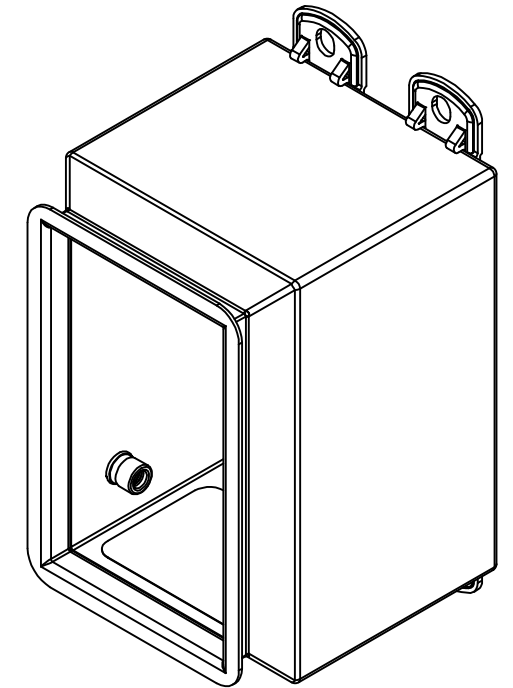

Isometric View



Tél: (450) 979-4373
 Fax: (450) 979-4626
www.exmweb.com

Flatness
Aplatissement

Max 3.0mm

Projection

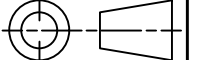

Customer Client	Date
Drawn By Dessiné Par BoxCad: BoxCad	Date 28-Jan-26
Material Matière 16 Ga Stainless Steel 316 (1.4mm)	
Color Couleur Asa-61 Grey	Finish Fini Smooth
Description 5412ESSPCH 6" x 4" x 4" Body	Detail Rev.
Part Number Numéro Pièce 5412ESSPCH0604046B	Rev. 3
	0

SEE BILL OF MATERIAL ON LAST PAGE

5412ESSPCH0604046B

10

This drawing is confidential and must not be reproduced or used without the consent of EXM

Ce dessin est confidentiel et ne doit pas être reproduit ou utilisé sans le consentement de EXM

STANDARD FEATURES ARE NOT LISTED IN THIS HOLE TABLE			
HOLE TABLE - BOTTOM VIEW (CUSTOM FEATURE ONLY)			
CUT-OUT	XDIM	YDIM	DESCRIPTION
1	2.000	2.250	LABEL_EXM (Inside)

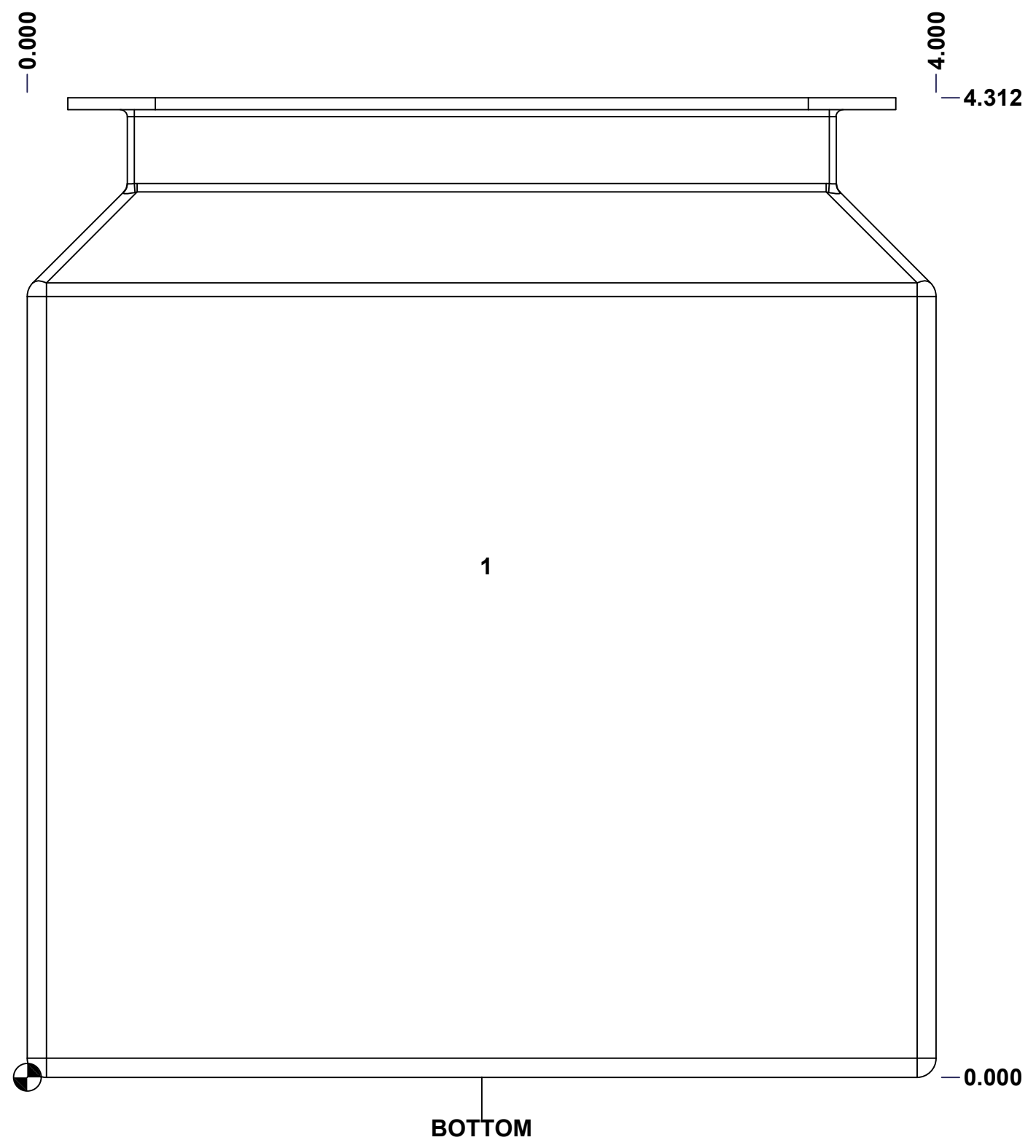

	Description	Status
	5412ESSPCH 6" x 4" x 4" Body	(NULL)
	Part Number Numéro Pièce	Rev.
	5412ESSPCH0604046B	0 / 4
		10

This drawing is confidential and must not be reproduced or used without the consent of EXM

Ce dessin est confidentiel et ne doit pas être reproduit ou utilisé sans le consentement de EXM

STANDARD FEATURES ARE NOT LISTED IN THIS HOLE TABLE			
HOLE TABLE - LEFT VIEW (CUSTOM FEATURE ONLY)			
CUT-OUT	XDIM	YDIM	DESCRIPTION
1	2.625	0.875	STANDOFF M6 x 10mm (Inside)

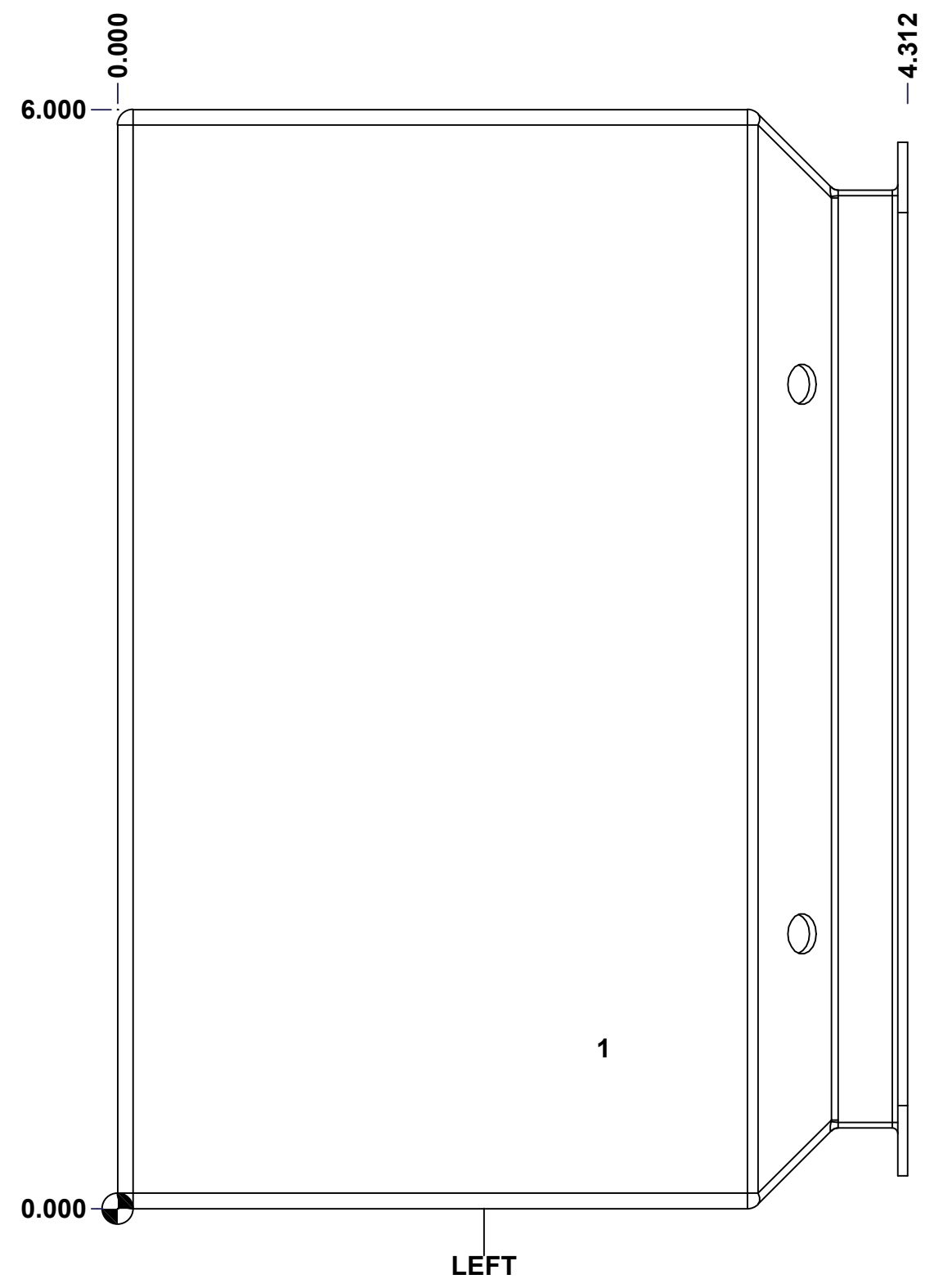

	Description	Status
	5412ESSPCH 6" x 4" x 4" Body	(NULL)
Part Number Numéro Pièce	5412ESSPCH0604046B	Rev. 5
		0 / 10

This drawing is confidential and must not be reproduced or used without the consent of EXM

Ce dessin est confidentiel et ne doit pas être reproduit ou utilisé sans le consentement de EXM

STANDARD FEATURES ARE NOT LISTED IN THIS HOLE TABLE

HOLE TABLE - BACK VIEW (CUSTOM FEATURE ONLY)

CUT-OUT	XDIM	YDIM	DESCRIPTION
1	1.000	0.000	FOOT 885 ESCHMF2
2	1.000	6.000	FOOT 885 ESCHMF2
3	3.000	0.000	FOOT 885 ESCHMF2
4	3.000	6.000	FOOT 885 ESCHMF2
5	3.125	5.125	PEM FHS-M6-20 (Inside)
6	0.875	5.125	PEM FHS-M6-20 (Inside)
7	0.875	0.875	PEM FHS-M6-20 (Inside)
8	3.125	0.875	PEM FHS-M6-20 (Inside)

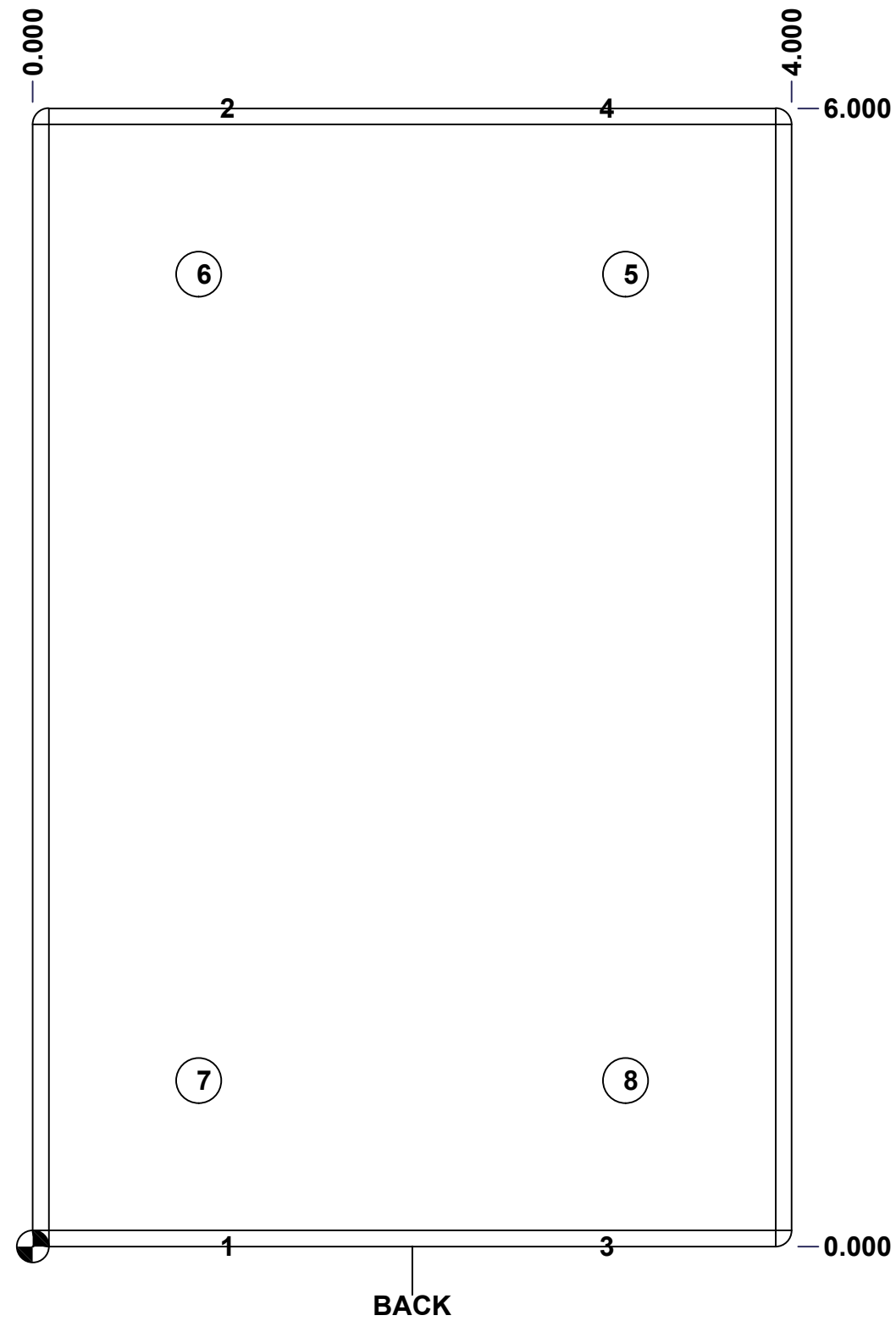



	Description	Status
	5412ESSPCH 6" x 4" x 4" Body	(NULL)
	Part Number Numéro Pièce	Rev.
	5412ESSPCH0604046B	0 / 6
		10

This drawing is confidential and must not be reproduced or used without the consent of EXM

Ce dessin est confidentiel et ne doit pas être reproduit ou utilisé sans le consentement de EXM

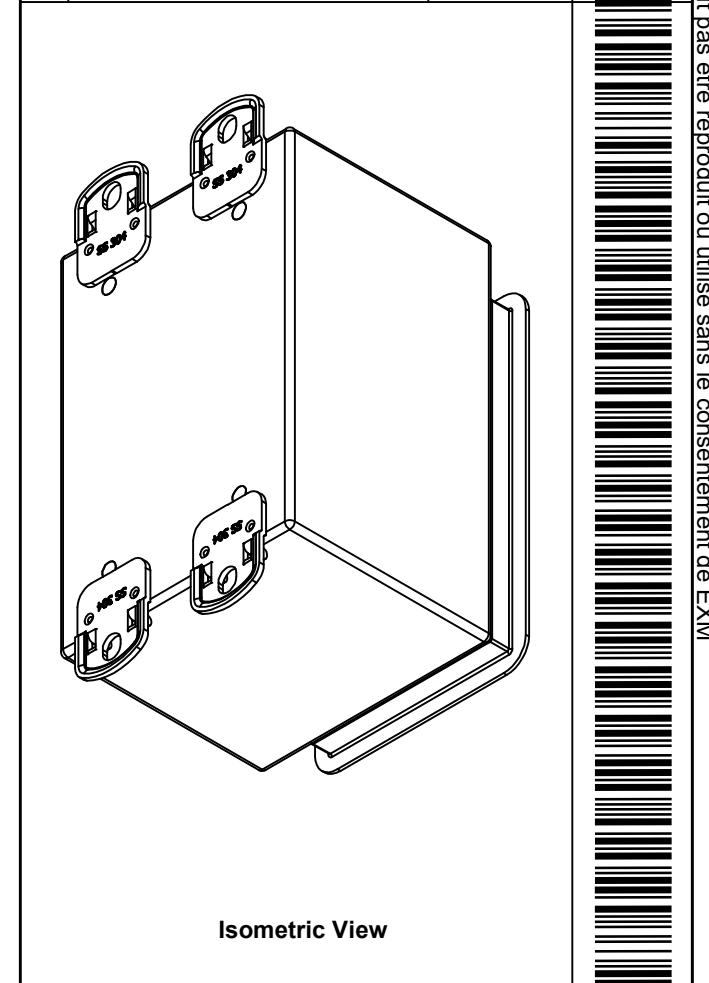
No.	Revisions	Date	By/Par

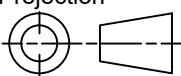

 Tél: (450) 979-4373 Fax: (450) 979-4626 www.exmweb.com		Flatness Aplatissement Max 3.0mm Projection 
Customer Client	Date	
Drawn By Dessiné Par	BoxCad: BoxCad	Date 28-Jan-26
Material Matière	16 Ga Stainless Steel 316 (1.4mm)	
Color Couleur	Asa-61 Grey	Finish Fini Smooth
Description		Detail Rev.
5412ESSPCH 6" x 4" x 4" Body		
Part Number Numéro Pièce	Rev. 0	7 / 10
5412ESSPCH0604046B		

Qty	Part Number	Rev	Description
4	STK-PEM-FHS-M6-20	0	SS PEM Self-Clinching Stud M6 x 20.0mm
1	STK-Q-08500	4	Stainless Steel Standoff M6 x 10mm
1	STK-S-00100	0	3.5" x 2" Silver Milar Flexcon Sticker
4	STK-Q-71316	4	5412 ESSMCH Stainless Steel Mounting Foot
1	STK-P-02400S	0	Powder Paint (Asa-61 Grey / Smooth)
1	5412ESSPCH0604046B-P	0	5412ESSPCH 6" x 4" x 4" Body Part
Parts List			

This drawing is confidential and must not be reproduced or used without the consent of EXM

Ce dessin est confidentiel et ne doit pas être reproduit ou utilisé sans le consentement de EXM

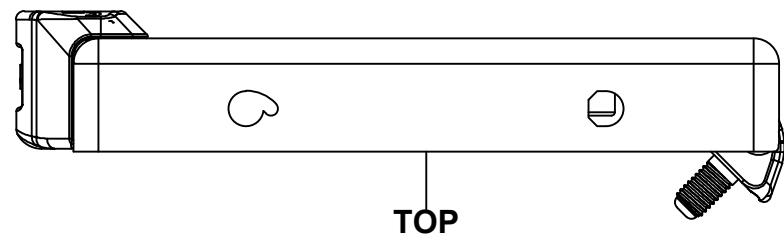

TOP

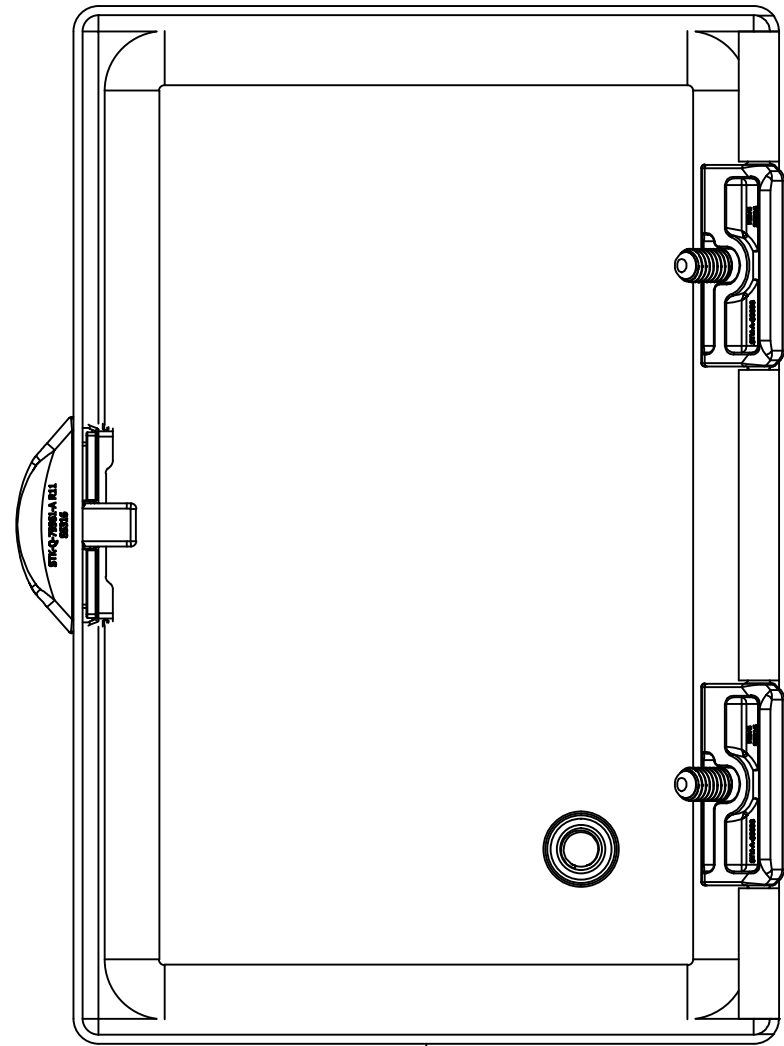

BACK

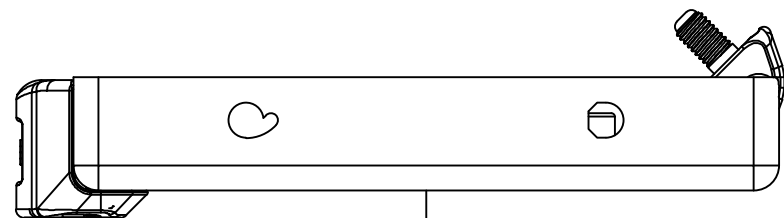

BOTTOM

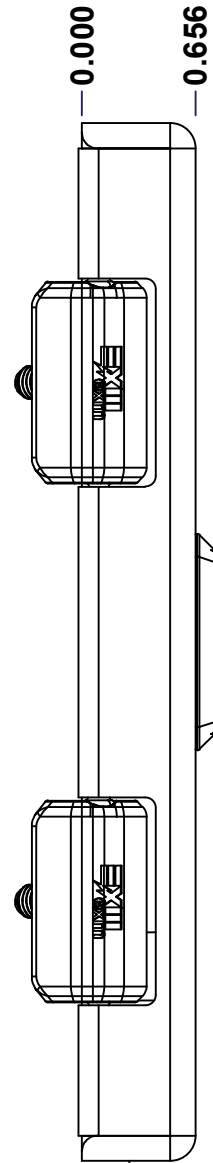

LEFT

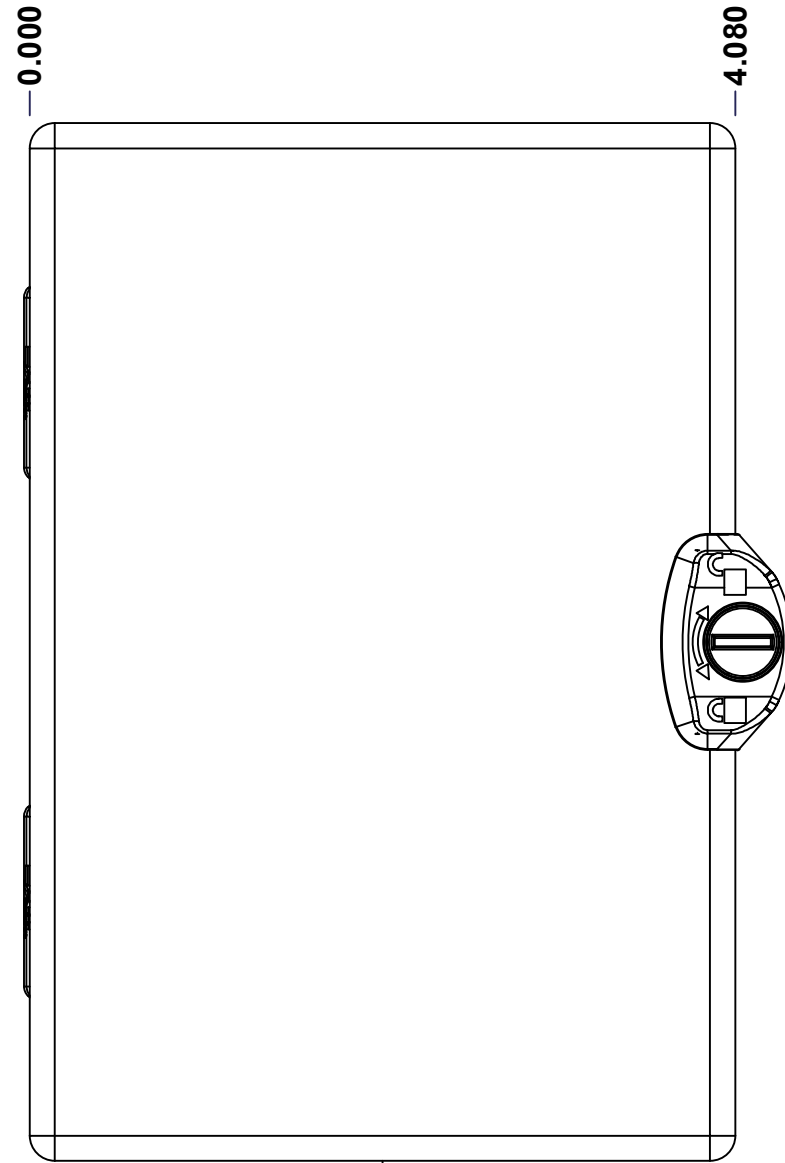

FRONT

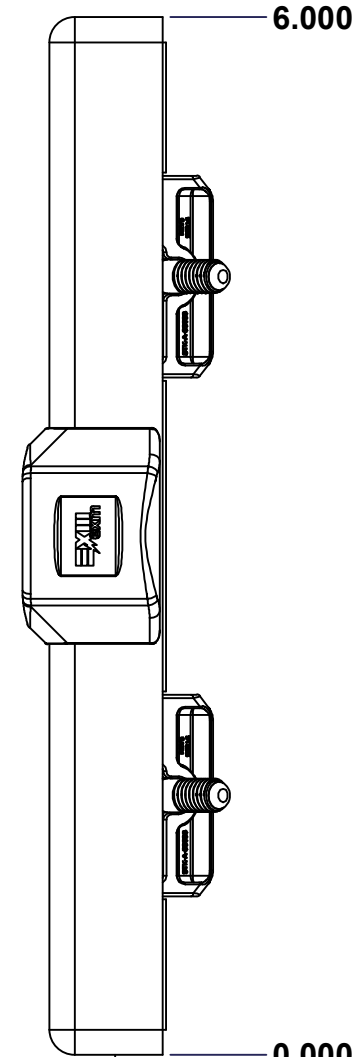

RIGHT

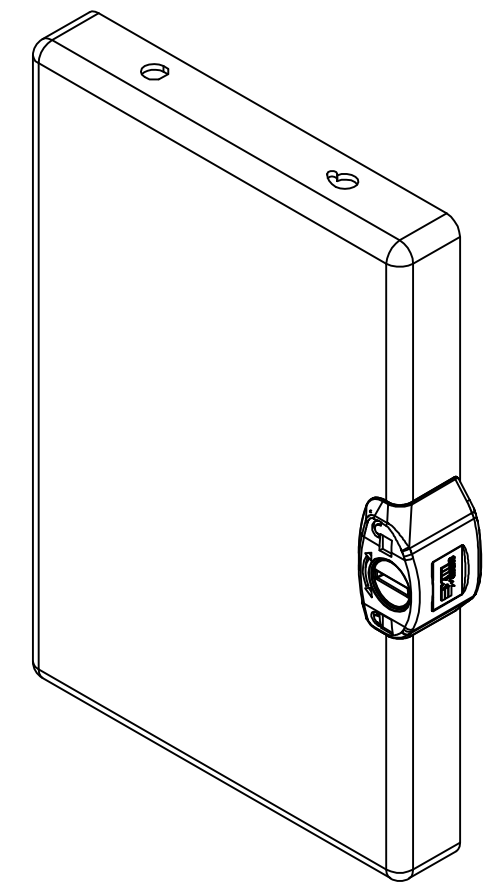

Isometric View



No.	Revisions	Date	By/Par

		Flatness Aplatissement Max 3.0mm Projection 	
Customer Client		Date	
Drawn By Dessiné Par BoxCad: BoxCad		Date 28-Jan-26	
Material Matière 16 Ga Stainless Steel 316 (1.4mm)			
Color Couleur Asa-61 Grey		Finish Fini Smooth	
Description 5412ESSPCH 6" x 4" Cover			Detail Rev.
Part Number Numéro Pièce 5412ESSPCH0604046C		Rev. 0	8 / 10

SEE BILL OF MATERIAL ON LAST PAGE

This drawing is confidential and must not be reproduced or used without the consent of EXM

Ce dessin est confidentiel et ne doit pas être reproduit ou utilisé sans le consentement de EXM

STANDARD FEATURES ARE NOT LISTED IN THIS HOLE TABLE			
HOLE TABLE - FRONT VIEW (CUSTOM FEATURE ONLY)			
CUT-OUT	XDIM	YDIM	DESCRIPTION
1	1.145	1.125	STANDOFF M6 x 10mm (Inside)
2	4.080	3.000	LOCK 880 SCQ2-SLSS @ 0.0°

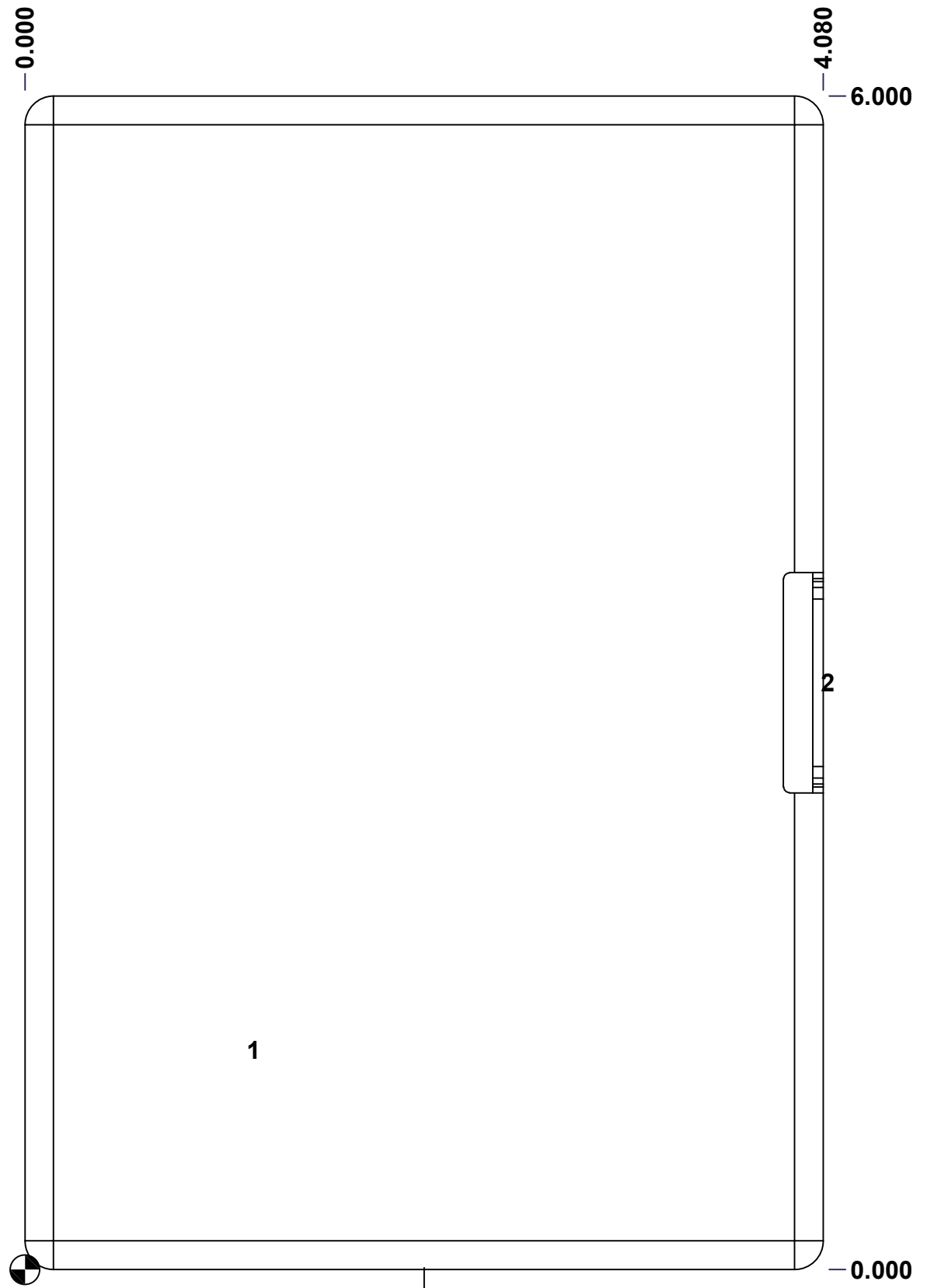

FRONT

	Description	Status
	5412ESSPCH 6" x 4" Cover	(NULL)
	Part Number Numéro Pièce	Rev.
	5412ESSPCH0604046C	0
		9
		10

This drawing is confidential and must not be reproduced or used without the consent of EXM

Ce dessin est confidentiel et ne doit pas être reproduit ou utilisé sans le consentement de EXM

No.	Revisions	Date	By/Par

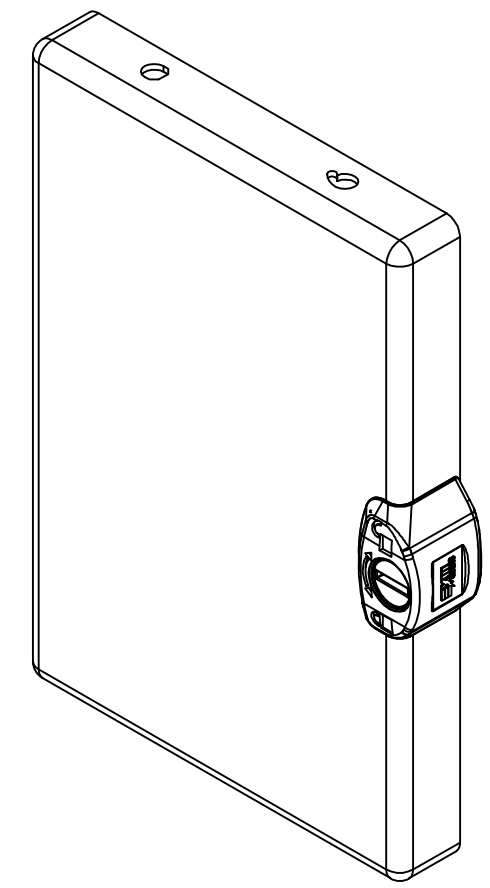

Isometric View

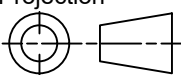

 Tél: (450) 979-4373 Fax: (450) 979-4626 www.exmweb.com		Flatness Aplatissement Max 3.0mm Projection 
Customer Client	Date	
Drawn By Dessiné Par	BoxCad: BoxCad	Date 28-Jan-26
Material Matière	16 Ga Stainless Steel 316 (1.4mm)	
Color Couleur	Asa-61 Grey	Finish Fini Smooth
Description		Detail Rev.
5412ESSPCH 6" x 4" Cover		
Part Number Numéro Pièce	Rev.	10
5412ESSPCH0604046C	0	10

QTY	Part Number	Rev	Description
1	STK-A-79961	11	5412 ESSMCH - Stainless Steel External Lock Assy - Slot Lock
1	STK-Q-08500	4	Stainless Steel Standoff M6 x 10mm
1	STK-P-02400S	0	Powder Paint (Asa-61 Grey / Smooth)
2	STK-A-33038	5	5412 ESSCH Hinge Assembly
1	5412ESSPCH0604046G	0	5412ESSPCH 6" x 4" Gasket
1	5412ESSPCH0604046C-P	0	5412ESSPCH 6" x 4" Cover Part
Parts List			

This drawing is confidential and must not be reproduced or used without the consent of EXM

Ce dessin est confidentiel et ne doit pas être reproduit ou utilisé sans le consentement de EXM

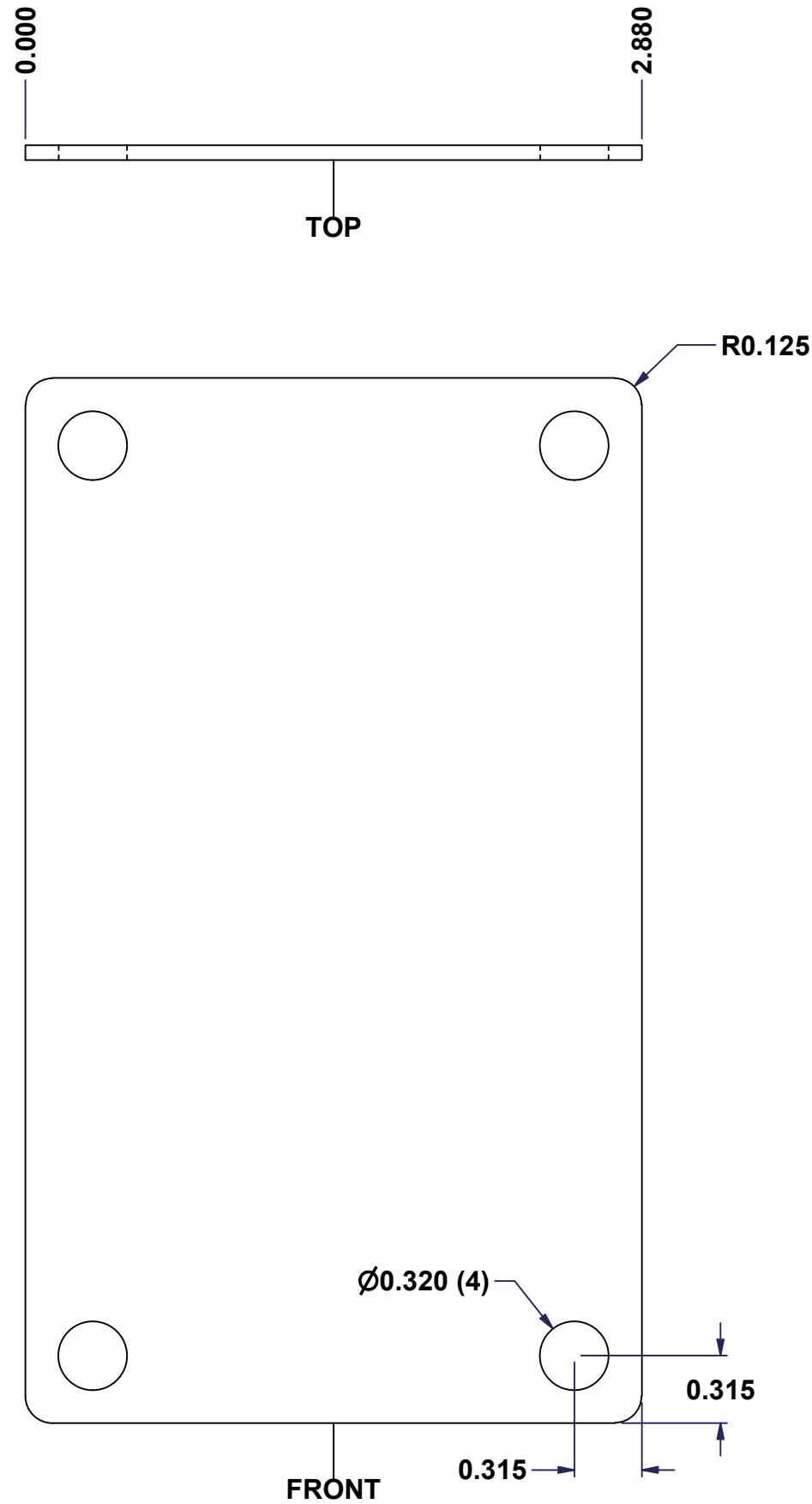

No.	Revisions	Date	By/Par

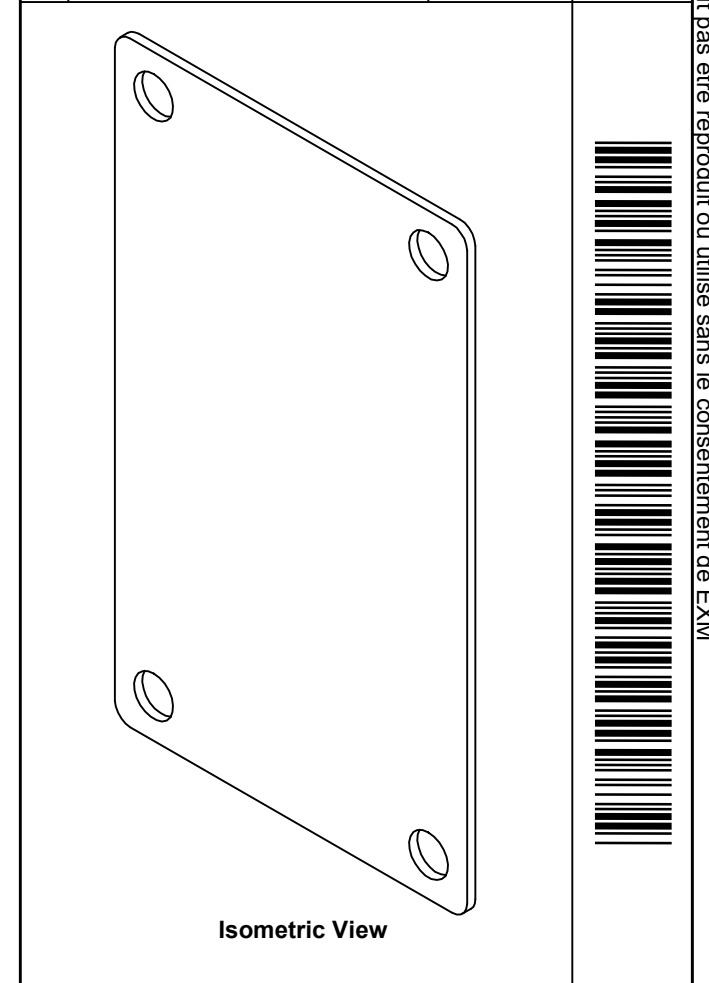

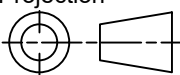
 Tél: (450) 979-4373 Fax: (450) 979-4626 www.exmweb.com		Flatness Aplatissement Max 3.0mm
Customer Client Drawn By / Dessiné Par: BoxCad Material / Matière: 14 Ga Galvanized (1.7mm)		Projection  Date: 23-Jan-07
Color / Couleur: Unpainted Finish / Fini: Galvanized		Detail Rev.
Description: 880 SP0604G - Inner Panel		Part Number / Numéro Pièce: 880 SP0604G
Rev. 0		1 2

SEE BILL OF MATERIAL ON LAST PAGE

This drawing is confidential and must not be reproduced or used without the consent of EXM

Ce dessin est confidentiel et ne doit pas être reproduit ou utilisé sans le consentement de EXM

No.	Revisions	Date	By/Par

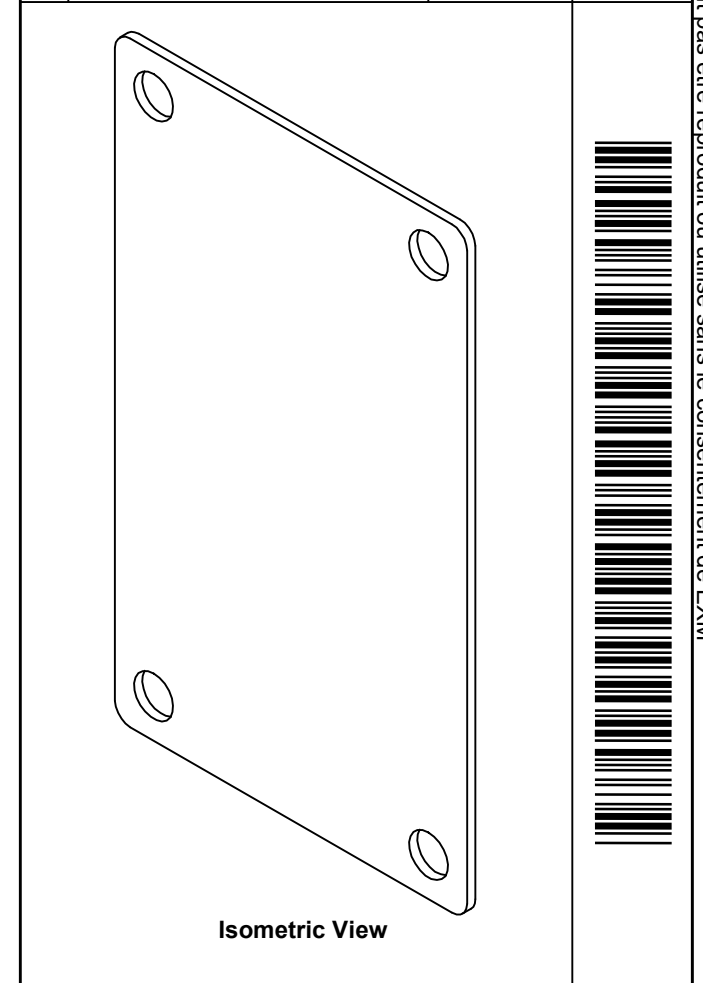

 Tél: (450) 979-4373 Fax: (450) 979-4626 www.exmweb.com		Flatness Aplatissement Max 3.0mm
Customer Client		Date
Drawn By / Dessiné Par: BoxCad		Date: 23-Jan-07
Material / Matière: 14 Ga Galvanized (1.7mm)		
Color / Couleur: Unpainted	Finish / Fini: Galvanized	
Description: 880 SP0604G - Inner Panel		Detail Rev.
Part Number / Numéro Pièce: 880 SP0604G		Rev. 0 / 2

Qty	Part Number	Rev	Description
1	880 SP0604G-P	0	880 SP0604G - Inner Panel Part
Parts List			