

This drawing is confidential and must not be reproduced or used without the consent of EXM

Ce dessin est confidentiel et ne doit pas être reproduit ou utilisé sans le consentement de EXM

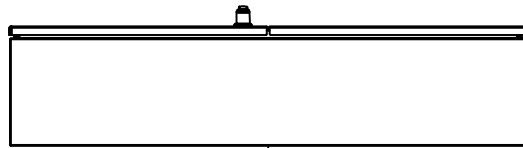

TOP



BACK

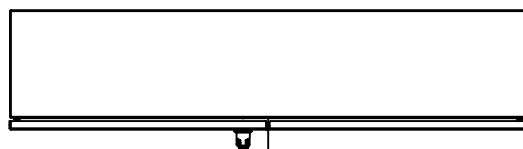

BOTTOM

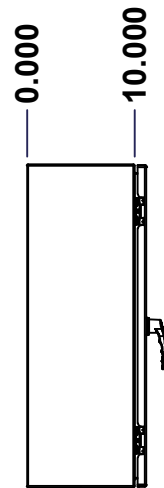

LEFT

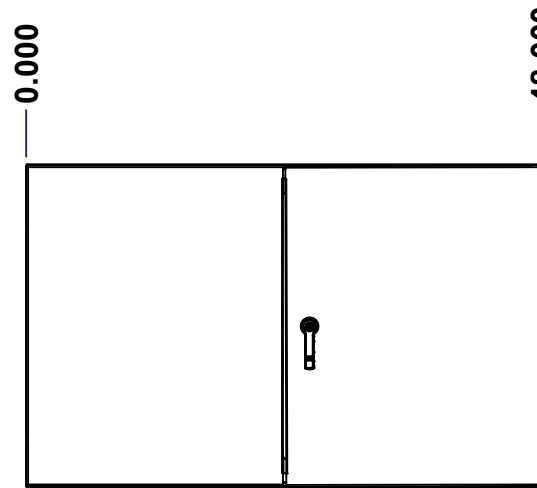

FRONT

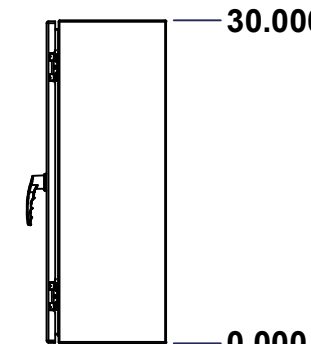

RIGHT

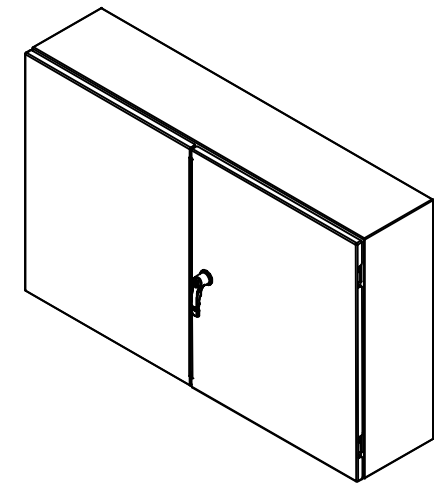

Isometric View



**GRAIN DIRECTION:
TOP/BOTTOM: HORIZONTAL
LEFT/RIGHT/BACK/FRONT: VERTICAL**

SEE BILL OF MATERIAL ON LAST PAGE

| No. | Revisions | Date | By/Par |
|-----|-----------|------|--------|
| | | | |
| | | | |
| | | | |
| | | | |

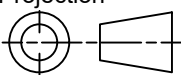
| | | |
|--|-----------------------------------|---|
|  Tél: (450) 979-4373 Fax: (450) 979-4626 www.exmweb.com | | Flatness Aplatissement Max 3.0mm Projection  |
| Customer Client | Date | |
| Drawn By Dessiné Par | BoxCad: BoxCad | Date 19-Apr-24 |
| Material Matière | 14 Ga Stainless Steel 304 (1.7mm) | |
| Color Couleur | Unpainted | Finish Fini Brushed |
| Description | Detail Rev. | |
| 5500ESSDD 30" x 48" x 10" Assembly | | |
| Part Number Numéro Pièce | Rev. | 1 |
| 5500ESSDD304810 | 0 | 13 |

This drawing is confidential and must not be reproduced or used without the consent of EXM

Ce dessin est confidentiel et ne doit pas être reproduit ou utilisé sans le consentement de EXM

| NOTE | |
|------|--|
| ITEM | DESCRIPTION |
| 1 | NEMA 12, 13 Enclosure (IP55) |
| 2 | C/W Standard ground studs on box and cover |
| 3 | W/O Standard door stiffener |
| 4 | C/W Standard inner panel (Included) |
| 5 | C/W Standard inner panel mounting studs |

| No. | Revisions | Date | By/Par |
|-----|-----------|------|--------|
| | | | |
| | | | |
| | | | |
| | | | |
| | | | |
| | | | |

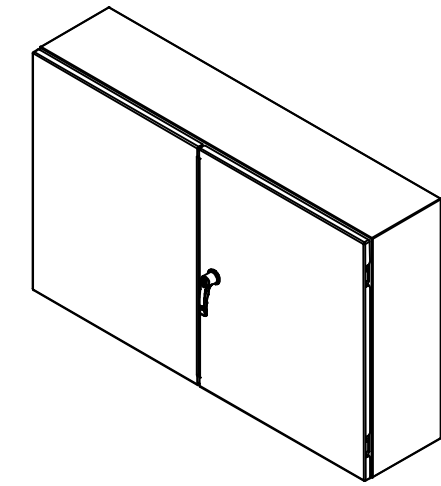

Isometric View

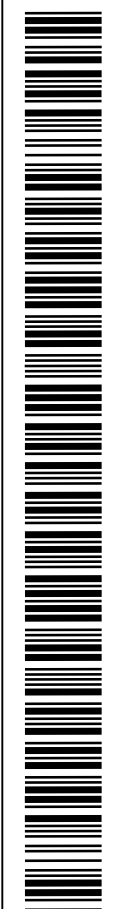

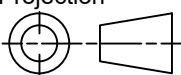
| | | |
|--|-----------------------------------|---|
|  Tél: (450) 979-4373 Fax: (450) 979-4626 www.exmweb.com | Flatness Aplatissement | Max 3.0mm |
| | Projection |  |
| Customer Client | Date | |
| Drawn By Dessiné Par | BoxCad: BoxCad | Date 19-Apr-24 |
| Material Matière | 14 Ga Stainless Steel 304 (1.7mm) | |
| Color Couleur | Unpainted | Finish Fini Brushed |
| Description | Detail Rev. | |
| 5500ESSDD 30" x 48" x 10" Assembly | | |
| Part Number Numéro Pièce | Rev. | 2 |
| 5500ESSDD304810 | 0 | 13 |

| PACKING | | |
|-----------------------|-----|--|
| ITEM | QTY | DESCRIPTION |
| Cardboard sleeve | 2 | Top and Bottom |
| Cardboard strip | 2 | Between back of enclosure and inner panel |
| Plastic bag | 1 | To protect cover surface and inside gasket |
| Plastic strap - Black | 2 | To Squeeze the 2 cardboard sleeve together |
| Packaging label | 1 | White label with product number |

| | | | |
|------------|-------------------|-----|--|
| 1 | 881 SP4830G | 0 | 881 SP - Inner Panel |
| 3 | STK-K-01320 | 0 | 5412 ES Inner Panel Accessory Kit |
| 1 | 5500ESSDD304810LD | 0 | 5500ESSDD 30" x 48" Lock Door |
| 1 | 5500ESSDD304810FD | 0 | 5500ESSDD 30" x 48" Flange Door |
| 1 | 5500ESSDD304810B | 0 | 5500ESSDD 30" x 48" x 10" Body |
| 4 | STK-Q-04051-08 | 1 | M6 x 8mm Stainless Steel Hexagon Socket Head Machine Screw with Nyseal |
| Qty | Part Number | Rev | Description |
| Parts List | | | |

This drawing is confidential and must not be reproduced or used without the consent of EXM

Ce dessin est confidentiel et ne doit pas être reproduit ou utilisé sans le consentement de EXM

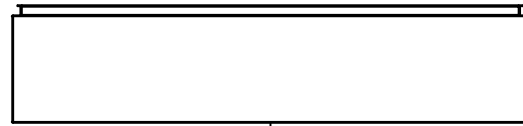

TOP

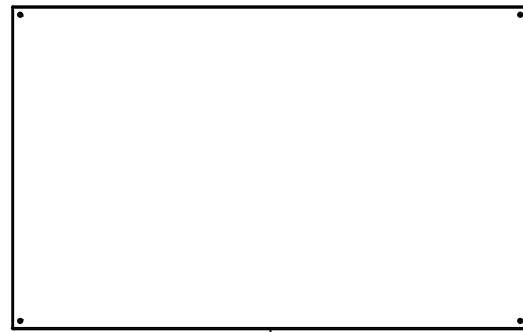

BACK

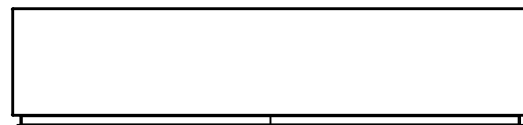

BOTTOM

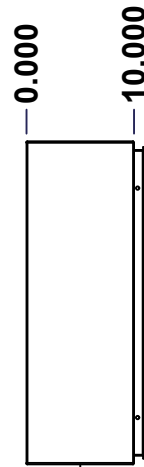

LEFT

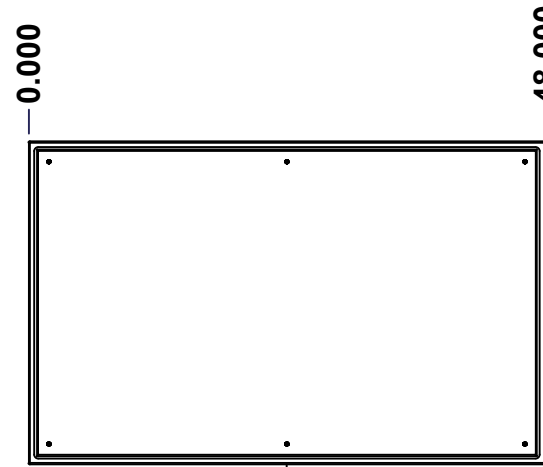

FRONT

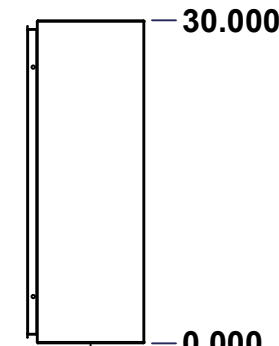

RIGHT

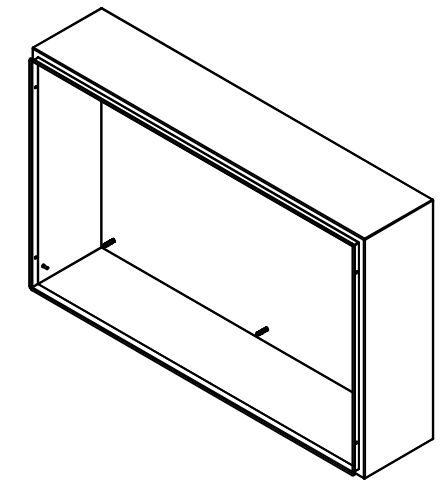

Isometric View

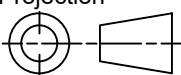

| No. | Revisions | Date | By/Par |
|-----|-----------|------|--------|
| | | | |
| | | | |
| | | | |
| | | | |

| | | |
|--|-----------------------------------|---|
|  Tél: (450) 979-4373 Fax: (450) 979-4626 www.exmweb.com | | Flatness Aplatissement Max 3.0mm Projection  |
| Customer Client | Date | |
| Drawn By Dessiné Par | BoxCad: BoxCad | Date 19-Apr-24 |
| Material Matière | 14 Ga Stainless Steel 304 (1.7mm) | |
| Color Couleur | Unpainted | Finish Fini Brushed |
| Description | Detail Rev. | |
| 5500ESSDD 30" x 48" x 10" Body | | |
| Part Number Numéro Pièce | Rev. | 3 |
| 5500ESSDD304810B | 0 | 13 |

SEE BILL OF MATERIAL ON LAST PAGE

This drawing is confidential and must not be reproduced or used without the consent of EXM

Ce dessin est confidentiel et ne doit pas être reproduit ou utilisé sans le consentement de EXM

| STANDARD FEATURES ARE NOT LISTED IN THIS HOLE TABLE | | | |
|--|-------|-------|-----------------------------|
| HOLE TABLE - RIGHT VIEW (CUSTOM FEATURE ONLY) | | | |
| CUT-OUT | XDIM | YDIM | DESCRIPTION |
| 1 | 8.500 | 2.000 | GND STUD M6 x 16mm (Inside) |

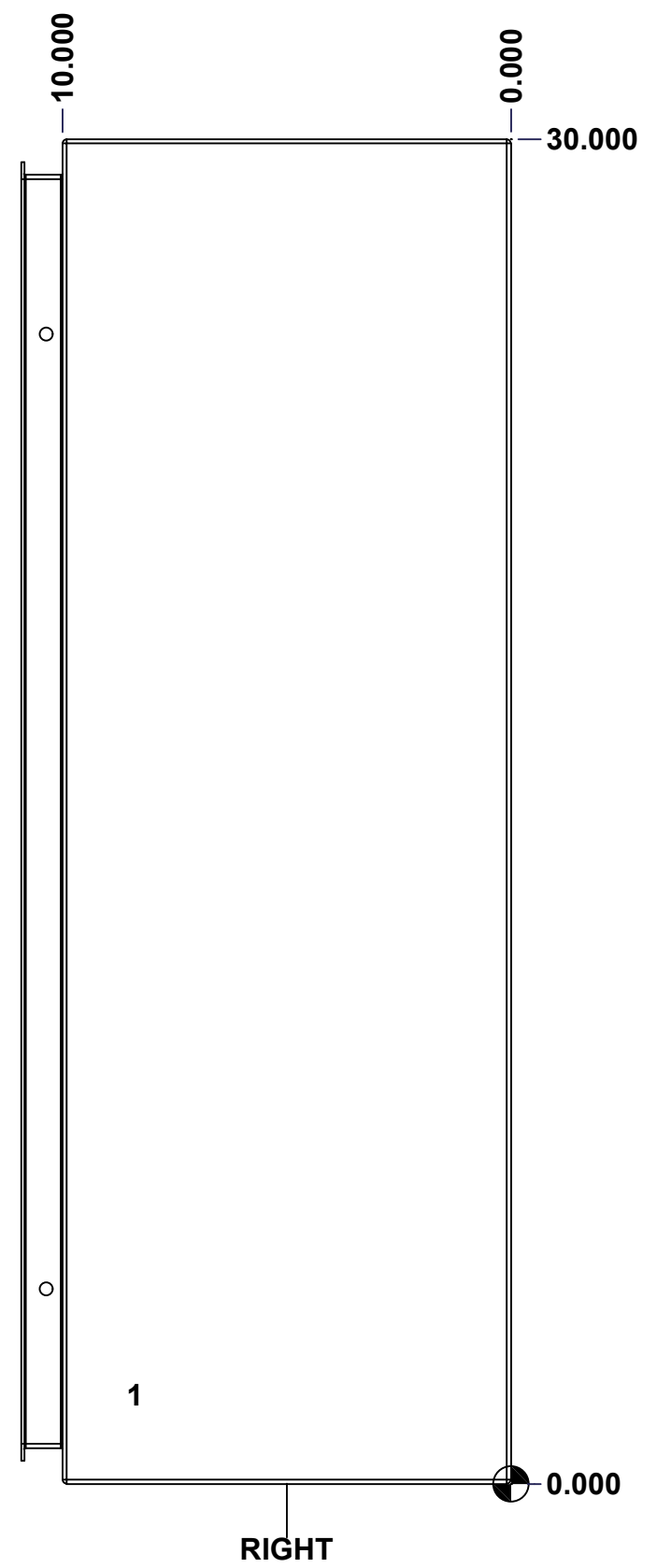

| | | | |
|--|--------------------------------|----------|----|
| | Description | Status | |
| | 5500ESSDD 30" x 48" x 10" Body | (NULL) | |
| | Part Number Numéro Pièce | Rev. | 4 |
| | 5500ESSDD304810B | 0 | 13 |

This drawing is confidential and must not be reproduced or used without the consent of EXM

Ce dessin est confidentiel et ne doit pas être reproduit ou utilisé sans le consentement de EXM

STANDARD FEATURES ARE NOT LISTED IN THIS HOLE TABLE

HOLE TABLE - LEFT VIEW (CUSTOM FEATURE ONLY)

| CUT-OUT | XDIM | YDIM | DESCRIPTION |
|---------|-------|-------|-----------------------------|
| 1 | 8.500 | 2.000 | GND STUD M6 x 16mm (Inside) |

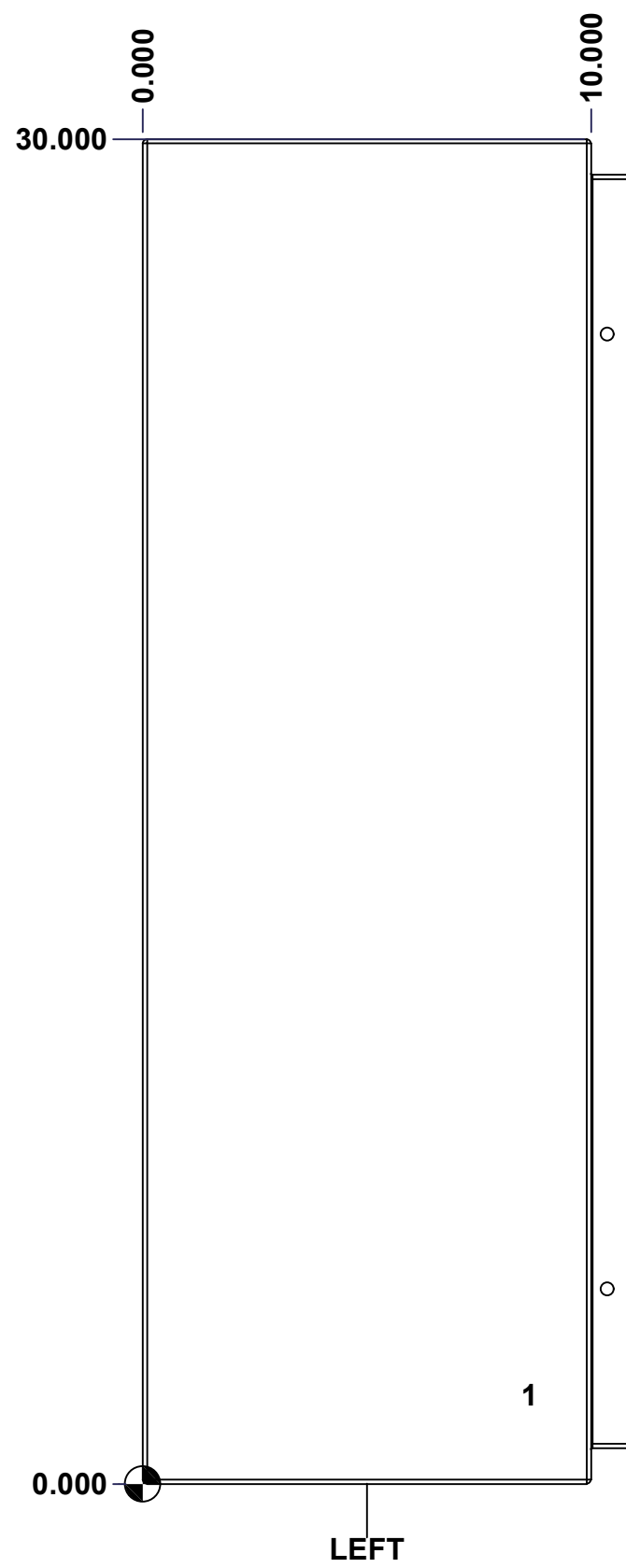

| | | |
|--|--------------------------------|--------|
| | Description | Status |
| | 5500ESSDD 30" x 48" x 10" Body | (NULL) |
| Part Number Numéro Pièce 5500ESSDD304810B | Rev. | 5 |
| | 0 | 13 |

This drawing is confidential and must not be reproduced or used without the consent of EXM

Ce dessin est confidentiel et ne doit pas être reproduit ou utilisé sans le consentement de EXM

STANDARD FEATURES ARE NOT LISTED IN THIS HOLE TABLE

HOLE TABLE - BACK VIEW (CUSTOM FEATURE ONLY)

| CUT-OUT | XDIM | YDIM | DESCRIPTION |
|---------|--------|--------|----------------------------|
| 1 | 1.875 | 1.875 | IP STUD M8 x 35mm (Inside) |
| 2 | 1.875 | 28.125 | IP STUD M8 x 35mm (Inside) |
| 3 | 46.125 | 28.125 | IP STUD M8 x 35mm (Inside) |
| 4 | 46.125 | 1.875 | IP STUD M8 x 35mm (Inside) |
| 5 | 24.000 | 1.875 | IP STUD M8 x 35mm (Inside) |
| 6 | 24.000 | 28.125 | IP STUD M8 x 35mm (Inside) |
| ----- | | | |
| 7 | 47.250 | 0.750 | RND Ø0.390 |
| 8 | 47.250 | 29.250 | RND Ø0.390 |
| 9 | 0.750 | 29.250 | RND Ø0.390 |
| 10 | 0.750 | 0.750 | RND Ø0.390 |

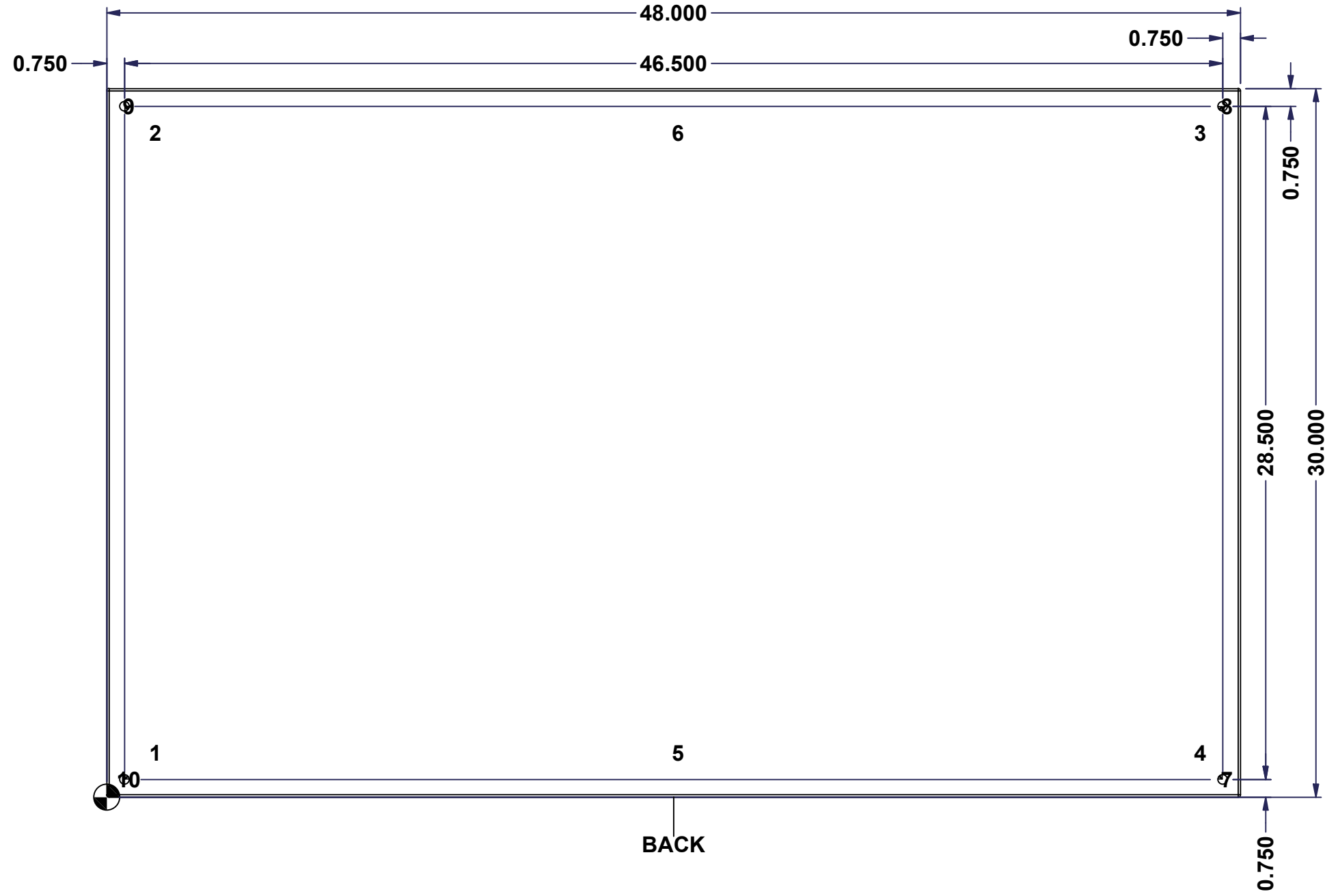

BACK

| | | |
|--|--------------------------------|----------|
| | Description | Status |
| | 5500ESSDD 30" x 48" x 10" Body | (NULL) |
| | Part Number | Rev. |
| | Numéro Pièce | 6 |
| | 5500ESSDD304810B | 0 |
| | | 13 |

This drawing is confidential and must not be reproduced or used without the consent of EXM

Ce dessin est confidentiel et ne doit pas être reproduit ou utilisé sans le consentement de EXM

| No. | Revisions | Date | By/Par |
|-----|-----------|------|--------|
| | | | |
| | | | |
| | | | |
| | | | |
| | | | |

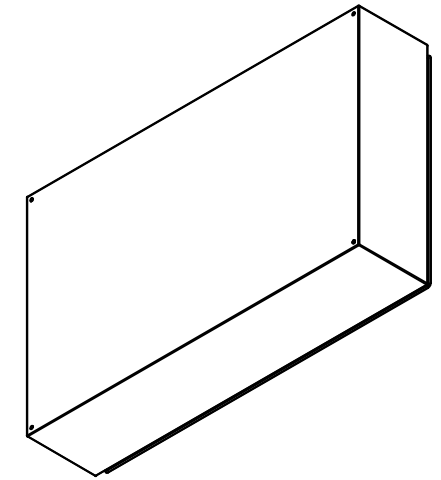

Isometric View

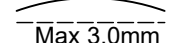

| | | |
|--|------------------------|--|
|  Tél: (450) 979-4373 Fax: (450) 979-4626 www.exmweb.com | | Flatness Aplatissement  Max 3.0mm |
| Customer Client | | Date |
| Drawn By Dessiné Par BoxCad: BoxCad | | Date 19-Apr-24 |
| Material Matière 14 Ga Stainless Steel 304 (1.7mm) | | |
| Color Couleur Unpainted | Finish Fini Brushed | |
| Description 5500ESSDD 30" x 48" x 10" Body | | Detail Rev. |
| Part Number Numéro Pièce 5500ESSDD304810B | | Rev. 7 0 |

| Qty | Part Number | Rev | Description |
|------------|--------------------|-----|---------------------------------------|
| 2 | STK-Q-16085 | 0 | Ground Stud M6 x 16mm Stainless Steel |
| 6 | STK-Q-16020 | 1 | Stud M8 x 35mm Stainless Steel |
| 1 | 5500ESSDD304810B-P | 0 | 5500ESSDD 30" x 48" x 10" Body Part |
| Parts List | | | |

This drawing is confidential and must not be reproduced or used without the consent of EXM

Ce dessin est confidentiel et ne doit pas être reproduit ou utilisé sans le consentement de EXM

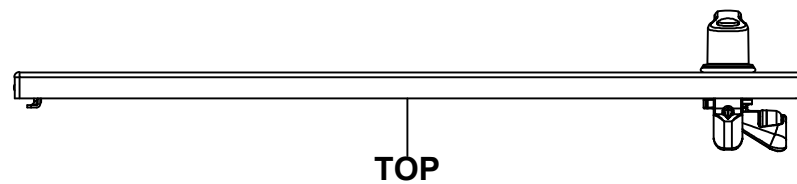

TOP

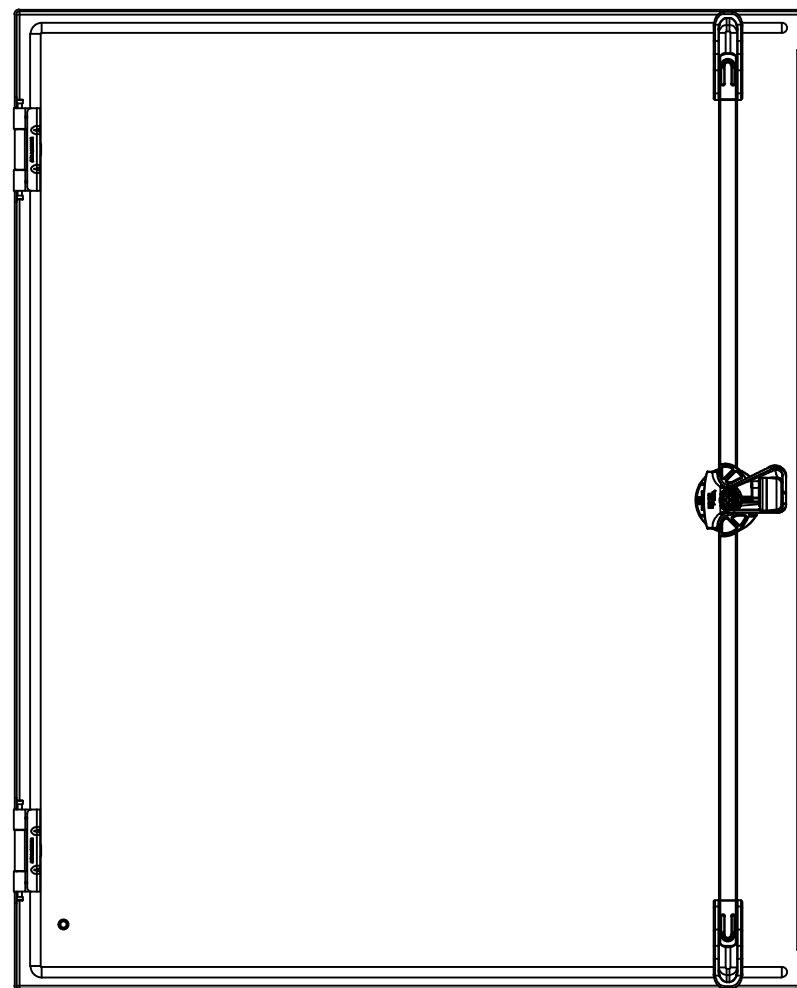

BACK

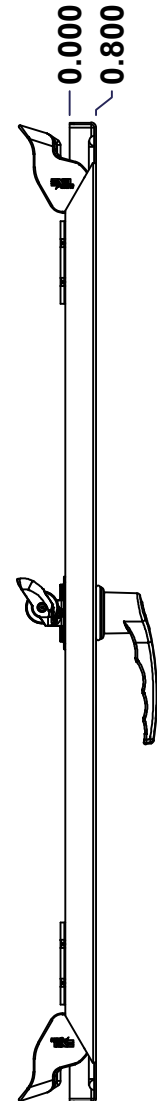

LEFT

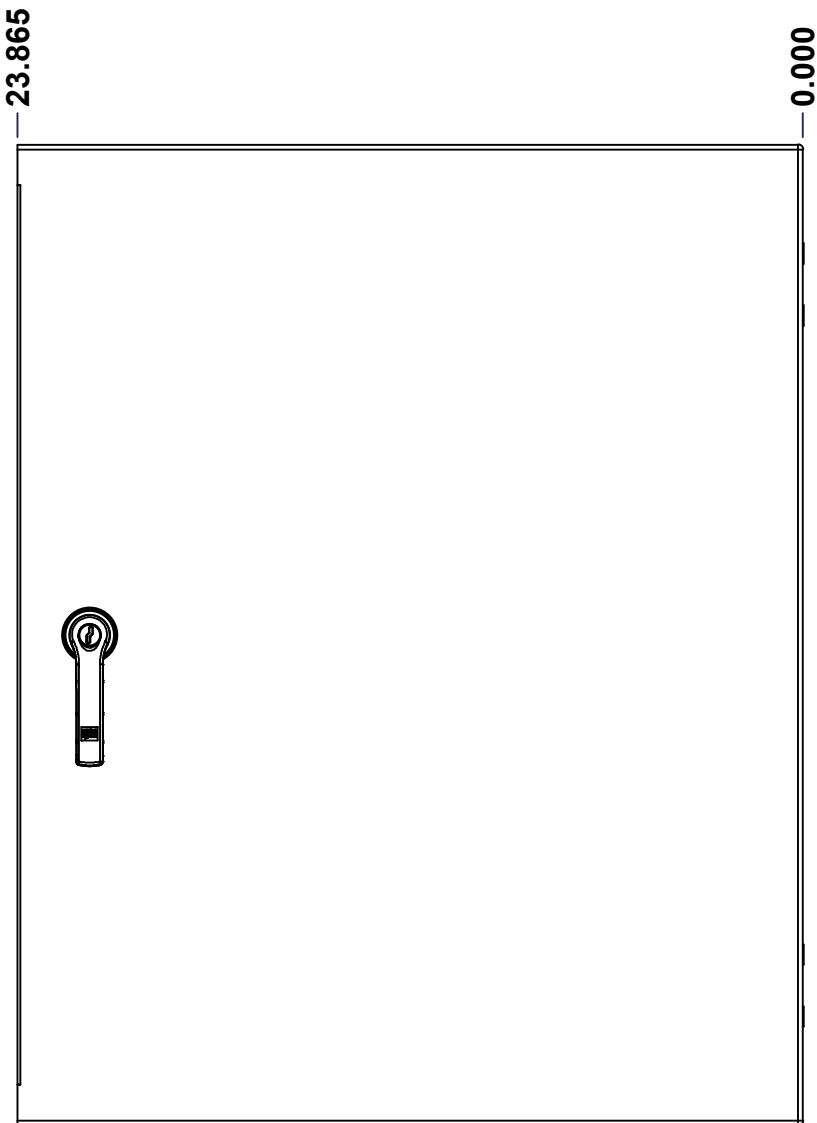

FRONT

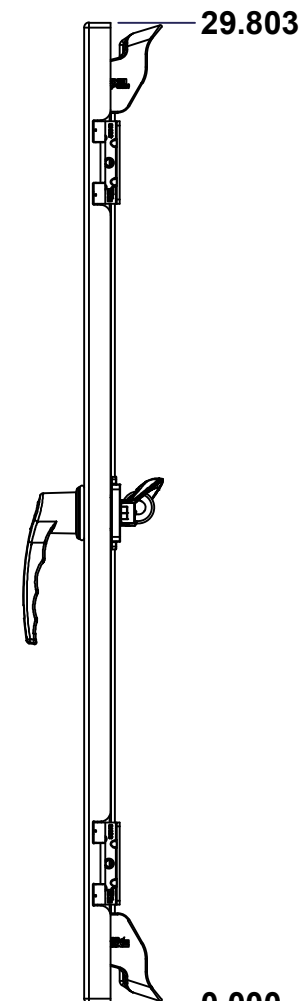

RIGHT



BOTTOM

| No. | Revisions | Date | By/Par |
|-----|-----------|------|--------|
| | | | |
| | | | |
| | | | |
| | | | |

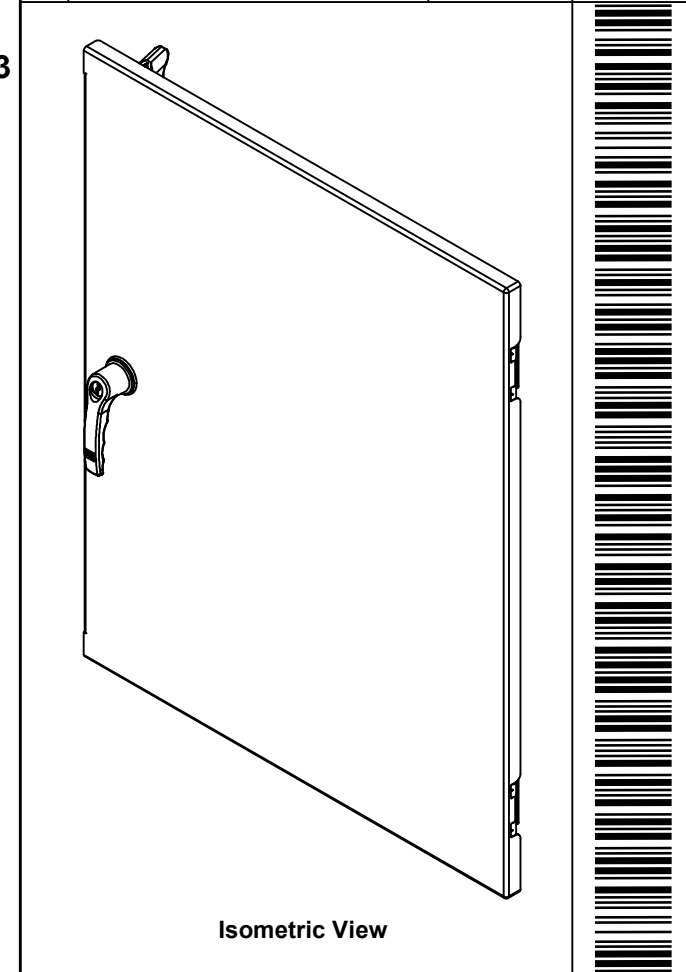

Isometric View

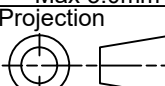
| | | |
|--|-----------------------------------|---|
|  Tél: (450) 979-4373 Fax: (450) 979-4626 www.exmweb.com | | Flatness Aplatissement Max 3.0mm Projection  |
| Customer Client | Date | |
| Drawn By Dessiné Par | BoxCad: BoxCad | Date 19-Apr-24 |
| Material Matière | 16 Ga Stainless Steel 304 (1.4mm) | |
| Color Couleur | Unpainted | Finish Fini Brushed |
| Description | Detail Rev. | |
| 5500ESSDD 30" x 48" Lock Door | | |
| Part Number Numéro Pièce | Rev. | 8 |
| 5500ESSDD304810LD | 0 | 13 |

SEE BILL OF MATERIAL ON LAST PAGE

This drawing is confidential and must not be reproduced or used without the consent of EXM

Ce dessin est confidentiel et ne doit pas être reproduit ou utilisé sans le consentement de EXM

STANDARD FEATURES ARE NOT LISTED IN THIS HOLE TABLE

HOLE TABLE - FRONT VIEW (CUSTOM FEATURE ONLY)

| CUT-OUT | XDIM | YDIM | DESCRIPTION |
|---------|--------|--------|-----------------------------|
| 1 | 21.678 | 24.896 | CLOSING BAR STUD (Inside) |
| 2 | 21.678 | 4.907 | CLOSING BAR STUD (Inside) |
| ----- | ----- | ----- | ----- |
| 3 | 1.486 | 2.000 | GND STUD M6 x 16mm (Inside) |
| 4 | 21.678 | 14.902 | HANDLE 885 ESL2A-LSS @ 0.0° |

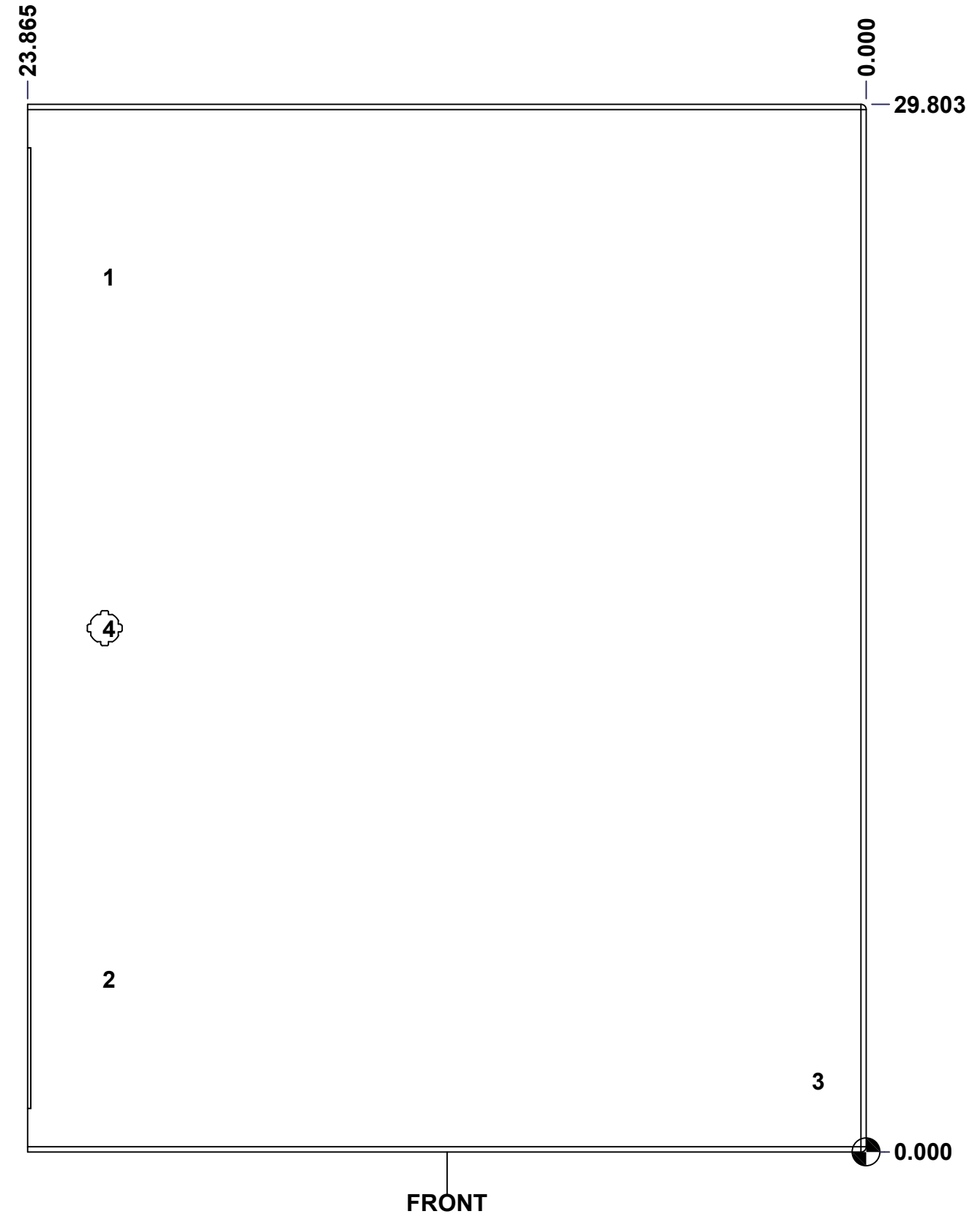

FRONT

| | | |
|--|-------------------------------|----------|
| | Description | Status |
| | 5500ESSDD 30" x 48" Lock Door | (NULL) |
| | Part Number Numéro Pièce | Rev. |
| | 5500ESSDD304810LD | 0 |
| | | 9 |
| | | 13 |

This drawing is confidential and must not be reproduced or used without the consent of EXM

Ce dessin est confidentiel et ne doit pas être reproduit ou utilisé sans le consentement de EXM

| No. | Revisions | Date | By/Par |
|-----|-----------|------|--------|
| | | | |
| | | | |
| | | | |
| | | | |
| | | | |

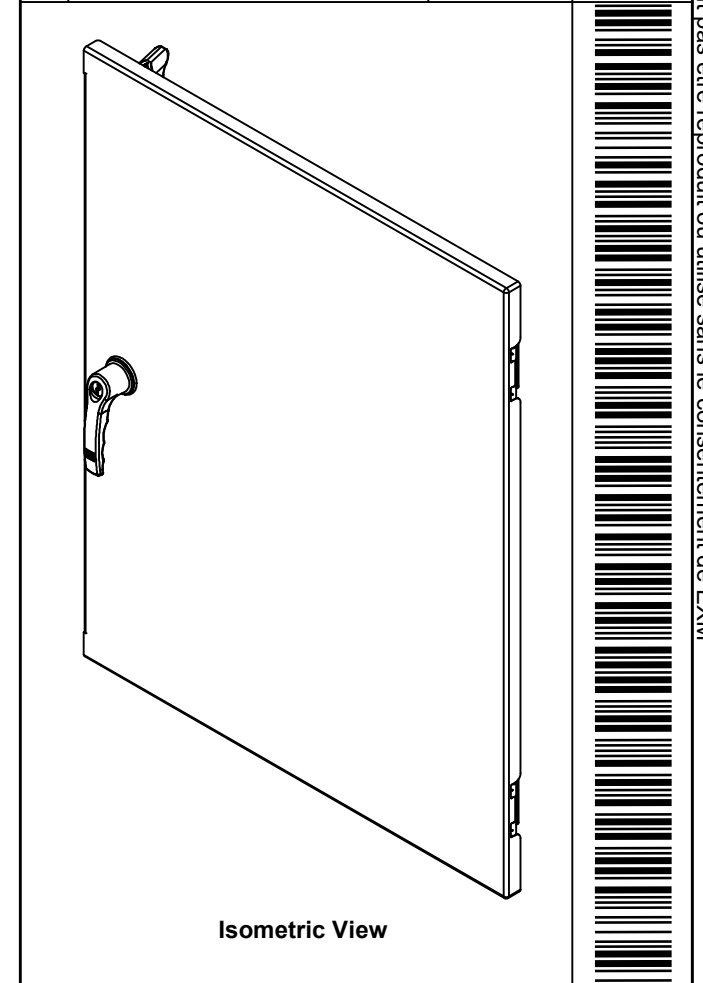



Tél: (450) 979-4373
Fax: (450) 979-4626
www.exmweb.com

Flatness
Aplatissement
Max 3.0mm

Projection



| | | | |
|---|---------------------|----|--|
| 2 | STK-Q-90042 | 4 | 5412 ES - Cabinet Closing Bar End (Small) |
| 2 | STK-Q-45657-30 | 0 | 5412 ESS - Stainless Steel Closing Bar |
| 1 | STK-A-50535 | 15 | 5412 ES Handle Cam Assembly (Left Side, Grip 32mm) |
| 1 | STK-Q-90051 | 3 | 5412 ES - Handle Cam Spacer |
| 1 | 885 ESL2A-LSS | 3 | 5412 ESS Key Lock L-Handle (3 Pts) |
| 1 | STK-Q-16085 | 0 | Ground Stud M6 x 16mm Stainless Steel |
| 2 | STK-Q-16407 | 2 | Guide Stud - Small (No Paint Cap Required) |
| 1 | 5500ESSDD304810LD-G | 0 | 5500ESSDD 30" x 48" Lock Door Gasket |
| 1 | 5500ESSDD304810LD-P | 0 | 5500ESSDD 30" x 48" Lock Door |
| 2 | STK-A-33016 | 0 | 5412 ESS Bended Hinge (Body Part) |

| | |
|-------------------------------|-------------------------------------|
| Customer Client | Date |
| Drawn By Dessiné Par | BoxCad: BoxCad Date 19-Apr-24 |
| Material Matière | 16 Ga Stainless Steel 304 (1.4mm) |
| Color Couleur | Unpainted Finish Fini Brushed |
| Description | Detail Rev. |
| 5500ESSDD 30" x 48" Lock Door | |
| Part Number Numéro Pièce | Rev. 10 |
| 5500ESSDD304810LD | 0 13 |

| QTY | Part Number | Rev | Description |
|------------|-------------|-----|-------------|
| Parts List | | | |

This drawing is confidential and must not be reproduced or used without the consent of EXM

Ce dessin est confidentiel et ne doit pas être reproduit ou utilisé sans le consentement de EXM

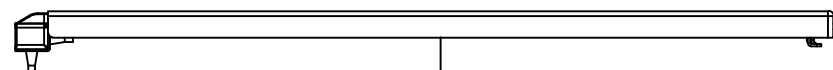

TOP

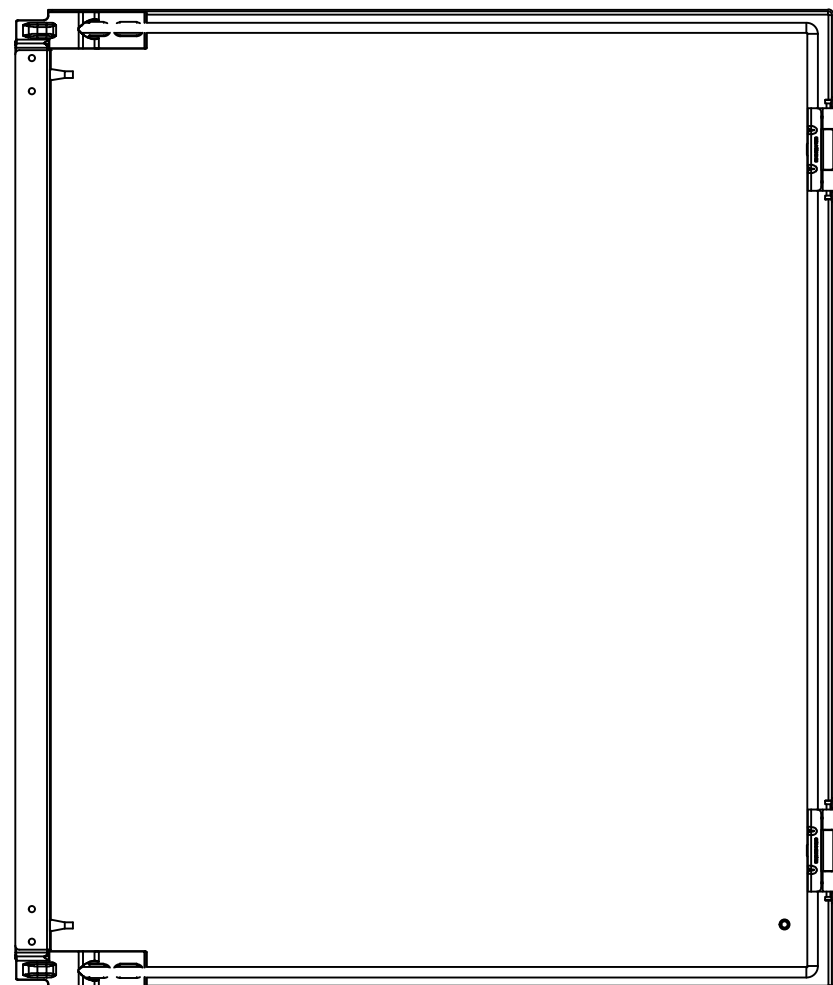

BACK

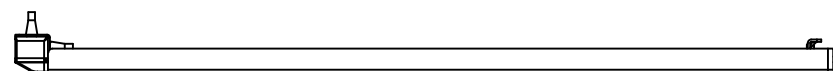

BOTTOM

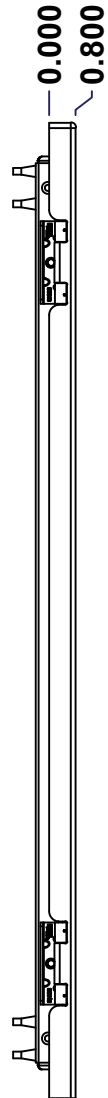

LEFT

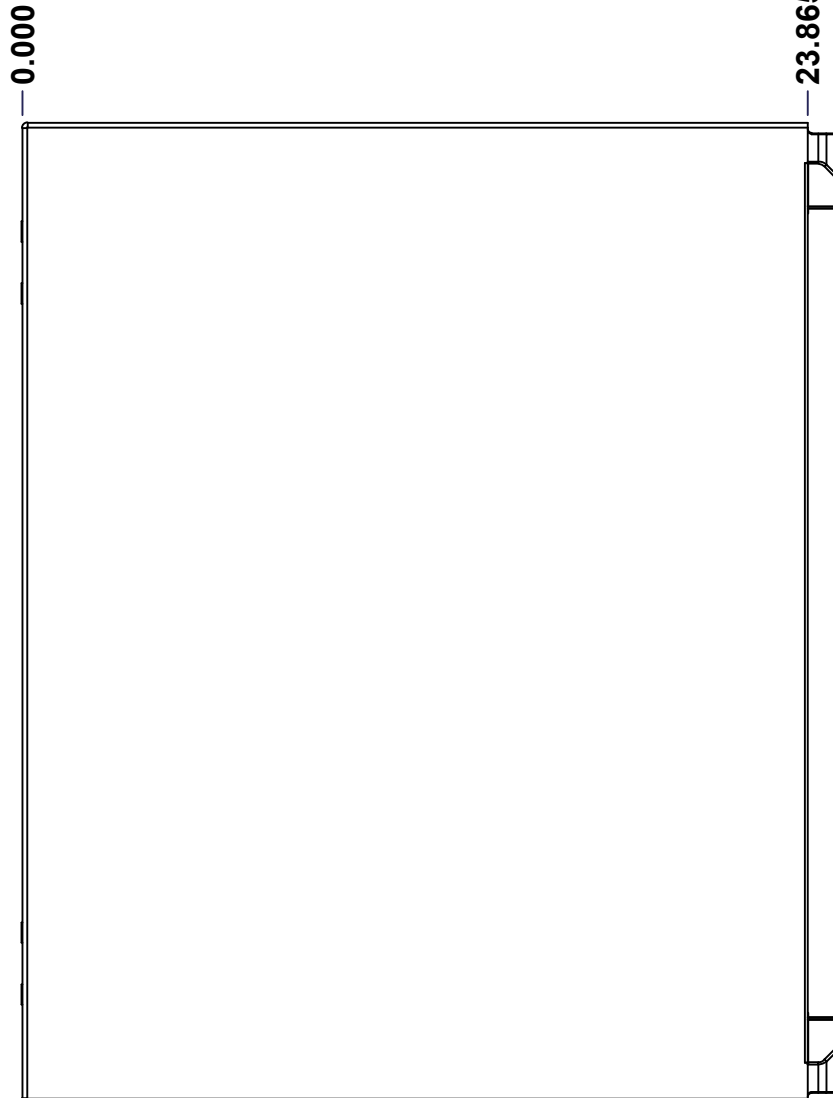

FRONT

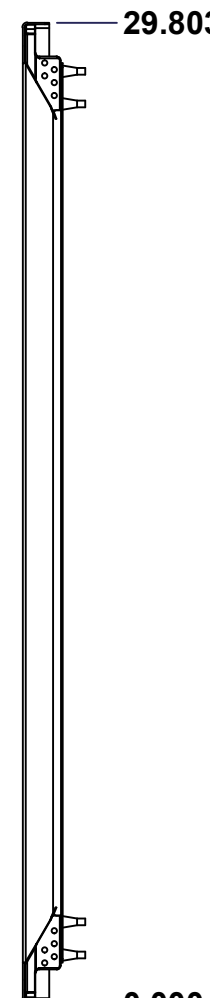

RIGHT

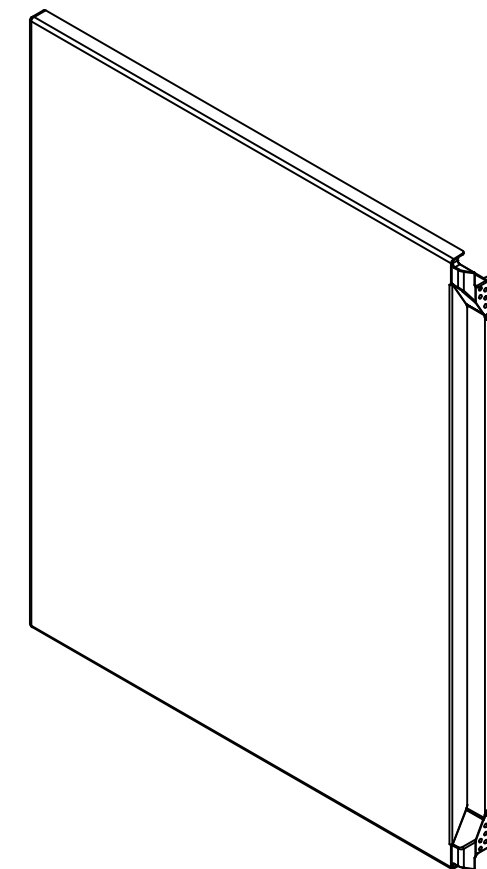

Isometric View

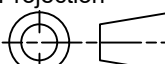

| No. | Revisions | Date | By/Par |
|-----|-----------|------|--------|
| | | | |
| | | | |
| | | | |
| | | | |
| | | | |

| | | |
|--|-----------------------------------|---|
|  Tél: (450) 979-4373 Fax: (450) 979-4626 www.exmweb.com | | Flatness Aplatissement Max 3.0mm Projection  |
| Customer Client | Date | |
| Drawn By Dessiné Par | BoxCad: BoxCad | Date 19-Apr-24 |
| Material Matière | 16 Ga Stainless Steel 304 (1.4mm) | |
| Color Couleur | Unpainted | Finish Fini Brushed |
| Description | Detail Rev. | |
| 5500ESSDD 30" x 48" Flange Door | | |
| Part Number Numéro Pièce | Rev. | 11 |
| 5500ESSDD304810FD | 0 | 13 |

SEE BILL OF MATERIAL ON LAST PAGE

This drawing is confidential and must not be reproduced or used without the consent of EXM

Ce dessin est confidentiel et ne doit pas être reproduit ou utilisé sans le consentement de EXM

STANDARD FEATURES ARE NOT LISTED IN THIS HOLE TABLE

HOLE TABLE - FRONT VIEW (CUSTOM FEATURE ONLY)

| CUT-OUT | XDIM | YDIM | DESCRIPTION |
|---------|-------|-------|-----------------------------|
| 1 | 1.486 | 2.000 | GND STUD M6 x 16mm (Inside) |

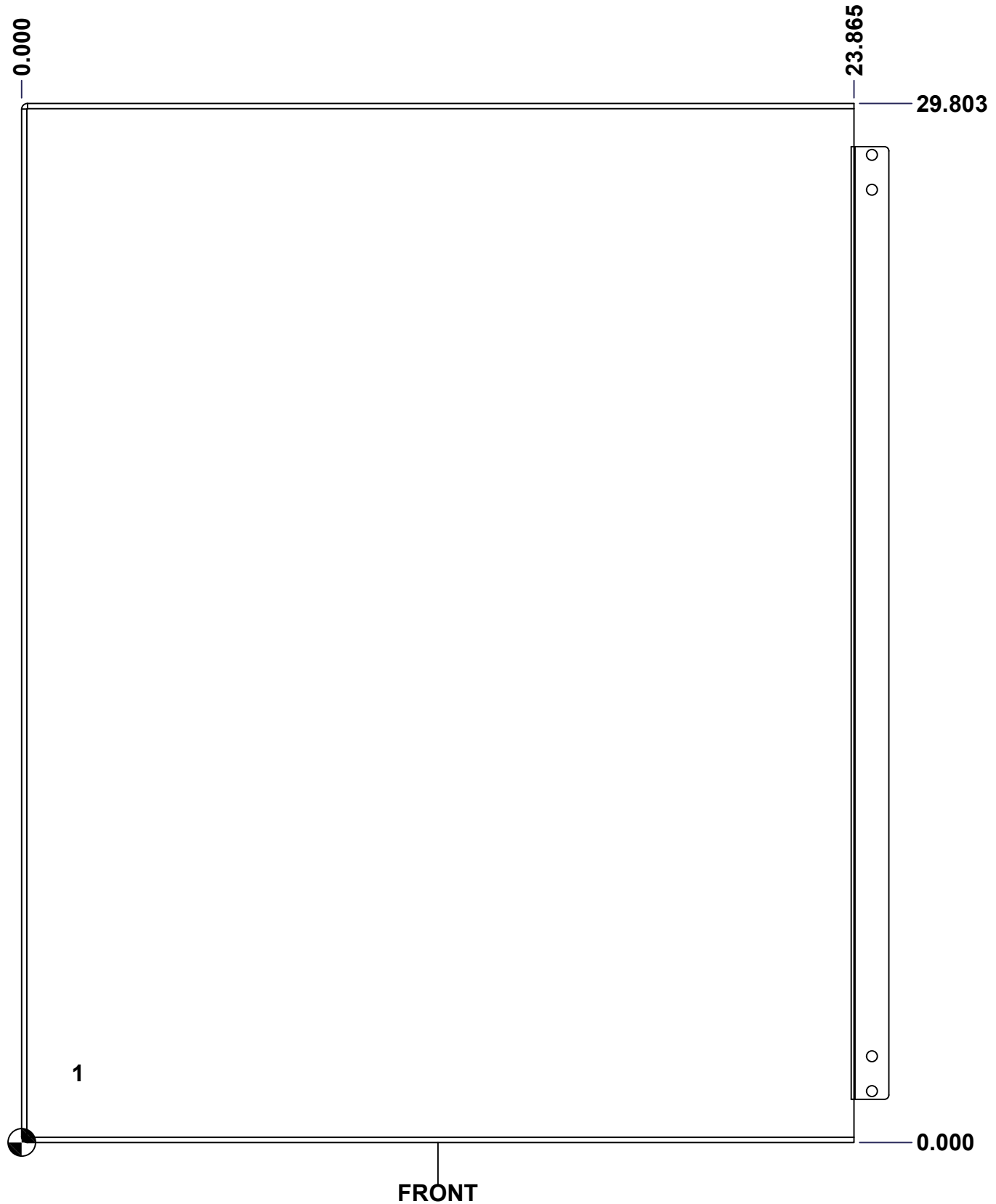

| | | |
|---|---------------------------------|--------|
| | Description | Status |
| | 5500ESSDD 30" x 48" Flange Door | (NULL) |
| Part Number Numéro Pièce 5500ESSDD304810FD | Rev. | 12 |
| | 0 | 13 |

This drawing is confidential and must not be reproduced or used without the consent of EXM

Ce dessin est confidentiel et ne doit pas être reproduit ou utilisé sans le consentement de EXM

| No. | Revisions | Date | By/Par |
|-----|-----------|------|--------|
| | | | |
| | | | |
| | | | |
| | | | |
| | | | |

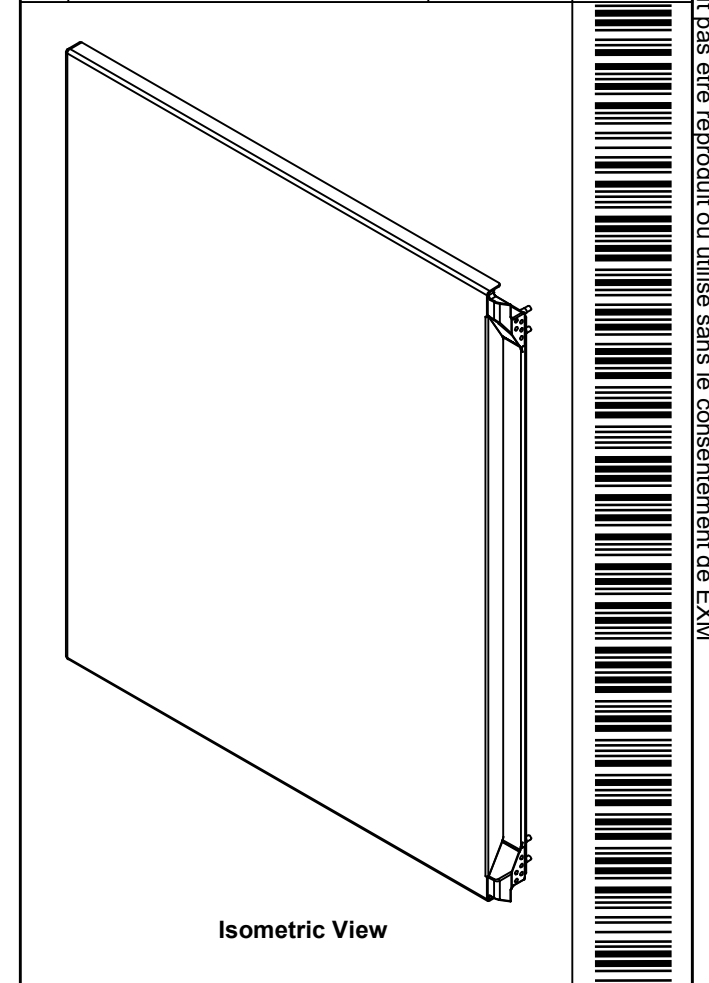

| | | |
|--|------------------------|---------------------------|
| Tél: (450) 979-4373 Fax: (450) 979-4626 www.exmweb.com | | Flatness Aplatissement |
| | | Max 3.0mm |
| Projection | | Date |
| Customer Client | | Date 19-Apr-24 |
| Drawn By / Dessiné Par: BoxCad: BoxCad | | |
| Material / Matière: 16 Ga Stainless Steel 304 (1.4mm) | | |
| Color / Couleur: Unpainted | Finish / Fini: Brushed | |
| Description: 5500ESSDD 30" x 48" Flange Door | | Detail Rev. |
| Part Number / Numéro Pièce: 5500ESSDD304810FD | | Rev. 0 |
| | | 13 |

| QTY | Part Number | Rev | Description |
|------------|---------------------|-----|---|
| 1 | STK-Q-16085 | 0 | Ground Stud M6 x 16mm Stainless Steel |
| 1 | STK-G-00701 | 0 | 1" x 1/4" Self-Adhesive Neoprene Gasket |
| 1 | STK-G-03200 | 8 | 5500 ESDD Lower Flange Door Gasket |
| 1 | STK-G-03100 | 8 | 5500 ESDD Upper Flange Door Gasket |
| 1 | 5500ESSDD304810FD-G | 0 | 5500ESSDD 30" x 48" Flange Door Gasket |
| 1 | 5500ESSDD304810FD-P | 0 | 5500ESSDD 30" x 48" Flange Door Part |
| 2 | STK-A-33016 | 0 | 5412 ESS Bended Hinge (Body Part) |
| Parts List | | | |

This drawing is confidential and must not be reproduced or used without the consent of EXM

Ce dessin est confidentiel et ne doit pas être reproduit ou utilisé sans le consentement de EXM

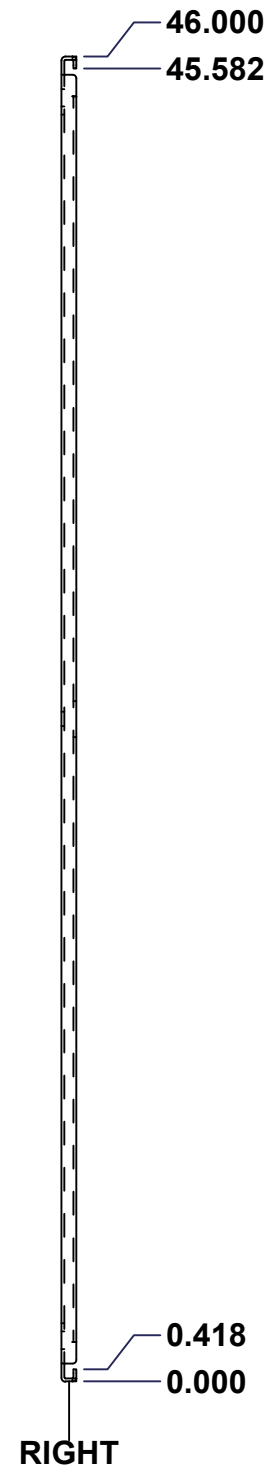
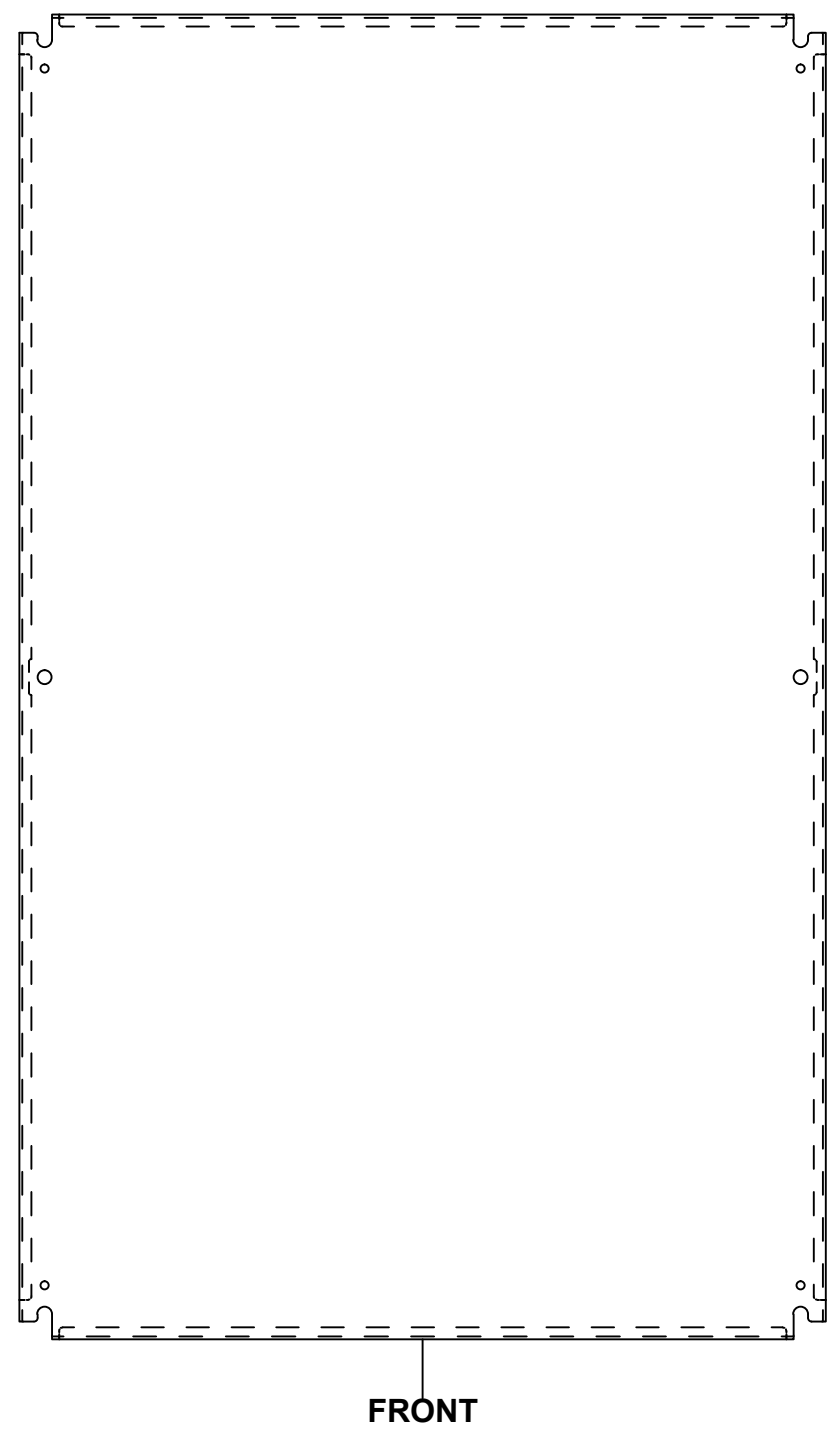
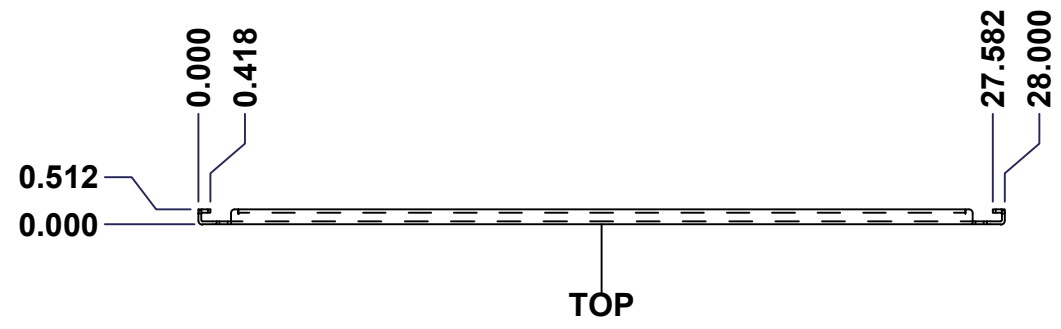

| No. | Revisions | Date | By/Par |
|-----|-----------|------|--------|
| | | | |
| | | | |
| | | | |
| | | | |
| | | | |

Isometric View

| | |
|--|--|
| Tél: (450) 979-4373 Fax: (450) 979-4626 www.exmweb.com | Flatness Aplatissement Max 3.0mm |
| | Projection |
| Customer Client | Date |
| Drawn By / Dessiné Par: BoxCad | Date: 23-Jan-07 |
| Material / Matière: See Part List | |
| Color / Couleur: See Part List | Finish / Fini: See Part List |
| Description: 881 SP - Inner Panel | |
| Detail Rev. | |
| Part Number / Numéro Pièce: 881 SP4830G | Rev. 0 |

| Qty | Part Number | Rev | Description | Material | Color | Finish |
|-----|---------------|-----|---------------------------|------------------|-----------|------------|
| 1 | 881 SP4830G-P | 0 | 881 SP - Inner Panel Part | 12 Ga Galvanized | Unpainted | Galvanized |

Parts List

This drawing is confidential and must not be reproduced or used without the consent of EXM

Ce dessin est confidentiel et ne doit pas être reproduit ou utilisé sans le consentement de EXM

| Table 1 | | | FRONT VIEW |
|---------|--------|--------|----------------------------|
| CUT-OUT | XDIM | YDIM | DESCRIPTION |
| 1 | 0.875 | 1.875 | GROUND HOLE (RND Ø0.290) |
| 2 | 27.125 | 1.875 | GROUND HOLE (RND Ø0.290) |
| 3 | 0.875 | 44.125 | GROUND HOLE (RND Ø0.290) |
| 4 | 27.125 | 44.125 | GROUND HOLE (RND Ø0.290) |
| 5 | 0.875 | 23.000 | MTG STUD HOLE (RND Ø0.500) |
| 6 | 27.125 | 23.000 | MTG STUD HOLE (RND Ø0.500) |

All knockouts are actual size / Les disques défonçables sont grandeur réel

| No. | Revisions | Date | By/Par |
|-----|-----------|------|--------|
| | | | |
| | | | |
| | | | |
| | | | |
| | | | |
| | | | |

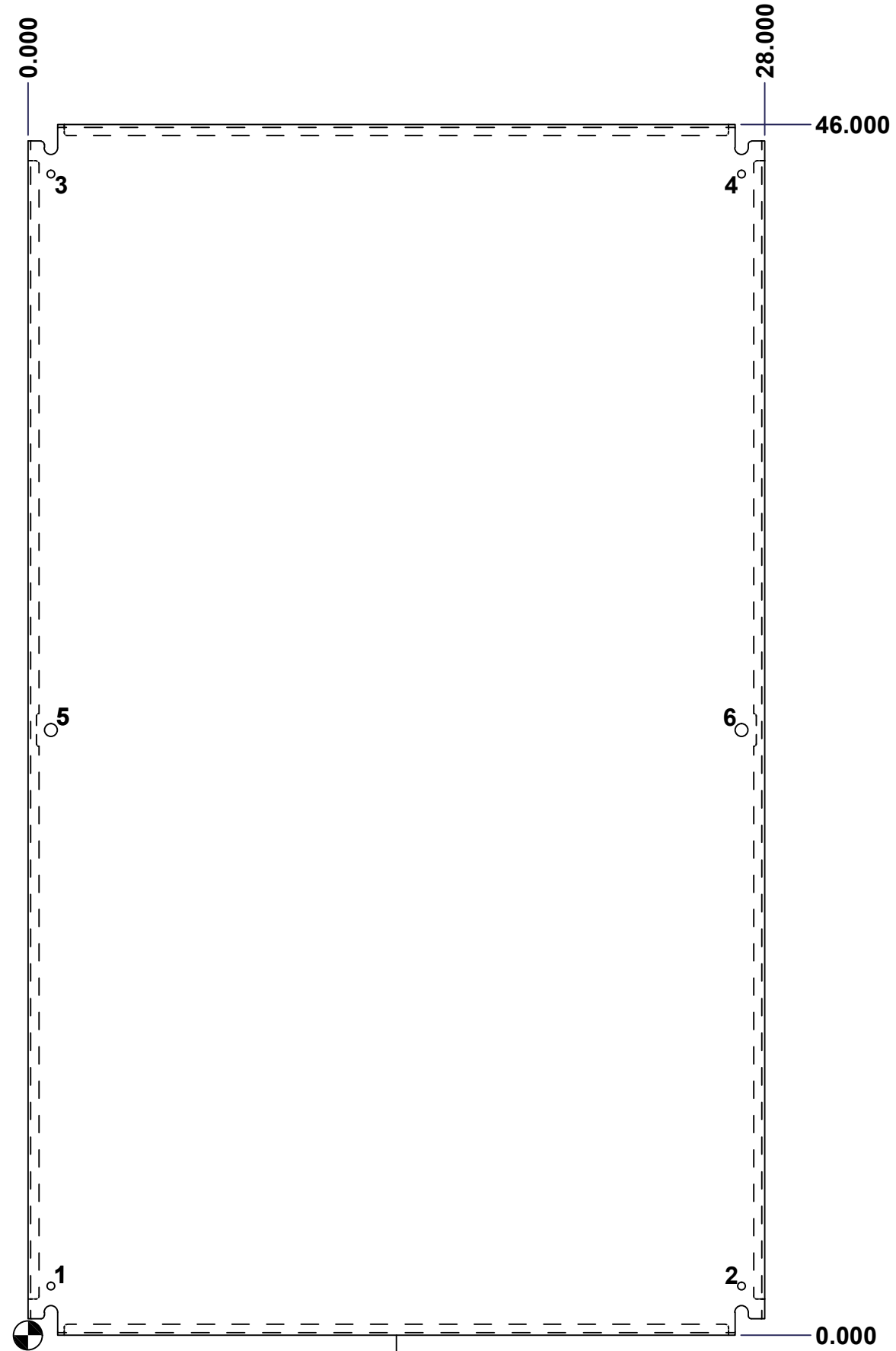

Isometric View

| | | |
|---|--|---------------------------|
| <p>Tél: (450) 979-4373 Fax: (450) 979-4626 www.exmweb.com</p> | | Flatness Aplatissement |
| | | Max 3.0mm |
| Customer Client Drawn By / Dessiné Par: BoxCad Material / Matière: See Part List Color / Couleur: See Part List Finish / Fini: See Part List Description: 881 SP - Inner Panel Part Number / Numéro Pièce: 881 SP4830G | | Projection |
| | | Date: 23-Jan-07 |
| Detail Rev. | | Rev. 2 |
| | | 0 |