

This drawing is confidential and must not be reproduced or used without the consent of EXM

Ce dessin est confidentiel et ne doit pas être reproduit ou utilisé sans le consentement de EXM

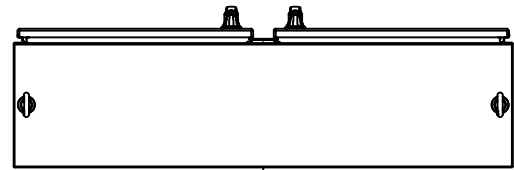

TOP

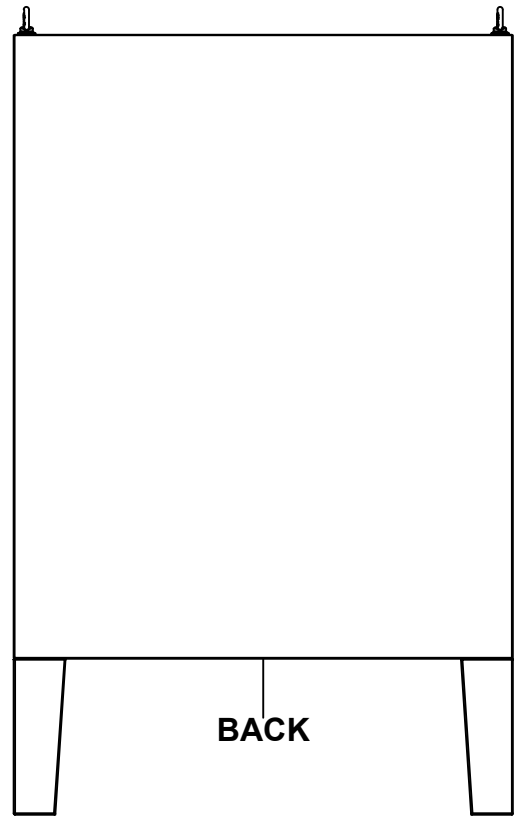

BACK

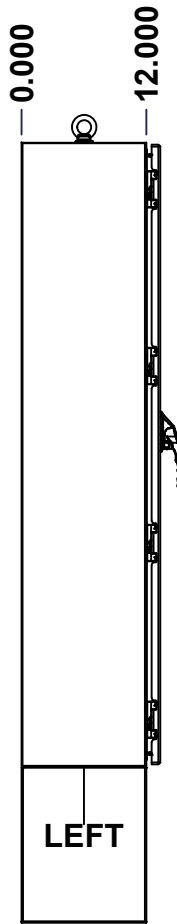

LEFT

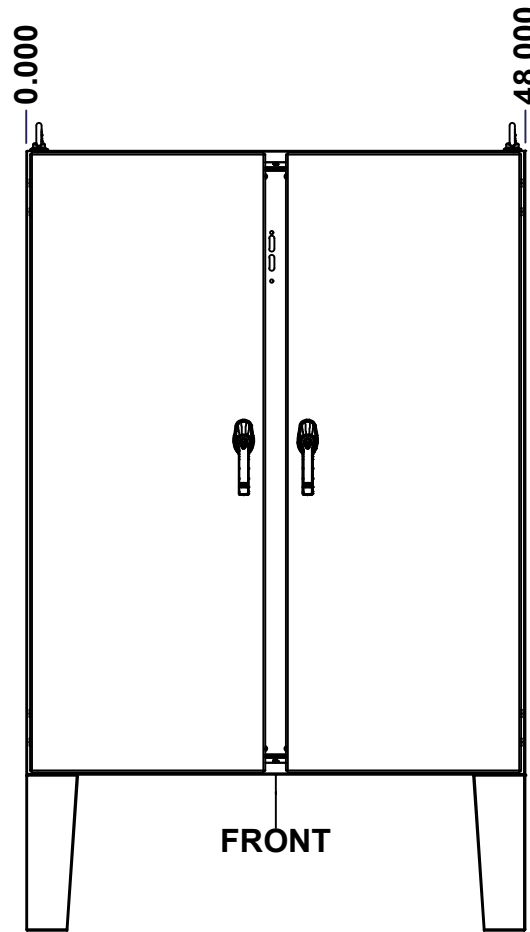

FRONT

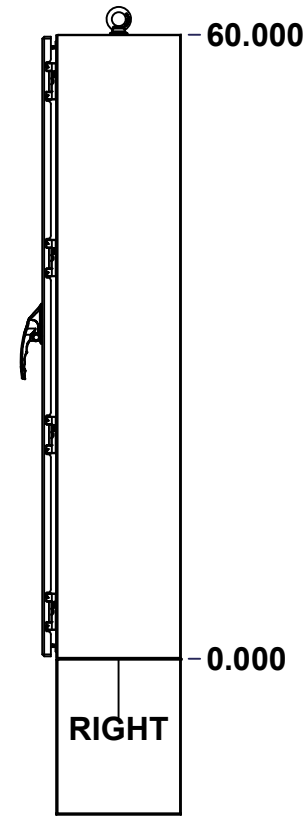

RIGHT

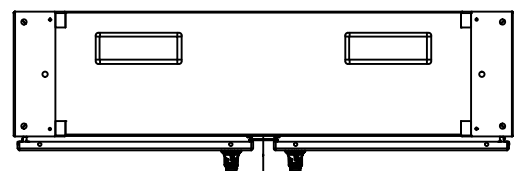

BOTTOM

No.	Revisions	Date	By/Par
1	update	07-Nov-24	Boxcad

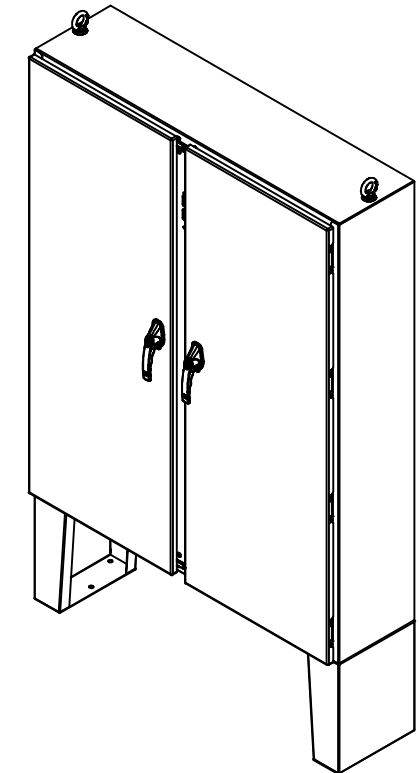

Isometric View

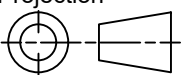

 Tél: (450) 979-4373 Fax: (450) 979-4626 www.exmweb.com		Flatness Aplatissement Max 3.0mm Projection 
Customer Client	Date	
Drawn By Dessiné Par	BoxCad: BoxCad	Date 03-Nov-14
Material Matière	12 Ga Cold Rolled A1008 CS Type B (2.5mm)	
Color Couleur	Asa-61 Grey	Finish Fini Smooth
Description 5500UCD 60" x 48" x 12" Assembly		Detail Rev.
Part Number Numéro Pièce	5500UCD604812	Rev. 1

SEE BILL OF MATERIAL ON LAST PAGE

This drawing is confidential and must not be reproduced or used without the consent of EXM

Ce dessin est confidentiel et ne doit pas être reproduit ou utilisé sans le consentement de EXM

NOTE	
ITEM	DESCRIPTION
1	NEMA 12, 13 Enclosure (IP55)
2	C/W Standard ground studs on box and cover
3	W/O Standard door stiffener
4	C/W Standard inner panel (Included)
5	C/W Standard inner panel mounting studs
6	C/W Eyebolts sold separately (Installed by EXM)
7	C/W Mounting feet sold separately (Installed)
8	C/W Struts installed (Included)

No.	Revisions	Date	By/Par
1	update	07-Nov-24	Boxcad

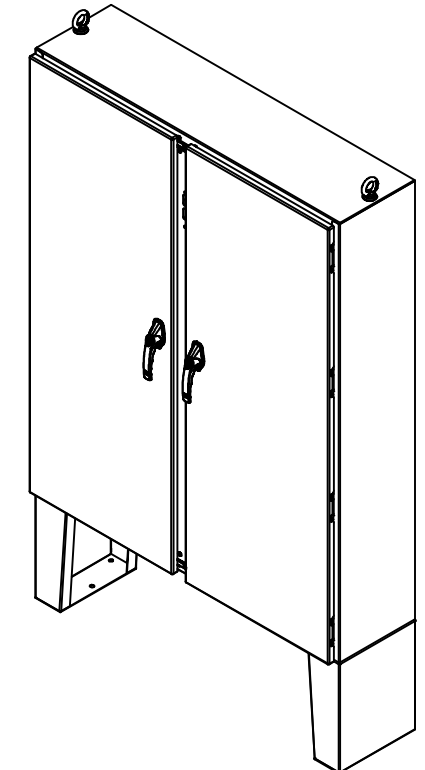

Isometric View

PACKING		
ITEM	QTY	DESCRIPTION
Cardboard sleeve	2	Top and Bottom
Cardboard strip	2	Between back of enclosure and inner panel
Plastic bag	1	To protect cover surface and inside gasket
Cardboard corner	4	To reinforced for the plastic strap tightening
Plastic strap - Black	2	To Squeeze 2 cardboard sleeve together
Packaging label	3	White label with PN
Plastic strap- Green	2	To secure the enclosure to the wood pallet
Wood Pallet	1	2" deeper and 3" larger than enclosure size

1	5500UCD604812MF	1	885 MFHD 15" x 12" Mounting Feet
1	880INTI	4	880 INTI - Interlock Post Kit
1	880EB14	2	Eye Bolt M14 (Pack of 2)
8	STK-Q-07320	0	Flange Lock Nut M10
1	885SP6048G	0	885 SP6048G Inner Panel
8	STK-Q-07620	0	M10 Plastic Spacer 0.875"
1	5500UCD604812FD	1	5500UCD 60" x 48" Lock Door
1	5500UCD604812LD	1	5500UCD 60" x 48" Flange Door
1	5500UCD604812B	1	5500UCD 60" x 48" x 12" Body
2	5500UCD604812GP	1	5500UCD Gland Plate
8	STK-Q-04050-10	8	M6 x 10mm Hexagon Socket Head Machine Screw with Nyseal
Qty	Part Number	Rev	Description
Parts List			

	Tél: (450) 979-4373 Fax: (450) 979-4626 www.exmweb.com	Flatness Aplatissement Max 3.0mm Projection
	Customer Client	Date
Drawn By Dessiné Par	BoxCad: BoxCad	Date 03-Nov-14
Material Matière	12 Ga Cold Rolled A1008 CS Type B (2.5mm)	
Color Couleur	Asa-61 Grey	Finish Fini Smooth
Description 5500UCD 60" x 48" x 12" Assembly	Detail Rev.	
Part Number Numéro Pièce 5500UCD604812	Rev. 1	2 18

This drawing is confidential and must not be reproduced or used without the consent of EXM

Ce dessin est confidentiel et ne doit pas être reproduit ou utilisé sans le consentement de EXM

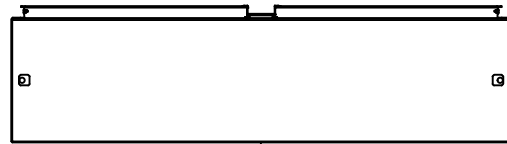

TOP

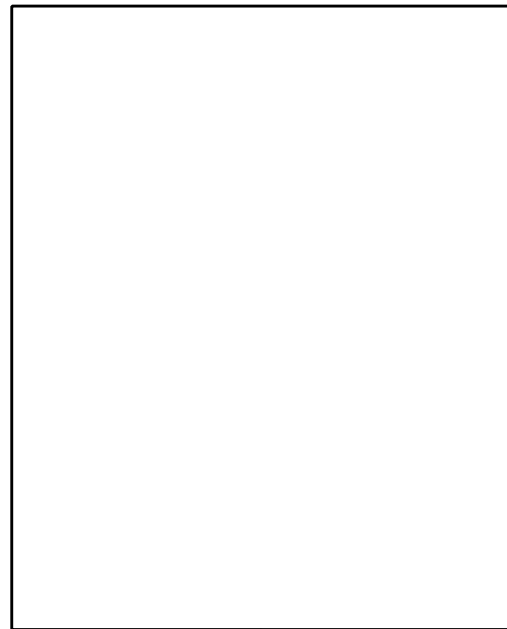

BACK

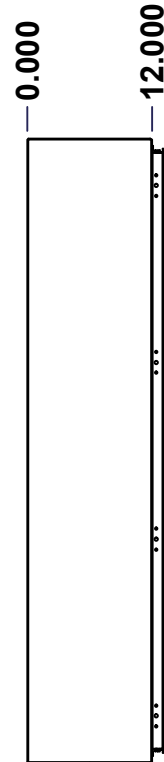

LEFT

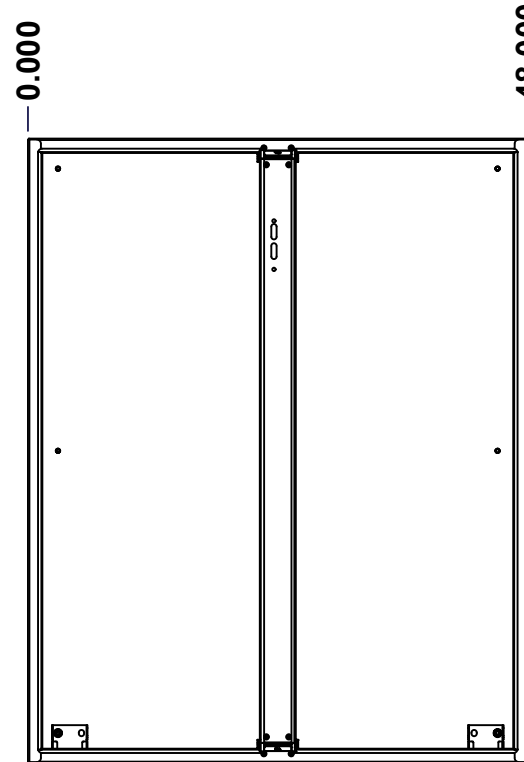

FRONT

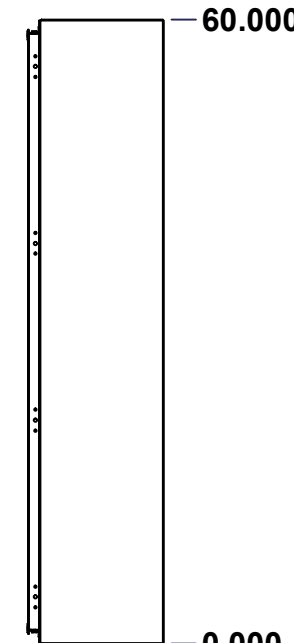

RIGHT

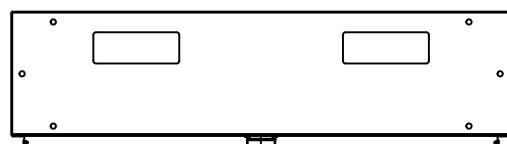

BOTTOM

No.	Revisions	Date	By/Par
1	update	07-Nov-24	Boxcad

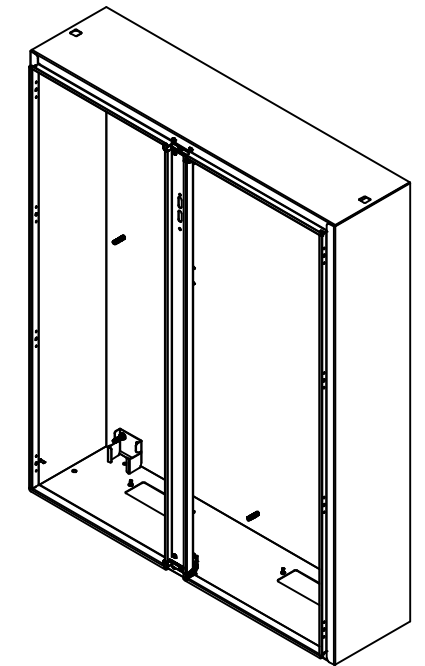

Isometric View



Tél: (450) 979-4373
 Fax: (450) 979-4626
www.exmweb.com

Flatness
Aplatissement

Max 3.0mm

Projection

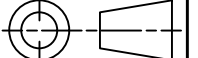

Customer Client	Date
Drawn By Dessiné Par BoxCad: BoxCad	Date 03-Nov-14

Material Matière 12 Ga Cold Rolled A1008 CS Type B (2.5mm)

Color Couleur Asa-61 Grey Finish Fini Smooth

Description 5500UCD 60" x 48" x 12" Body Detail Rev.

Part Number Numéro Pièce	Rev.	3
5500UCD604812B	1	18

SEE BILL OF MATERIAL ON LAST PAGE

This drawing is confidential and must not be reproduced or used without the consent of EXM

Ce dessin est confidentiel et ne doit pas être reproduit ou utilisé sans le consentement de EXM

STANDARD FEATURES ARE NOT LISTED IN THIS HOLE TABLE

HOLE TABLE - TOP VIEW (CUSTOM FEATURE ONLY)

CUT-OUT	XDIM	YDIM	DESCRIPTION
1	35.911	7.911	Struts CR400 17.500" (Inside)
2	11.911	7.911	Struts CR400 17.500" (Inside)
3	35.911	8.840	STUDS M6 x 10mm (Inside)
4	44.777	7.911	STUDS M6 x 10mm (Inside)
5	11.911	8.840	STUDS M6 x 10mm (Inside)
6	20.777	7.911	STUDS M6 x 10mm (Inside)

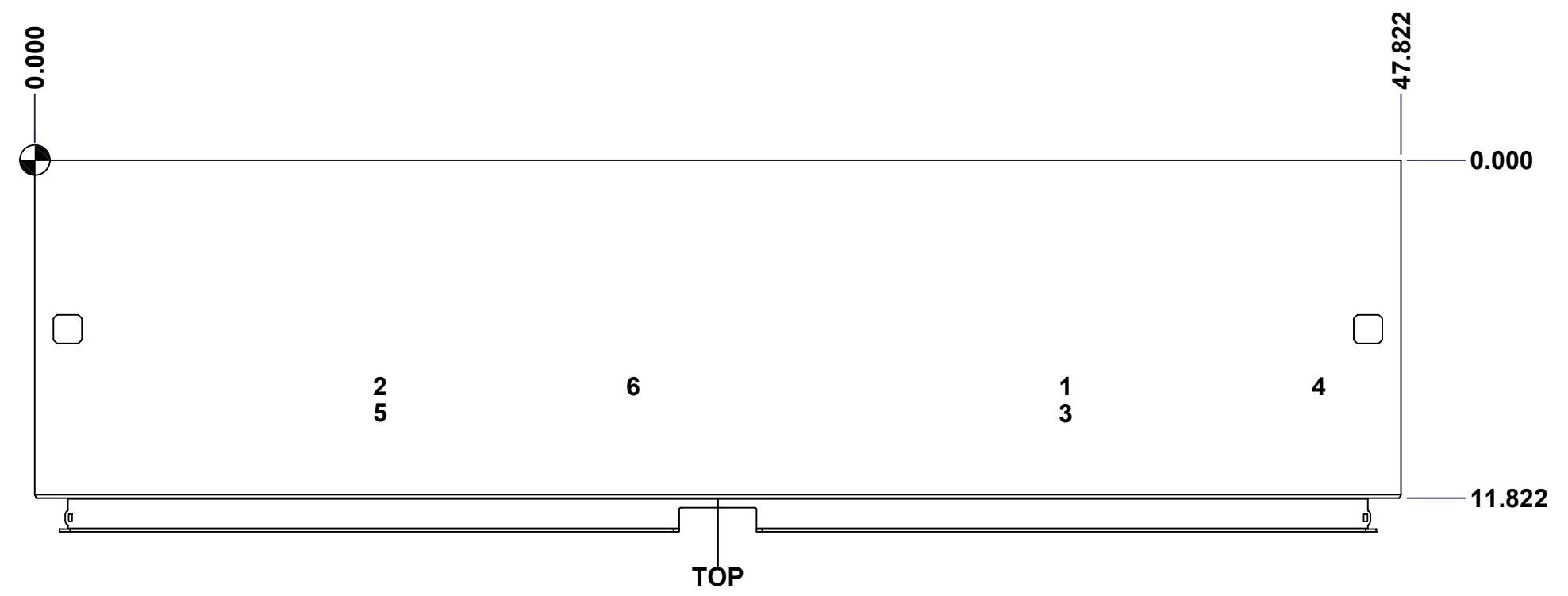

	Description	Status	
	5500UCD 60" x 48" x 12" Body	(NULL)	
	Part Number Numéro Pièce	Rev.	
	5500UCD604812B	1	4 18

This drawing is confidential and must not be reproduced or used without the consent of EXM

Ce dessin est confidentiel et ne doit pas être reproduit ou utilisé sans le consentement de EXM

STANDARD FEATURES ARE NOT LISTED IN THIS HOLE TABLE			
HOLE TABLE - RIGHT VIEW (CUSTOM FEATURE ONLY)			
CUT-OUT	XDIM	YDIM	DESCRIPTION
1	10.411	3.286	GND STUD M6 x 16mm (Inside)

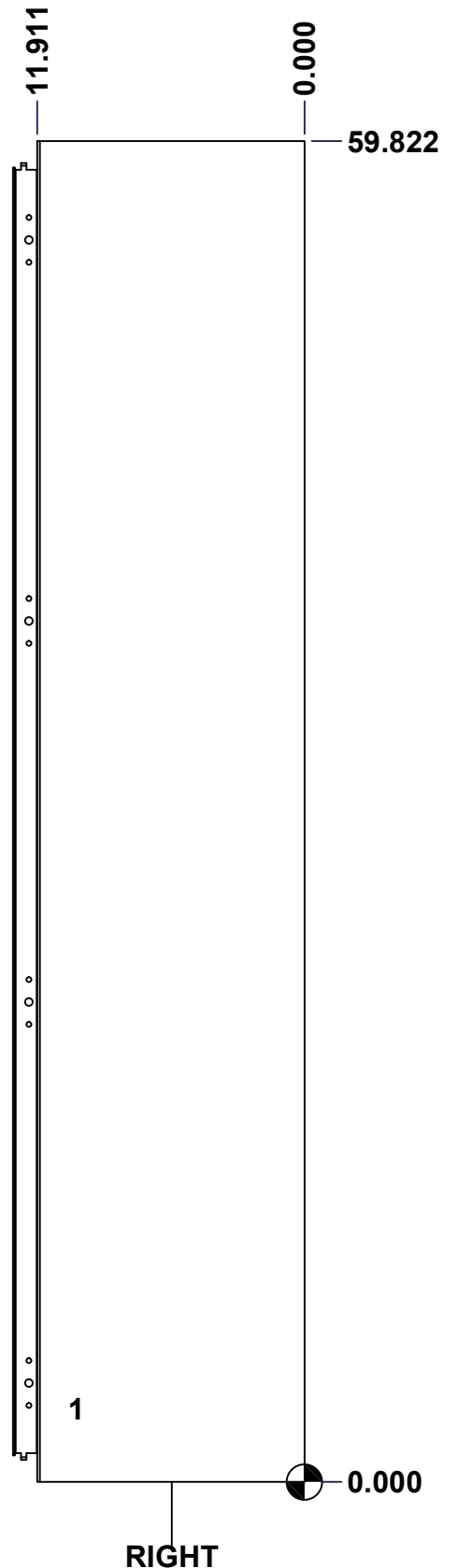

	Description	Status	
	5500UCD 60" x 48" x 12" Body	(NULL)	
	Part Number Numéro Pièce	Rev.	5
	5500UCD604812B	1	18

This drawing is confidential and must not be reproduced or used without the consent of EXM

Ce dessin est confidentiel et ne doit pas être reproduit ou utilisé sans le consentement de EXM

STANDARD FEATURES ARE NOT LISTED IN THIS HOLE TABLE			
HOLE TABLE - LEFT VIEW (CUSTOM FEATURE ONLY)			
CUT-OUT	XDIM	YDIM	DESCRIPTION
1	10.411	3.286	GND STUD M6 x 16mm (Inside)

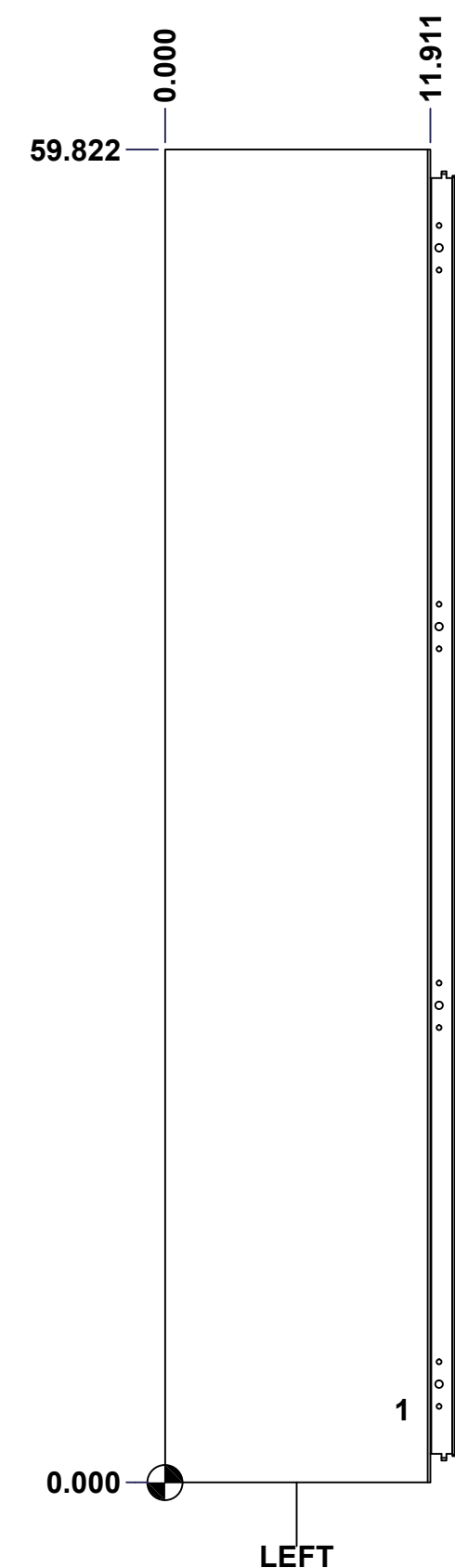

	Description	Status	
	5500UCD 60" x 48" x 12" Body	(NULL)	
	Part Number Numéro Pièce	Rev.	7
	5500UCD604812B	1	18

This drawing is confidential and must not be reproduced or used without the consent of EXM

Ce dessin est confidentiel et ne doit pas être reproduit ou utilisé sans le consentement de EXM

STANDARD FEATURES ARE NOT LISTED IN THIS HOLE TABLE

HOLE TABLE - BACK VIEW (CUSTOM FEATURE ONLY)

CUT-OUT	XDIM	YDIM	DESCRIPTION
1	2.786	2.786	IP STUD M10 x 40mm (Inside)
2	45.036	2.786	IP STUD M10 x 40mm (Inside)
3	2.786	29.911	IP STUD M10 x 40mm (Inside)
4	45.036	29.911	IP STUD M10 x 40mm (Inside)
5	2.786	57.036	IP STUD M10 x 40mm (Inside)
6	45.036	57.036	IP STUD M10 x 40mm (Inside)
7	23.911	2.786	IP STUD M10 x 40mm (Inside)
8	23.911	57.036	IP STUD M10 x 40mm (Inside)

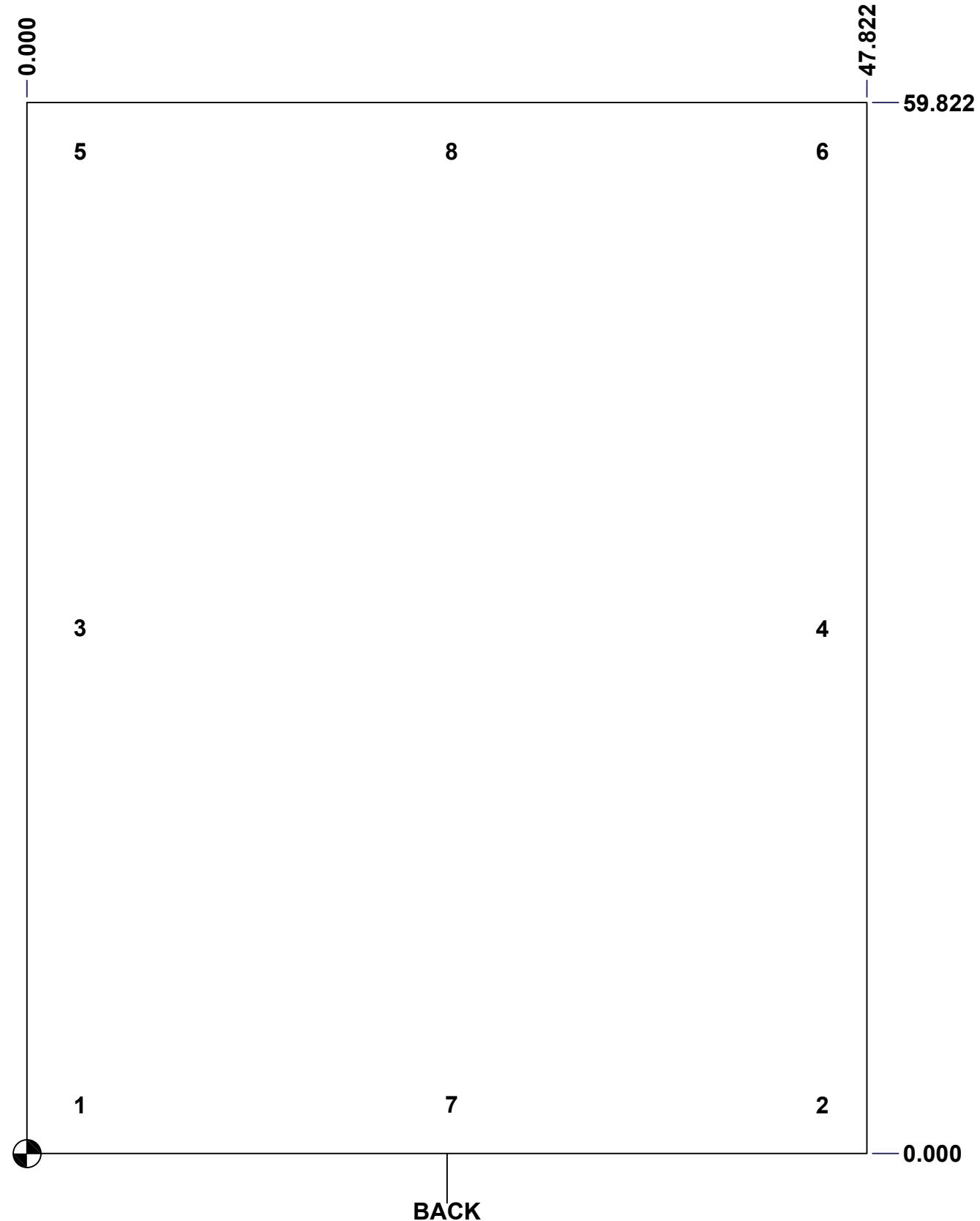

	Description	Status
	5500UCD 60" x 48" x 12" Body	(NULL)
	Part Number Numéro Pièce	Rev.
	5500UCD604812B	1
		8
		18

This drawing is confidential and must not be reproduced or used without the consent of EXM

Ce dessin est confidentiel et ne doit pas être reproduit ou utilisé sans le consentement de EXM

STANDARD FEATURES ARE NOT LISTED IN THIS HOLE TABLE			
HOLE TABLE - CENTER VIEW (CUSTOM FEATURE ONLY)			
CUT-OUT	XDIM	YDIM	DESCRIPTION
1	0.748	38.585	INTERLOCK STUD M6 x 16mm (Inside)
2	0.748	40.711	INTERLOCK STUD M6 x 16mm (Inside)
3	2.717	38.585	INTERLOCK STUD M6 x 16mm (Inside)
4	2.717	40.711	INTERLOCK STUD M6 x 16mm (Inside)

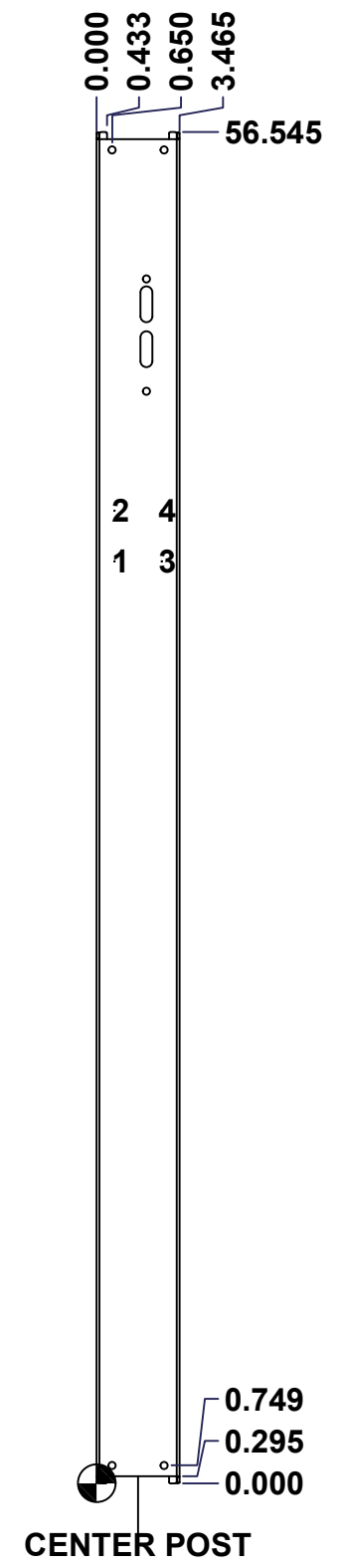

	Description	Status	
	5500UCD 60" x 48" x 12" Body	(NULL)	
	Part Number Numéro Pièce	Rev.	9
	5500UCD604812B	1	18

This drawing is confidential and must not be reproduced or used without the consent of EXM

Ce dessin est confidentiel et ne doit pas être reproduit ou utilisé sans le consentement de EXM

No.	Revisions	Date	By/Par
1	update	07-Nov-24	Boxcad

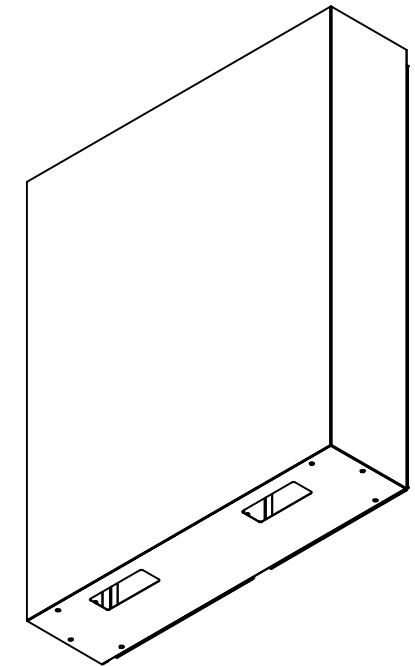

Isometric View



4	STK-Q-16030	0	Stud M6 x 10mm Steel
2	STK-Q-74900	0	Eyebolt Lifting Angle (8.750")
1	STK-P-02400S	0	Powder Paint (Asa-61 Grey / Smooth)
4	STK-Q-16055	1	M6 x 18mm Stud (No Paint Cap Required)
1	STK-A-75454	3	Center Post - Sealing Block with Latch Assembly (Large)
1	5500UCD604812CP-P	1	5500UCD 60" Center Post Part
2	STK-Q-07320	0	Flange Lock Nut M10
2	STK-Q-07618	1	5500 Series Inner Panel Support Bracket
8	STK-Q-16100	0	Stud M10 x 40mm Steel
1	5500UCD604812BT-P	1	5500UCD 48" x 12" Bottom Part
1	5500UCD604812T-P	1	5500UCD 48" x 12" Top Part
1	5500UCD604812RS-P	1	5500UCD 60" x 48" Right Part
1	5500UCD604812LS-P	1	5500UCD 60" x 48" Left Part
1	5500UCD604812B-P	1	5500UCD 60" x 48" Back Part
2	5500UCD604812_CR400 MS_17.5	0	Commercial Roll Mild Steel (17.5in long)
6	STK-Q-16080	0	Ground Stud M6 x 16mm Steel

Qty	Part Number	Rev	Description
Parts List			

Tél: (450) 979-4373 Fax: (450) 979-4626 www.exmweb.com	Flatness Aplatissement
	Max 3.0mm
Projection	
Customer Client	Date
Drawn By Dessiné Par BoxCad: BoxCad	Date 03-Nov-14
Material Matière 12 Ga Cold Rolled A1008 CS Type B (2.5mm)	
Color Couleur Asa-61 Grey	Finish Fini Smooth
Description 5500UCD 60" x 48" x 12" Body	Detail Rev.
Part Number Numéro Pièce 5500UCD604812B	Rev. 10 1 18

This drawing is confidential and must not be reproduced or used without the consent of EXM

Ce dessin est confidentiel et ne doit pas être reproduit ou utilisé sans le consentement de EXM

No.	Revisions	Date	By/Par
1	update	07-Nov-24	Boxcad

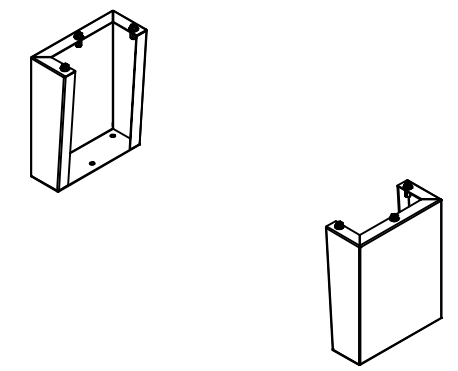
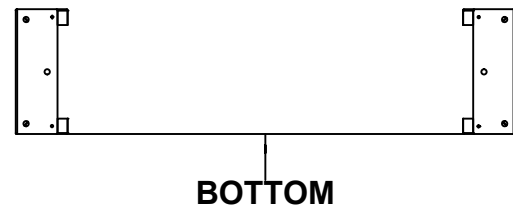
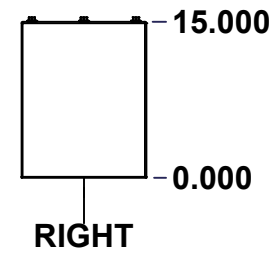
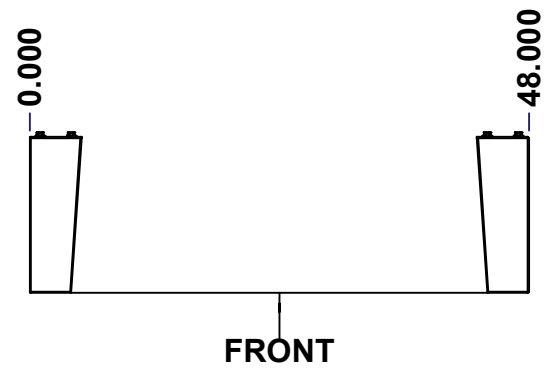
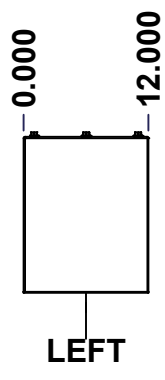
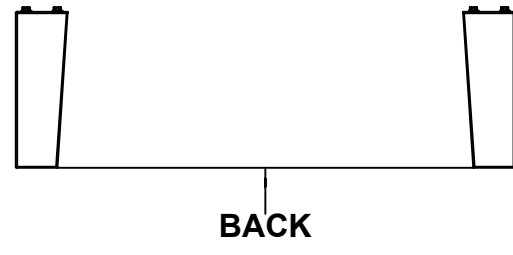
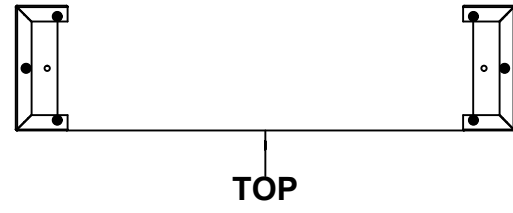

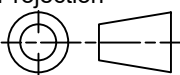
 Tél: (450) 979-4373 Fax: (450) 979-4626 www.exmweb.com		Flatness Aplatissement
		Max 3.0mm
Projection 		
Customer Client		Date
Drawn By Dessiné Par	BoxCad: BoxCad	Date 03-Nov-14
Material Matière	12 Ga Cold Rolled A1008 CS Type B (2.5mm)	
Color Couleur	Asa-61 Grey	Finish Fini Smooth
Description		Detail Rev.
885 MFHD 15" x 12" Mounting Feet		
Part Number Numéro Pièce	Rev. 1	11
5500UCD604812MF		18

SEE BILL OF MATERIAL ON LAST PAGE

This drawing is confidential and must not be reproduced or used without the consent of EXM

Ce dessin est confidentiel et ne doit pas être reproduit ou utilisé sans le consentement de EXM

No.	Revisions	Date	By/Par
1	update	07-Nov-24	Boxcad

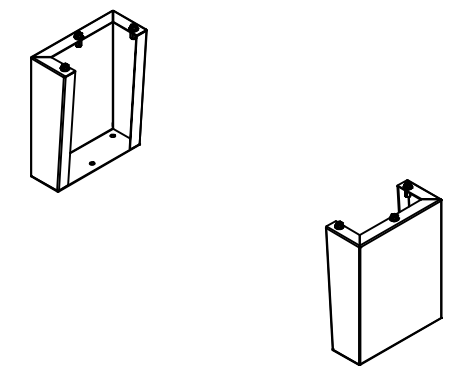

Isometric View

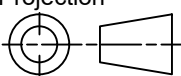

 Tél: (450) 979-4373 Fax: (450) 979-4626 www.exmweb.com		Flatness Aplatissement Max 3.0mm Projection 
Customer Client	Date	
Drawn By Dessiné Par	BoxCad: BoxCad	Date 03-Nov-14
Material Matière	12 Ga Cold Rolled A1008 CS Type B (2.5mm)	
Color Couleur	Asa-61 Grey	Finish Fini Smooth
Description		Detail Rev.
885 MFHD 15" x 12" Mounting Feet		
Part Number Numéro Pièce	Rev.	12
5500UCD604812MF	1	18

Qty	Part Name	Rev	Description
1	STK-P-02400S	0	Powder Paint (Asa-61 Grey / Smooth)
6	RIVET_NUT_M10_FH_CE	0	Rivet Nut M10 (Low Profile Close End)
1	5500UCD604812MFR-P	1	885 MFHD 15" x 12" Right Mounting Feet Part
1	5500UCD604812MFL-P	1	885 MFHD 15" x 12" Left Mounting Feet Part
3	STK-K-11600	2	885 MF Accessory Kit
Parts List			

This drawing is confidential and must not be reproduced or used without the consent of EXM

Ce dessin est confidentiel et ne doit pas être reproduit ou utilisé sans le consentement de EXM

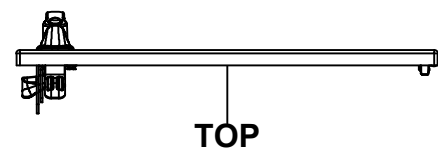

TOP

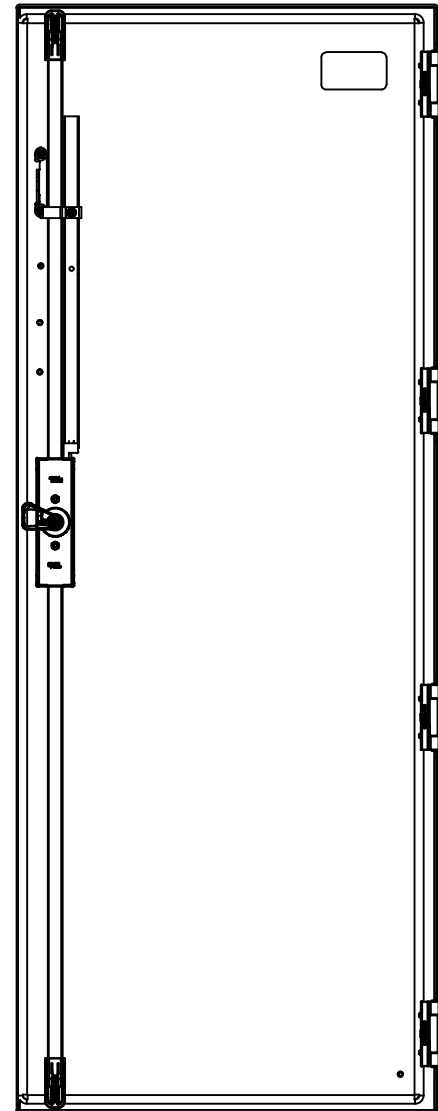

BACK



BOTTOM

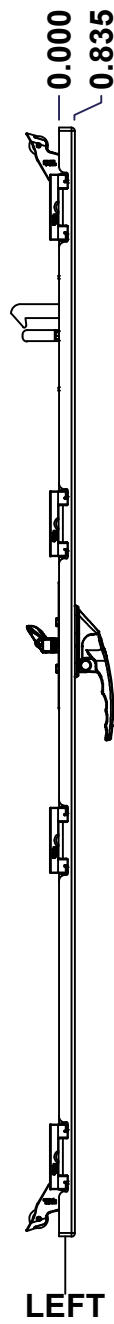

LEFT

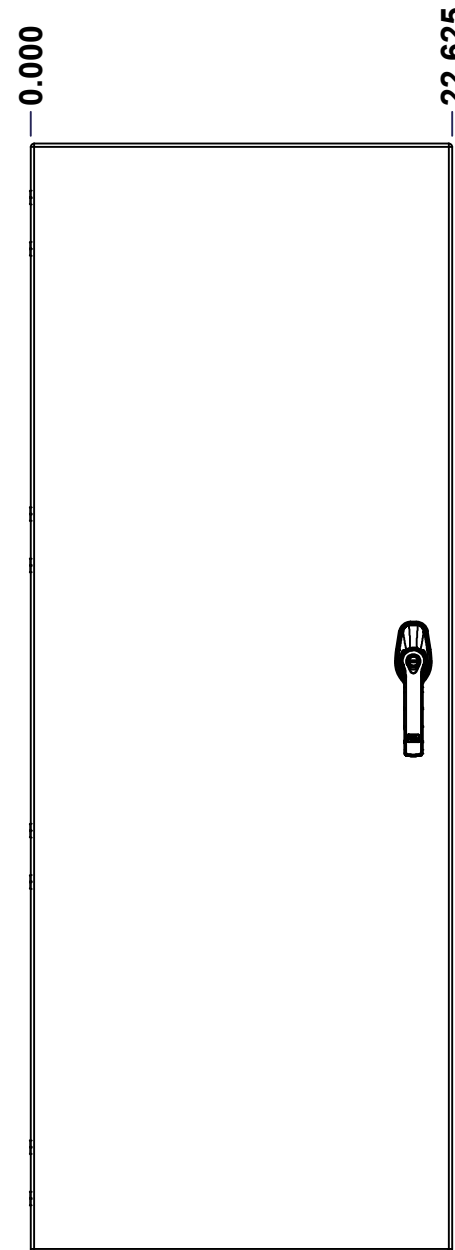

FRONT

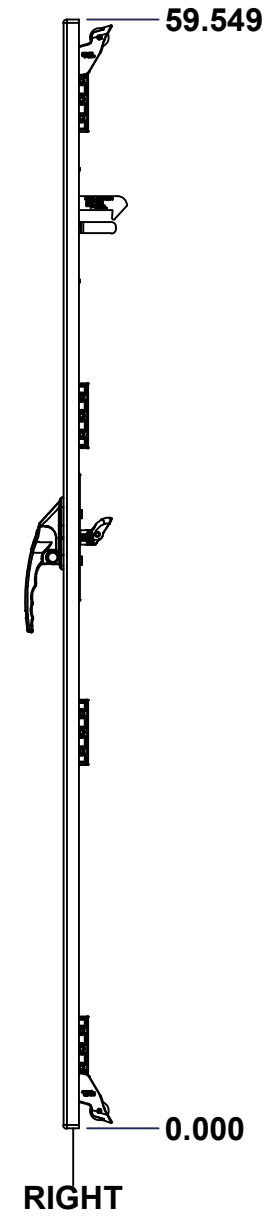

RIGHT

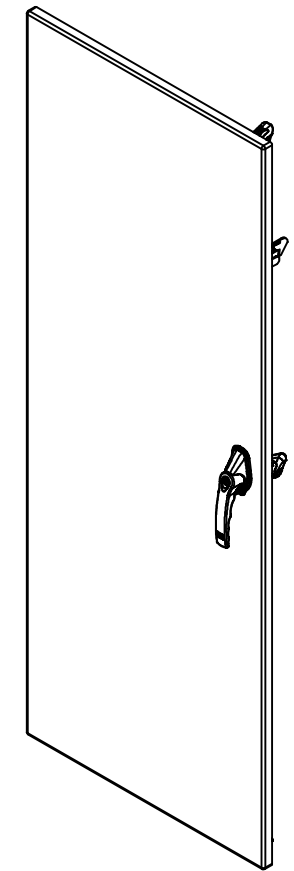

Isometric View

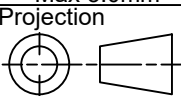

No.	Revisions	Date	By/Par
1	update	07-Nov-24	Boxcad

 Tél: (450) 979-4373 Fax: (450) 979-4626 www.exmweb.com		Flatness Aplatissement Max 3.0mm Projection 
Customer Client	Date	
Drawn By Dessiné Par	BoxCad: BoxCad	Date 03-Nov-14
Material Matière	12 Ga Cold Rolled A1008 CS Type B (2.5mm)	
Color Couleur	Asa-61 Grey	Finish Fini Smooth
Description	Detail Rev.	
5500UCD 60" x 48" Flange Door		
Part Number Numéro Pièce	Rev.	13
5500UCD604812LD	1	18

SEE BILL OF MATERIAL ON LAST PAGE

This drawing is confidential and must not be reproduced or used without the consent of EXM

Ce dessin est confidentiel et ne doit pas être reproduit ou utilisé sans le consentement de EXM

STANDARD FEATURES ARE NOT LISTED IN THIS HOLE TABLE

HOLE TABLE - FRONT VIEW (CUSTOM FEATURE ONLY)

CUT-OUT	XDIM	YDIM	DESCRIPTION
1	21.311	51.511	STUD M6 x 18mm (Inside)
2	21.311	48.511	STUD M6 x 18mm (Inside)
3	21.311	45.511	STUD M6 x 18mm (Inside)
4	20.534	6.179	LARGE CBAR GUIDE (Inside)
5	20.534	53.370	LARGE CBAR GUIDE (Inside)
6	19.678	51.870	LARGE CBAR GUIDE (Inside)
-----	-----	-----	-----
7	2.000	2.118	GND STUD M6 x 16mm (Inside)
8	20.544	31.743	HANDLE 885 ESL2A-APHD @ 0.0°
9	21.372	42.488	STUDS M6 x 18mm (Inside)
10	21.372	39.810	STUDS M6 x 18mm (Inside)

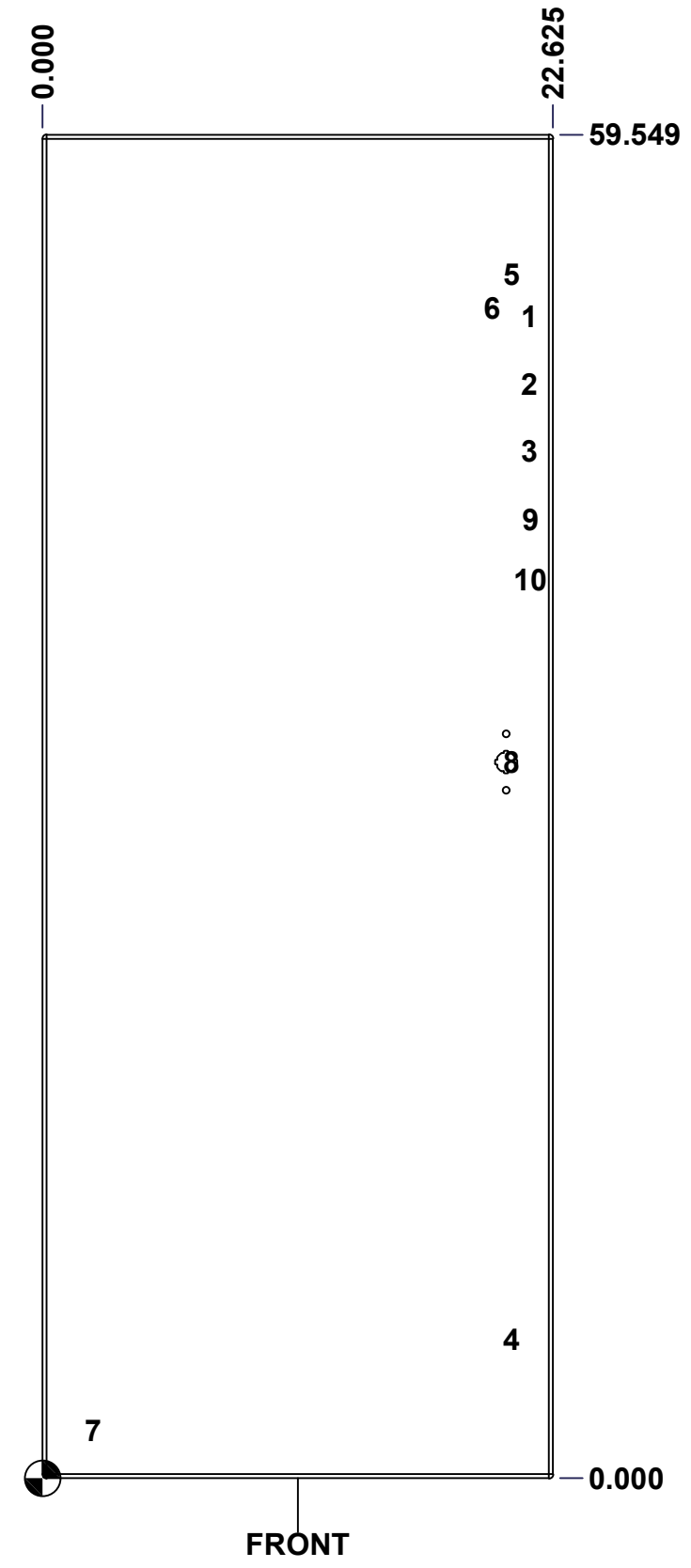

	Description	Status
	5500UCD 60" x 48" Flange Door	(NULL)
Part Number Numéro Pièce 5500UCD604812LD	Rev.	14
	1	18

This drawing is confidential and must not be reproduced or used without the consent of EXM

Ce dessin est confidentiel et ne doit pas être reproduit ou utilisé sans le consentement de EXM

No.	Revisions	Date	By/Par
1	update	07-Nov-24	Boxcad

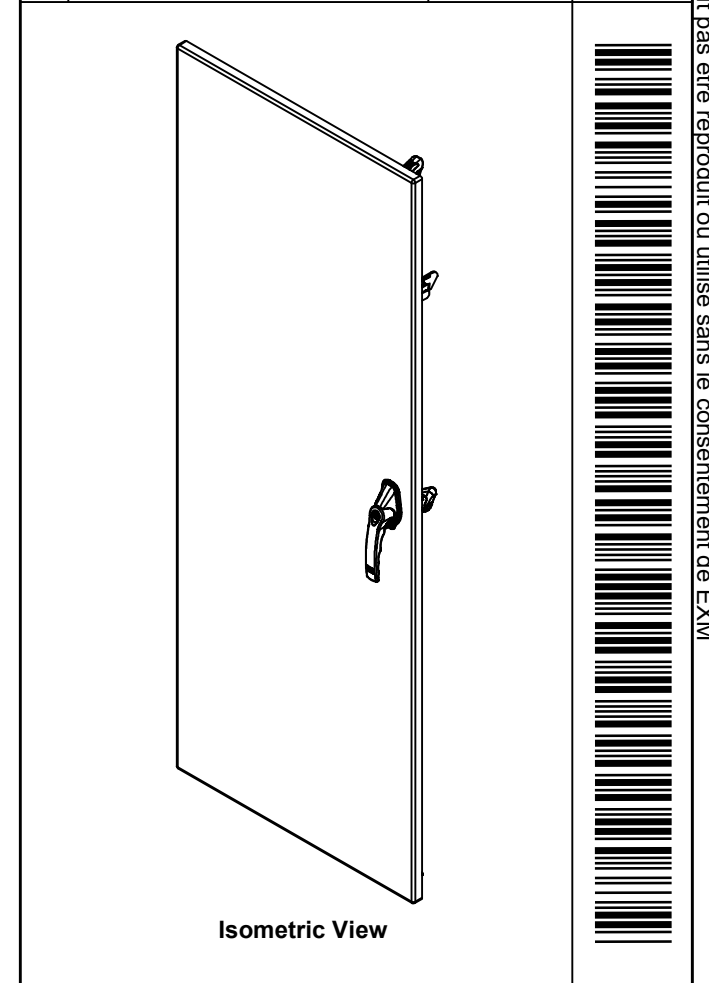

EXM
www.exmweb.com

Tél: (450) 979-4373
Fax: (450) 979-4626

Flatness
Aplatissement
Max 3.0mm

Projection

1	STK-K-55060	0	5500 UCD and UFD 60" Locking Mechanism Kit
2	STK-Q-16050	1	Stud M6 x 18mm Steel
1	885ESL2A-APHD	1	885 ESL2A-APHD - Zinc Die Cast L-Handle Padlockable Assy - Slot Cylinder
1	STK-Q-16080	0	Ground Stud M6 x 16mm Steel
1	STK-P-02400S	0	Powder Paint (Asa-61 Grey / Smooth)
1	STK-S-00100	0	3.5" x 2" Silver Milar Flexcon Sticker
3	STK-Q-16055	1	M6 x 18mm Stud (No Paint Cap Required)
3	STK-Q-16410	0	Guide Stud - Largel (No Paint Cap Required)
1	5500UCD604812LDG	1	5500UCD 60" x 48" Lock Door Gasket
1	5500UCD604812LD-P	1	5500UCD 60" x 48" Lock Door Part
4	STK-K-09860	7	Cabinet Hinge with Captive Pins
QTY	Part Number	Rev	Description
Parts List			

Customer Client	Date
Drawn By Dessiné Par	Date 03-Nov-14
Material Matière	BoxCad: BoxCad
Color Couleur	12 Ga Cold Rolled A1008 CS Type B (2.5mm)
Asa-61 Grey	Finish Fini
Smooth	Description
5500UCD 60" x 48" Flange Door	Detail Rev.
Part Number Numéro Pièce	Rev. 15
5500UCD604812LD	1 18

This drawing is confidential and must not be reproduced or used without the consent of EXM

Ce dessin est confidentiel et ne doit pas être reproduit ou utilisé sans le consentement de EXM

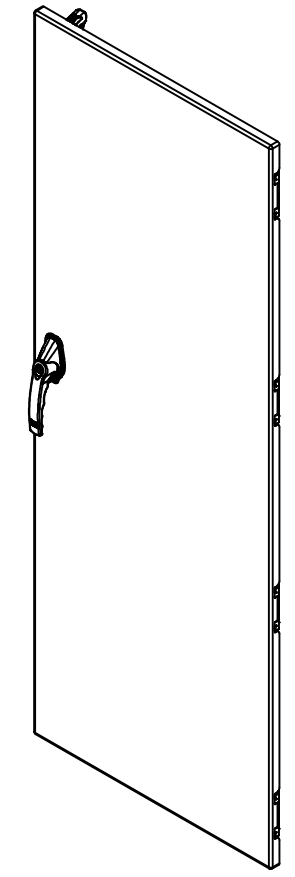
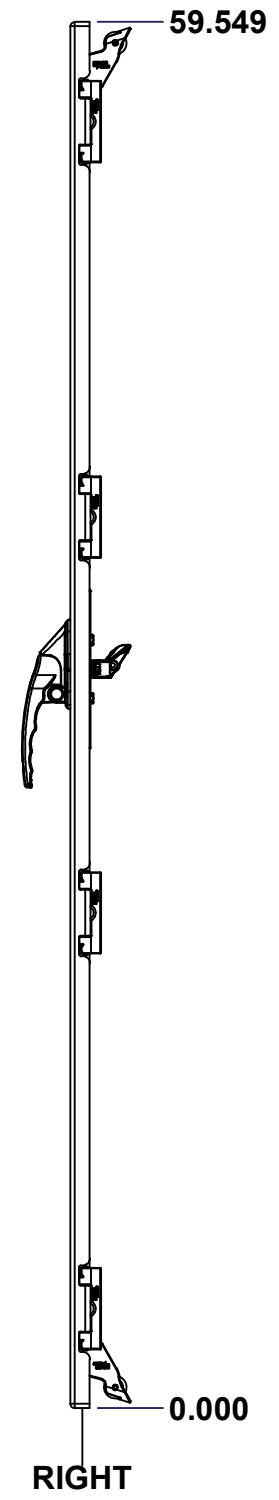
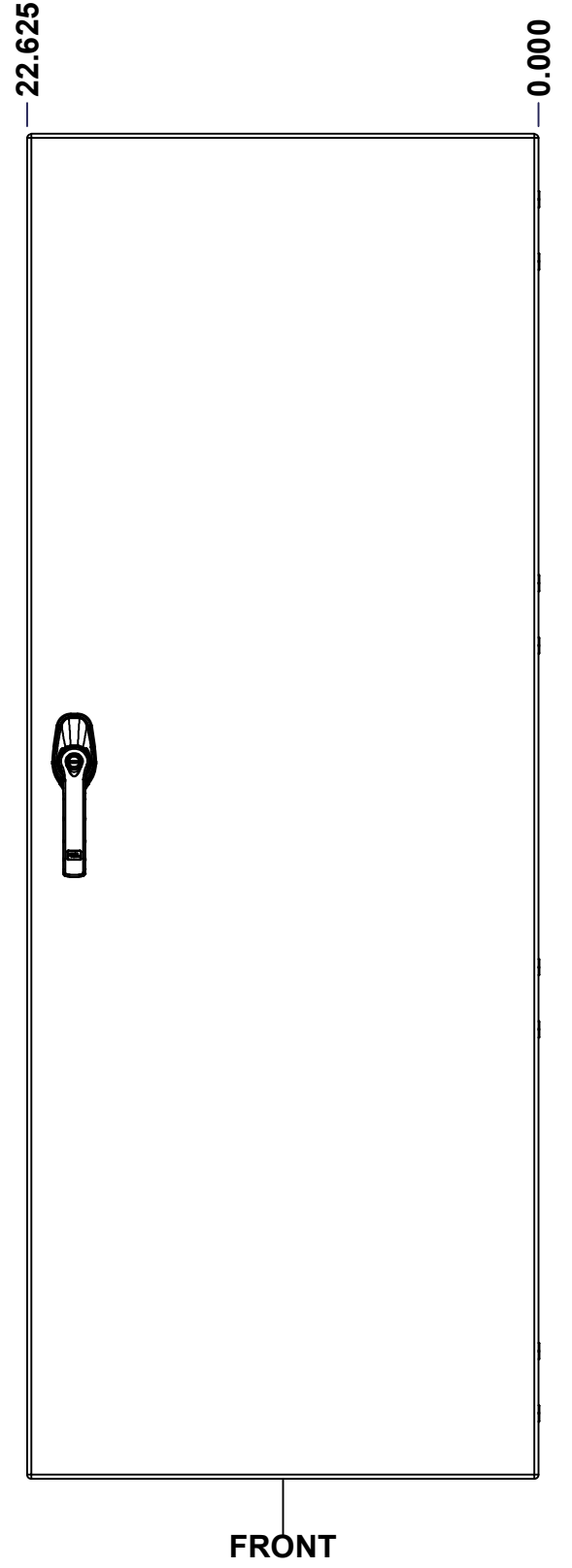
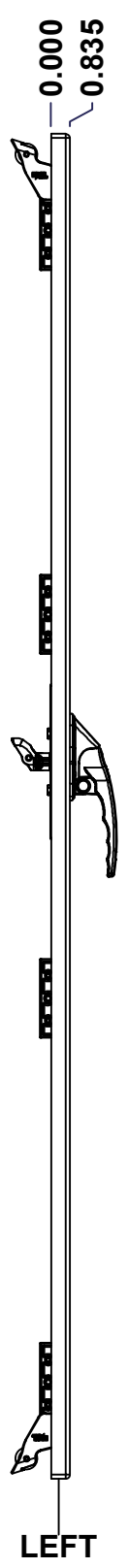
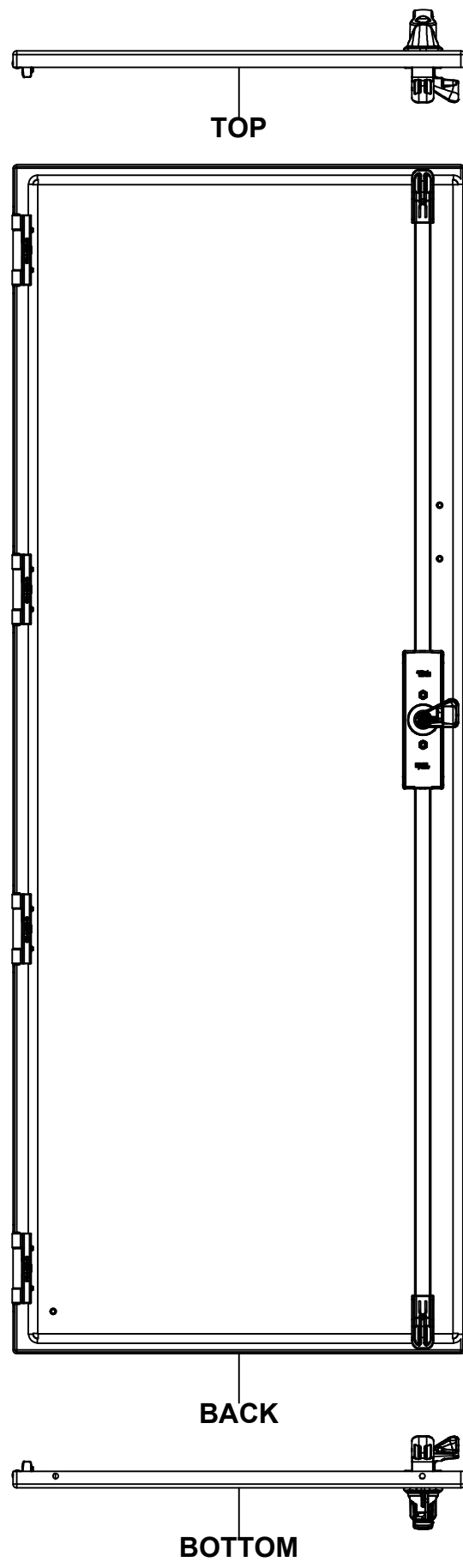

Isometric View

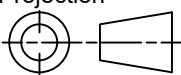

No.	Revisions	Date	By/Par
1	update	07-Nov-24	Boxcad

 Tél: (450) 979-4373 Fax: (450) 979-4626 www.exmweb.com		Flatness Aplatissement Max 3.0mm Projection 
Customer Client	Date	
Drawn By Dessiné Par	BoxCad: BoxCad	Date 03-Nov-14
Material Matière	12 Ga Cold Rolled A1008 CS Type B (2.5mm)	
Color Couleur	Asa-61 Grey	Finish Fini Smooth
Description		Detail Rev.
5500UCD 60" x 48" Lock Door		
Part Number Numéro Pièce	Rev. 1	16 18

SEE BILL OF MATERIAL ON LAST PAGE

5500UCD604812FD

This drawing is confidential and must not be reproduced or used without the consent of EXM

Ce dessin est confidentiel et ne doit pas être reproduit ou utilisé sans le consentement de EXM

STANDARD FEATURES ARE NOT LISTED IN THIS HOLE TABLE

HOLE TABLE - FRONT VIEW (CUSTOM FEATURE ONLY)

CUT-OUT	XDIM	YDIM	DESCRIPTION
1	20.544	6.118	LARGE GUIDE STUD (Inside)
2	20.544	53.431	LARGE GUIDE STUD (Inside)
-----	-----	-----	-----
3	2.000	2.118	GND STUD M6 x 16mm (Inside)
4	20.544	31.743	HANDLE 885 ESL2A-APHD
5	21.372	42.488	STUDS M6 x 18mm (Inside)
6	21.372	39.810	STUDS M6 x 18mm (Inside)

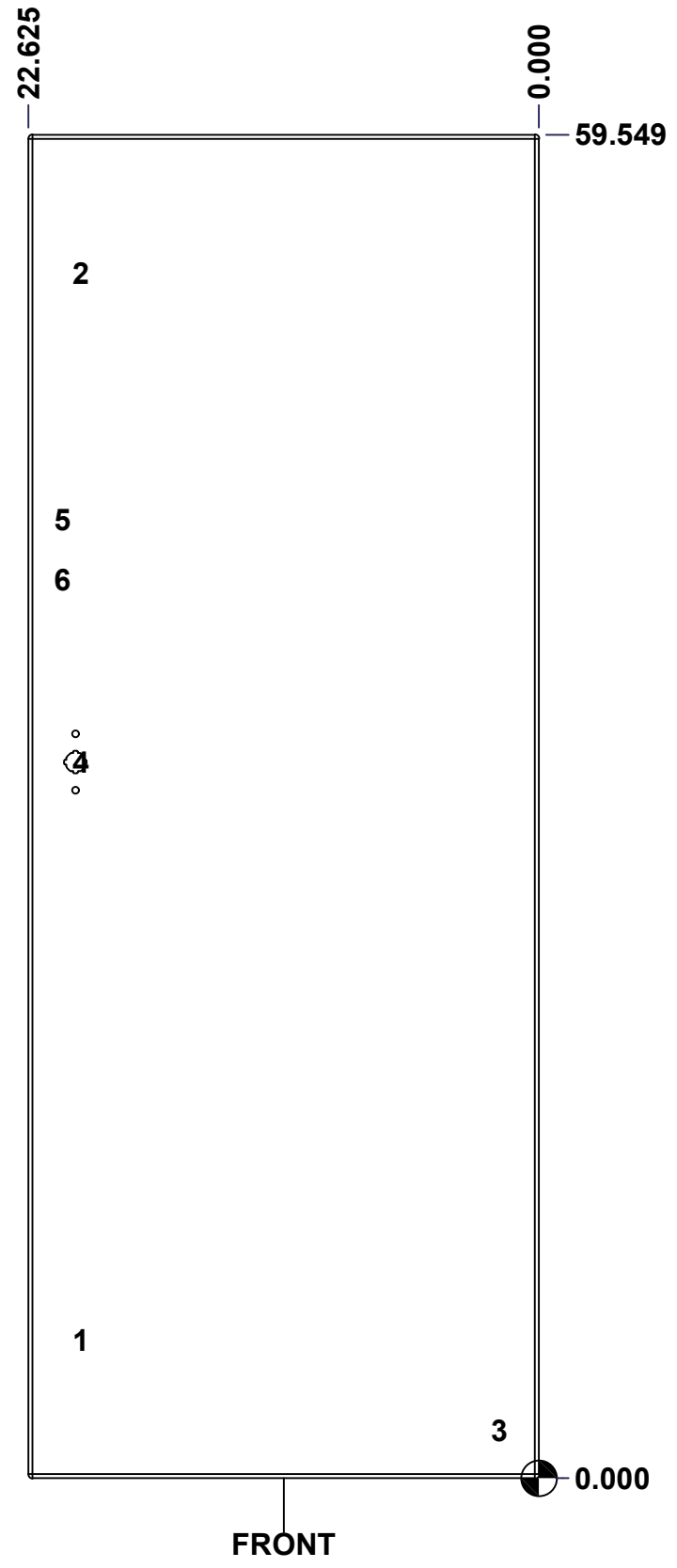

	Description	Status
	5500UCD 60" x 48" Lock Door	(NULL)
	Part Number Numéro Pièce	Rev.
	5500UCD604812FD	1
		17
		18

This drawing is confidential and must not be reproduced or used without the consent of EXM

Ce dessin est confidentiel et ne doit pas être reproduit ou utilisé sans le consentement de EXM

No.	Revisions	Date	By/Par
1	update	07-Nov-24	Boxcad

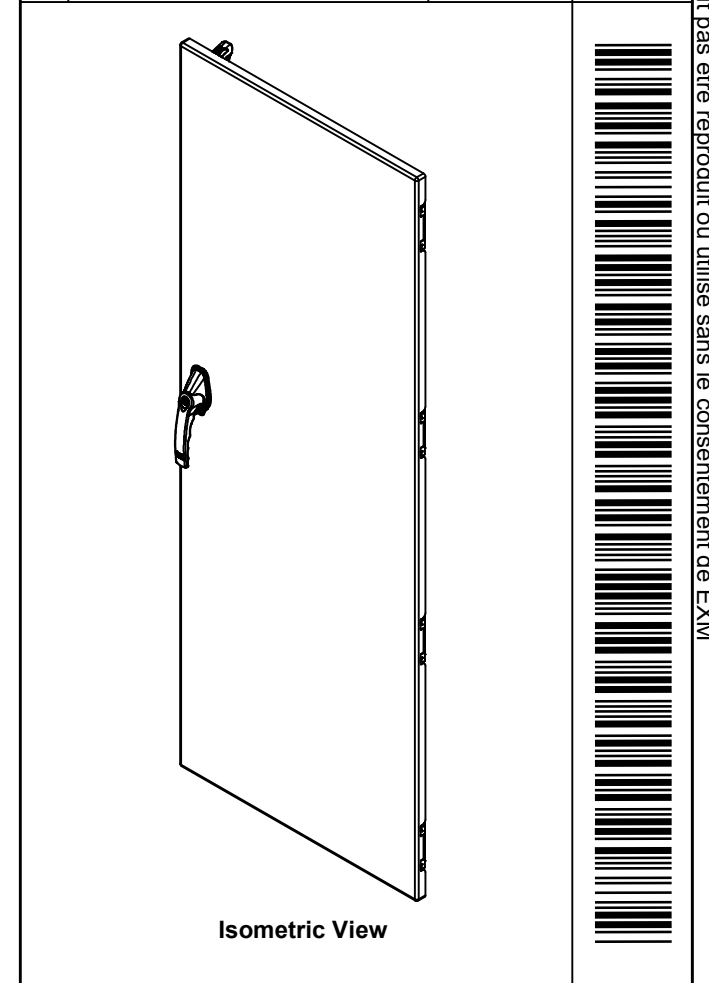

2	STK-Q-16050	1	Stud M6 x 18mm Steel
1	STK-Q-47521	2	5500 DDS Lower Closing Bar 60"
1	STK-Q-47511	2	5500 DDS Upper Closing Bar 60"
1	STK-A-03986-36	2	Gearbox Counterclockwise Assembly (36.0mm)
1	885ESL2A-APHD	1	885 ESL2A-APHD - Zinc Die Cast L-Handle Padlockable Assy - Slot Cylinder
1	STK-Q-16080	0	Ground Stud M6 x 16mm Steel
1	STK-P-02400S	0	Powder Paint (Asa-61 Grey / Smooth)
2	STK-Q-16410	0	Guide Stud - Largel (No Paint Cap Required)
1	5500UCD604812FDG	1	5500UCD 60" x 48" Flange Door Gasket
1	5500UCD604812FD-P	1	5500UCD 60" x 48" Lock Door Part
2	STK-A-90025	0	9500 - Cabinet Closing Bar End (Large)
4	STK-K-09860	7	Cabinet Hinge with Captive Pins
QTY	Part Number	Rev	Description
Parts List			

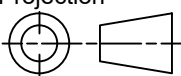
 Tél: (450) 979-4373 Fax: (450) 979-4626 www.exmweb.com		Flatness Aplatissement Max 3.0mm Projection 
Customer Client	Date	
Drawn By Dessiné Par	BoxCad: BoxCad	Date 03-Nov-14
Material Matière	12 Ga Cold Rolled A1008 CS Type B (2.5mm)	
Color Couleur	Asa-61 Grey	Finish Fini Smooth
Description	Detail Rev.	
5500UCD 60" x 48" Lock Door		
Part Number Numéro Pièce	Rev.	18
5500UCD604812FD	1	18

This drawing is confidential and must not be reproduced or used without the consent of EXM

Ce dessin est confidentiel et ne doit pas être reproduit ou utilisé sans le consentement de EXM



TOP

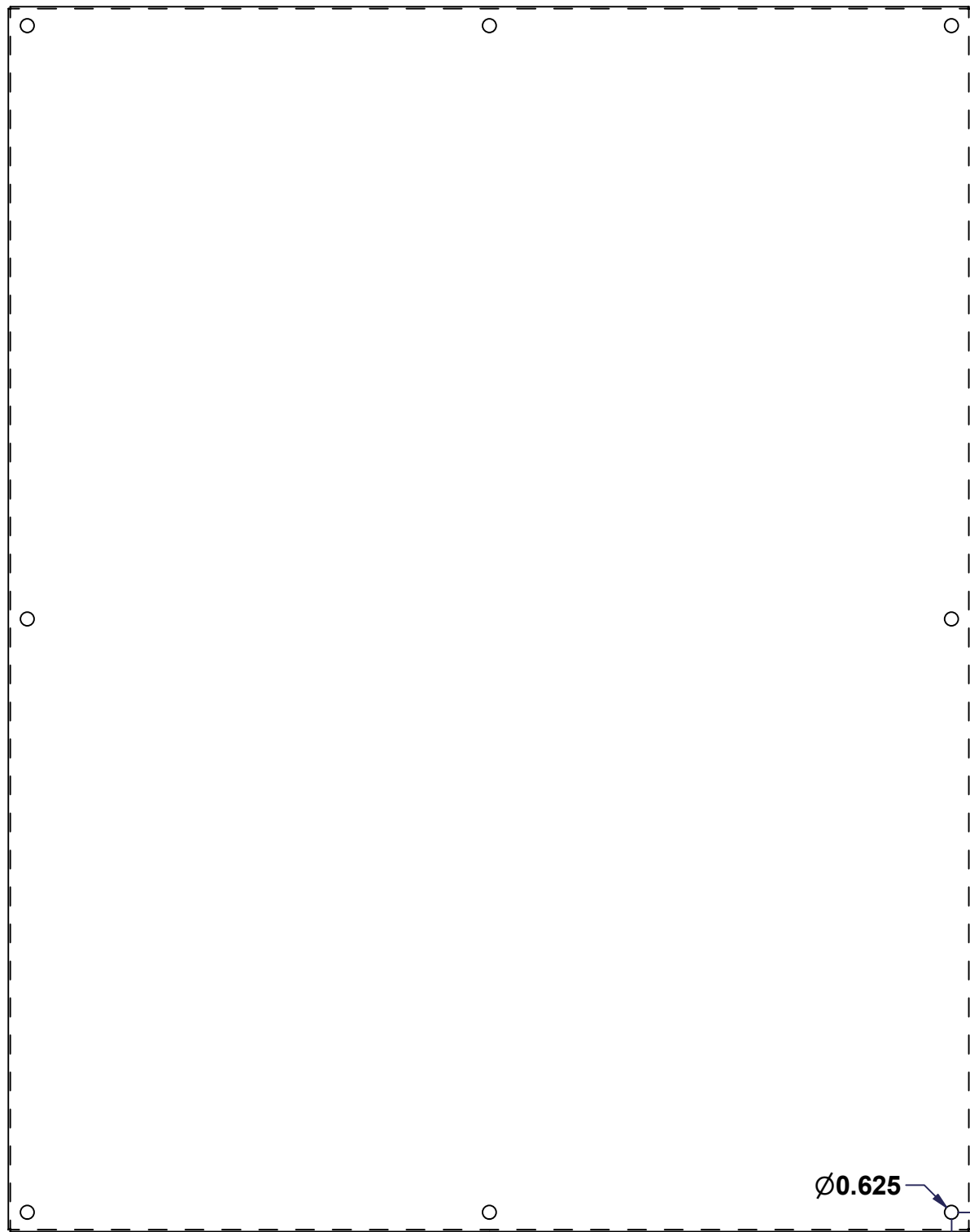

FRONT



RIGHT

0.000

SEE BILL OF MATERIAL ON LAST PAGE

No.	Revisions	Date	By/Par

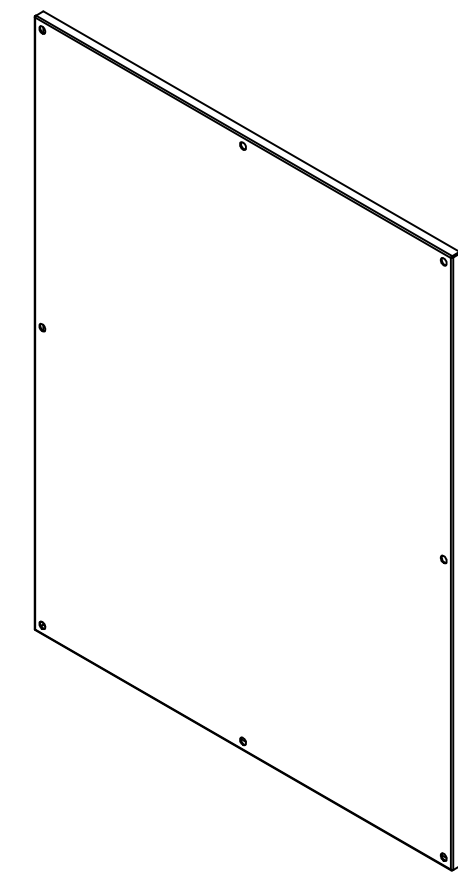

Isometric View



Tél: (450) 979-4373
 Fax: (450) 979-4626
 www.exmweb.com

Flatness
 Aplatissement
 Max 3.0mm
 Projection

Customer Client	Date
Drawn By Dessiné Par BoxCad	Date 04/11/2009
Material Matière 12 Ga Cold Rolled A1008 CS Type B (2.5mm)	

Color Couleur White RAL9003	Finish Fini Smooth
--------------------------------	-----------------------

Description 885 SP6048 Inner Panel	Detail Rev.
---------------------------------------	-------------

Part Number Numéro Pièce 885SP6048	Rev. 0	1 2
---------------------------------------	--------	--------

This drawing is confidential and must not be reproduced or used without the consent of EXM

Ce dessin est confidentiel et ne doit pas être reproduit ou utilisé sans le consentement de EXM

No.	Revisions	Date	By/Par

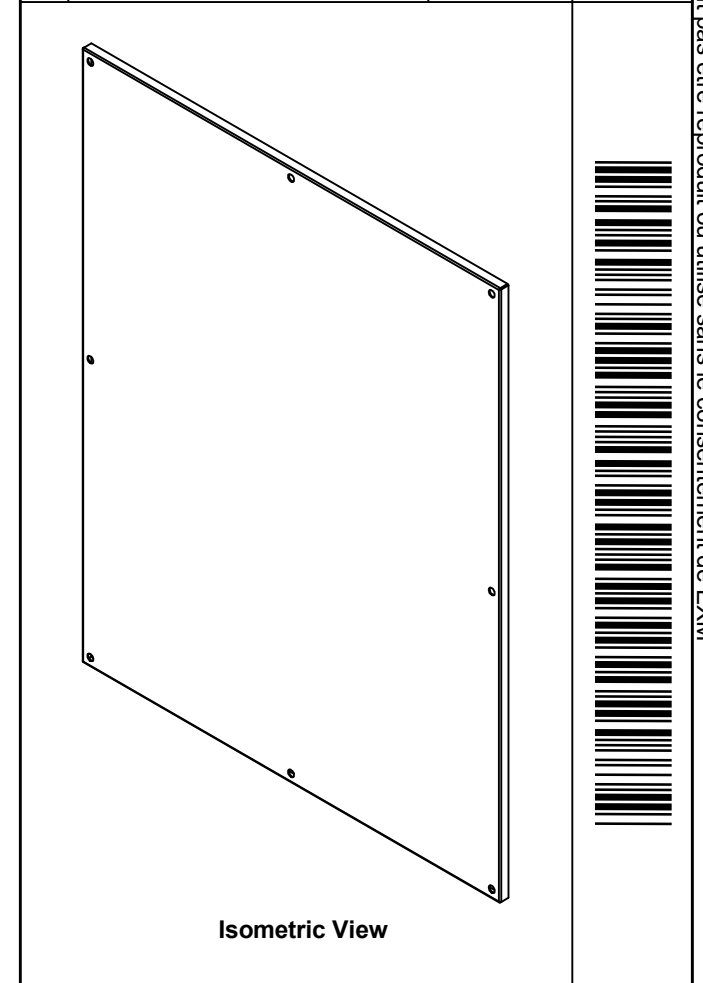

Tél: (450) 979-4373 Fax: (450) 979-4626 www.exmweb.com		Flatness Aplatissement	
		Max 3.0mm 	
Customer Client		Date	
Drawn By Dessiné Par BoxCad		Date 04/11/2009	
Material Matière 12 Ga Cold Rolled A1008 CS Type B (2.5mm)			
Color Couleur White RAL9003		Finish Fini Smooth	
Description 885 SP6048 Inner Panel			Detail Rev.
Part Number Numéro Pièce 885SP6048		Rev. 0	2 2

Qty	Part Number	Rev	Description
1	STK-P-02401S	0	Powder Paint (White / Smooth)
1	885SP6048-P	0	885 SP6048 Inner Panel Part
Parts List			