

This drawing is confidential and must not be reproduced or used without the consent of EXM

Ce dessin est confidentiel et ne doit pas être reproduit ou utilisé sans le consentement de EXM

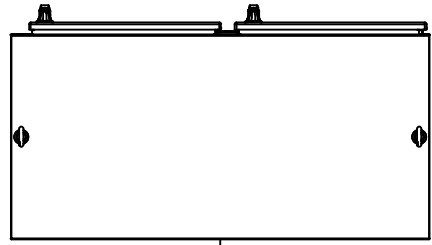

TOP

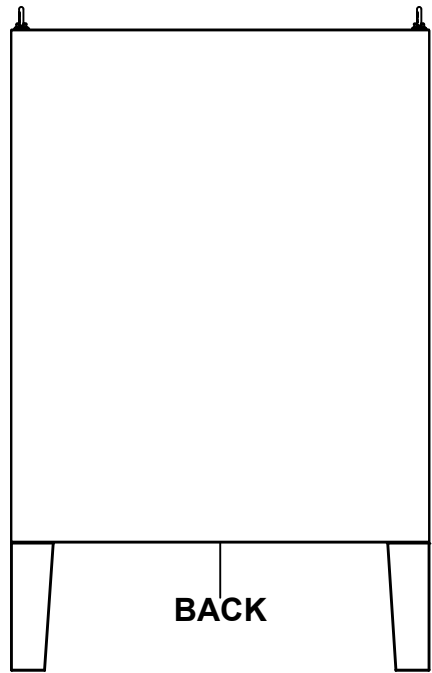

BACK

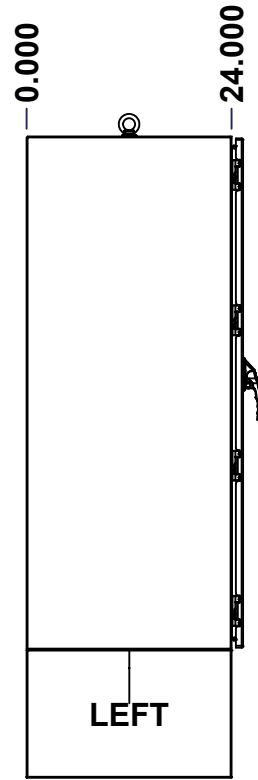

LEFT

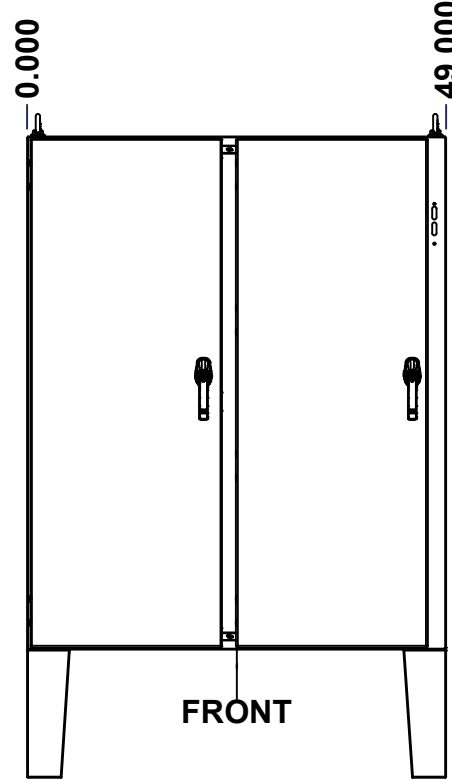

FRONT

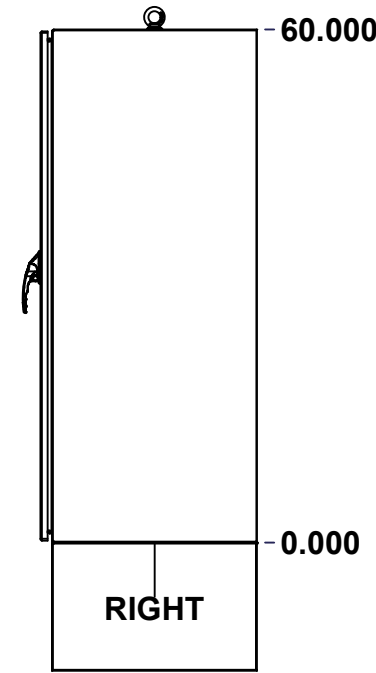

RIGHT

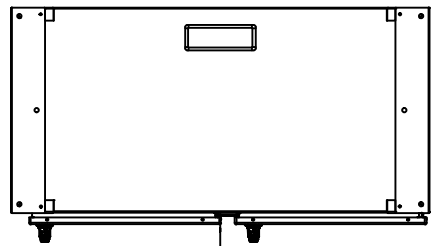

BOTTOM

No.	Revisions	Date	By/Par

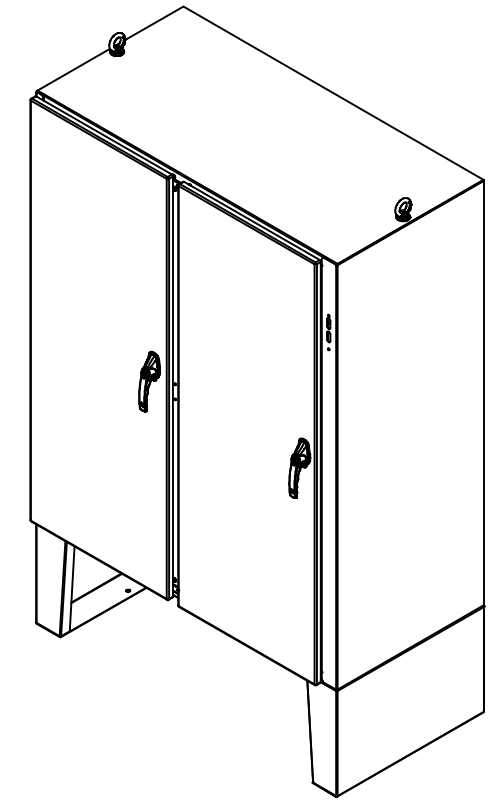

Isometric View



Tél: (450) 979-4373
 Fax: (450) 979-4626
www.exmweb.com

Flatness
Aplatissement

Max 3.0mm

Projection

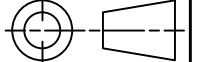

Customer Client	Date
Drawn By / Dessiné Par: BoxCad: BoxCad	Date: 18-Mar-16
Material / Matière: 12 Ga Cold Rolled A1008 CS Type B (2.5mm)	

Color / Couleur: Asa-61 Grey	Finish / Fini: Smooth
------------------------------	-----------------------

Description: 5500UFD 60" x 49" x 24" Assembly	Detail Rev.
---	-------------

Part Number / Numéro Pièce: 5500UFD604924	Rev. 0	1	17
---	--------	---	----

SEE BILL OF MATERIAL ON LAST PAGE

This drawing is confidential and must not be reproduced or used without the consent of EXM

Ce dessin est confidentiel et ne doit pas être reproduit ou utilisé sans le consentement de EXM

NOTE	
ITEM	DESCRIPTION
1	NEMA 12, 13 Enclosure (IP55)
2	C/W Standard ground studs on box and cover
3	C/W Standard door stiffener
4	C/W Standard inner panel (Included)
5	C/W Standard inner panel mounting studs
6	C/W Eyebolts sold separately (Installed by EXM)
7	C/W Mounting feet sold separately (Installed)
8	C/W Struts installed (Included)

No.	Revisions	Date	By/Par

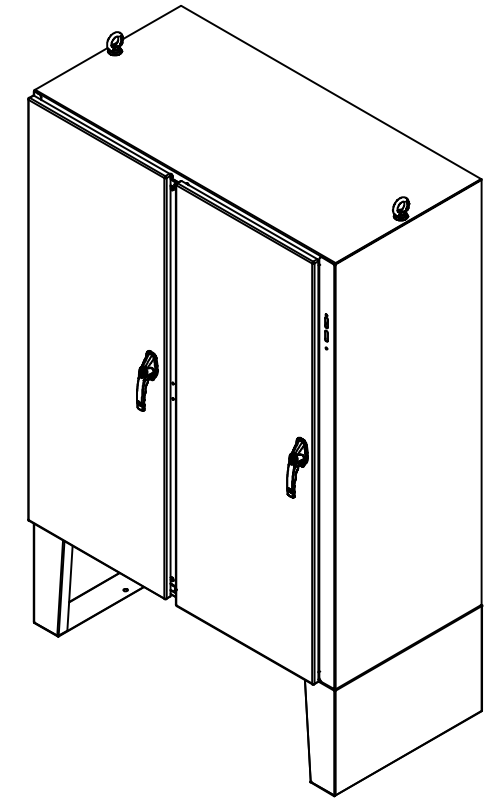

Isometric View

PACKING		
ITEM	QTY	DESCRIPTION
Cardboard sleeve	2	Top and Bottom
Cardboard strip	2	Between back of enclosure and inner panel
Plastic bag	1	To protect cover surface and inside gasket
Cardboard corner	4	To reinforced for the plastic strap tightening
Plastic strap - Black	2	To Squeeze 2 cardboard sleeve together
Packaging label	3	White label with PN
Plastic strap- Green	2	To secure the enclosure to the wood pallet
Wood Pallet	1	2" deeper and 3" larger than enclosure size

1	5500UFD604924MF	0	885 MFHD 15" x 24" Mounting Feet
1	880INTI	4	880 INTI - Interlock Post Kit
1	5500UFD604924GP	0	5500UFD Gland Plate
1	880EB14	2	Eye Bolt M14 (Pack of 2)
8	STK-Q-07320	0	Flange Lock Nut M10
1	885SP6048G	0	885 SP6048G Inner Panel
8	STK-Q-07620	0	M10 Plastic Spacer 0.875"
1	5500UFD604924FD	0	5500UFD 60" x 49" Lock Door
1	5500UFD604924LD	0	5500UFD 60" x 49" Lock Door
1	5500UFD604924B	0	5500UFD 60" x 49" x 24" Body
8	STK-Q-04050-10	8	M6 x 10mm Hexagon Socket Head Machine Screw with Nyseal
Qty	Part Number	Rev	Description
Parts List			

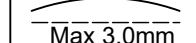
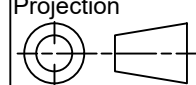
 Tél: (450) 979-4373 Fax: (450) 979-4626 www.exmweb.com		Flatness Aplatissement  Max 3.0mm Projection 
Customer Client	BoxCad: BoxCad	Date 18-Mar-16
Drawn By Dessiné Par	BoxCad: BoxCad	Date 18-Mar-16
Material Matière	12 Ga Cold Rolled A1008 CS Type B (2.5mm)	
Color Couleur	Asa-61 Grey	Finish Fini Smooth
Description	5500UFD 60" x 49" x 24" Assembly	
Part Number Numéro Pièce	5500UFD604924	Rev. 0
		2 / 17

This drawing is confidential and must not be reproduced or used without the consent of EXM

Ce dessin est confidentiel et ne doit pas être reproduit ou utilisé sans le consentement de EXM

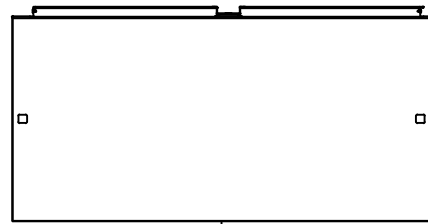

TOP

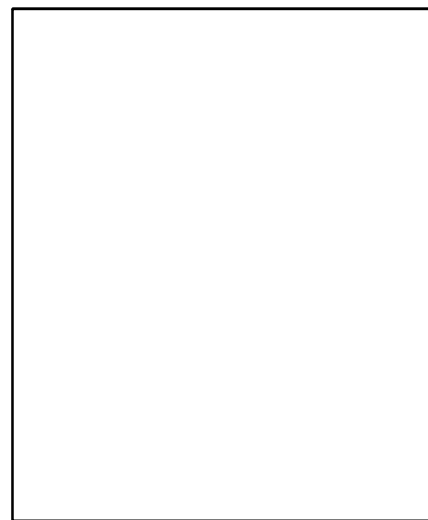

BACK

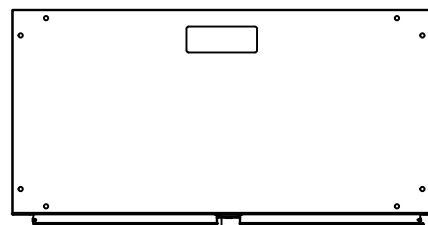

BOTTOM

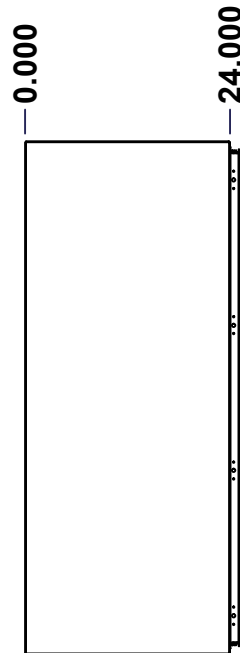

LEFT

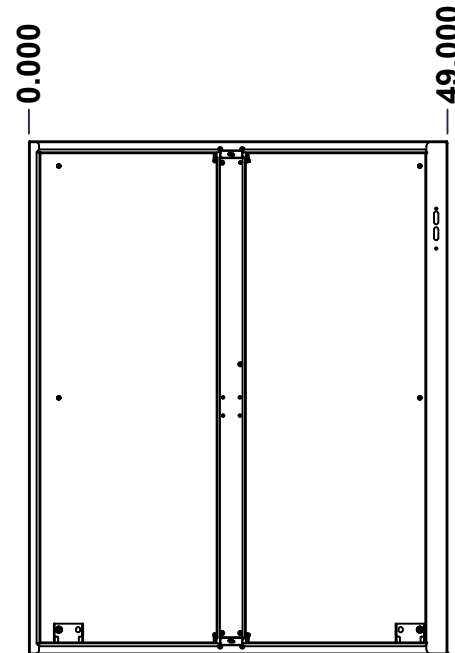

FRONT

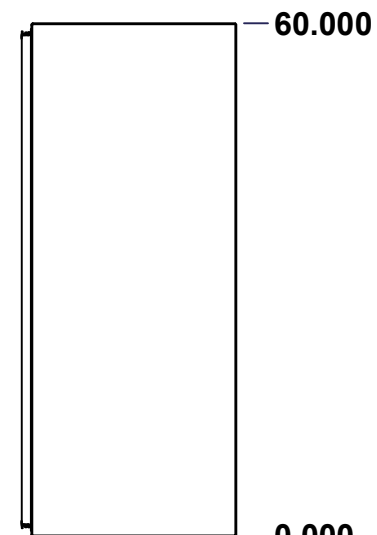

RIGHT

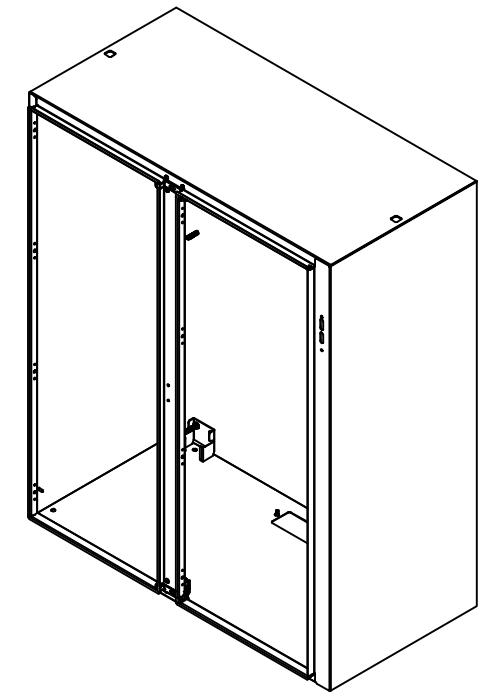

Isometric View

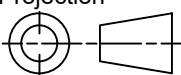

No.	Revisions	Date	By/Par

 Tél: (450) 979-4373 Fax: (450) 979-4626 www.exmweb.com		Flatness Aplatissement Max 3.0mm Projection 
Customer Client	Date	
Drawn By Dessiné Par	BoxCad: BoxCad	Date 18-Mar-16
Material Matière	12 Ga Cold Rolled A1008 CS Type B (2.5mm)	
Color Couleur	Asa-61 Grey	Finish Fini Smooth
Description	Detail Rev.	
5500UFD 60" x 49" x 24" Body		
Part Number Numéro Pièce	Rev. 0	3 / 17

SEE BILL OF MATERIAL ON LAST PAGE

5500UFD604924B

This drawing is confidential and must not be reproduced or used without the consent of EXM

Ce dessin est confidentiel et ne doit pas être reproduit ou utilisé sans le consentement de EXM

STANDARD FEATURES ARE NOT LISTED IN THIS HOLE TABLE

HOLE TABLE - TOP VIEW (CUSTOM FEATURE ONLY)

CUT-OUT	XDIM	YDIM	DESCRIPTION
1	11.911	19.911	Struts CR400 17.500" (Inside)
2	36.911	19.911	Struts CR400 17.500" (Inside)
3	11.911	20.840	STUDS M6 x 10mm (Inside)
4	20.777	19.911	STUDS M6 x 10mm (Inside)
5	36.911	20.840	STUDS M6 x 10mm (Inside)
6	45.777	19.911	STUDS M6 x 10mm (Inside)

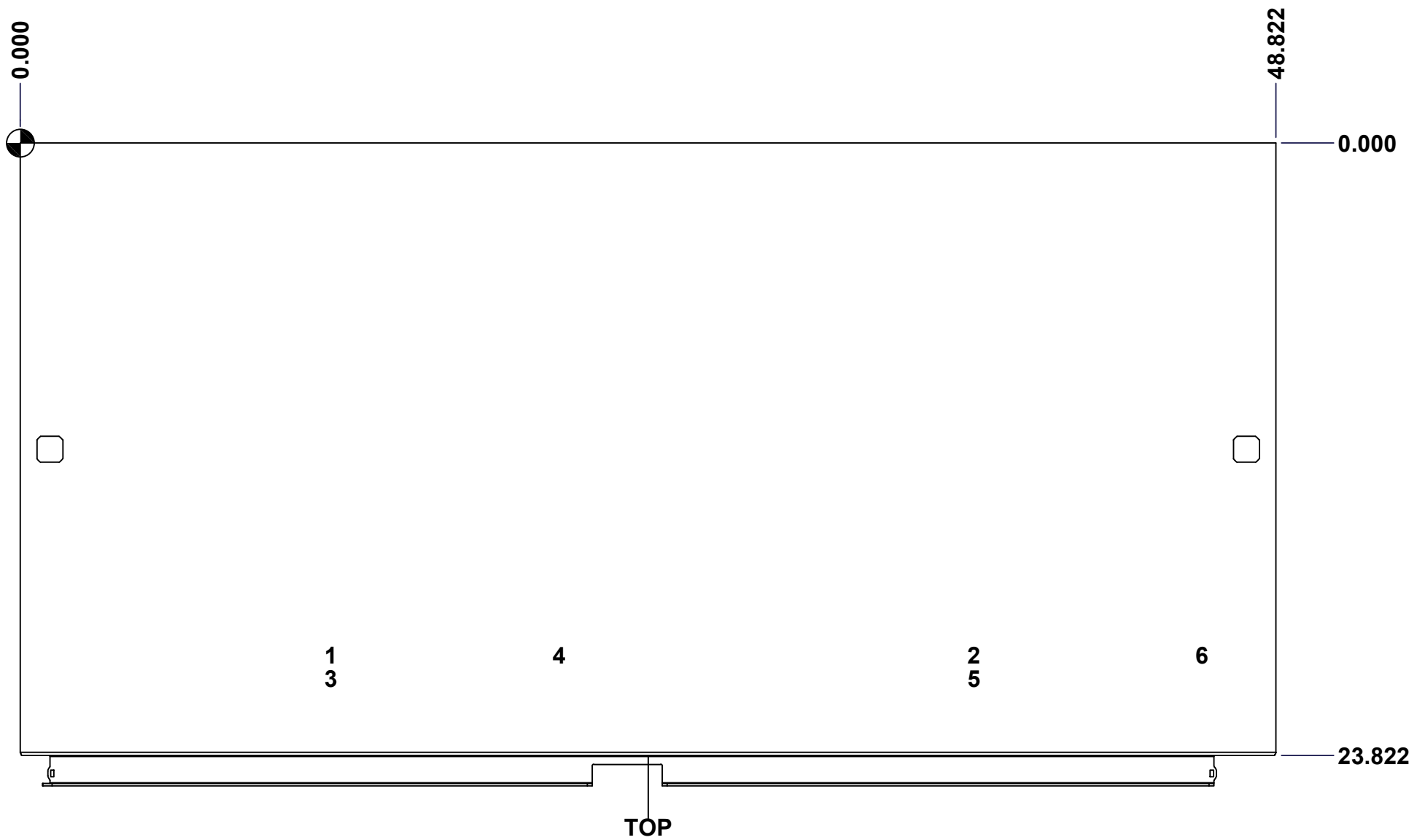

	Description	Status
	5500UFD 60" x 49" x 24" Body	(NULL)
	Part Number Numéro Pièce	Rev.
	5500UFD604924B	0
		4
		17

This drawing is confidential and must not be reproduced or used without the consent of EXM

Ce dessin est confidentiel et ne doit pas être reproduit ou utilisé sans le consentement de EXM

STANDARD FEATURES ARE NOT LISTED IN THIS HOLE TABLE

HOLE TABLE - BOTTOM VIEW (CUSTOM FEATURE ONLY)

CUT-OUT	XDIM	YDIM	DESCRIPTION
1	19.786	3.411	GP STUD M6 x 16mm (Inside)
2	29.036	3.411	GP STUD M6 x 16mm (Inside)

3	3.911	0.911	RND Ø0.500
4	0.911	2.911	RND Ø0.500
5	0.911	20.911	RND Ø0.500
6	3.911	22.911	RND Ø0.500
7	44.911	0.911	RND Ø0.500
8	47.911	2.911	RND Ø0.500
9	47.911	20.911	RND Ø0.500
10	44.911	22.911	RND Ø0.500

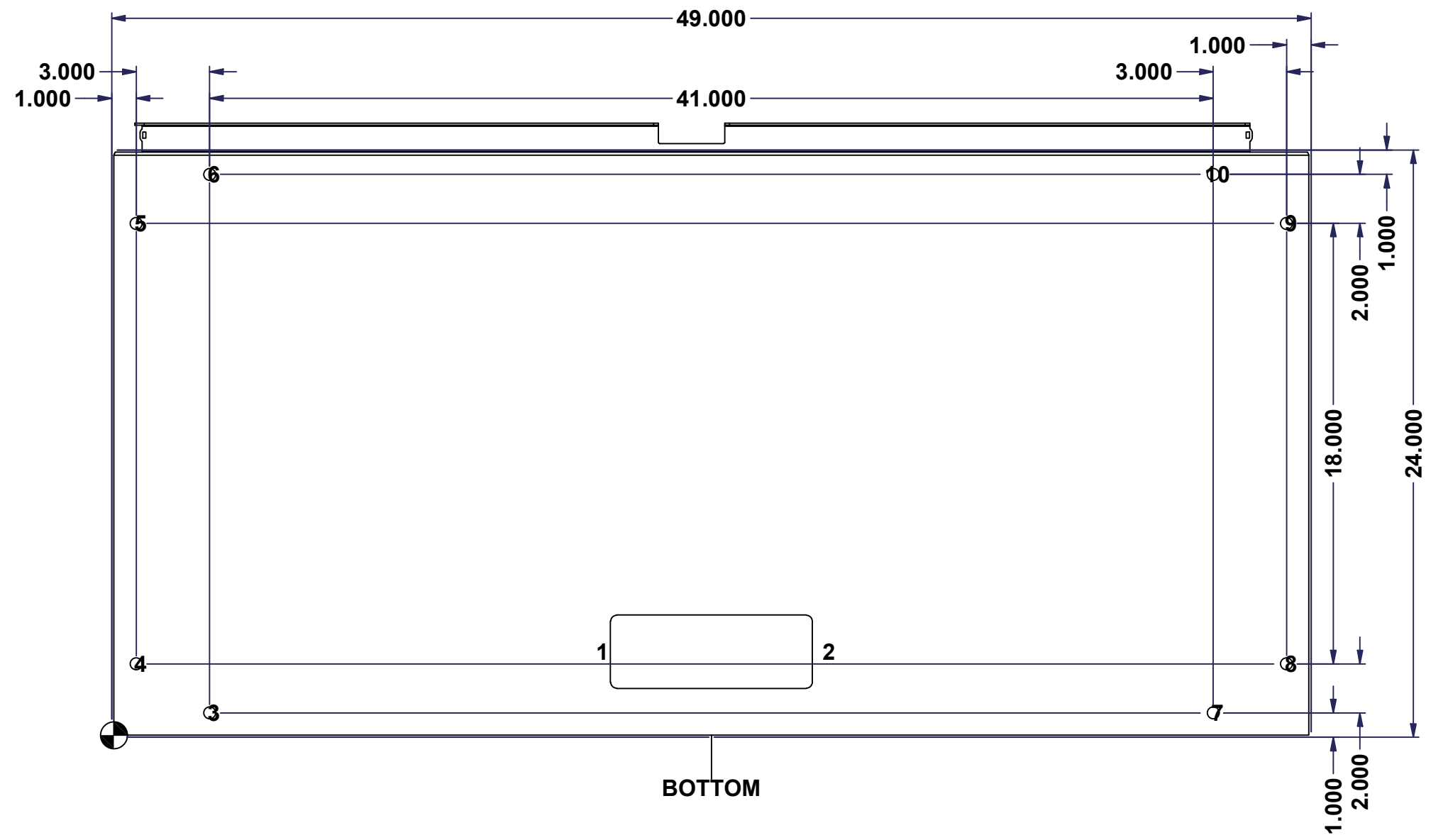

BOTTOM

	Description	Status
	5500UFD 60" x 49" x 24" Body	(NULL)
	Part Number Numéro Pièce	Rev.
	5500UFD604924B	0
		5
		17

This drawing is confidential and must not be reproduced or used without the consent of EXM

Ce dessin est confidentiel et ne doit pas être reproduit ou utilisé sans le consentement de EXM

STANDARD FEATURES ARE NOT LISTED IN THIS HOLE TABLE			
HOLE TABLE - LEFT VIEW (CUSTOM FEATURE ONLY)			
CUT-OUT	XDIM	YDIM	DESCRIPTION
1	22.411	3.286	GND STUD M6 x 16mm (Inside)

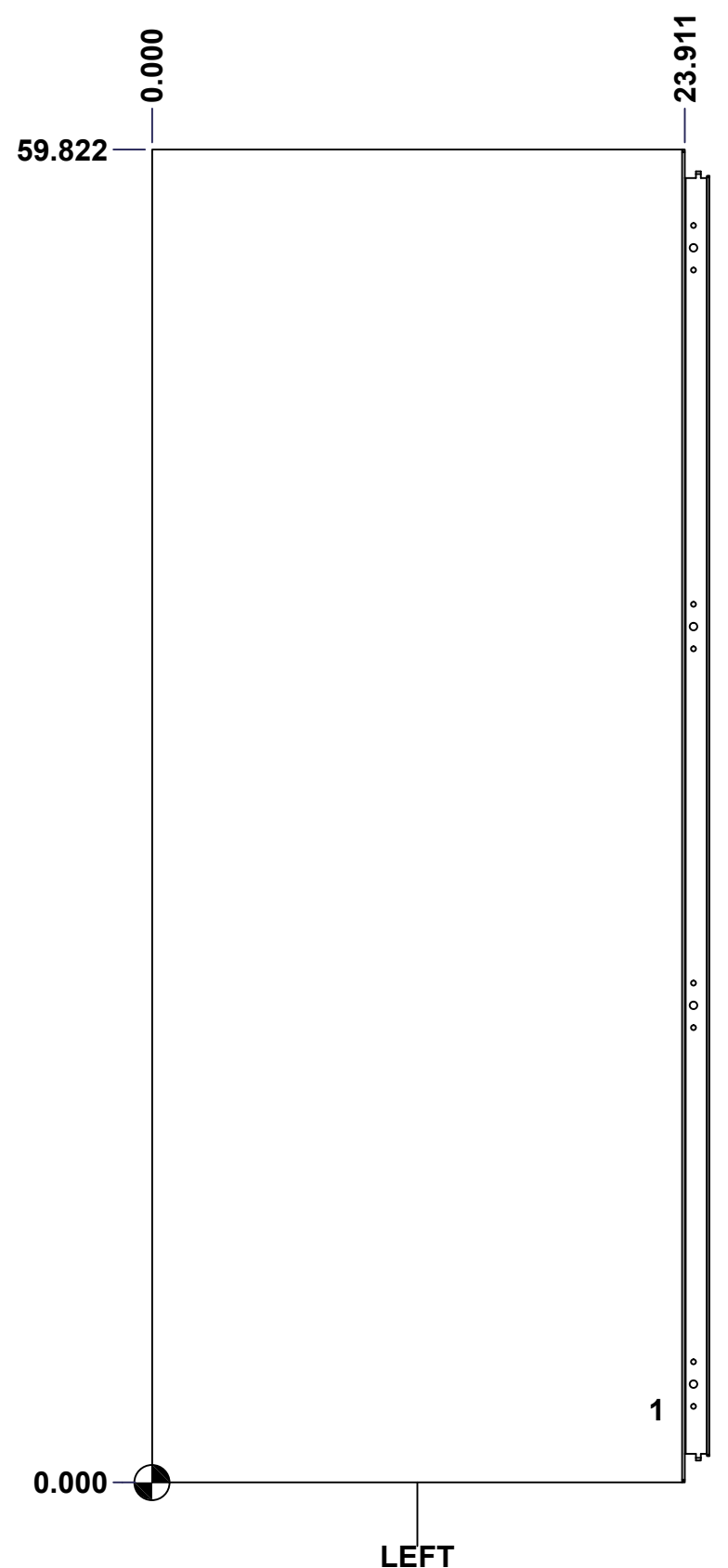

	Description	Status
	5500UFD 60" x 49" x 24" Body	(NULL)
Part Number Numéro Pièce 5500UFD604924B	Rev.	6
	0	17

This drawing is confidential and must not be reproduced or used without the consent of EXM

Ce dessin est confidentiel et ne doit pas être reproduit ou utilisé sans le consentement de EXM

STANDARD FEATURES ARE NOT LISTED IN THIS HOLE TABLE

HOLE TABLE - BACK VIEW (CUSTOM FEATURE ONLY)

CUT-OUT	XDIM	YDIM	DESCRIPTION
1	3.161	2.786	IP STUD M10 x 40mm (Inside)
2	45.411	2.786	IP STUD M10 x 40mm (Inside)
3	3.161	29.911	IP STUD M10 x 40mm (Inside)
4	45.411	29.911	IP STUD M10 x 40mm (Inside)
5	3.161	57.036	IP STUD M10 x 40mm (Inside)
6	45.411	57.036	IP STUD M10 x 40mm (Inside)
7	24.286	2.786	IP STUD M10 x 40mm (Inside)
8	24.286	57.036	IP STUD M10 x 40mm (Inside)

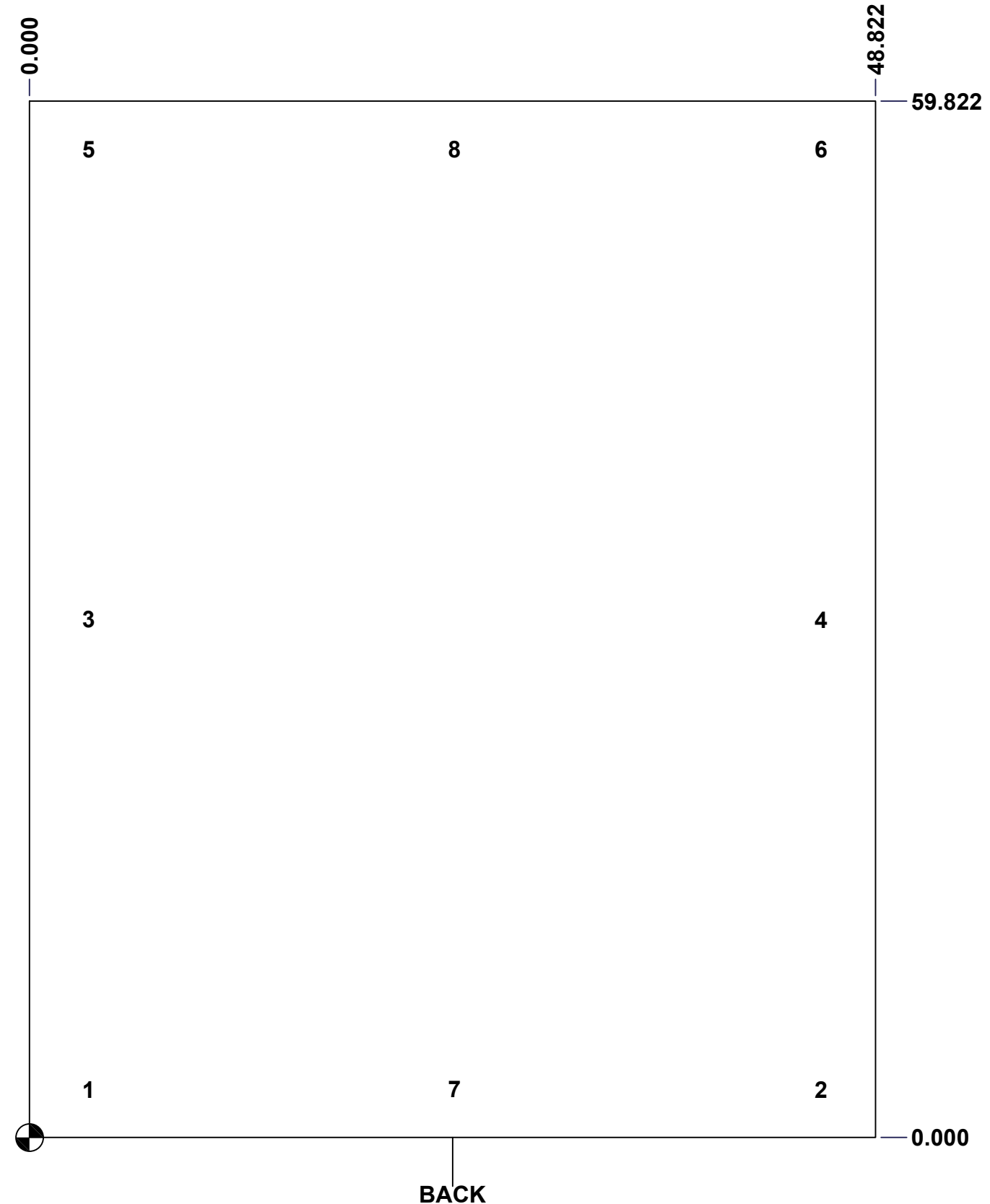

	Description	Status
	5500UFD 60" x 49" x 24" Body	(NULL)
	Part Number Numéro Pièce	Rev.
	5500UFD604924B	0 / 7
		17

This drawing is confidential and must not be reproduced or used without the consent of EXM

Ce dessin est confidentiel et ne doit pas être reproduit ou utilisé sans le consentement de EXM

STANDARD FEATURES ARE NOT LISTED IN THIS HOLE TABLE

HOLE TABLE - CENTER VIEW (CUSTOM FEATURE ONLY)

CUT-OUT	XDIM	YDIM	DESCRIPTION
1	1.732	3.648	GND STUD M6 x 16mm (Inside)

2	0.748	26.179	PEM FH-M6-15ZI (Inside)
3	0.748	28.305	PEM FH-M6-15ZI (Inside)
4	2.717	26.179	PEM FH-M6-15ZI (Inside)
5	2.717	28.305	PEM FH-M6-15ZI (Inside)

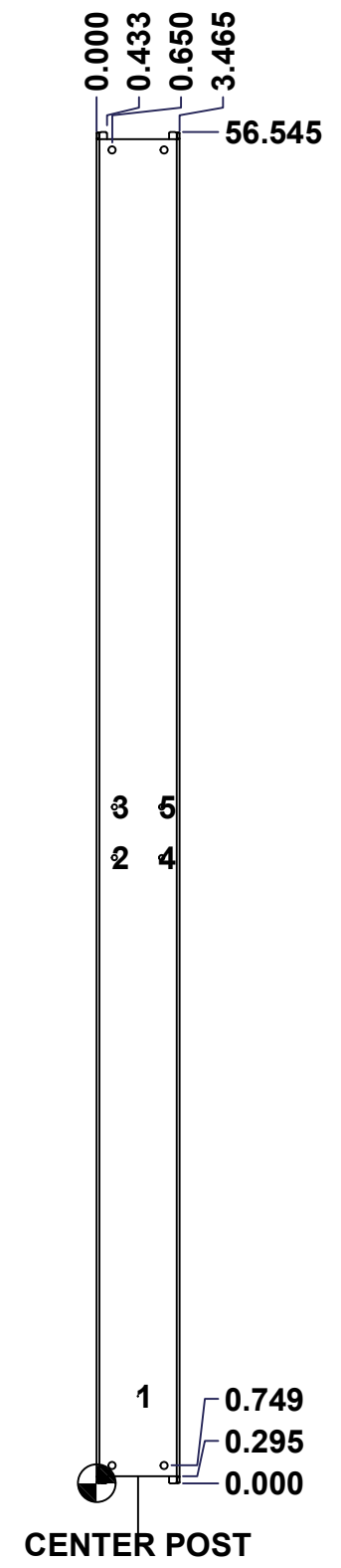

	Description	Status
	5500UFD 60" x 49" x 24" Body	(NULL)
	Part Number Numéro Pièce	Rev.
	5500UFD604924B	0 / 8
		17

This drawing is confidential and must not be reproduced or used without the consent of EXM

Ce dessin est confidentiel et ne doit pas être reproduit ou utilisé sans le consentement de EXM

No.	Revisions	Date	By/Par

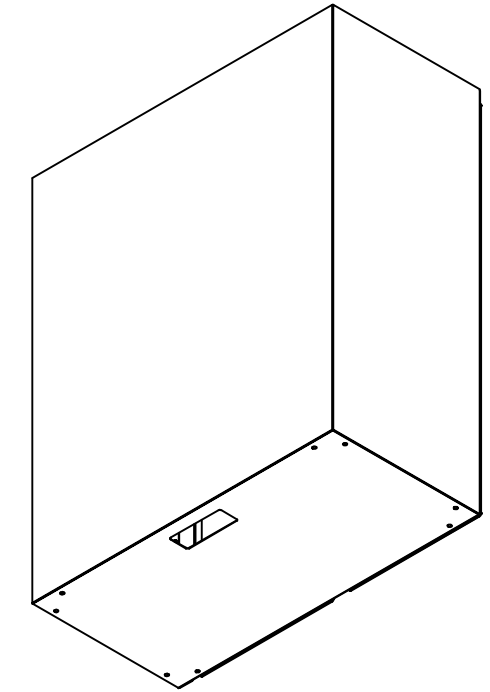

Isometric View



4	STK-Q-16030	0	Stud M6 x 10mm Steel
4	STK-PEM-FH-M6-15ZI	0	PEM Self-Clinching Stud M6 x 15.0mm
2	STK-Q-74910	0	Eyebolt Lifting Angle (15.500")
1	STK-P-02400S	0	Powder Paint (Asa-61 Grey / Smooth)
1	STK-A-75454	3	Center Post - Sealing Block with Latch Assembly (Large)
1	5500UFD604924CP-P	0	5500UFD 60" Center Post Part
2	STK-Q-07320	0	Flange Lock Nut M10
2	STK-Q-07618	1	5500 Series Inner Panel Support Bracket
8	STK-Q-16100	0	Stud M10 x 40mm Steel
1	5500UFD604924BT-P	0	5500UFD 49" x 24" Bottom Part
1	5500UFD604924T-P	0	5500UFD 49" x 24" Top Part
1	5500UFD604924RS-P	0	5500UFD 60" x 49" Right Part
1	5500UFD604924LS-P	0	5500UFD 60" x 49" Left Part
1	5500UFD604924B-P	0	5500UFD 60" x 49" Back Part
2	5500UFD604924_CR400 MS_17.5	0	Commercial Roll Mild Steel (17.5in long)
4	STK-Q-16080	0	Ground Stud M6 x 16mm Steel

Qty	Part Number	Rev	Description
Parts List			

Tél: (450) 979-4373 Fax: (450) 979-4626 www.exmweb.com	Flatness Aplatissement	Max 3.0mm
	Projection	
Customer Client	Date	
Drawn By Dessiné Par	BoxCad: BoxCad	Date 18-Mar-16
Material Matière	12 Ga Cold Rolled A1008 CS Type B (2.5mm)	
Color Couleur	Asa-61 Grey	Finish Fini Smooth
Description	Detail Rev.	
5500UFD 60" x 49" x 24" Body		
Part Number Numéro Pièce	Rev.	9
5500UFD604924B	0	17

This drawing is confidential and must not be reproduced or used without the consent of EXM

Ce dessin est confidentiel et ne doit pas être reproduit ou utilisé sans le consentement de EXM

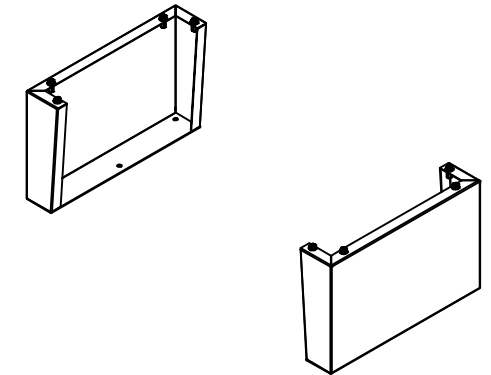
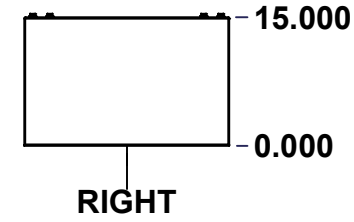
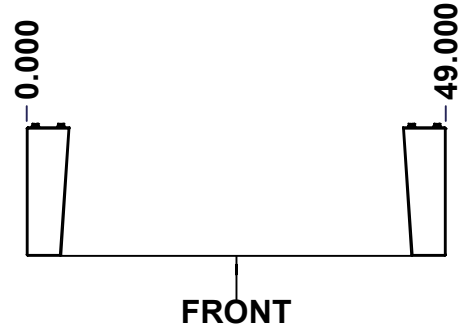
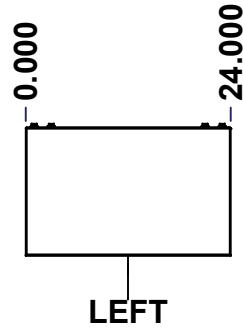
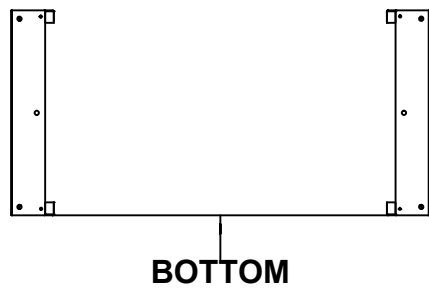
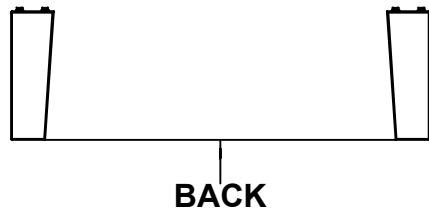
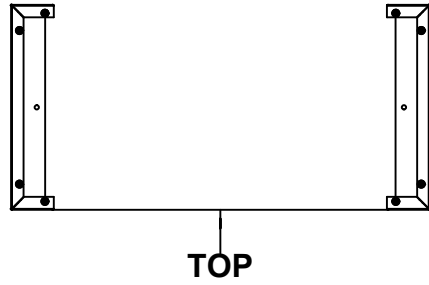

No.	Revisions	Date	By/Par

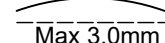
 Tél: (450) 979-4373 Fax: (450) 979-4626 www.exmweb.com		Flatness Aplatissement  Max 3.0mm
Customer Client		Date
Drawn By Dessiné Par BoxCad: BoxCad		Date 18-Mar-16
Material Matière 12 Ga Cold Rolled A1008 CS Type B (2.5mm)		
Color Couleur Asa-61 Grey	Finish Fini Smooth	
Description 885 MFHD 15" x 24" Mounting Feet		Detail Rev.
Part Number Numéro Pièce 5500UFD604924MF		Rev. 10 0

SEE BILL OF MATERIAL ON LAST PAGE

This drawing is confidential and must not be reproduced or used without the consent of EXM

Ce dessin est confidentiel et ne doit pas être reproduit ou utilisé sans le consentement de EXM

No.	Revisions	Date	By/Par

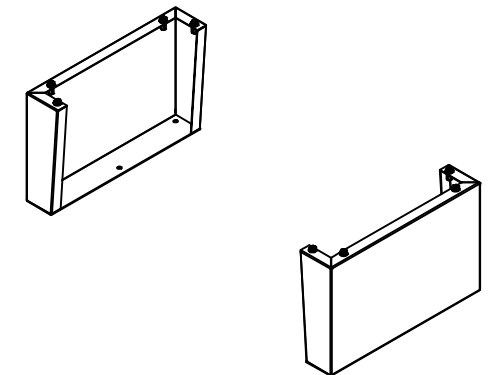

Isometric View

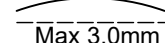
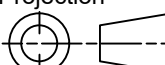

 Tél: (450) 979-4373 Fax: (450) 979-4626 www.exmweb.com		Flatness Aplatissement  Max 3.0mm Projection 
Customer Client	Date	
Drawn By Dessiné Par	BoxCad: BoxCad	Date 18-Mar-16
Material Matière	12 Ga Cold Rolled A1008 CS Type B (2.5mm)	
Color Couleur	Asa-61 Grey	Finish Fini Smooth
Description		Detail Rev.
885 MFHD 15" x 24" Mounting Feet		
Part Number Numéro Pièce	Rev.	11
5500UFD604924MF	0	17

Qty	Part Name	Rev	Description
1	STK-P-02400S	0	Powder Paint (Asa-61 Grey / Smooth)
8	RIVET_NUT_M10_FH_CE	0	Rivet Nut M10 (Low Profile Close End)
1	5500UFD604924MFR-P	0	885 MFHD 15" x 24" Right Mounting Feet Part
1	5500UFD604924MFL-P	0	885 MFHD 15" x 24" Left Mounting Feet Part
4	STK-K-11600	2	885 MF Accessory Kit
Parts List			

This drawing is confidential and must not be reproduced or used without the consent of EXM

Ce dessin est confidentiel et ne doit pas être reproduit ou utilisé sans le consentement de EXM

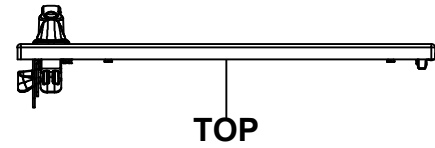

TOP

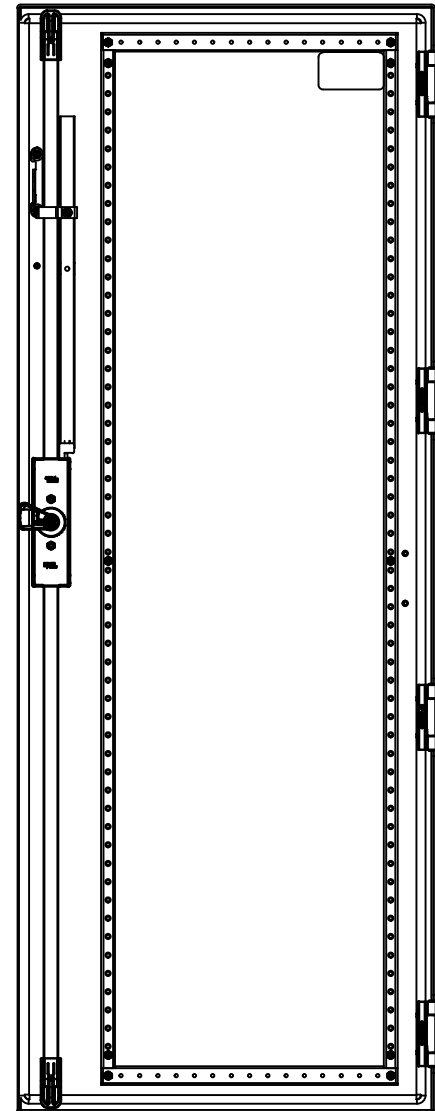

BACK



BOTTOM

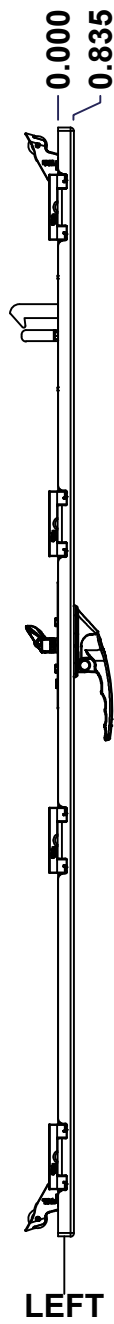

LEFT

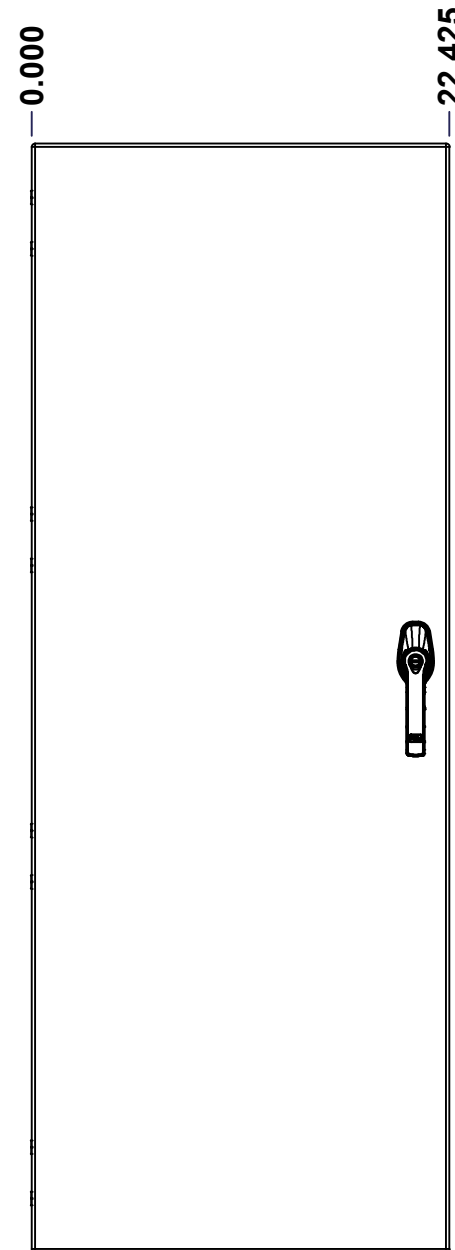

FRONT

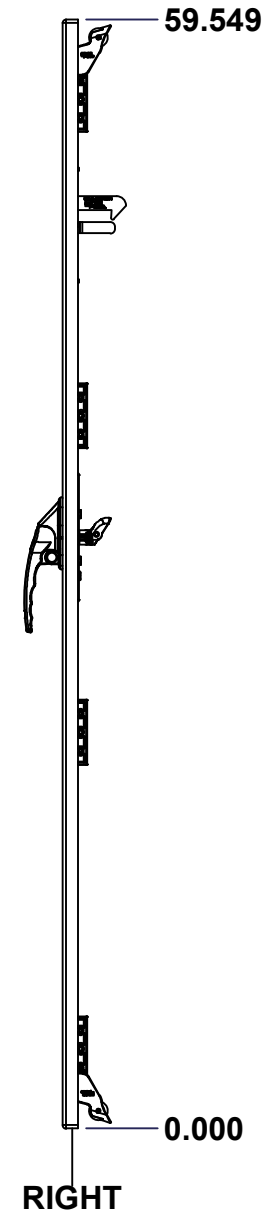

RIGHT

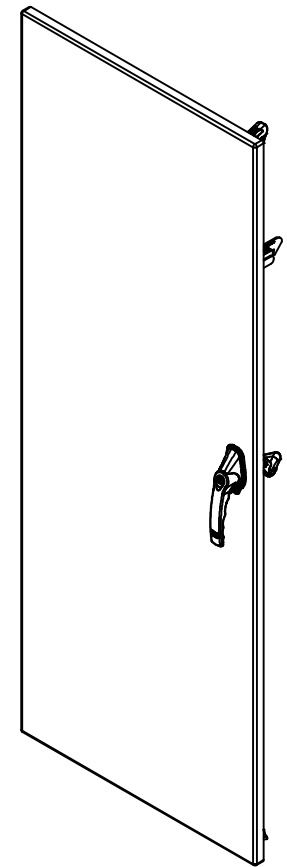

Isometric View



No.	Revisions	Date	By/Par

 Tél: (450) 979-4373 Fax: (450) 979-4626 www.exmweb.com		Flatness Aplatissement	
		Max 3.0mm	
Customer Client		Date	
Drawn By Dessiné Par BoxCad: BoxCad		Date 18-Mar-16	
Material Matière 12 Ga Cold Rolled A1008 CS Type B (2.5mm)			
Color Couleur Asa-61 Grey		Finish Fini Smooth	
Description 5500UFD 60" x 49" Lock Door			Detail Rev.
Part Number Numéro Pièce 5500UFD604924LD		Rev. 0	12 / 17

SEE BILL OF MATERIAL ON LAST PAGE

This drawing is confidential and must not be reproduced or used without the consent of EXM

Ce dessin est confidentiel et ne doit pas être reproduit ou utilisé sans le consentement de EXM

STANDARD FEATURES ARE NOT LISTED IN THIS HOLE TABLE			
HOLE TABLE - FRONT VIEW (CUSTOM FEATURE ONLY)			
CUT-OUT	XDIM	YDIM	DESCRIPTION
1	2.375	2.028	STUD M6 x 18mm (Inside)
2	2.375	29.675	STUD M6 x 18mm (Inside)
3	2.375	57.521	STUD M6 x 18mm (Inside)
4	2.375	3.139	STUD M6 x 18mm (Inside)
5	2.375	56.409	STUD M6 x 18mm (Inside)
6	17.544	2.028	STUD M6 x 18mm (Inside)
7	17.544	29.675	STUD M6 x 18mm (Inside)
8	17.544	57.521	STUD M6 x 18mm (Inside)
9	17.544	3.139	STUD M6 x 18mm (Inside)
10	17.544	56.409	STUD M6 x 18mm (Inside)
11	21.380	51.511	STUD M6 x 18mm (Inside)
12	21.380	48.511	STUD M6 x 18mm (Inside)
13	21.380	45.511	STUD M6 x 18mm (Inside)
14	20.603	6.179	LARGE CBAR GUIDE (Inside)
15	20.603	53.370	LARGE CBAR GUIDE (Inside)
16	19.747	51.870	LARGE CBAR GUIDE (Inside)
-----	-----	-----	-----
17	20.613	31.743	HANDLE 885 ESL2A-APHD @ 0.0°
18	1.610	27.404	STUDS M6 x 18mm (Inside)
19	1.610	30.082	STUDS M6 x 18mm (Inside)

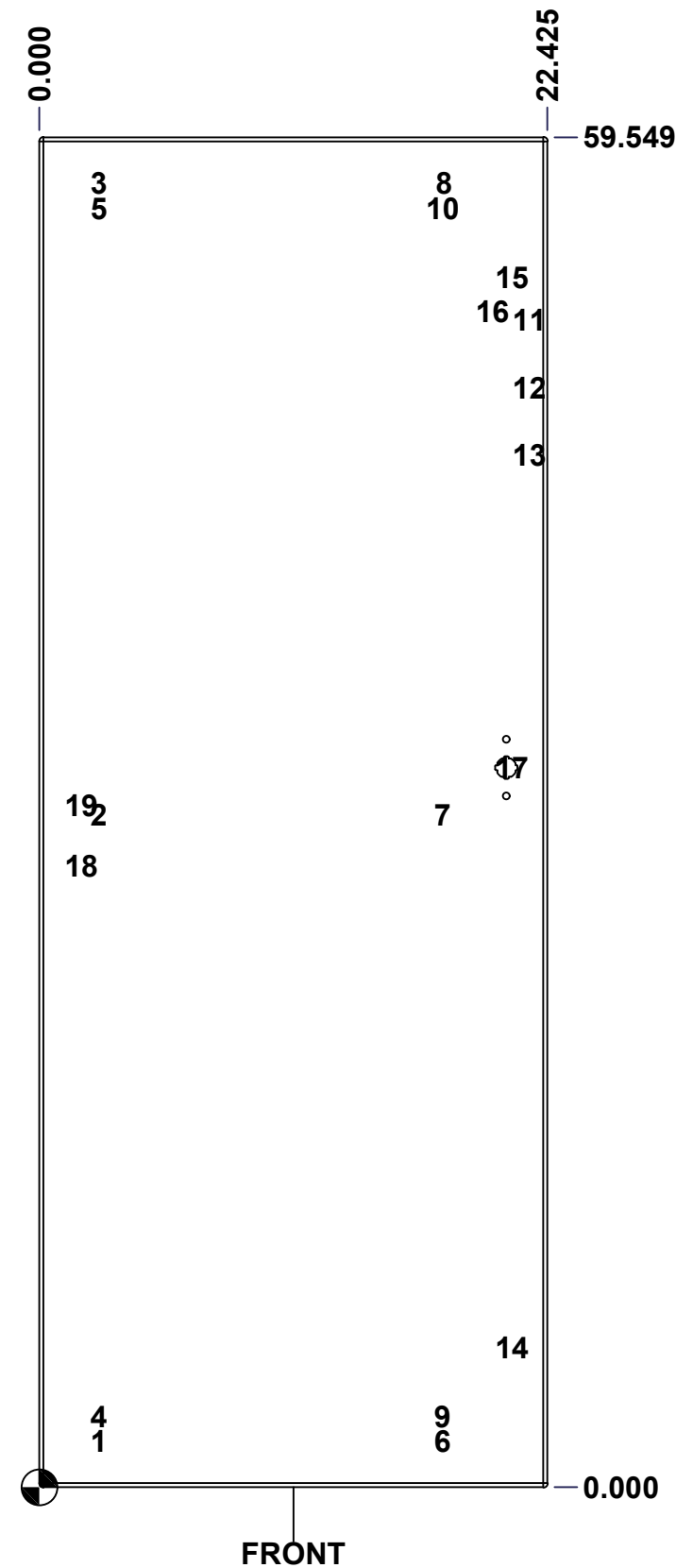

	Description	Status
	5500UFD 60" x 49" Lock Door	(NULL)
	Part Number Numéro Pièce	Rev.
	5500UFD604924LD	0 / 13
		17

This drawing is confidential and must not be reproduced or used without the consent of EXM

Ce dessin est confidentiel et ne doit pas être reproduit ou utilisé sans le consentement de EXM

No.	Revisions	Date	By/Par

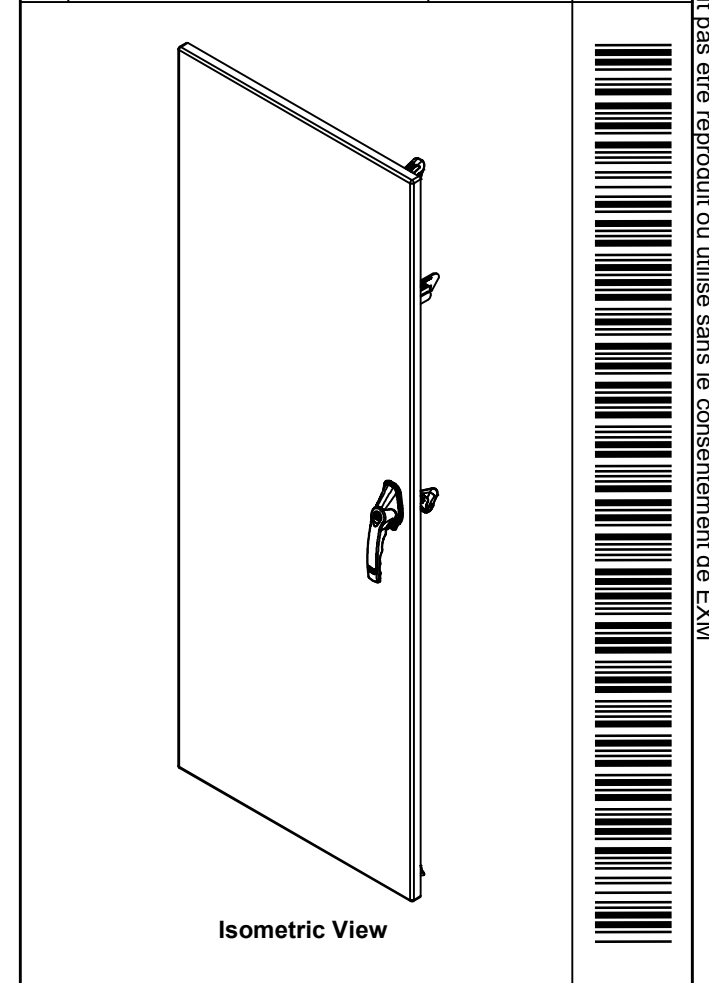

EXM
exm

Tél: (450) 979-4373
Fax: (450) 979-4626
www.exmweb.com

Flatness
Aplatissement
Max 3.0mm

Projection

1	STK-K-55060	0	5500 UCD and UFD 60" Locking Mechanism Kit
2	STK-Q-16050	1	Stud M6 x 18mm Steel
1	885ESL2A-APHD	1	885 ESL2A-APHD - Zinc Die Cast L-Handle Padlockable Assy - Slot Cylinder
1	STK-P-02400S	0	Powder Paint (Asa-61 Grey / Smooth)
1	STK-S-00100	0	3.5" x 2" Silver Milar Flexcon Sticker
1	5500UFD604924DS1	0	5500UFD 60" x 49" Door Stiffener
3	STK-Q-16410	0	Guide Stud - Largel (No Paint Cap Required)
13	STK-Q-16055	1	M6 x 18mm Stud (No Paint Cap Required)
1	5500UFD604924LDG	0	5500UFD 60" x 49" Lock Door Gasket
1	5500UFD604924LD-P	0	5500UFD 60" x 49" Lock Door Part
4	STK-K-09860	7	Cabinet Hinge with Captive Pins
QTY	Part Number	Rev	Description
Parts List			

Customer Client	Date
Drawn By Dessiné Par BoxCad: BoxCad	Date 18-Mar-16
Material Matière 12 Ga Cold Rolled A1008 CS Type B (2.5mm)	
Color Couleur Asa-61 Grey	Finish Fini Smooth
Description 5500UFD 60" x 49" Lock Door	Detail Rev.
Part Number Numéro Pièce 5500UFD604924LD	Rev. 0
	14 17

This drawing is confidential and must not be reproduced or used without the consent of EXM

Ce dessin est confidentiel et ne doit pas être reproduit ou utilisé sans le consentement de EXM

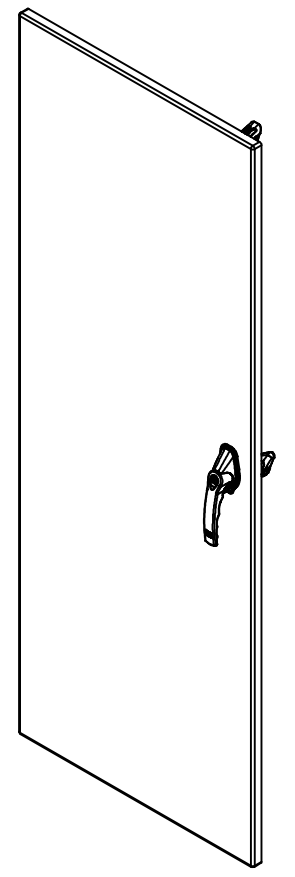
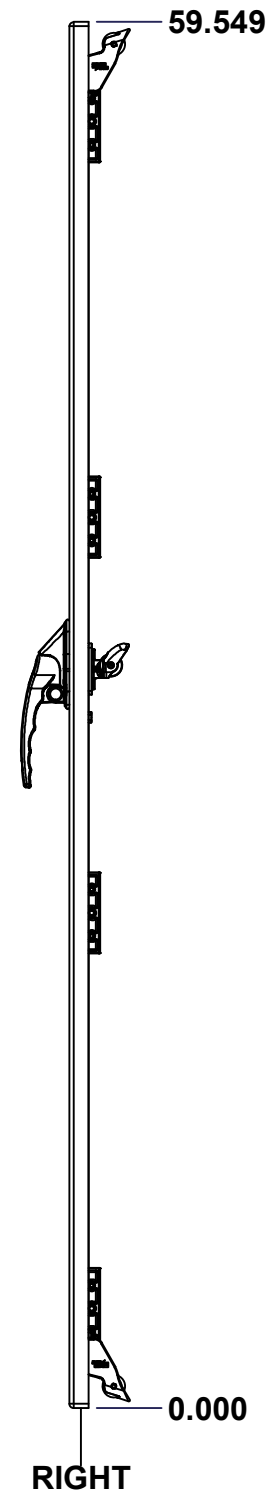
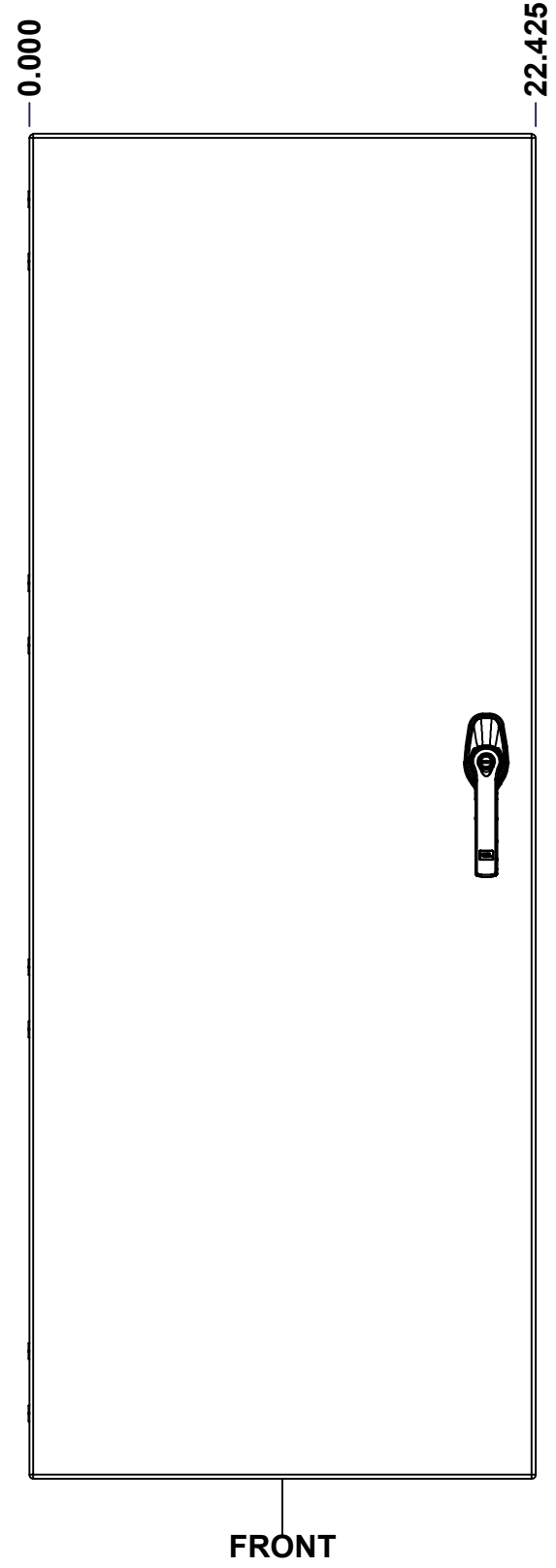
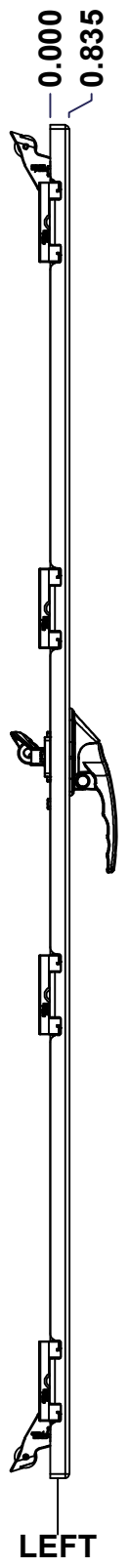
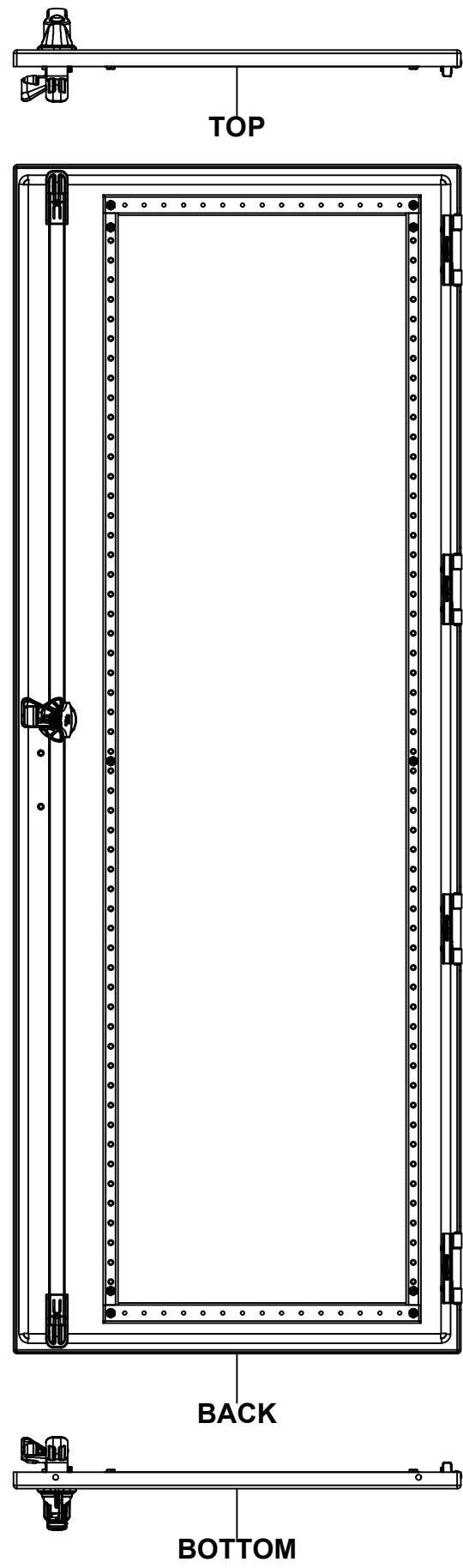

Isometric View

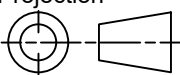

No.	Revisions	Date	By/Par

 Tél: (450) 979-4373 Fax: (450) 979-4626 www.exmweb.com		Flatness Aplatissement Max 3.0mm Projection 
Customer Client	Date	
Drawn By Dessiné Par	BoxCad: BoxCad	Date 18-Mar-16
Material Matière	12 Ga Cold Rolled A1008 CS Type B (2.5mm)	
Color Couleur	Asa-61 Grey	Finish Fini Smooth
Description	Detail Rev.	
5500UFD 60" x 49" Lock Door		
Part Number Numéro Pièce	Rev. 0	15 / 17

SEE BILL OF MATERIAL ON LAST PAGE

5500UFD604924FD

This drawing is confidential and must not be reproduced or used without the consent of EXM

Ce dessin est confidentiel et ne doit pas être reproduit ou utilisé sans le consentement de EXM

STANDARD FEATURES ARE NOT LISTED IN THIS HOLE TABLE

HOLE TABLE - FRONT VIEW (CUSTOM FEATURE ONLY)

CUT-OUT	XDIM	YDIM	DESCRIPTION
1	2.375	2.028	STUD M6 x 18mm (Inside)
2	2.375	29.581	STUD M6 x 18mm (Inside)
3	2.375	57.521	STUD M6 x 18mm (Inside)
4	2.375	3.139	STUD M6 x 18mm (Inside)
5	2.375	56.409	STUD M6 x 18mm (Inside)
6	17.544	2.028	STUD M6 x 18mm (Inside)
7	17.544	29.581	STUD M6 x 18mm (Inside)
8	17.544	57.521	STUD M6 x 18mm (Inside)
9	17.544	3.139	STUD M6 x 18mm (Inside)
10	17.544	56.409	STUD M6 x 18mm (Inside)
11	20.238	6.118	LARGE GUIDE STUD (Inside)
12	20.238	53.431	LARGE GUIDE STUD (Inside)
-----	-----	-----	-----
13	20.238	31.743	HANDLE 885 ESL2A-APHD
14	21.043	27.404	STUDS M6 x 18mm (Inside)
15	21.043	30.082	STUDS M6 x 18mm (Inside)

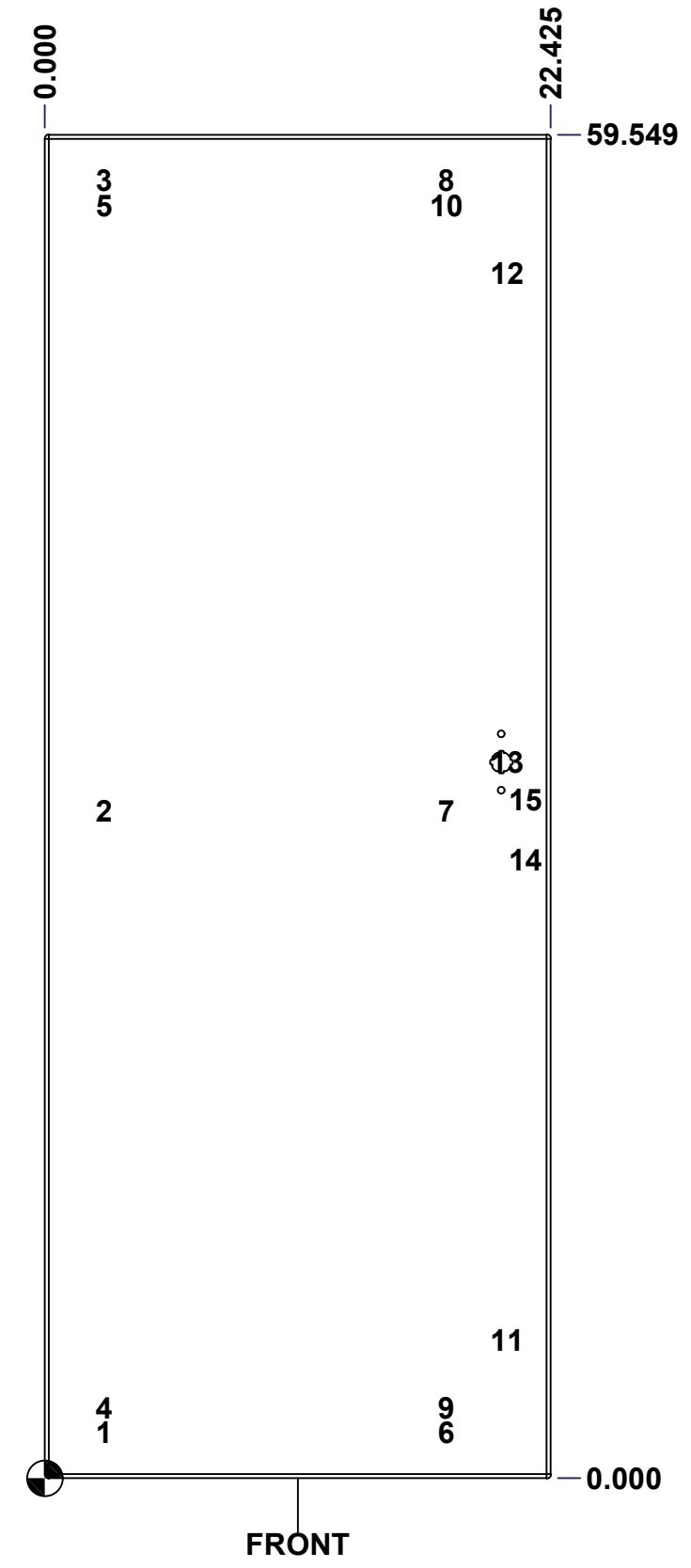

	Description	Status
	5500UFD 60" x 49" Lock Door	(NULL)
	Part Number Numéro Pièce	Rev.
	5500UFD604924FD	0 / 16
		17

This drawing is confidential and must not be reproduced or used without the consent of EXM

Ce dessin est confidentiel et ne doit pas être reproduit ou utilisé sans le consentement de EXM

No.	Revisions	Date	By/Par

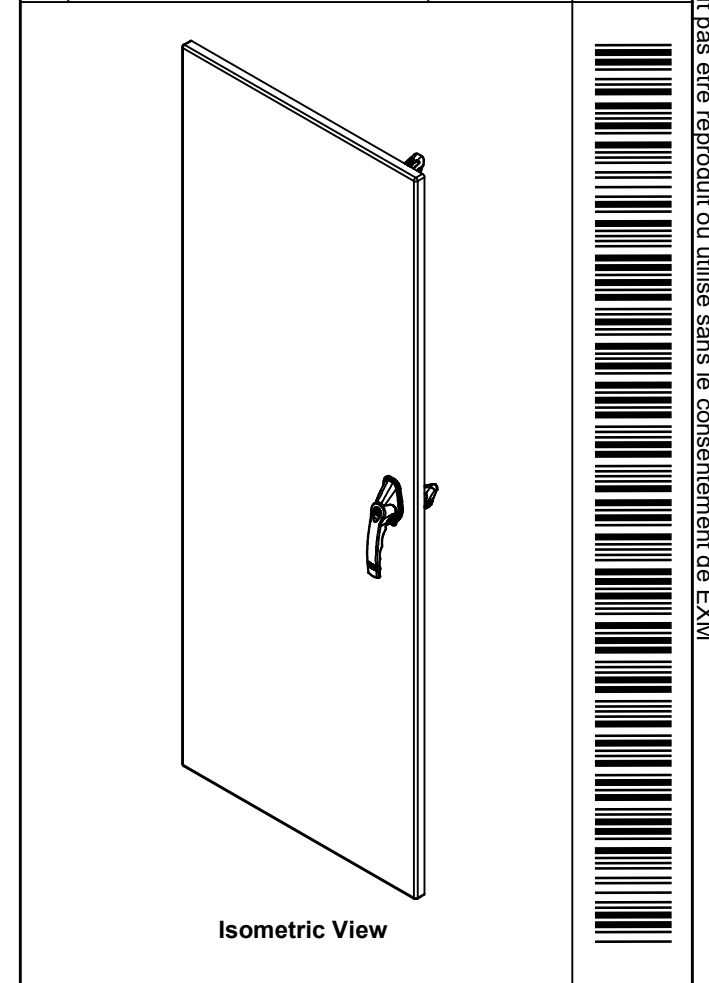

2	STK-Q-16050	1	Stud M6 x 18mm Steel
1	STK-Q-47541	1	5500 DDS Lower Closing Bar 60"
1	STK-Q-47531	0	5500 DDS Upper Closing Bar 60"
1	STK-A-50538	3	9500 Handle Cam Assembly (Right Side, Grip 36mm)
1	STK-Q-90051	3	5412 ES - Handle Cam Spacer
1	885ESL2A-APHD	1	885 ESL2A-APHD - Zinc Die Cast L-Handle Padlockable Assy - Slot Cylinder
1	STK-P-02400S	0	Powder Paint (Asa-61 Grey / Smooth)
1	5500UFD604924DS1	0	5500UFD 60" x 49" Door Stiffener
2	STK-Q-16410	0	Guide Stud - Larget (No Paint Cap Required)
10	STK-Q-16055	1	M6 x 18mm Stud (No Paint Cap Required)
1	5500UFD604924FDG	0	5500UFD 60" x 49" Flange Door Gasket
1	5500UFD604924FD-P	0	5500UFD 60" x 49" Lock Door Part
2	STK-A-90025	0	9500 - Cabinet Closing Bar End (Large)
4	STK-K-09860	7	Cabinet Hinge with Captive Pins
2	STK-Q-07220	1	M6 Nylon Insert Lock Nut

QTY	Part Number	Rev	Description
Parts List			

<p>Tél: (450) 979-4373 Fax: (450) 979-4626 www.exmweb.com</p>	Flatness Aplatissement	Max 3.0mm
	Projection	
Customer Client	Date	
Drawn By Dessiné Par	BoxCad: BoxCad	Date 18-Mar-16
Material Matière	12 Ga Cold Rolled A1008 CS Type B (2.5mm)	
Color Couleur	Asa-61 Grey	Finish Fini Smooth
Description	5500UFD 60" x 49" Lock Door	
Part Number Numéro Pièce	Rev. 0	17 / 17
5500UFD604924FD		

This drawing is confidential and must not be reproduced or used without the consent of EXM

Ce dessin est confidentiel et ne doit pas être reproduit ou utilisé sans le consentement de EXM



TOP

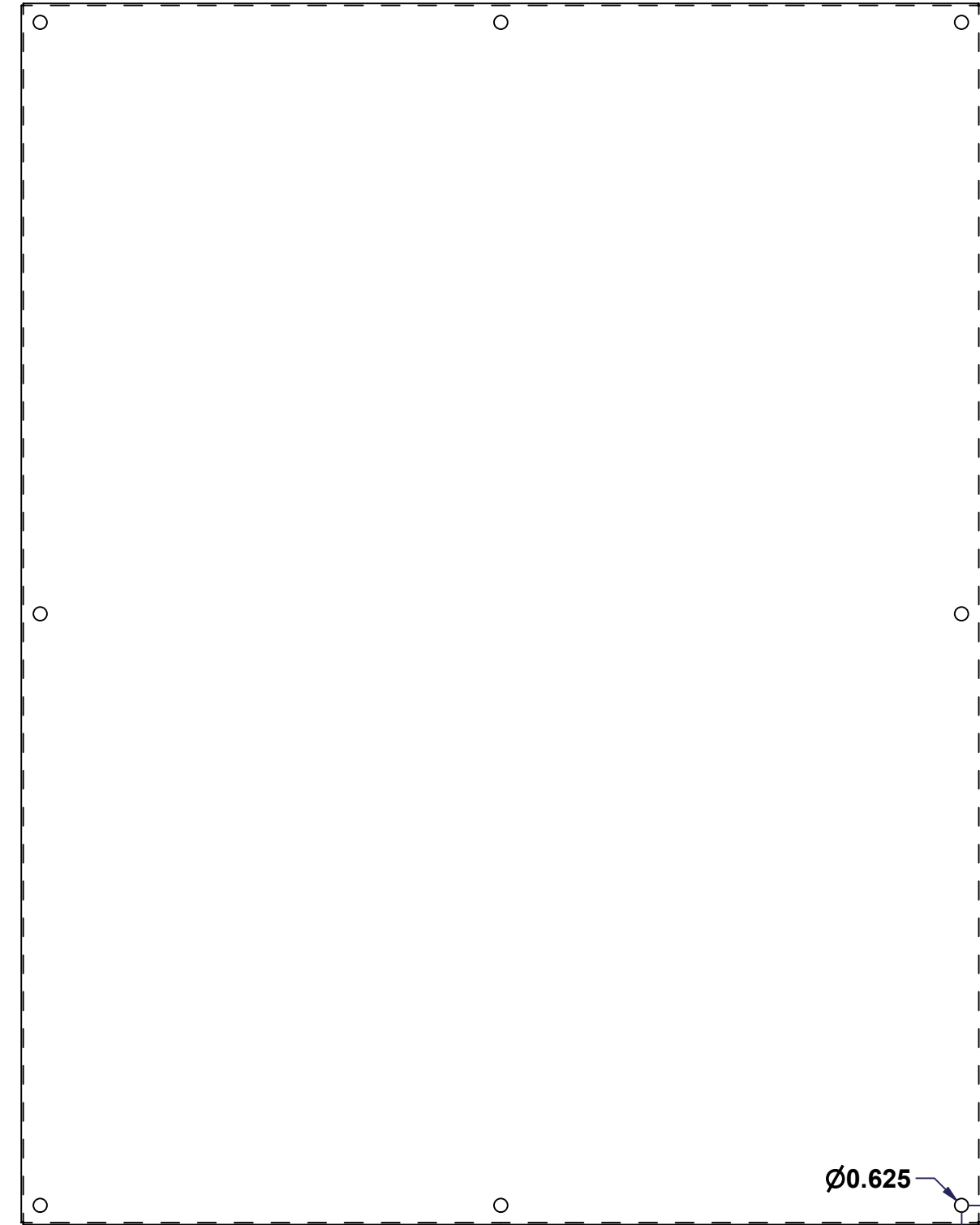

FRONT

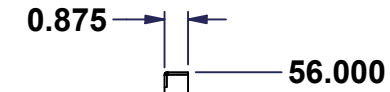

RIGHT

SEE BILL OF MATERIAL ON LAST PAGE

No.	Revisions	Date	By/Par

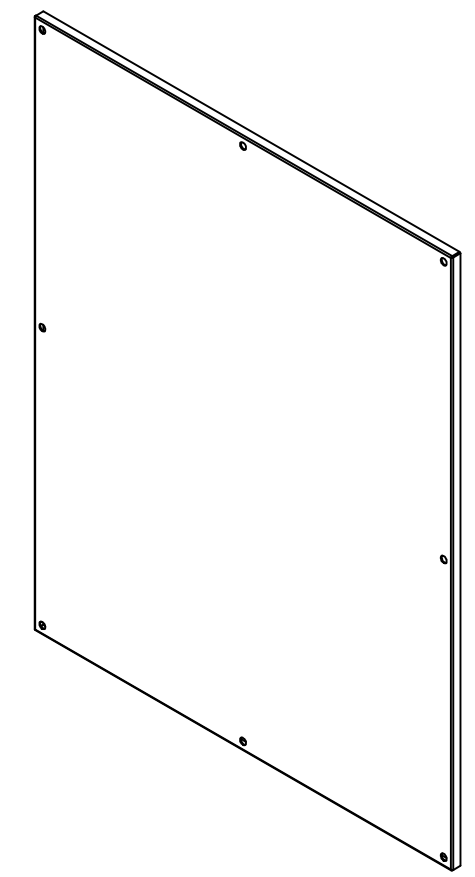

Isometric View



Tél: (450) 979-4373
 Fax: (450) 979-4626
 www.exmweb.com

Flatness
 Aplatissement
 Max 3.0mm
 Projection

Customer Client	Date
Drawn By Dessiné Par BoxCad	Date 04/11/2009
Material Matière	12 Ga Galvanized (2.5mm)

Color Couleur	Unpainted	Finish Fini	Unpainted
------------------	-----------	----------------	-----------

Description	Detail Rev.
885 SP6048G Inner Panel	

Part Number Numéro Pièce	Rev.	1
885SP6048G	0	2

This drawing is confidential and must not be reproduced or used without the consent of EXM

Ce dessin est confidentiel et ne doit pas être reproduit ou utilisé sans le consentement de EXM

No.	Revisions	Date	By/Par

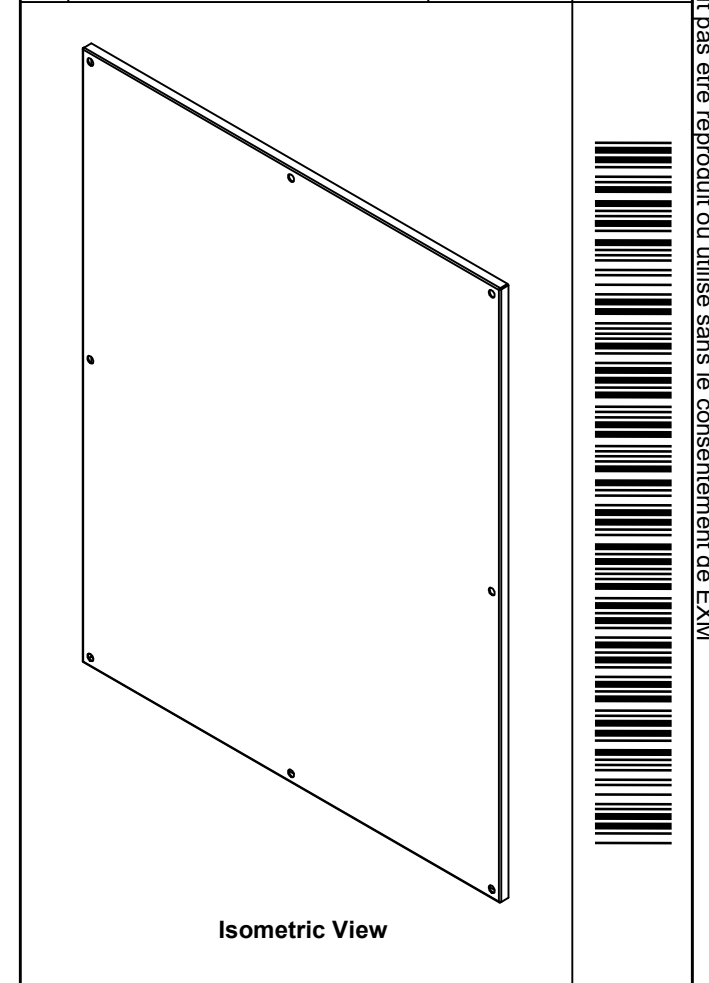

Isometric View

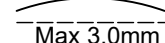
 Tél: (450) 979-4373 Fax: (450) 979-4626 www.exmweb.com		Flatness Aplatissement  Max 3.0mm
Customer Client		Date
Drawn By / Dessiné Par: BoxCad		Date: 04/11/2009
Material / Matière: 12 Ga Galvanized (2.5mm)		
Color / Couleur: Unpainted	Finish / Fini: Unpainted	
Description: 885 SP6048G Inner Panel		Detail Rev.
Part Number / Numéro Pièce: 885SP6048G		Rev. 0 / 2

Qty	Part Number	Rev	Description
1	885SP6048G-P	0	885 SP6048G Inner Panel Part
Parts List			