

This drawing is confidential and must not be reproduced or used without the consent of EXM

Ce dessin est confidentiel et ne doit pas être reproduit ou utilisé sans le consentement de EXM

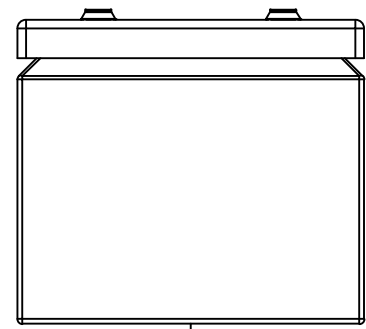

TOP

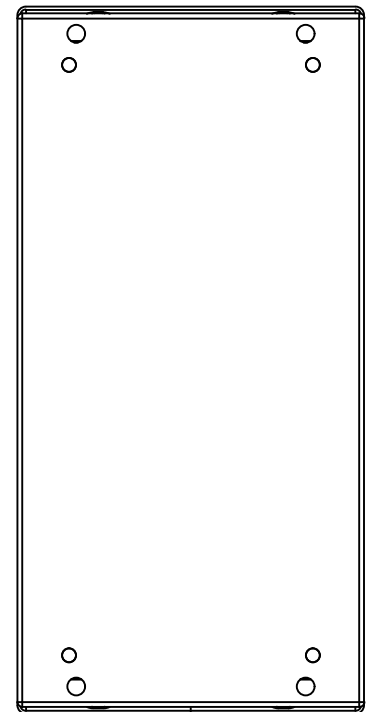

BACK

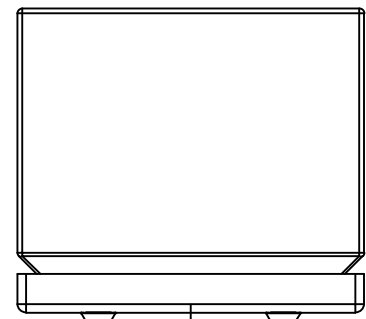

BOTTOM

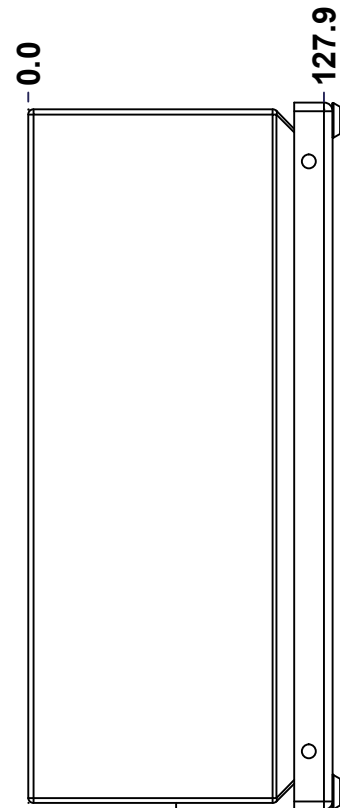

LEFT

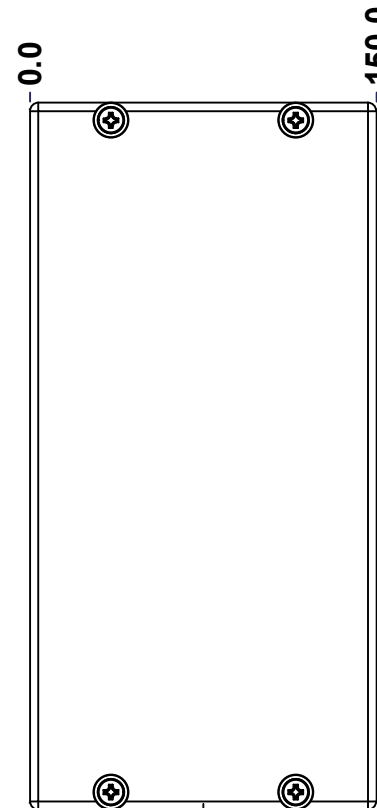

FRONT

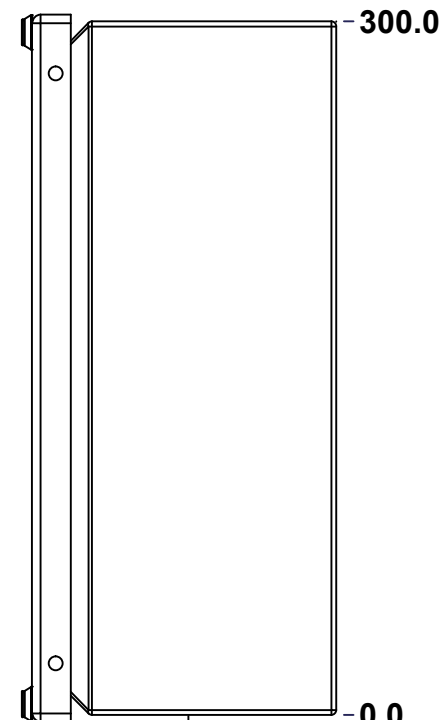

RIGHT

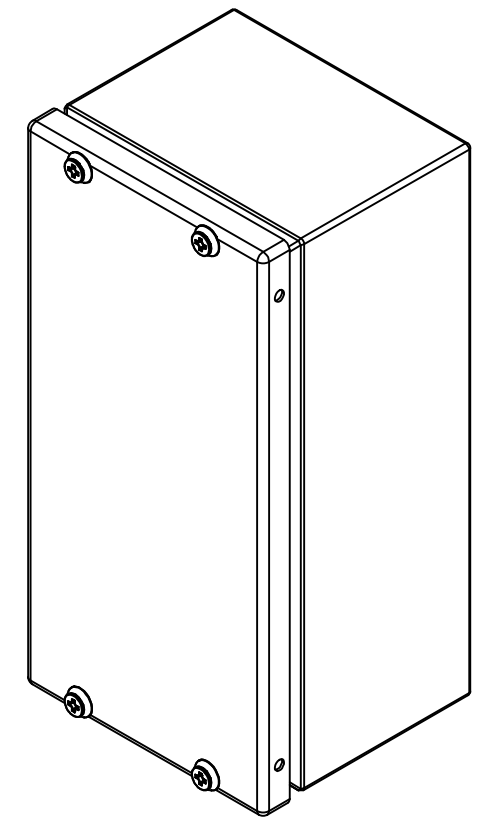

Isometric View

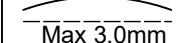
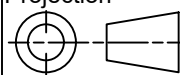

No.	Revisions	Date	By/Par
1	Updated	15-Apr-16	Admin
2	6412 ESTB301512	15-Apr-16	admin

 Tél: (450) 979-4373 Fax: (450) 979-4626 www.exmweb.com		Flatness Aplatissement  Max 3.0mm Projection 
Customer Client	Date	
Drawn By Dessiné Par	BoxCad: BoxCad	Date 13-Jan-14
Material Matière	16 Ga Cold Rolled A1008 CS Type B (1.4mm)	
Color Couleur	Light Grey RAL7035	Finish Fini Textured
Description	Detail Rev.	
6412ESTB 300mm x 150mm x 127.9mm Assembly		
Part Number Numéro Pièce	Rev.	1
6412ESTB301512	2	10

SEE BILL OF MATERIAL ON LAST PAGE

This drawing is confidential and must not be reproduced or used without the consent of EXM

Ce dessin est confidentiel et ne doit pas être reproduit ou utilisé sans le consentement de EXM

NOTE	
ITEM	DESCRIPTION
1	NEMA 4, 12 Enclosure (IP66)
2	C/W Standard ground standoffs on box and cover
3	W/O Standard door stiffener
4	W/O Inner panel
5	C/W Standard inner panel mounting standoffs

No.	Revisions	Date	By/Par
1	Updated	15-Apr-16	Admin
2	6412 ESTB301512	15-Apr-16	admin

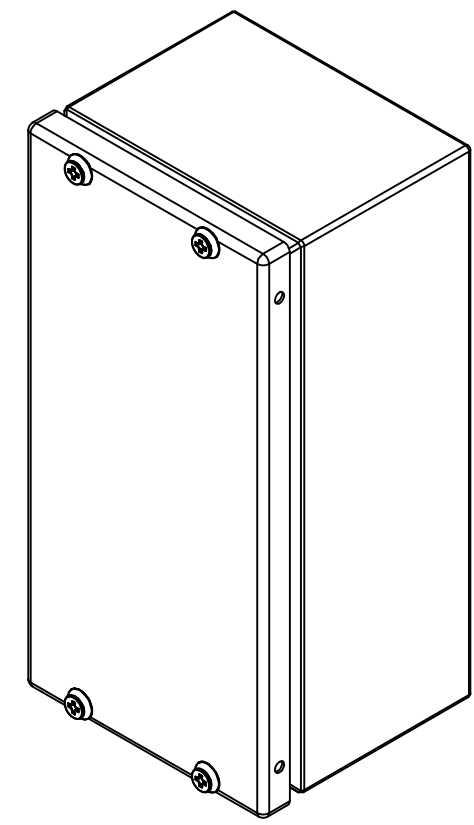

Isometric View

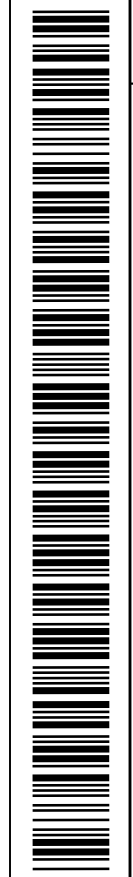

Tél: (450) 979-4373
 Fax: (450) 979-4626
www.exmweb.com

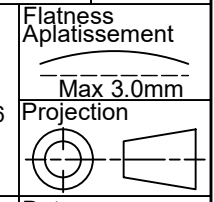

Customer Client	Date
Drawn By / Dessiné Par: BoxCad: BoxCad	Date: 13-Jan-14
Material / Matière: 16 Ga Cold Rolled A1008 CS Type B (1.4mm)	

Color / Couleur: Light Grey RAL7035	Finish / Fini: Textured
Description: 6412ESTB 300mm x 150mm x 127.9mm Assembly	Detail Rev.
Part Number / Numéro Pièce: 6412ESTB301512	Rev. 2

PACKING		
ITEM	QTY	DESCRIPTION
Cardboard sleeve	2	Top and Bottom
Cardboard strip	2	Between back of enclosure and inner panel
Plastic bag	1	To protect cover surface and inside gasket
Packaging label	1	White label with product number

Qty	Part Number	Rev	Description
1	6412ESTB301512C	2	6412ESTB 300mm x 150mm Cover
1	STK-K-02920	3	5412 ESSC Accessory Kit
2	6412ESTB301512BR-P	2	6412ESTB 300mm Bracket Part
8	STK-Q-07210	0	Flange Lock Nut M6
1	6412ESTB301512B	2	6412ESTB 300mm x 150mm x 127.9mm Body

Parts List

This drawing is confidential and must not be reproduced or used without the consent of EXM

Ce dessin est confidentiel et ne doit pas être reproduit ou utilisé sans le consentement de EXM

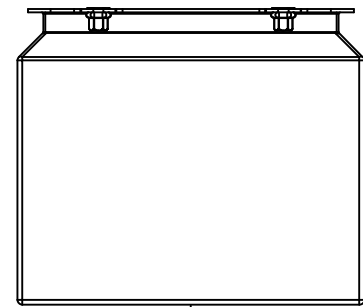

TOP

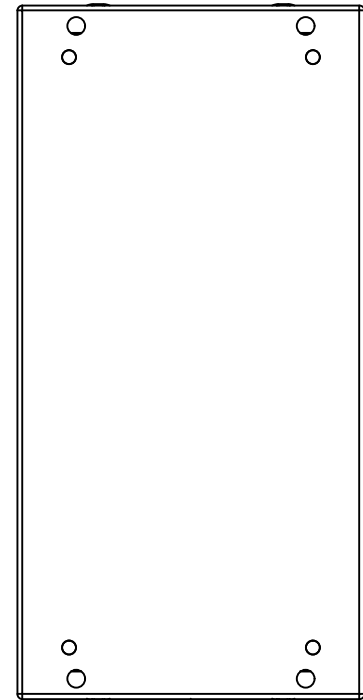

BACK

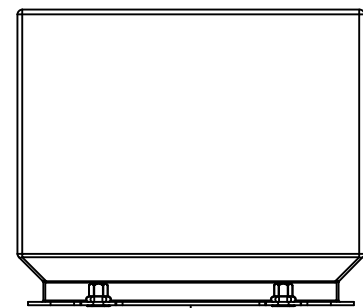

BOTTOM

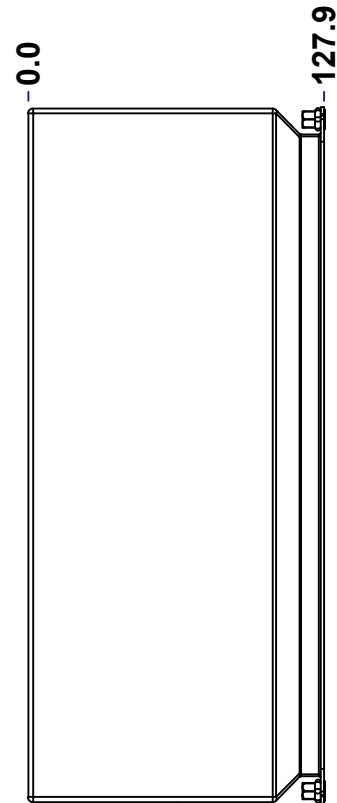

LEFT

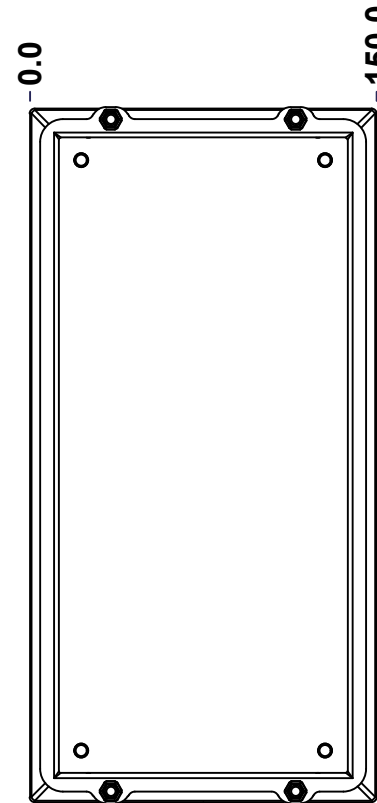

FRONT

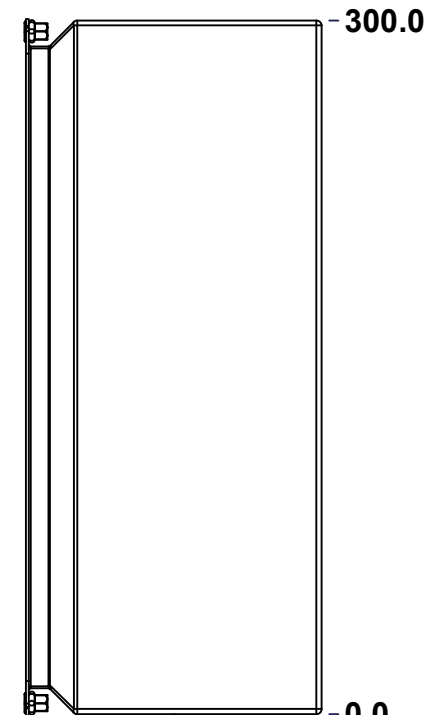

RIGHT

No.	Revisions	Date	By/Par
1	Updated	15-Apr-16	Admin
2	6412 ESTB301512	15-Apr-16	admin

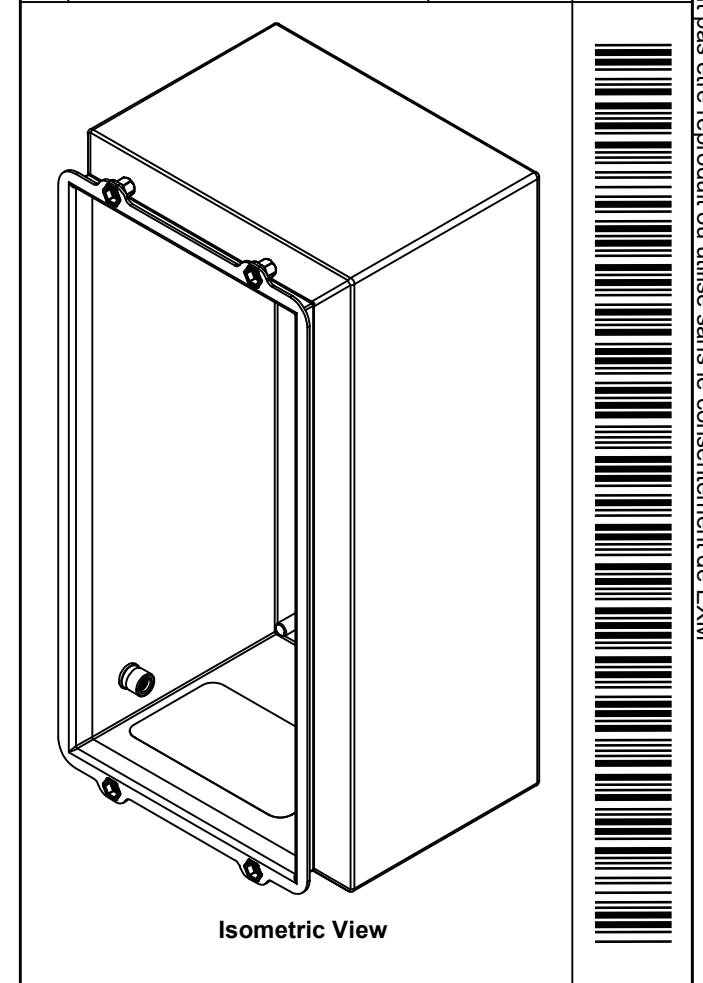

Isometric View

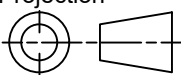

 Tél: (450) 979-4373 Fax: (450) 979-4626 www.exmweb.com		Flatness Aplatissement Max 3.0mm Projection 
Customer Client	Date	
Drawn By Dessiné Par	BoxCad: BoxCad	Date 13-Jan-14
Material Matière	16 Ga Cold Rolled A1008 CS Type B (1.4mm)	
Color Couleur	Light Grey RAL7035	Finish Fini Textured
Description	Detail Rev.	
6412ESTB 300mm x 150mm x 127.9mm Body		
Part Number Numéro Pièce	Rev.	3
6412ESTB301512B	2	10

SEE BILL OF MATERIAL ON LAST PAGE

This drawing is confidential and must not be reproduced or used without the consent of EXM

Ce dessin est confidentiel et ne doit pas être reproduit ou utilisé sans le consentement de EXM

STANDARD FEATURES ARE NOT LISTED IN THIS HOLE TABLE			
HOLE TABLE - BOTTOM VIEW (CUSTOM FEATURE ONLY)			
CUT-OUT	XDIM	YDIM	DESCRIPTION
1	50.8	67.6	LABEL_EXM

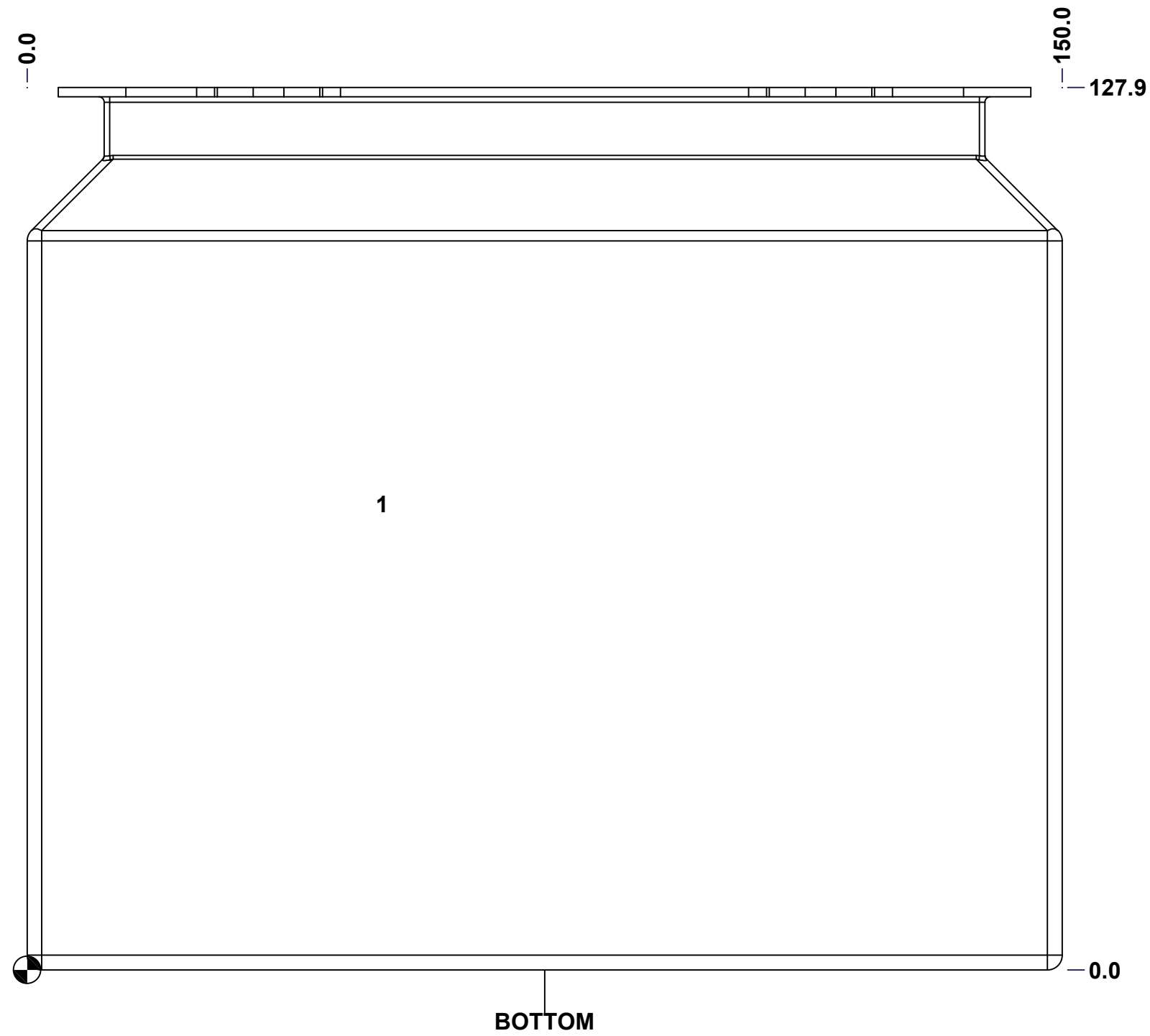

	Description 6412ESTB 300mm x 150mm x 120mm Body		Status (NULL)
	Part Number Numéro Pièce 6412ESTB301512B		Rev. 4 2 / 10

This drawing is confidential and must not be reproduced or used without the consent of EXM

Ce dessin est confidentiel et ne doit pas être reproduit ou utilisé sans le consentement de EXM

STANDARD FEATURES ARE NOT LISTED IN THIS HOLE TABLE			
HOLE TABLE - LEFT VIEW (CUSTOM FEATURE ONLY)			
CUT-OUT	XDIM	YDIM	DESCRIPTION
1	85.1	22.2	STANDOFF M6 x 10mm (Inside)

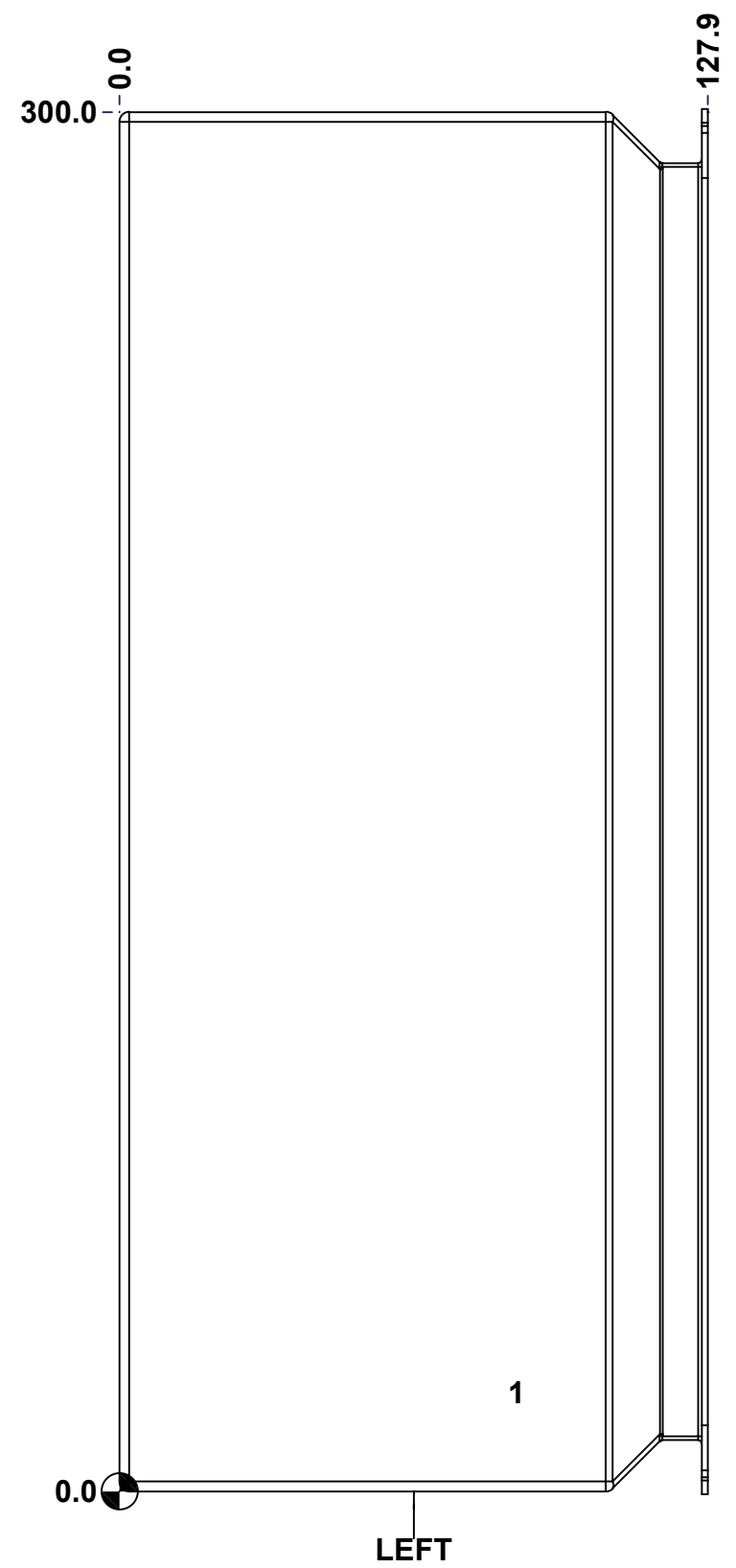

	Description 6412ESTB 300mm x 150mm x 120mm Body		Status (NULL)
	Part Number Numéro Pièce 6412ESTB301512B		Rev. 5 2 / 10

This drawing is confidential and must not be reproduced or used without the consent of EXM

Ce dessin est confidentiel et ne doit pas être reproduit ou utilisé sans le consentement de EXM

STANDARD FEATURES ARE NOT LISTED IN THIS HOLE TABLE

HOLE TABLE - BACK VIEW (CUSTOM FEATURE ONLY)

CUT-OUT	XDIM	YDIM	DESCRIPTION
1	22.2	277.8	PEM FH-M6-20ZI (Inside)
2	127.8	277.8	PEM FH-M6-20ZI (Inside)
3	127.8	22.2	PEM FH-M6-20ZI (Inside)
4	22.2	22.2	PEM FH-M6-20ZI (Inside)

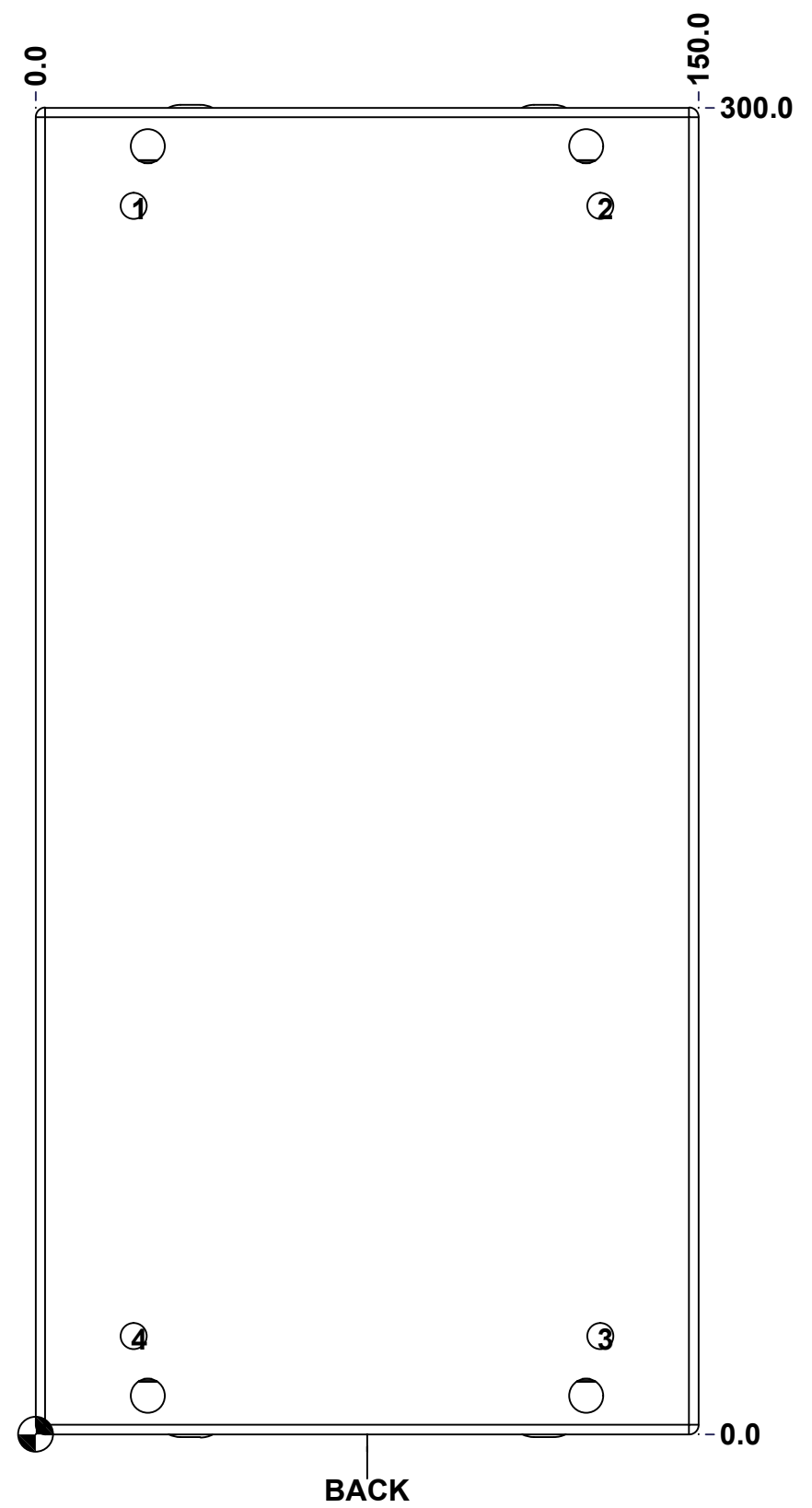

	Description 6412ESTB 300mm x 150mm x 120mm Body		Status (NULL)
	Part Number Numéro Pièce 6412ESTB301512B		Rev. 2 6 10

This drawing is confidential and must not be reproduced or used without the consent of EXM

Ce dessin est confidentiel et ne doit pas être reproduit ou utilisé sans le consentement de EXM

No.	Revisions	Date	By/Par
1	Updated	15-Apr-16	Admin
2	6412 ESTB301512	15-Apr-16	admin

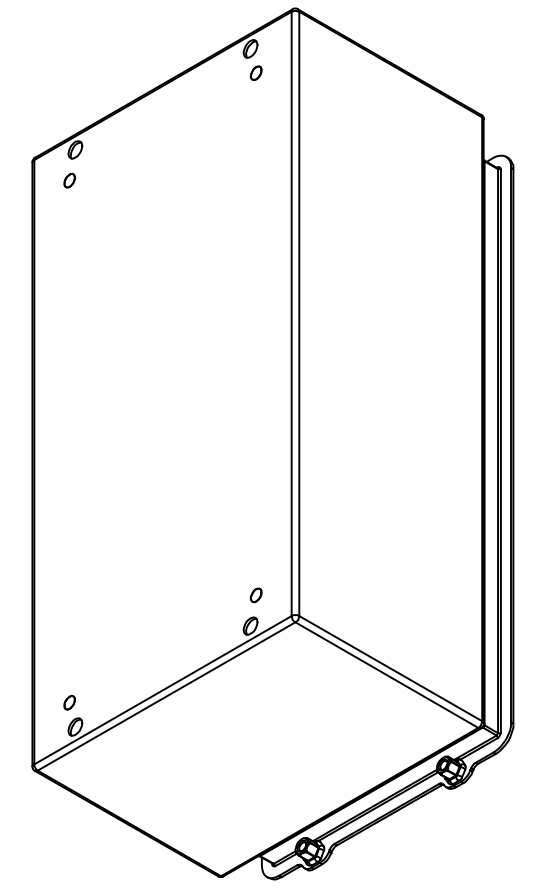

Isometric View

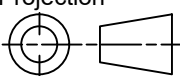

 Tél: (450) 979-4373 Fax: (450) 979-4626 www.exmweb.com	Flatness Aplatissement	Max 3.0mm
	Projection	
Customer Client	Date	
Drawn By Dessiné Par	BoxCad: BoxCad	Date 13-Jan-14
Material Matière	16 Ga Cold Rolled A1008 CS Type B (1.4mm)	
Color Couleur	Light Grey RAL7035	Finish Fini Textured
Description	6412ESTB 300mm x 150mm x 127.9mm Body	Detail Rev.
Part Number Numéro Pièce	6412ESTB301512B	Rev. 2

Qty	Part Number	Rev	Description
4	STK-PEM-FH-M6-20ZI	0	PEM Self-Clinching Stud M6 x 20.0mm
1	STK-S-00100	0	3.5" x 2" Silver Milar Flexcon Sticker
1	STK-P-03820R	0	Powder Paint (Light Grey / Rough Textured)
1	6412ESTB301512B-P	2	6412ESTB 300mm x 150mm x 120mm Body Part
1	STK-Q-08350	5	Standoff M6 x 10mm
4	RIVET_NUT_M5_FH_OE	0	Rivet Nut M5 (Low Profile Open End)
Parts List			

This drawing is confidential and must not be reproduced or used without the consent of EXM

Ce dessin est confidentiel et ne doit pas être reproduit ou utilisé sans le consentement de EXM

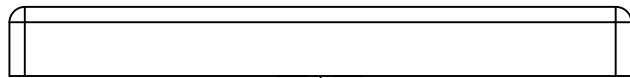

TOP

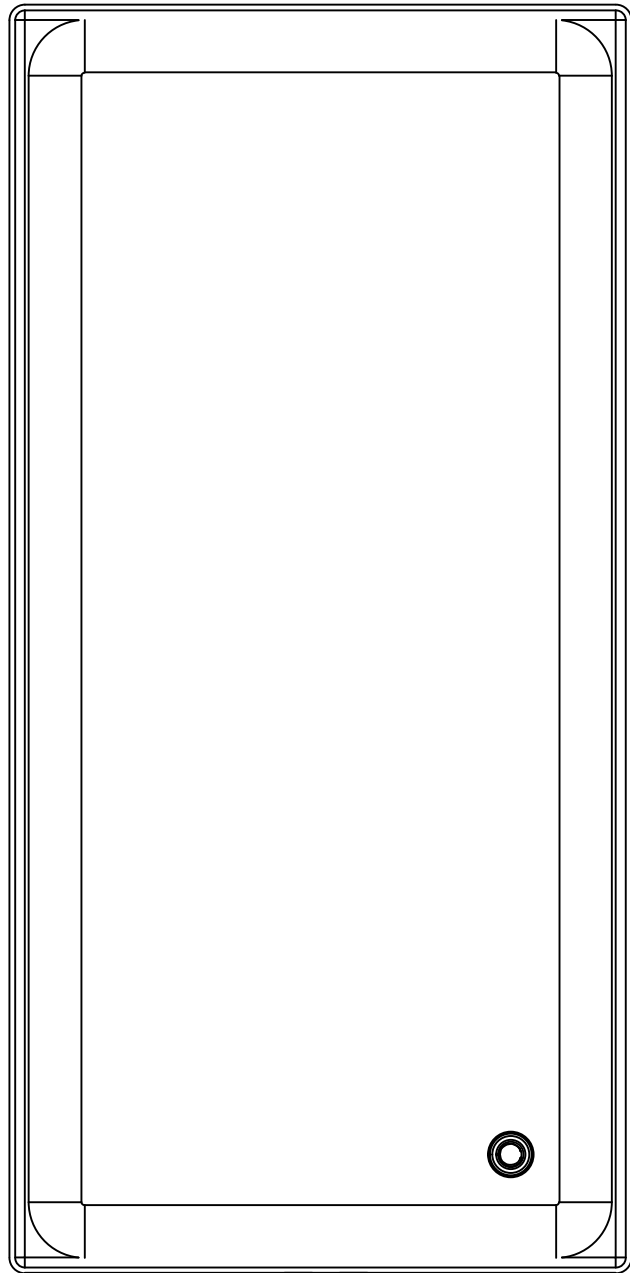

BACK

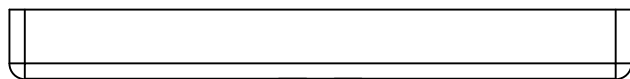

BOTTOM

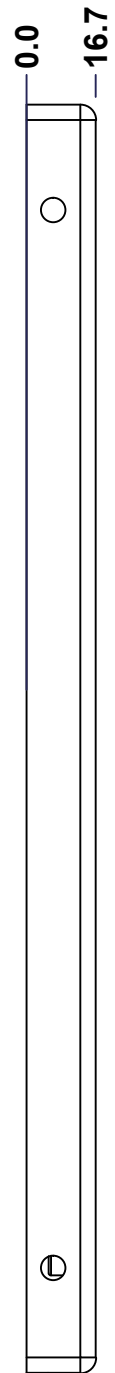

LEFT

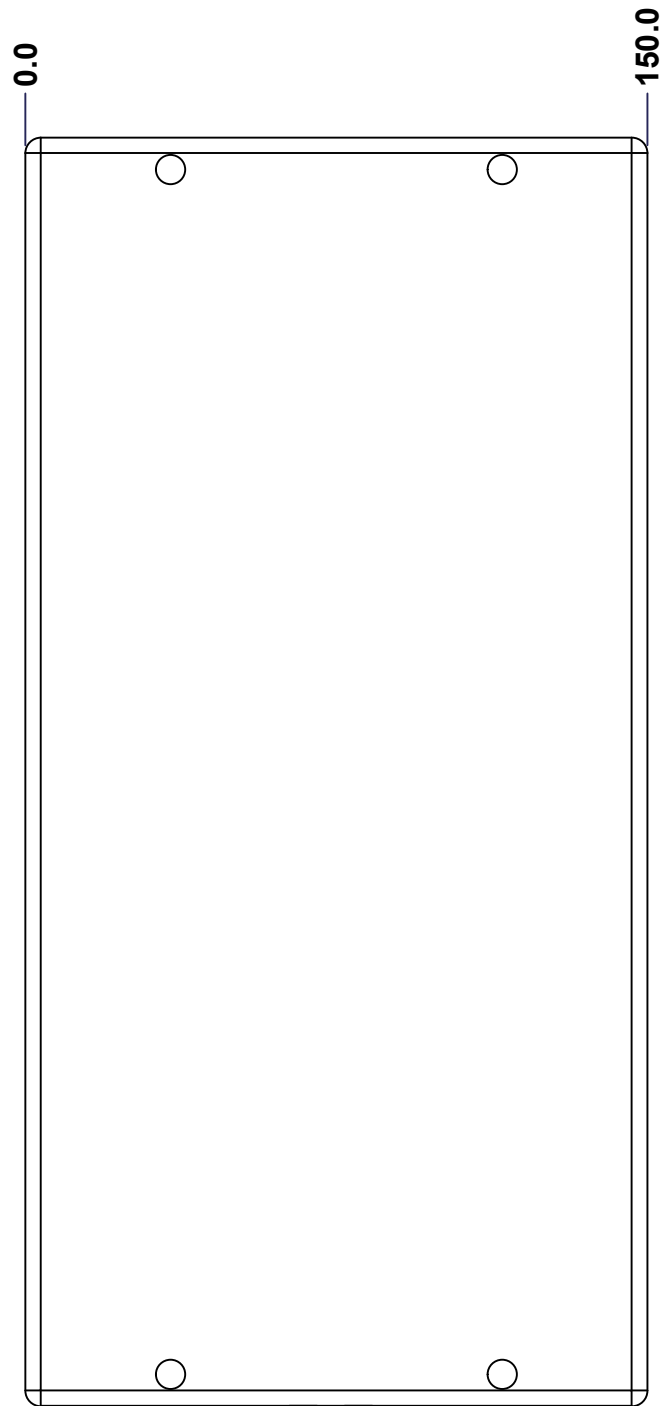

FRONT

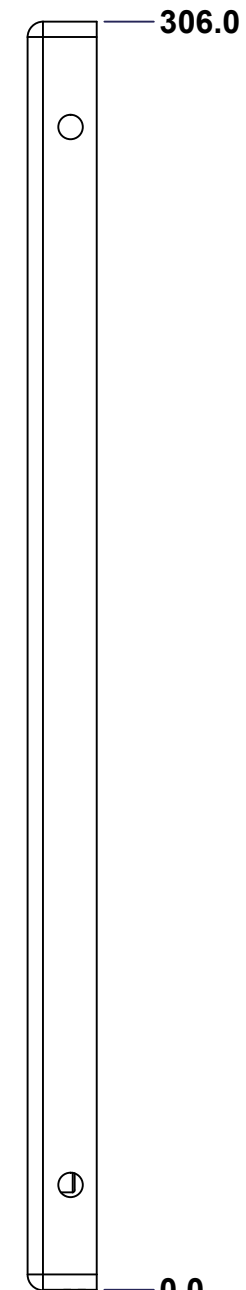

RIGHT

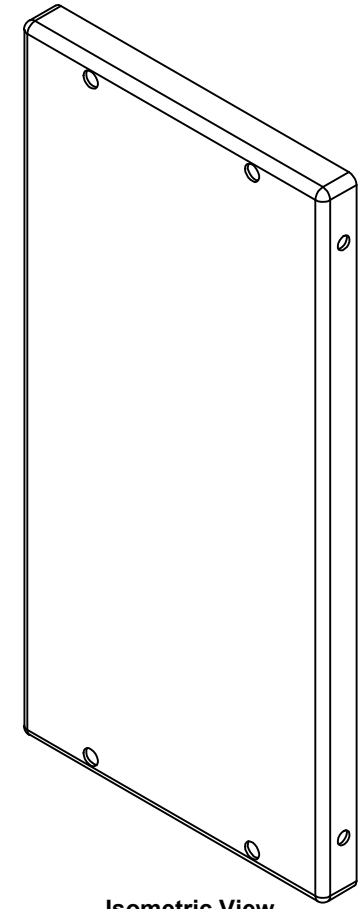

Isometric View

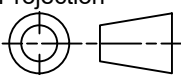

No.	Revisions	Date	By/Par
1	Updated	15-Apr-16	Admin
2	6412 ESTB301512	15-Apr-16	admin

 Tél: (450) 979-4373 Fax: (450) 979-4626 www.exmweb.com		Flatness Aplatissement Max 3.0mm Projection 
Customer Client	Date	
Drawn By Dessiné Par	BoxCad: BoxCad	Date 13-Jan-14
Material Matière	16 Ga Cold Rolled A1008 CS Type B (1.4mm)	
Color Couleur	Light Grey RAL7035	Finish Fini Textured
Description		Detail Rev.
6412ESTB 300mm x 150mm Cover		
Part Number Numéro Pièce	Rev.	8
6412ESTB301512C	2	10

SEE BILL OF MATERIAL ON LAST PAGE

This drawing is confidential and must not be reproduced or used without the consent of EXM

Ce dessin est confidentiel et ne doit pas être reproduit ou utilisé sans le consentement de EXM

STANDARD FEATURES ARE NOT LISTED IN THIS HOLE TABLE

HOLE TABLE - FRONT VIEW (CUSTOM FEATURE ONLY)

CUT-OUT	XDIM	YDIM	DESCRIPTION
1	29.1	28.6	STANDOFF M6 x 10mm (Inside)

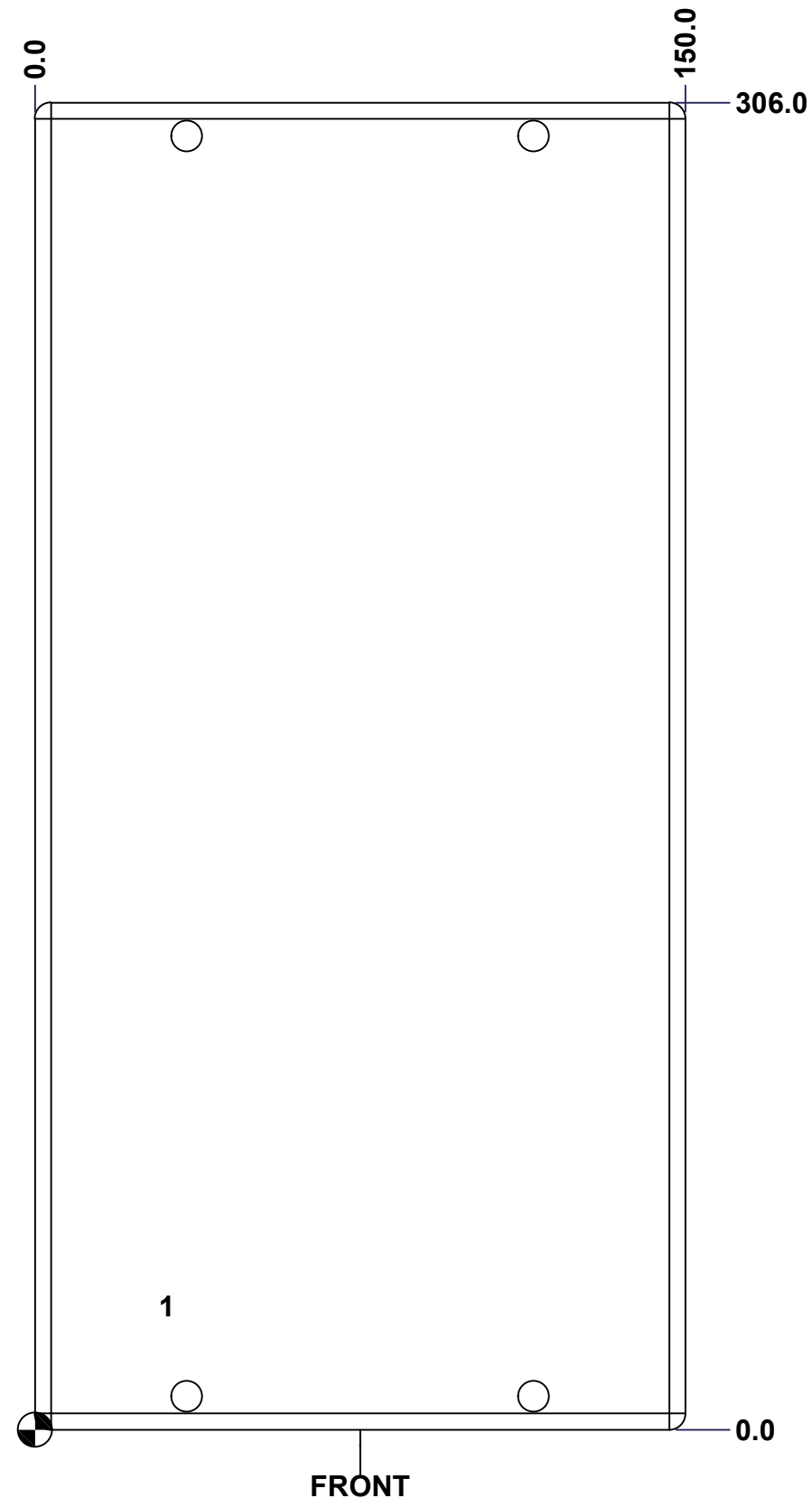

	Description	Status
	6412ESTB 300mm x 150mm Cover	(NULL)
Part Number Numéro Pièce 6412ESTB301512C	Rev.	9
	2	10

This drawing is confidential and must not be reproduced or used without the consent of EXM

Ce dessin est confidentiel et ne doit pas être reproduit ou utilisé sans le consentement de EXM

No.	Revisions	Date	By/Par
1	Updated	15-Apr-16	Admin
2	6412 ESTB301512	15-Apr-16	admin

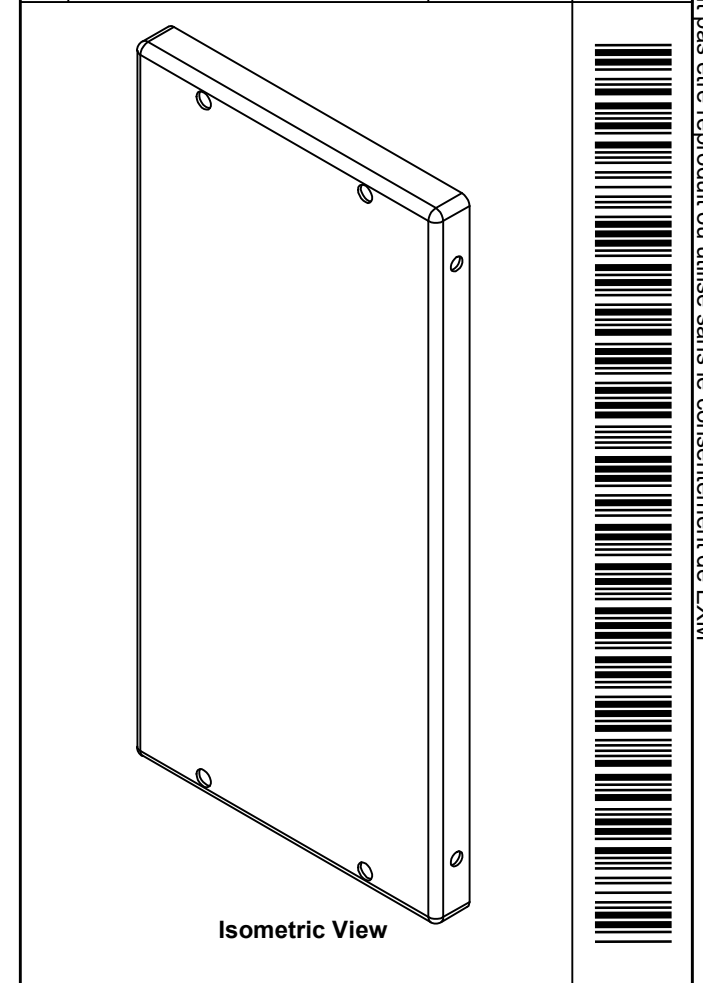

EXM
www.exmweb.com

Tél: (450) 979-4373
Fax: (450) 979-4626

Flatness
Aplatissement
Max 3.0mm

Projection

Customer Client	Date
Drawn By / Dessiné Par: BoxCad: BoxCad	Date: 13-Jan-14
Material / Matière: 16 Ga Cold Rolled A1008 CS Type B (1.4mm)	
Color / Couleur: Light Grey RAL7035	Finish / Fini: Textured

Qty	Part Number	Rev	Description
1	STK-Q-08350	5	Standoff M6 x 10mm
1	STK-P-03820R	0	Powder Paint (Light Grey / Rough Textured)
1	6412ESTB301512G	2	6412ESTB 300mm x 150mm Gasket
1	6412ESTB301512C-P	2	6412ESTB 300mm x 150mm Cover Part
Parts List			

Description: 6412ESTB 300mm x 150mm Cover	Detail Rev.
Part Number / Numéro Pièce: 6412ESTB301512C	Rev. 2
	10 / 10