

This drawing is confidential and must not be reproduced or used without the consent of EXM

Ce dessin est confidentiel et ne doit pas être reproduit ou utilisé sans le consentement de EXM

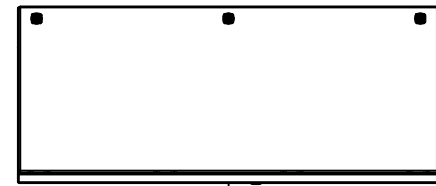

TOP

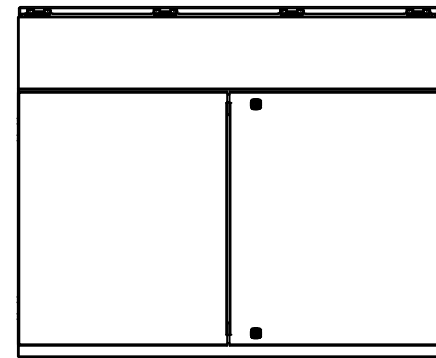

BACK

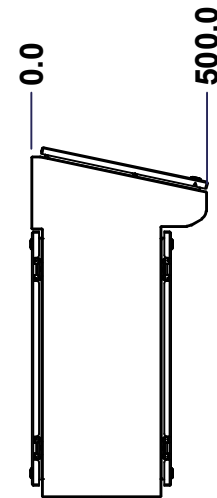

LEFT

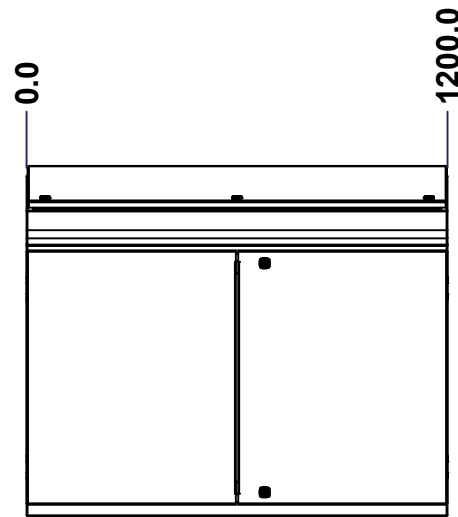

FRONT

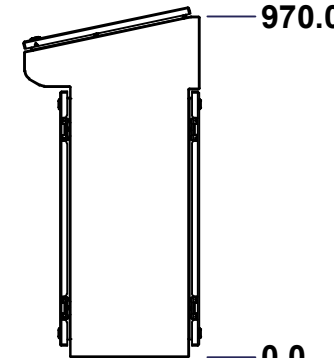

RIGHT

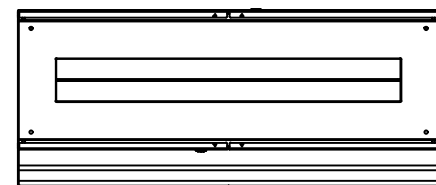

BOTTOM

No.	Revisions	Date	By/Par

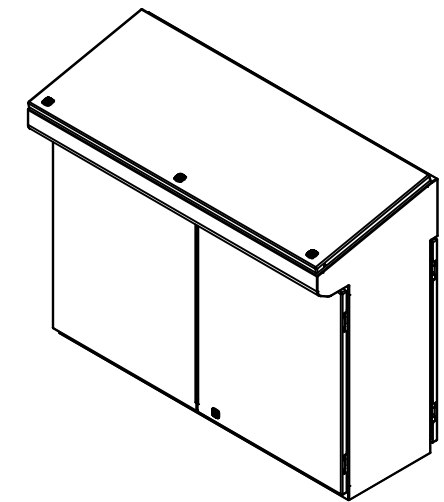

Isometric View



Tél: (450) 979-4373
 Fax: (450) 979-4626
www.exmweb.com

Flatness
Aplatissement

Max 3.0mm

Projection

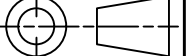

Customer Client _____ Date _____

Drawn By Dessiné Par BoxCad: BoxCad Date 06-Nov-14

Material Matière 14 Ga Cold Rolled A1008 CS Type B (1.7mm)

Color Couleur Light Grey RAL7035 Finish Fini Textured

Description 6500Codd 1000mm x 1200mm x 400mm Assembly
 Detail Rev. _____

Part Number Numéro Pièce **6500Codd1204** Rev. **0** 1/23

SEE BILL OF MATERIAL ON LAST PAGE

This drawing is confidential and must not be reproduced or used without the consent of EXM

Ce dessin est confidentiel et ne doit pas être reproduit ou utilisé sans le consentement de EXM

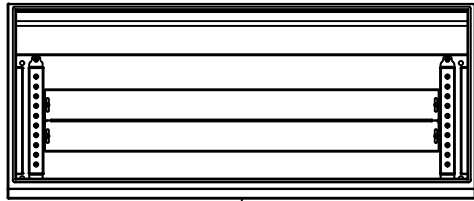

TOP

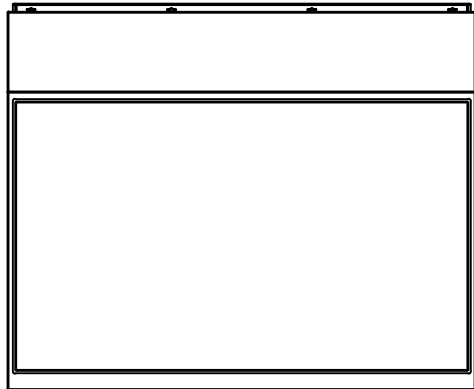

BACK

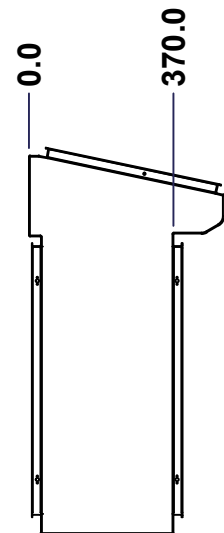

LEFT

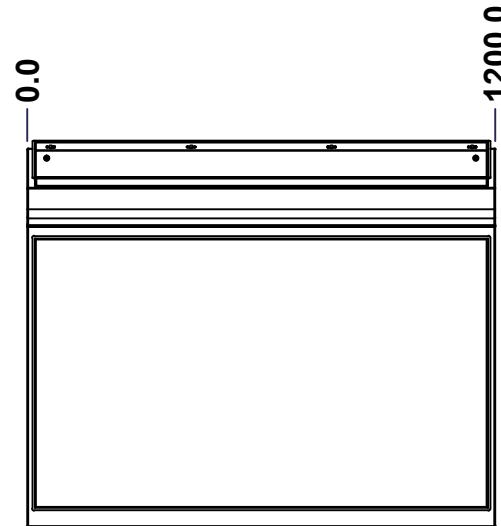

FRONT

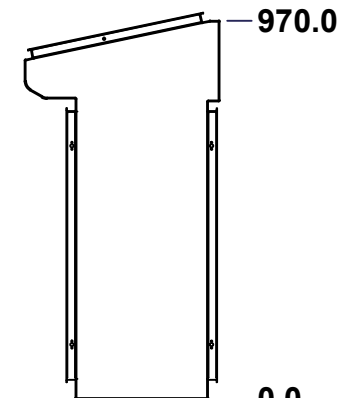

RIGHT

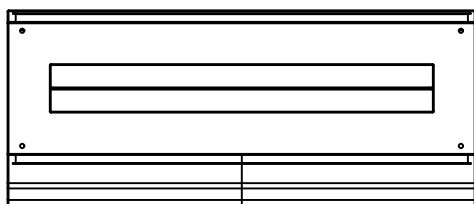

BOTTOM

No.	Revisions	Date	By/Par

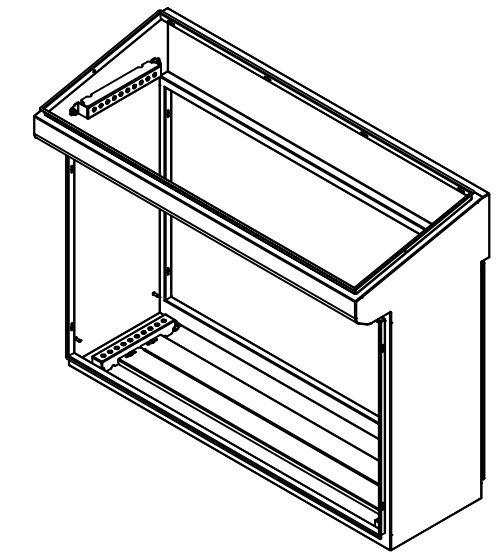

Isometric View



Tél: (450) 979-4373
 Fax: (450) 979-4626
www.exmweb.com

Flatness
Aplatissement

Max 3.0mm

Projection



Customer Client	Date
Drawn By Dessiné Par BoxCad: BoxCad	Date 06-Nov-14
Material Matière 14 Ga Cold Rolled A1008 CS Type B (1.7mm)	

Color Couleur Light Grey RAL7035	Finish Fini Textured
-------------------------------------	-------------------------

Description 6500Codd 1000mm x 1200mm x 400mm Body	Detail Rev.
--	-------------

Part Number Numéro Pièce	Rev.	3
6500Codd1204B	0	23

SEE BILL OF MATERIAL ON LAST PAGE

This drawing is confidential and must not be reproduced or used without the consent of EXM

Ce dessin est confidentiel et ne doit pas être reproduit ou utilisé sans le consentement de EXM

STANDARD FEATURES ARE NOT LISTED IN THIS HOLE TABLE

HOLE TABLE - RIGHT VIEW (CUSTOM FEATURE ONLY)

CUT-OUT	XDIM	YDIM	DESCRIPTION
1	42.5	815.4	STUD M6 x 18mm (Inside)
2	357.5	815.4	STUD M6 x 18mm (Inside)

3	55.0	75.0	GND STUD M6 x 16mm (Inside)
4	345.0	75.0	GND STUD M6 x 16mm (Inside)

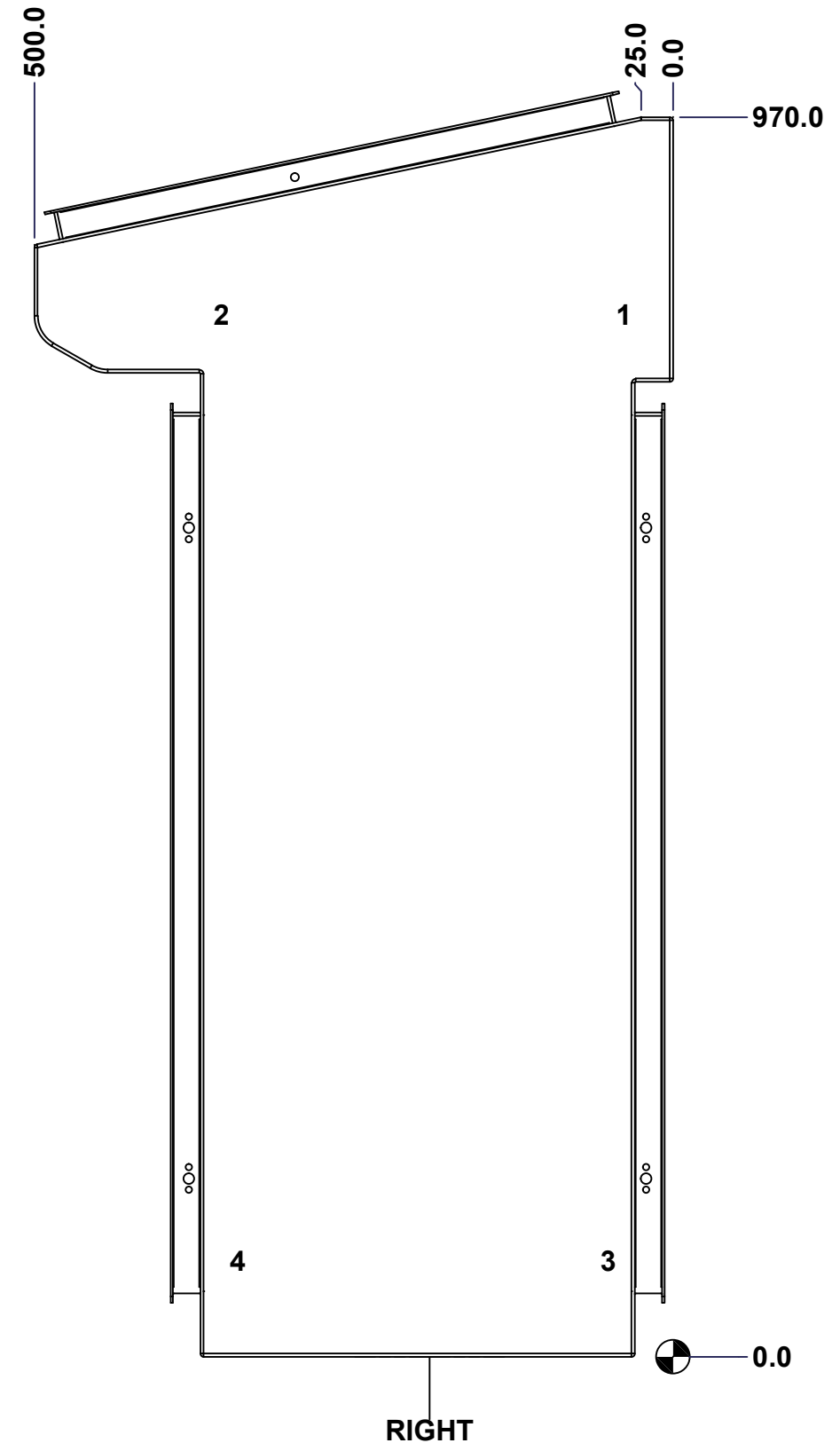

	Description 6500Codd 1000mm x 1200mm x 400mm Body		Status (NULL)
	Part Number Numéro Pièce 6500Codd1204B		Rev. 4 0

This drawing is confidential and must not be reproduced or used without the consent of EXM

Ce dessin est confidentiel et ne doit pas être reproduit ou utilisé sans le consentement de EXM

STANDARD FEATURES ARE NOT LISTED IN THIS HOLE TABLE

HOLE TABLE - BOTTOM VIEW (CUSTOM FEATURE ONLY)

CUT-OUT	XDIM	YDIM	DESCRIPTION
1	72.5	12.5	RAIL STUD M6 x 18mm (Inside)
2	72.5	170.0	RAIL STUD M6 x 18mm (Inside)
3	1127.5	12.5	RAIL STUD M6 x 18mm (Inside)
4	1127.5	170.0	RAIL STUD M6 x 18mm (Inside)

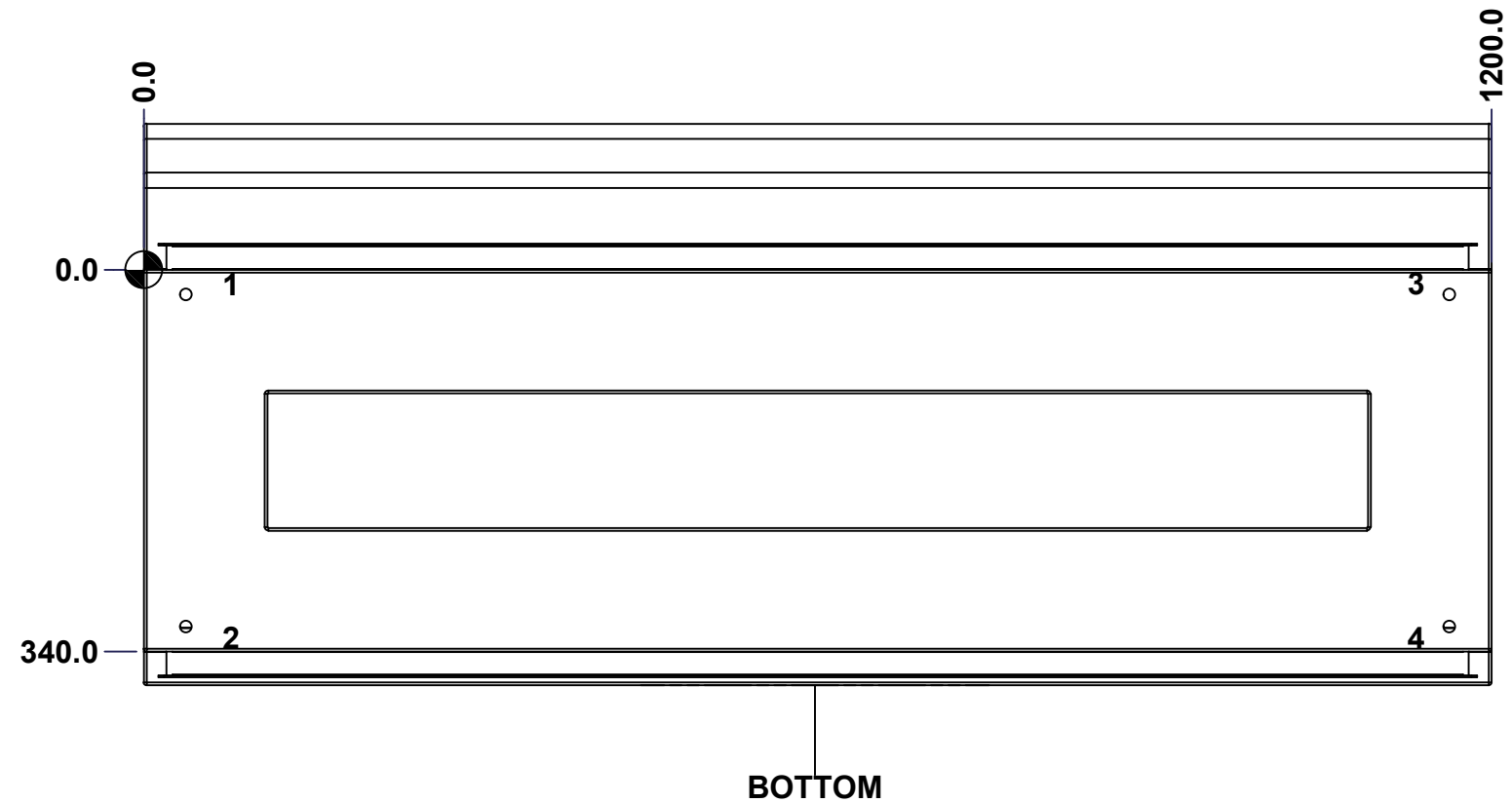

	Description 6500Codd 1000mm x 1200mm x 400mm Body	Status (NULL)
	Part Number Numéro Pièce 6500Codd1204B	Rev. 5 0

This drawing is confidential and must not be reproduced or used without the consent of EXM

Ce dessin est confidentiel et ne doit pas être reproduit ou utilisé sans le consentement de EXM

STANDARD FEATURES ARE NOT LISTED IN THIS HOLE TABLE

HOLE TABLE - LEFT VIEW (CUSTOM FEATURE ONLY)

CUT-OUT	XDIM	YDIM	DESCRIPTION
1	42.5	815.4	STUD M6 x 18mm (Inside)
2	357.5	815.4	STUD M6 x 18mm (Inside)

3	345.0	75.0	GND STUD M6 x 16mm (Inside)
4	55.0	75.0	GND STUD M6 x 16mm (Inside)

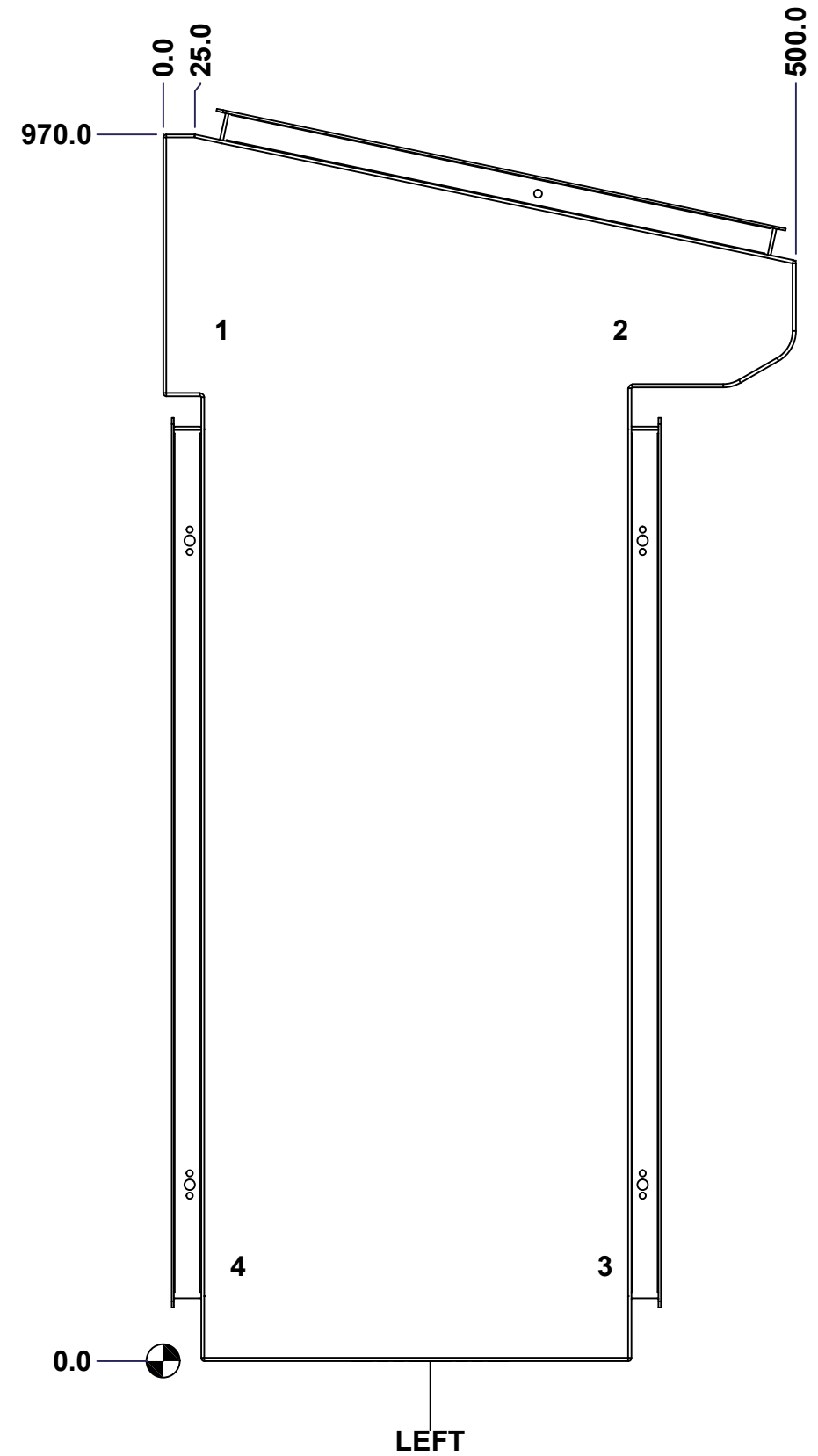

	Description 6500Codd 1000mm x 1200mm x 400mm Body	Status (NULL)
	Part Number Numéro Pièce 6500Codd1204B	Rev. 6 0

This drawing is confidential and must not be reproduced or used without the consent of EXM

Ce dessin est confidentiel et ne doit pas être reproduit ou utilisé sans le consentement de EXM

STANDARD FEATURES ARE NOT LISTED IN THIS HOLE TABLE			
HOLE TABLE - BACK VIEW (CUSTOM FEATURE ONLY)			
CUT-OUT	XDIM	YDIM	DESCRIPTION
1	50.0	945.0	GND STUD M6 x 16mm (Inside)
2	1150.0	945.0	GND STUD M6 x 16mm (Inside)

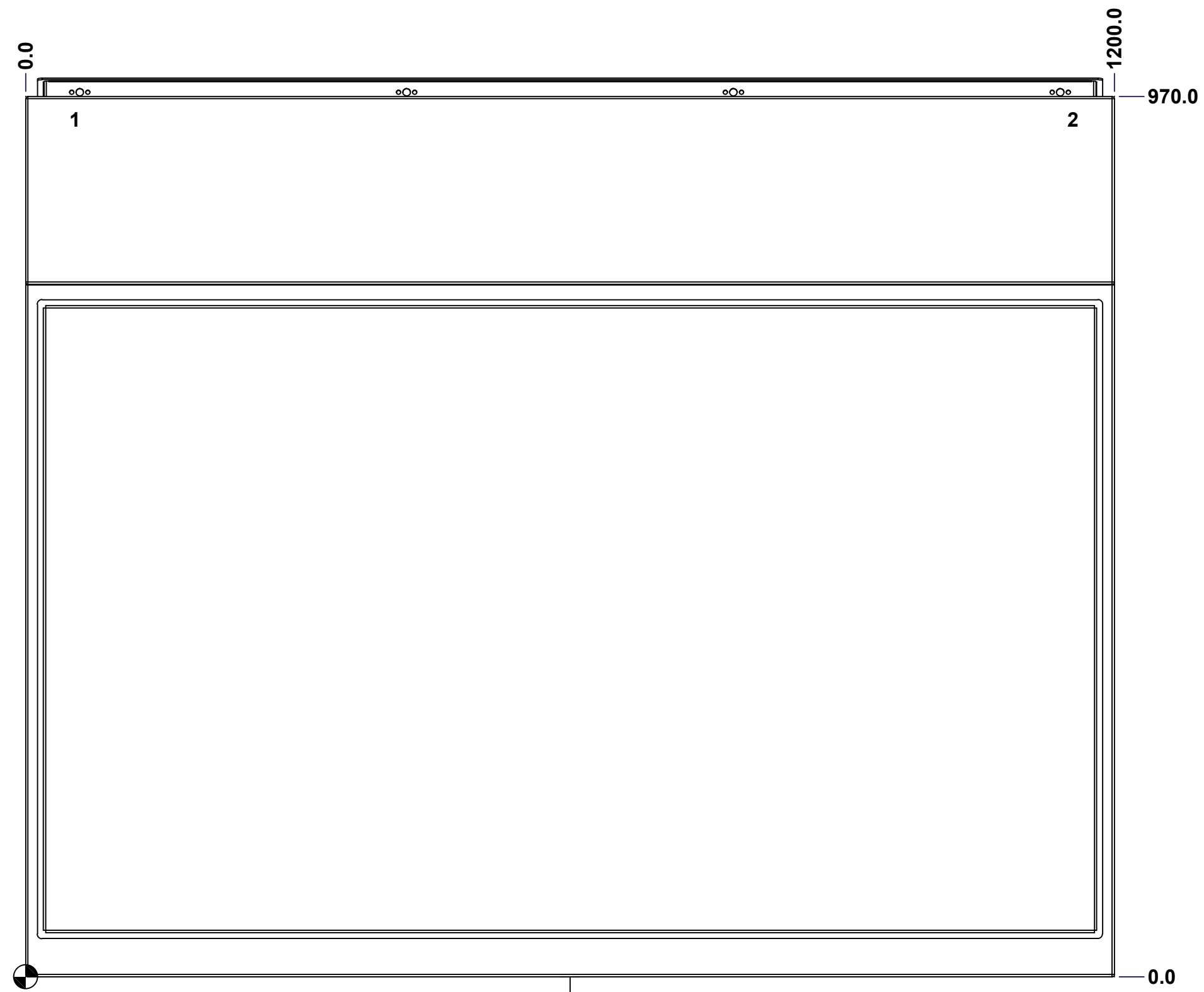

BACK

	Description 6500Codd 1000mm x 1200mm x 400mm Body		Status (NULL)
	Part Number Numéro Pièce 6500Codd1204B		Rev. 7 0

This drawing is confidential and must not be reproduced or used without the consent of EXM

Ce dessin est confidentiel et ne doit pas être reproduit ou utilisé sans le consentement de EXM

No.	Revisions	Date	By/Par

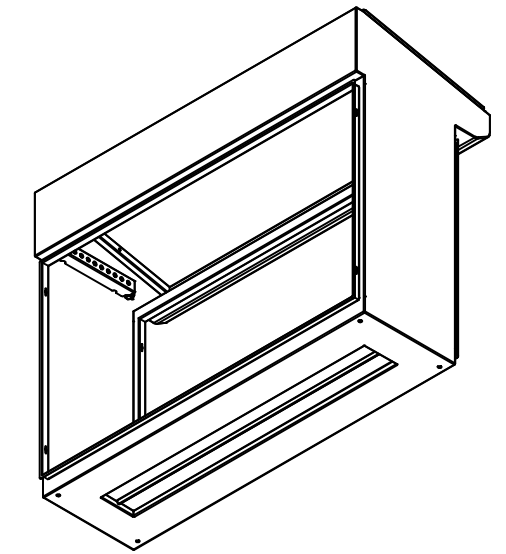

Isometric View

EXM
www.exmweb.com

Tél: (450) 979-4373
Fax: (450) 979-4626

Flatness
Aplatissement
Max 3.0mm

Projection

Customer Client
Date

Drawn By / Dessiné Par: BoxCad: BoxCad
Date: 06-Nov-14

Material / Matière: 14 Ga Cold Rolled A1008 CS Type B (1.7mm)

Color / Couleur: Light Grey RAL7035
Finish / Fini: Textured

Description: 6500Codd 1000mm x 1200mm x 400mm Body
Detail Rev.

Part Number / Numéro Pièce: **6500Codd1204B**
Rev. 0

Qty	Part Number	Rev	Description
1	STK-P-03820R	0	Powder Paint (Light Grey / Rough Textured)
4	STK-Q-49090-275	2	Mounting Rail 275.0mm
8	STK-Q-16031	0	M6 x 10mm Stud (No Paint Cap Required)
1	6500Codd1204GP	0	6500Codd 1000mm x 1200mm x 400mm Gland Plate
1	6500Codd1204B-P	0	6500Codd 1000mm x 1200mm x 400mm Body Part
8	STK-Q-07220	1	M6 Nylon Insert Lock Nut
6	STK-Q-16080	0	Ground Stud M6 x 16mm Steel
Parts List			

This drawing is confidential and must not be reproduced or used without the consent of EXM

Ce dessin est confidentiel et ne doit pas être reproduit ou utilisé sans le consentement de EXM

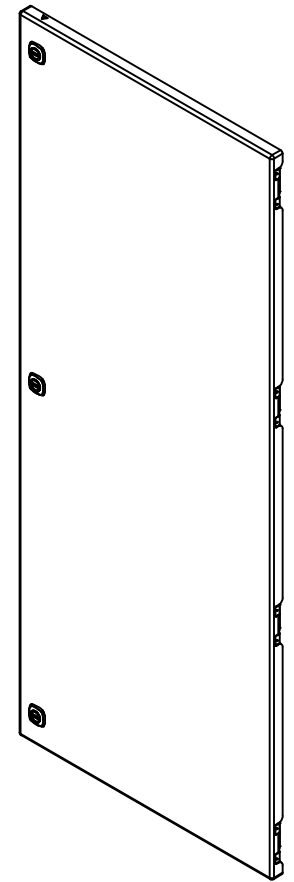
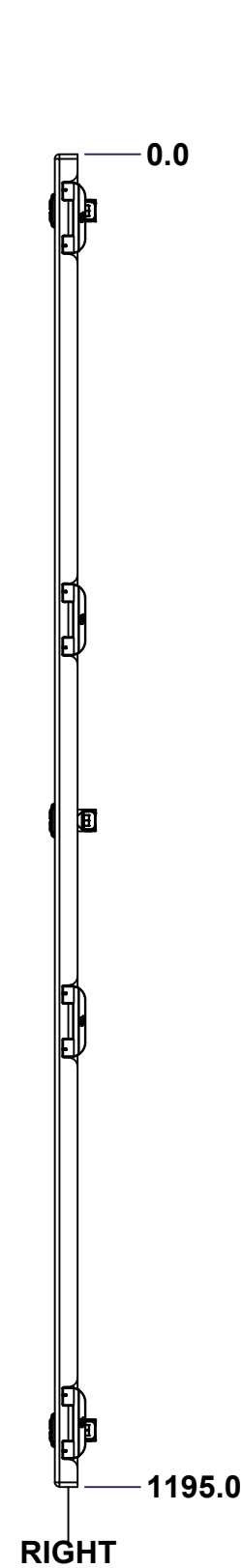
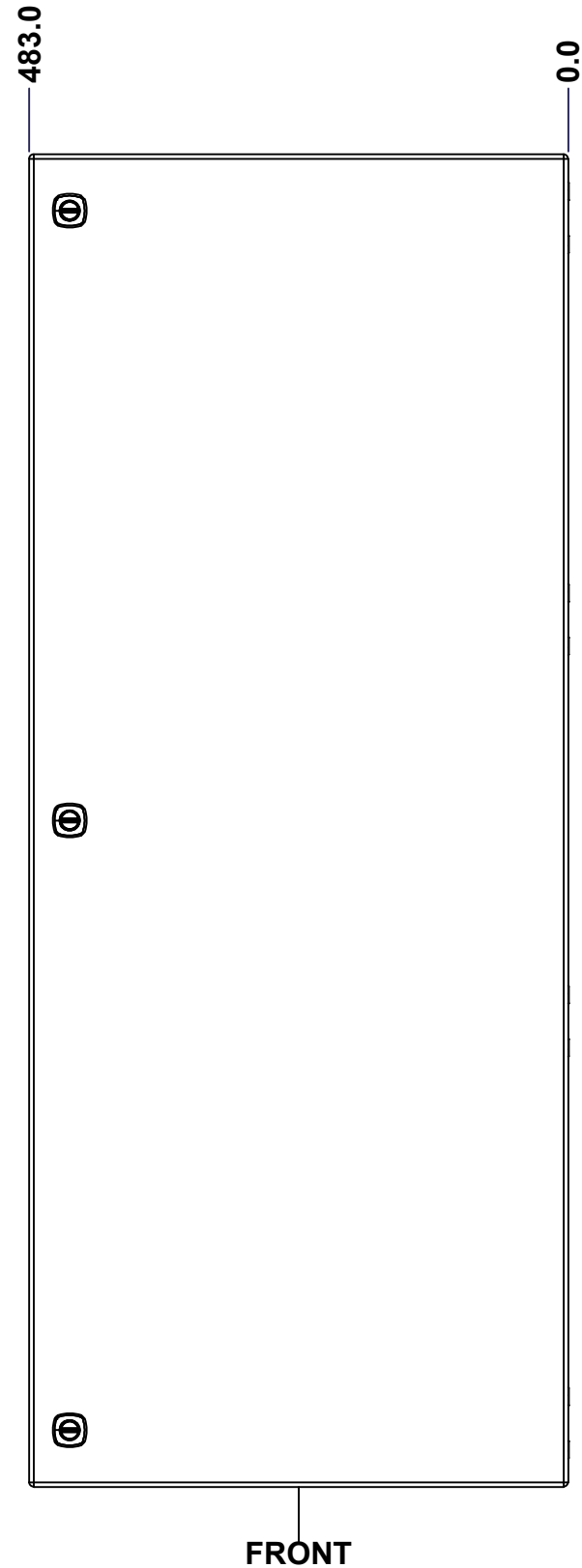
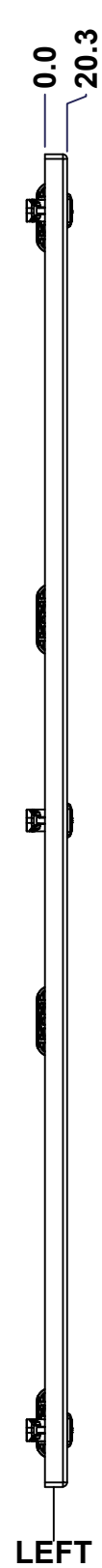
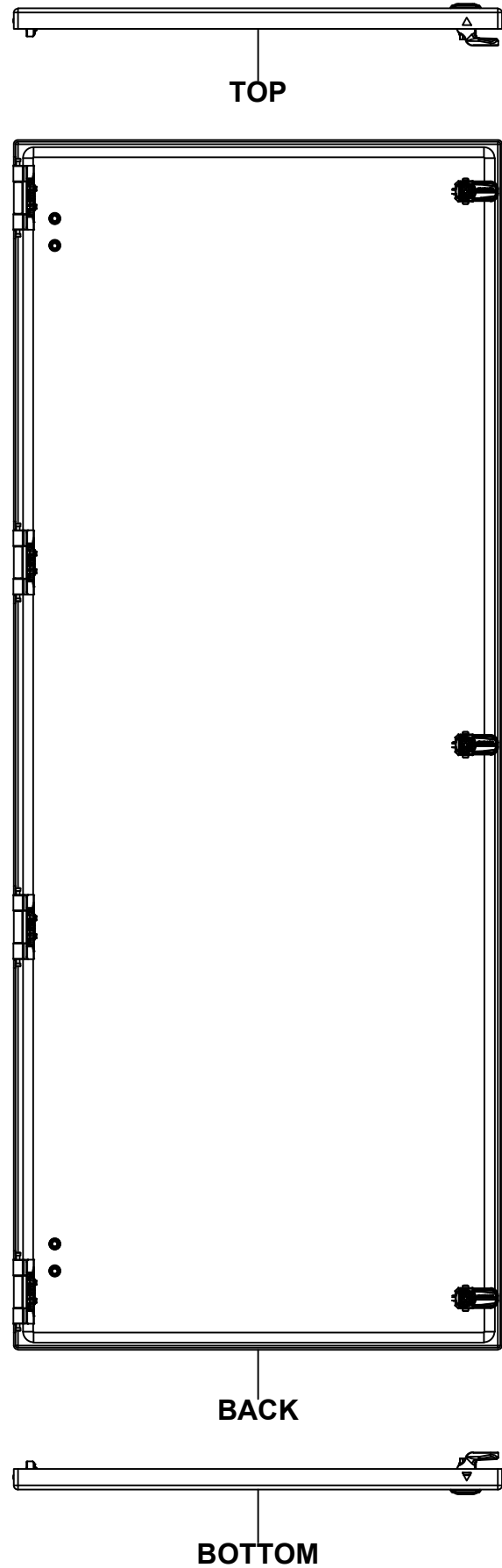

Isometric View



No.	Revisions	Date	By/Par

	Flatness Aplatissement Max 3.0mm
	Projection
Customer Client	Date
Drawn By Dessiné Par BoxCad: BoxCad	Date 06-Nov-14
Material Matière 14 Ga Cold Rolled A1008 CS Type B (1.7mm)	
Color Couleur Light Grey RAL7035	Finish Fini Textured
Description 6500Codd 1200mm x 400mm Top Cover	
Part Number Numéro Pièce 6500Codd1204TD	
Rev. 0	9 23

SEE BILL OF MATERIAL ON LAST PAGE

This drawing is confidential and must not be reproduced or used without the consent of EXM

Ce dessin est confidentiel et ne doit pas être reproduit ou utilisé sans le consentement de EXM

STANDARD FEATURES ARE NOT LISTED IN THIS HOLE TABLE

HOLE TABLE - FRONT VIEW (CUSTOM FEATURE ONLY)

CUT-OUT	XDIM	YDIM	DESCRIPTION
1	446.8	597.5	LOCK 880 SCQ4-SL @ 270.0°
2	446.8	1144.2	LOCK 880 SCQ4-SL @ 270.0°
3	446.8	50.8	LOCK 880 SCQ4-SL @ 270.0°
4	40.6	77.6	STANDOFF M6 x 10mm (Inside)
5	40.6	104.4	STANDOFF M6 x 10mm (Inside)
6	40.6	1117.4	STANDOFF M6 x 10mm (Inside)
7	40.6	1090.6	STANDOFF M6 x 10mm (Inside)

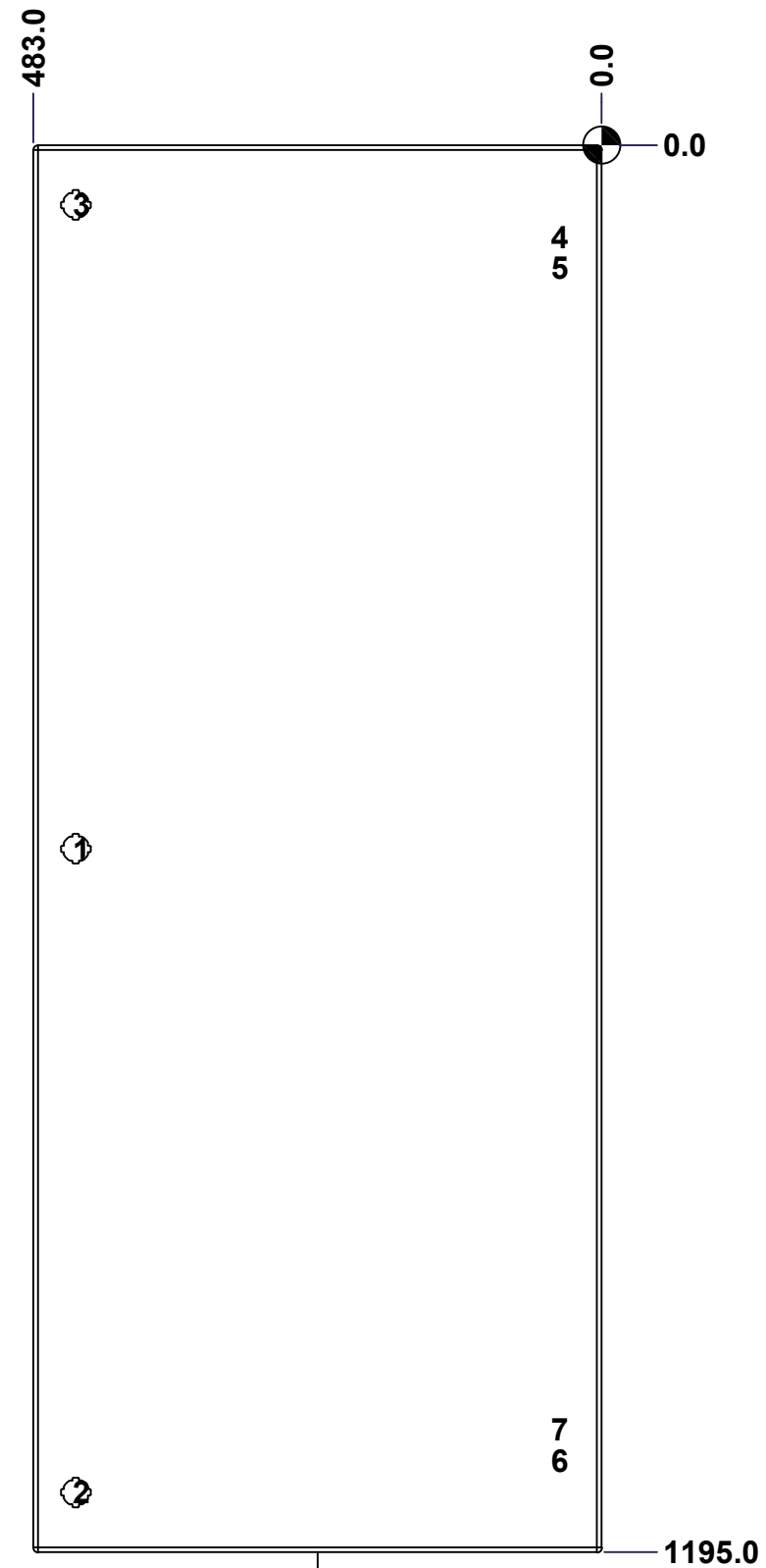

FRONT

	Description 6500Codd 1200mm x 400mm Top Cover	Status (NULL)
	Part Number Numéro Pièce 6500Codd1204TD	Rev. 0

This drawing is confidential and must not be reproduced or used without the consent of EXM

Ce dessin est confidentiel et ne doit pas être reproduit ou utilisé sans le consentement de EXM

No.	Revisions	Date	By/Par

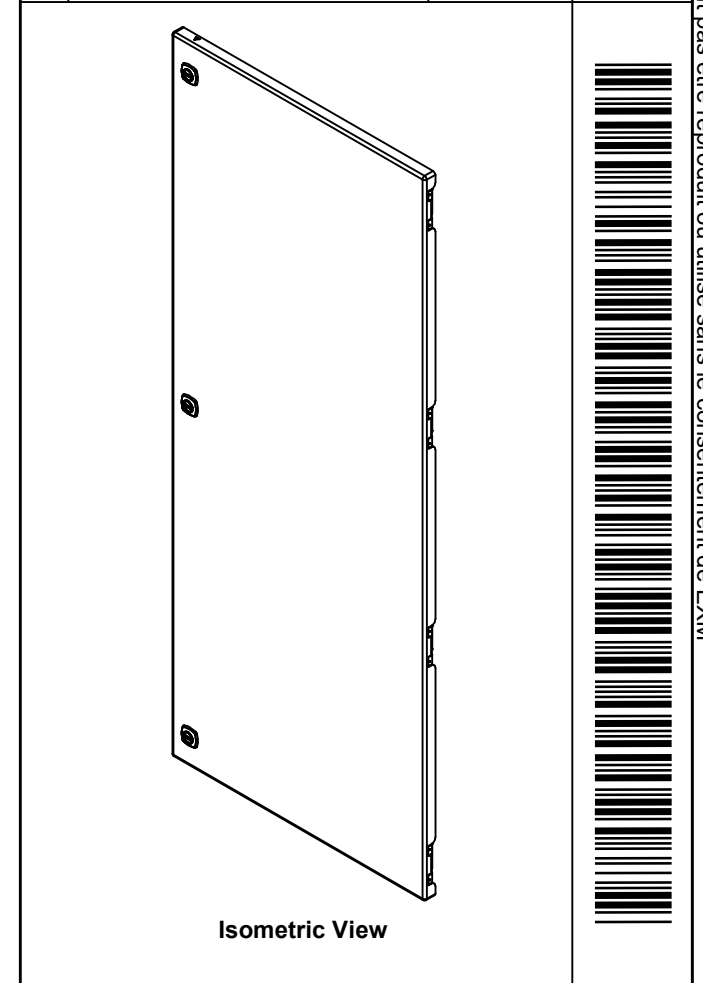

Tél: (450) 979-4373 Fax: (450) 979-4626 www.exmweb.com		Flatness Aplatissement
		Max 3.0mm
Customer Client		Date
Drawn By Dessiné Par BoxCad: BoxCad		Date 06-Nov-14
Material Matière 14 Ga Cold Rolled A1008 CS Type B (1.7mm)		
Color Couleur Light Grey RAL7035		Finish Fini Textured
Description		Detail Rev.
6500Codd 1200mm x 400mm Top Cover		
Part Number Numéro Pièce		Rev.
6500Codd1204TD		0
		11 23

Qty	Part Number	Rev	Description
4	STK-Q-08350	5	Standoff M6 x 10mm
3	STK-K-12500	19	5412 ES 1/4 Turn Lock
1	STK-P-03820R	0	Powder Paint (Light Grey / Rough Textured)
1	6500Codd1204TD-P	0	6500Codd 1200mm x 400mm Top Cover Part
1	6500Codd1204TD-G	0	6500Codd 1000mm x 1200mm Top Cover Gasket
4	STK-K-09800	10	5412 ES Hinge with 2 Captive Hinge Pins
Parts List			

This drawing is confidential and must not be reproduced or used without the consent of EXM

Ce dessin est confidentiel et ne doit pas être reproduit ou utilisé sans le consentement de EXM



TOP

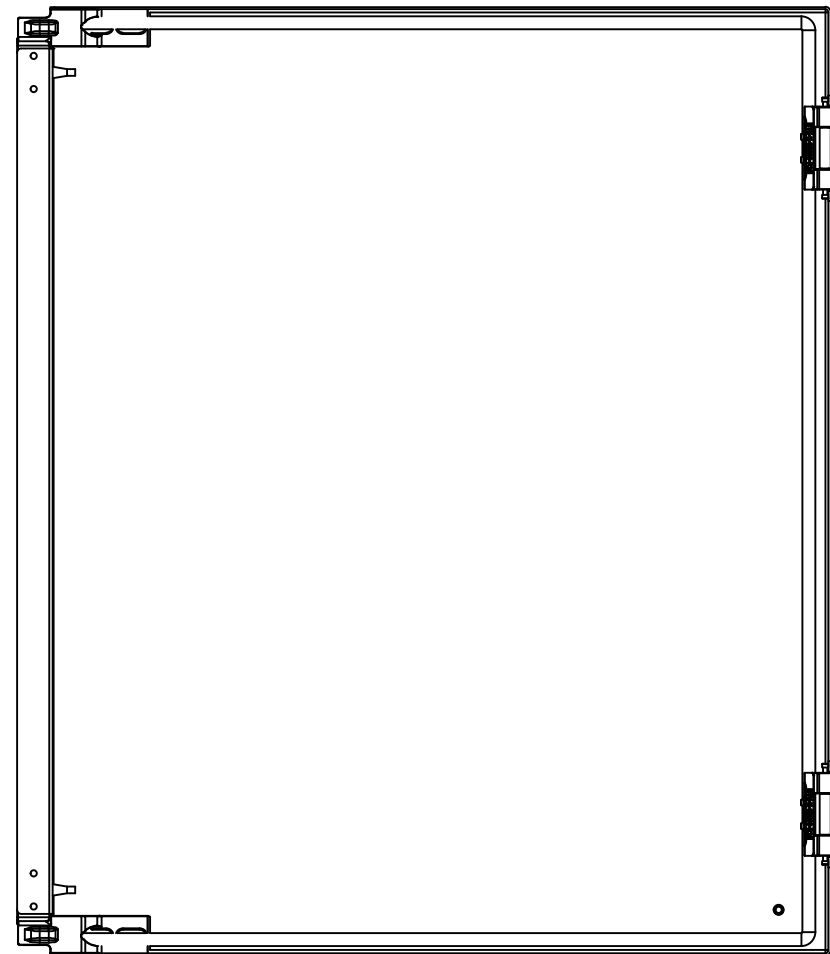

BACK

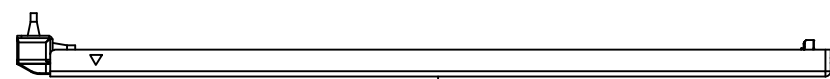

BOTTOM

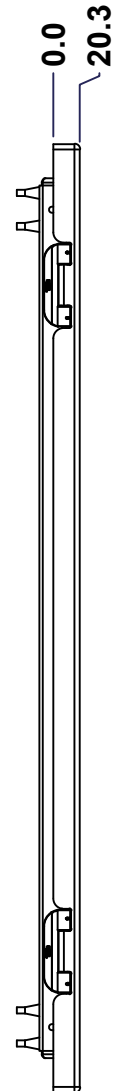

LEFT

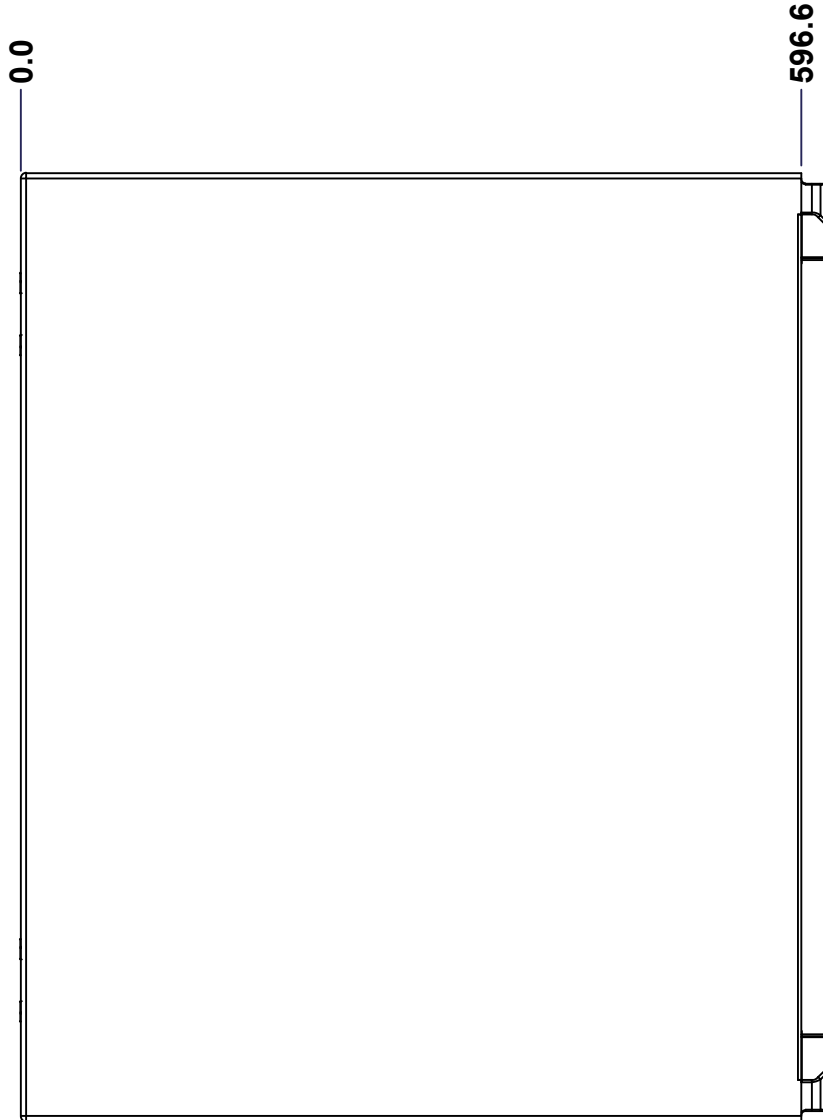

FRONT

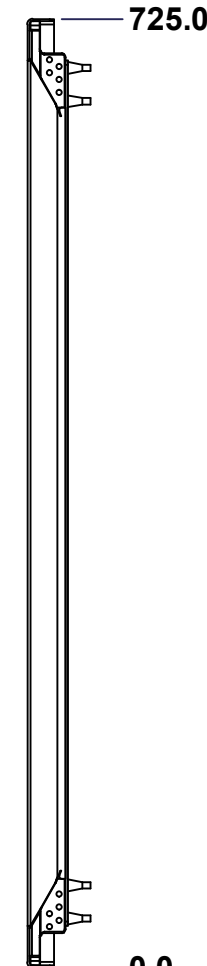

RIGHT

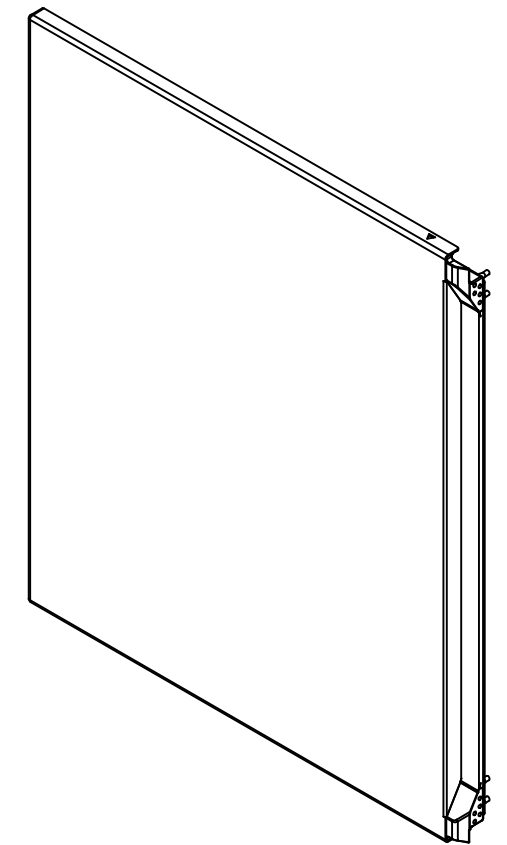

Isometric View

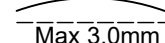
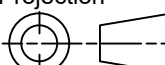

No.	Revisions	Date	By/Par

 Tél: (450) 979-4373 Fax: (450) 979-4626 www.exmweb.com		Flatness Aplatissement  Max 3.0mm Projection 
Customer Client	Date	
Drawn By Dessiné Par	BoxCad: BoxCad	Date 06-Nov-14
Material Matière	14 Ga Cold Rolled A1008 CS Type B (1.7mm)	
Color Couleur	Light Grey RAL7035	Finish Fini Textured
Description	Detail Rev.	
6500Codd 1000mm x 1200mm Front Flange Door		
Part Number Numéro Pièce	Rev.	12
6500Codd1204FL	0	23

SEE BILL OF MATERIAL ON LAST PAGE

This drawing is confidential and must not be reproduced or used without the consent of EXM

Ce dessin est confidentiel et ne doit pas être reproduit ou utilisé sans le consentement de EXM

STANDARD FEATURES ARE NOT LISTED IN THIS HOLE TABLE			
HOLE TABLE - FRONT VIEW (CUSTOM FEATURE ONLY)			
CUT-OUT	XDIM	YDIM	DESCRIPTION
1	40.0	35.0	GND STUD M6 x 16mm (Inside)

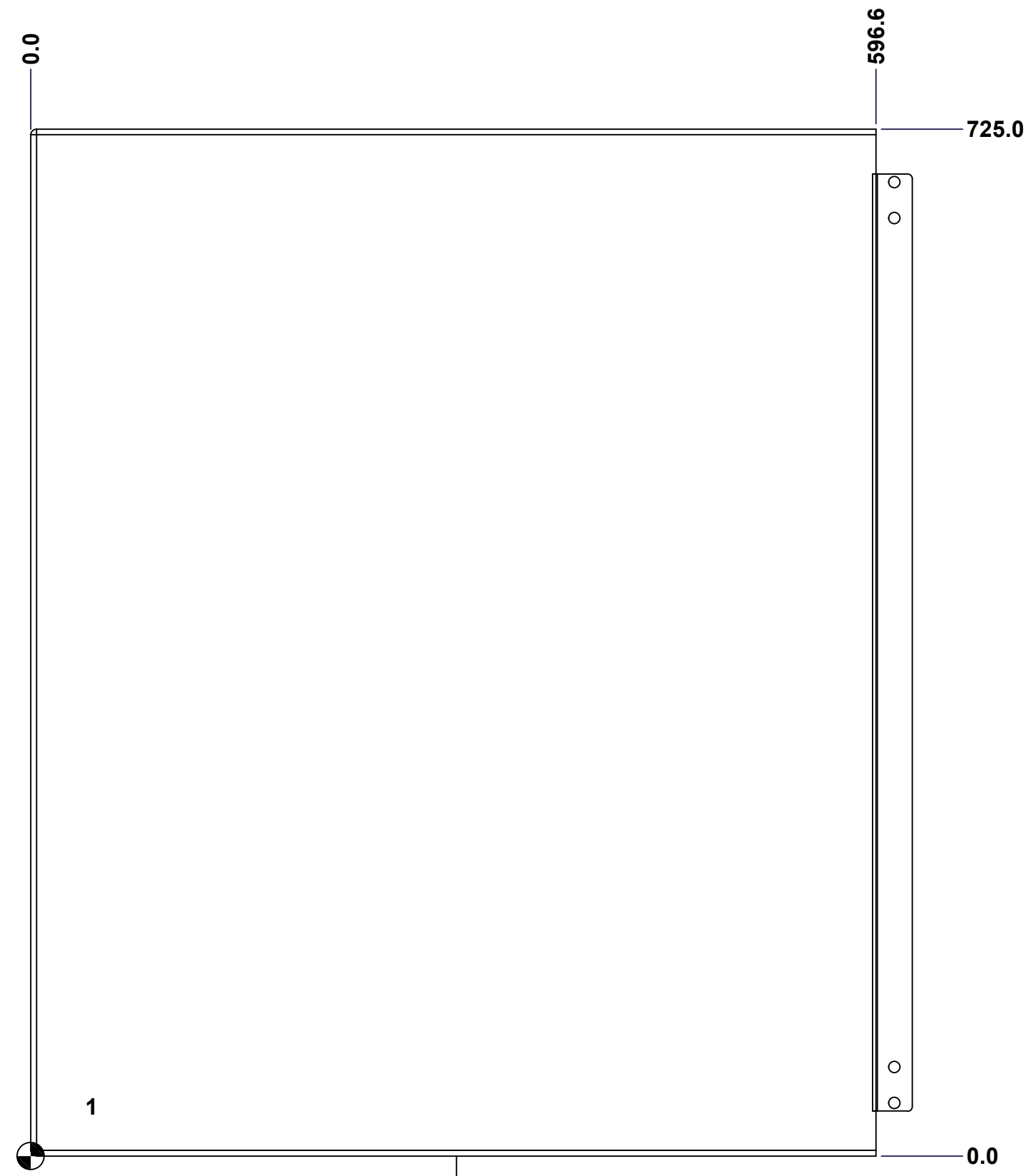

FRONT

	Description 6500Codd 1000mm x 1200mm Front Flange Door	Status (NULL)
	Part Number Numéro Pièce 6500Codd1204FL	Rev. 13 0 / 23

This drawing is confidential and must not be reproduced or used without the consent of EXM

Ce dessin est confidentiel et ne doit pas être reproduit ou utilisé sans le consentement de EXM

No.	Revisions	Date	By/Par

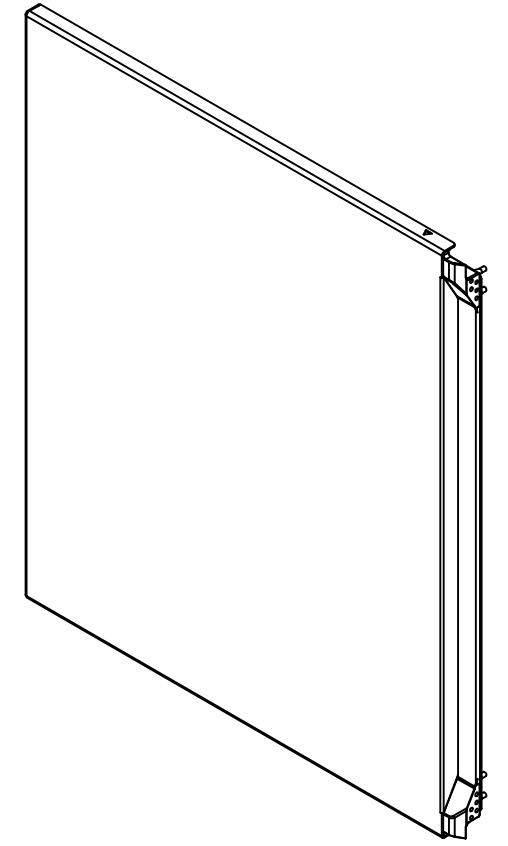

Isometric View



Tél: (450) 979-4373
 Fax: (450) 979-4626
www.exmweb.com

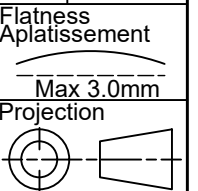

Customer Client	Date
Drawn By / Dessiné Par: BoxCad: BoxCad	Date: 06-Nov-14
Material / Matière: 14 Ga Cold Rolled A1008 CS Type B (1.7mm)	

Color / Couleur: Light Grey RAL7035	Finish / Fini: Textured
Description: 6500CDD 1000mm x 1200mm Front Flange Door	
Detail Rev.	

Qty	Part Number	Rev	Description
1	STK-Q-16080	0	Ground Stud M6 x 16mm Steel
1	STK-P-03820R	0	Powder Paint (Light Grey / Rough Textured)
1	STK-G-03200	8	5500 ESDD Lower Flange Door Gasket
1	STK-G-03100	8	5500 ESDD Upper Flange Door Gasket
1	STK-G-00701	0	1" x 1/4" Self-Adhesive Neoprene Gasket
1	6500CDD1204FL-P	0	6500CDD 1000mm x 1200mm Front Flange Door Part
1	6500CDD1204FL-G	0	6500CDD 1000mm x 1200mm Front Flange Door Gasket
2	STK-K-09800	10	5412 ES Hinge with 2 Captive Hinge Pins

Part Number / Numéro Pièce: 6500CDD1204FL	Rev. / Révis: 0	14 / 23
--	------------------------	---------

This drawing is confidential and must not be reproduced or used without the consent of EXM

Ce dessin est confidentiel et ne doit pas être reproduit ou utilisé sans le consentement de EXM

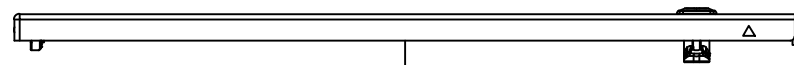

TOP

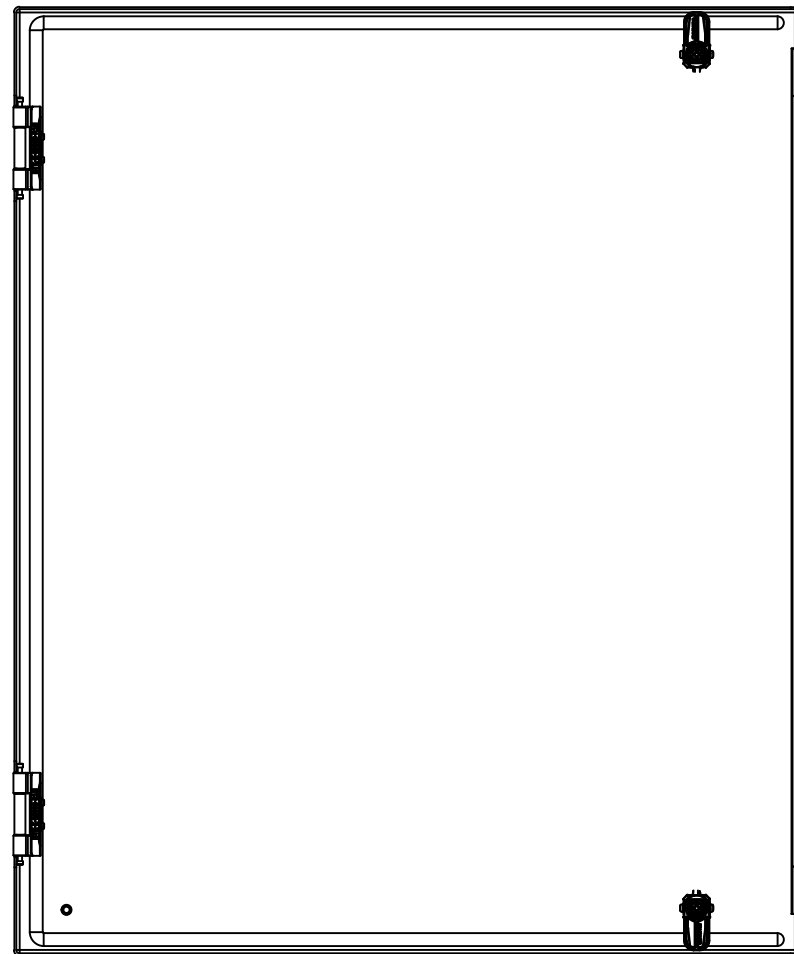

BACK

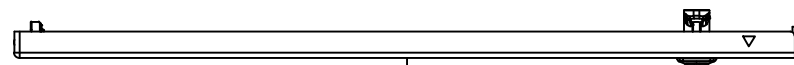

BOTTOM

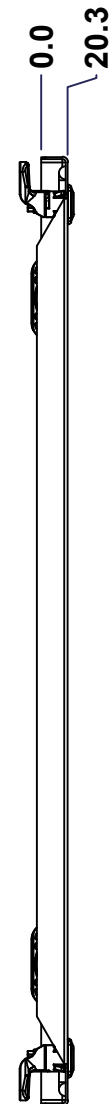

LEFT

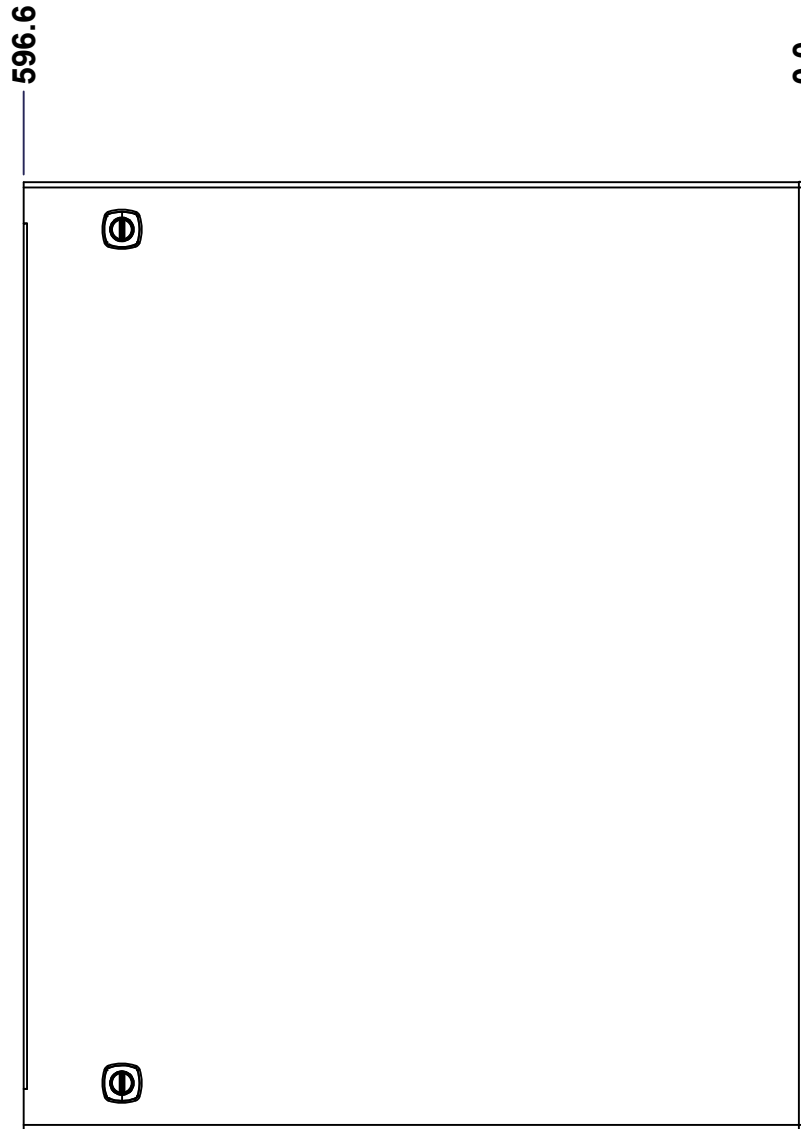

FRONT

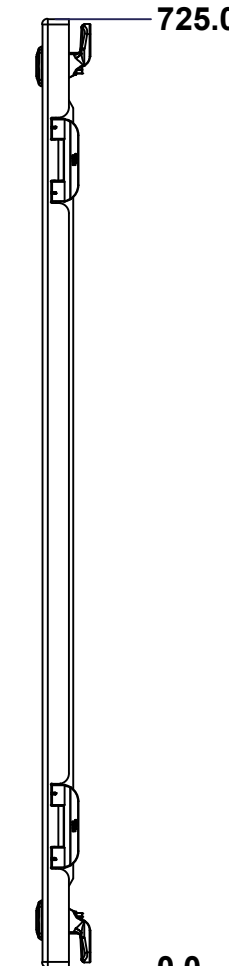

RIGHT

No.	Revisions	Date	By/Par

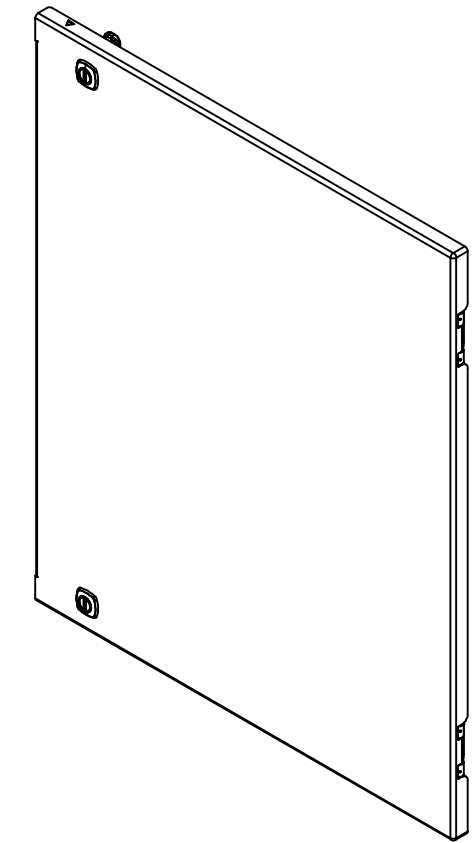

Isometric View

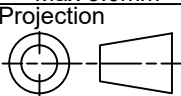

 Tél: (450) 979-4373 Fax: (450) 979-4626 www.exmweb.com		Flatness Aplatissement Max 3.0mm Projection 
Customer Client	Date	
Drawn By Dessiné Par	BoxCad: BoxCad	Date 06-Nov-14
Material Matière	14 Ga Cold Rolled A1008 CS Type B (1.7mm)	
Color Couleur	Light Grey RAL7035	Finish Fini Textured
Description	Detail Rev.	
6500Codd 1000mm x 1200mm Front Lock Door		
Part Number Numéro Pièce	Rev.	15
6500Codd1204FR	0	23

SEE BILL OF MATERIAL ON LAST PAGE

This drawing is confidential and must not be reproduced or used without the consent of EXM

Ce dessin est confidentiel et ne doit pas être reproduit ou utilisé sans le consentement de EXM

STANDARD FEATURES ARE NOT LISTED IN THIS HOLE TABLE

HOLE TABLE - FRONT VIEW (CUSTOM FEATURE ONLY)

CUT-OUT	XDIM	YDIM	DESCRIPTION
1	40.0	35.0	GND STUD M6 x 16mm (Inside)
2	521.6	688.8	LOCK 880 SCQ4-SL @ 90.0°
3	521.6	36.2	LOCK 880 SCQ4-SL @ 270.0°

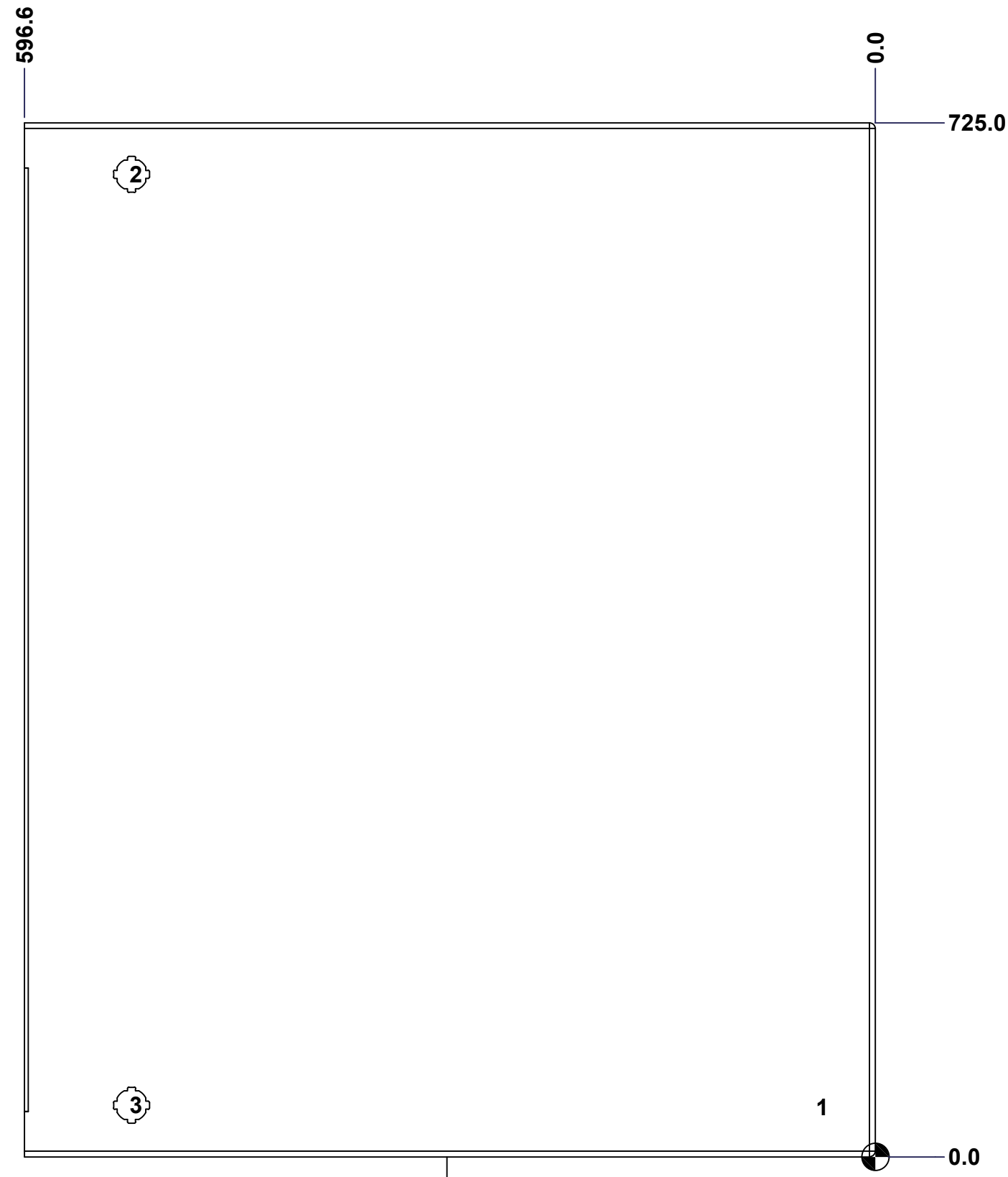

FRONT

	Description 6500Codd 1000mm x 1200mm Front Lock Door		Status (NULL)
	Part Number Numéro Pièce 6500Codd1204FR		Rev. 16 0 / 23

This drawing is confidential and must not be reproduced or used without the consent of EXM

Ce dessin est confidentiel et ne doit pas être reproduit ou utilisé sans le consentement de EXM

No.	Revisions	Date	By/Par

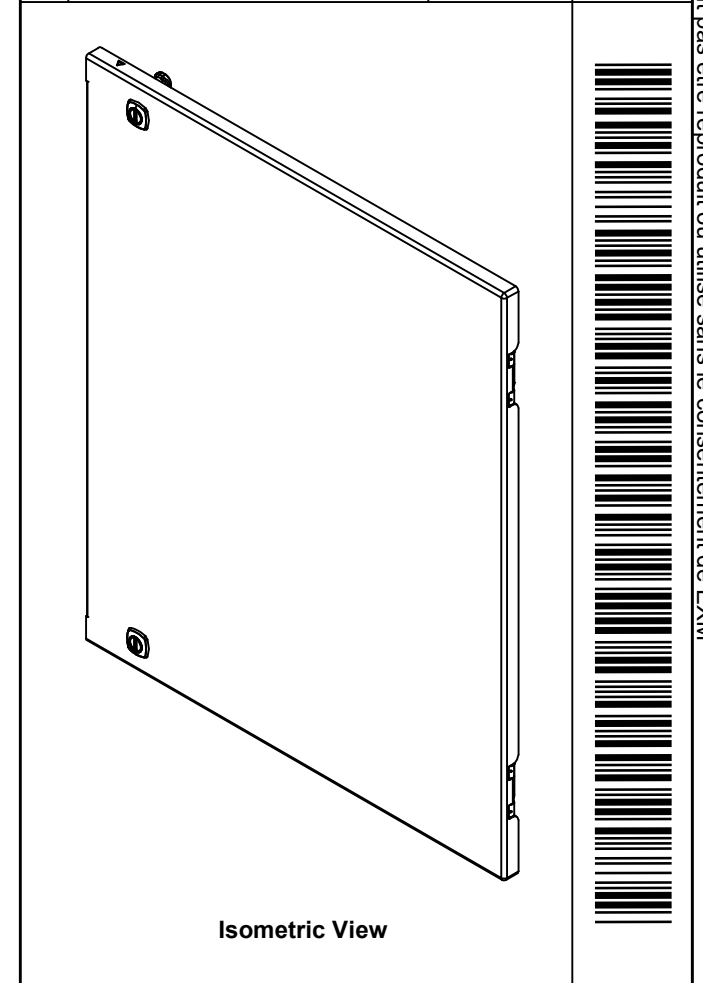



Tél: (450) 979-4373
Fax: (450) 979-4626
www.exmweb.com

Flatness
Aplatissement
Max 3.0mm

Projection

Customer Client	Date
Drawn By / Dessiné Par: BoxCad: BoxCad	Date: 06-Nov-14
Material / Matière: 14 Ga Cold Rolled A1008 CS Type B (1.7mm)	

Color / Couleur: Light Grey RAL7035	Finish / Fini: Textured
Description: 6500CDD 1000mm x 1200mm Front Lock Door	
Detail Rev.	

Part Number / Numéro Pièce: 6500CDD1204FR	Rev. 0	17 / 23
--	--------	---------

Qty	Part Number	Rev	Description
2	STK-K-12500	19	5412 ES 1/4 Turn Lock
1	STK-Q-16080	0	Ground Stud M6 x 16mm Steel
1	STK-P-03820R	0	Powder Paint (Light Grey / Rough Textured)
1	6500CDD1204FR-P	0	6500CDD 1000mm x 1200mm Front Lock Door Part
1	6500CDD1204FR-G	0	6500CDD 1000mm x 1200mm Front Lock Door Gasket
2	STK-K-09800	10	5412 ES Hinge with 2 Captive Hinge Pins
Parts List			

This drawing is confidential and must not be reproduced or used without the consent of EXM

Ce dessin est confidentiel et ne doit pas être reproduit ou utilisé sans le consentement de EXM



TOP

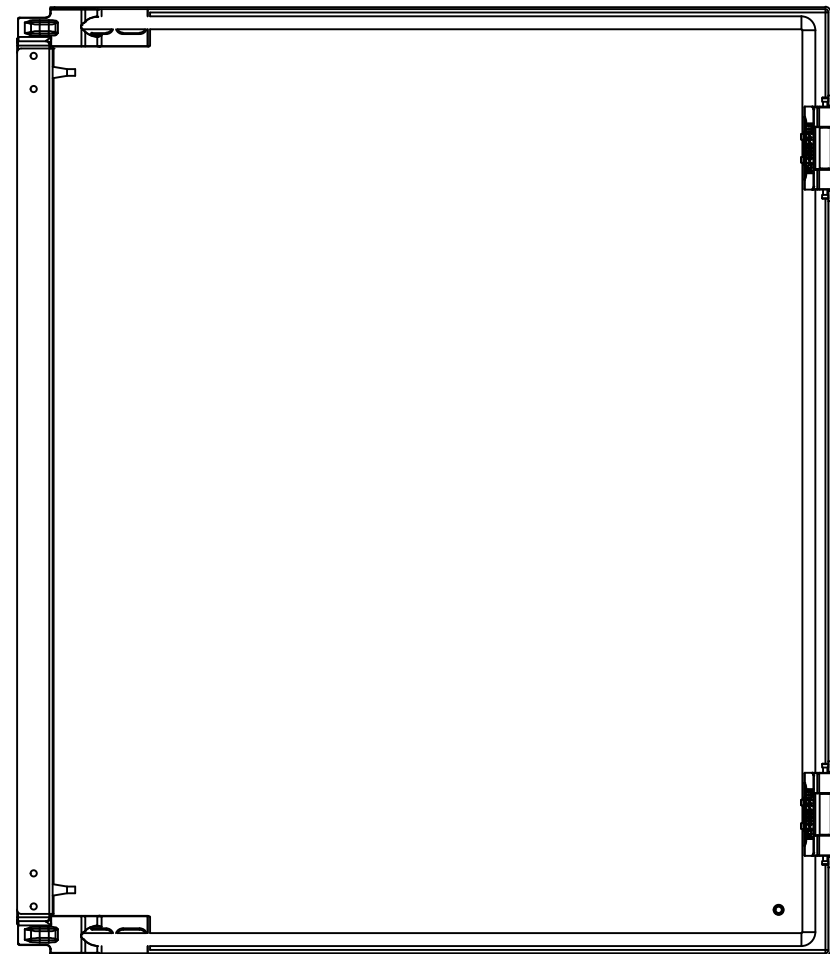

BACK

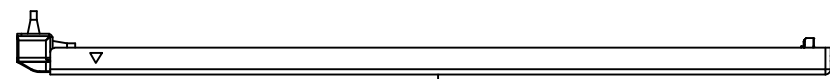

BOTTOM

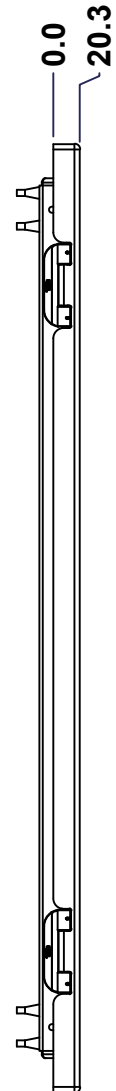

LEFT

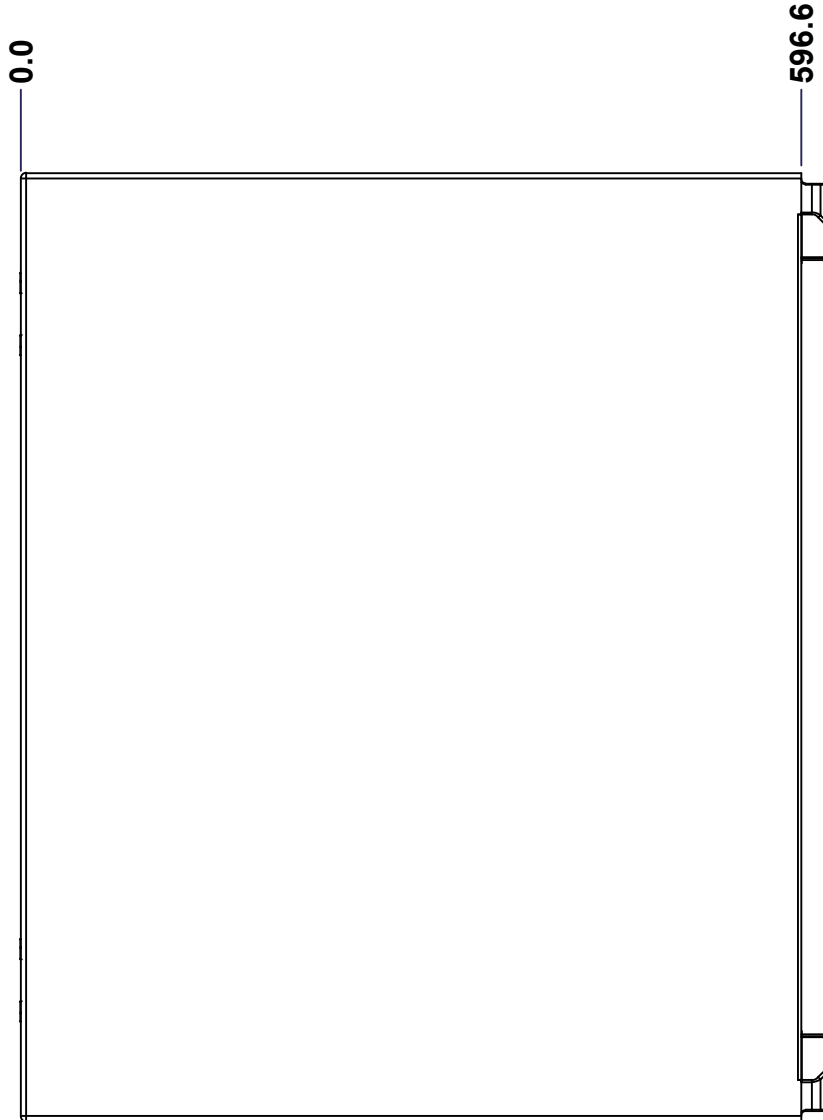

FRONT

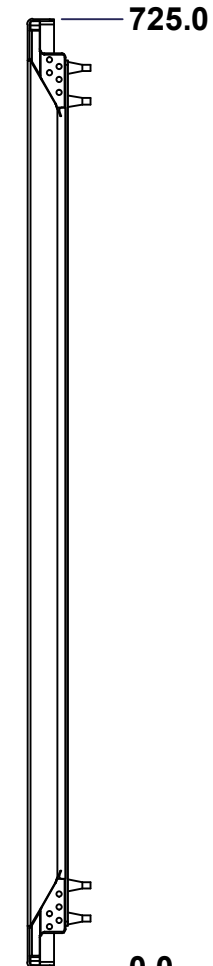

RIGHT

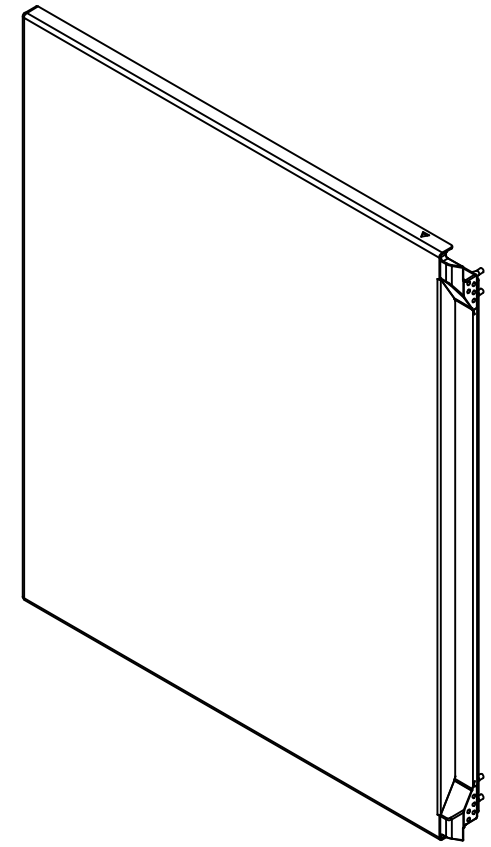

Isometric View

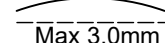
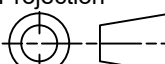

No.	Revisions	Date	By/Par

 Tél: (450) 979-4373 Fax: (450) 979-4626 www.exmweb.com		Flatness Aplatissement  Max 3.0mm Projection 
Customer Client	Date	
Drawn By Dessiné Par	BoxCad: BoxCad	Date 06-Nov-14
Material Matière	14 Ga Cold Rolled A1008 CS Type B (1.7mm)	
Color Couleur	Light Grey RAL7035	Finish Fini Textured
Description	Detail Rev.	
6500Codd 1000mm x 1200mm Back Flange Door		
Part Number Numéro Pièce	Rev.	18
6500Codd1204BL	0	23

SEE BILL OF MATERIAL ON LAST PAGE

This drawing is confidential and must not be reproduced or used without the consent of EXM

Ce dessin est confidentiel et ne doit pas être reproduit ou utilisé sans le consentement de EXM

STANDARD FEATURES ARE NOT LISTED IN THIS HOLE TABLE

HOLE TABLE - FRONT VIEW (CUSTOM FEATURE ONLY)

CUT-OUT	XDIM	YDIM	DESCRIPTION
1	40.0	35.0	GND STUD M6 x 16mm (Inside)

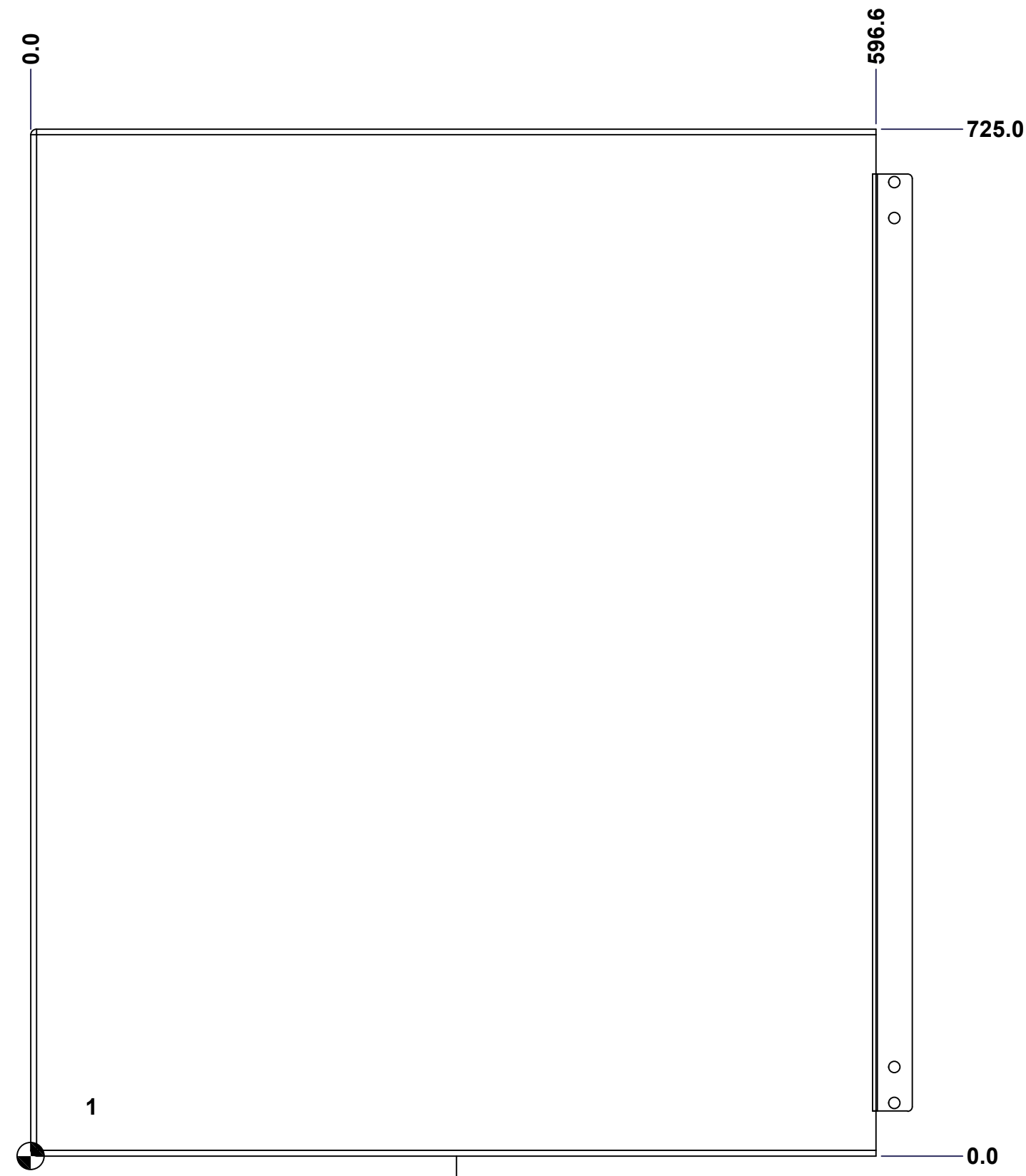

FRONT

	Description 6500Codd 1000mm x 1200mm Back Flange Door	Status (NULL)
	Part Number Numéro Pièce 6500Codd1204BL	Rev. 19 0 23

This drawing is confidential and must not be reproduced or used without the consent of EXM

Ce dessin est confidentiel et ne doit pas être reproduit ou utilisé sans le consentement de EXM

No.	Revisions	Date	By/Par

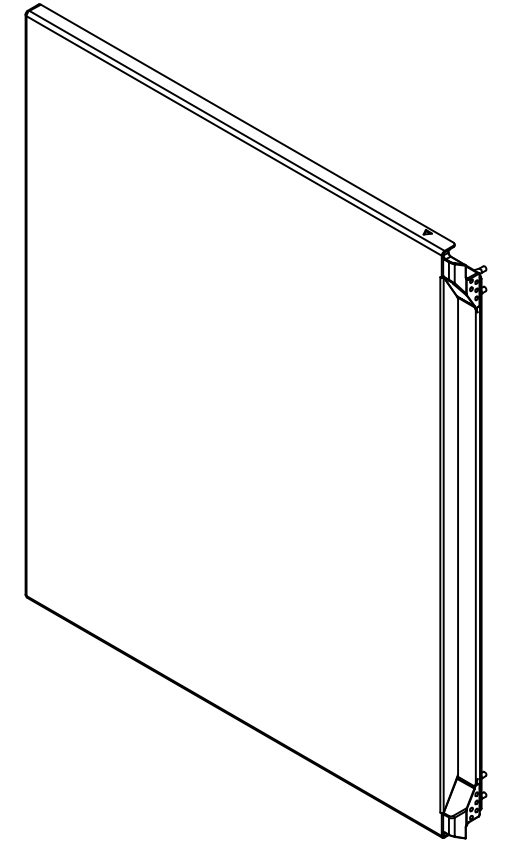

Isometric View

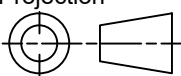
 Tél: (450) 979-4373 Fax: (450) 979-4626 www.exmweb.com	Flatness Aplatissement	Max 3.0mm
	Projection	
Customer Client	Date	
Drawn By Dessiné Par	BoxCad: BoxCad	Date 06-Nov-14
Material Matière	14 Ga Cold Rolled A1008 CS Type B (1.7mm)	
Color Couleur	Light Grey RAL7035	Finish Fini Textured
Description	Detail Rev.	
6500Codd 1000mm x 1200mm Back Flange Door		
Part Number Numéro Pièce	Rev.	20
6500Codd1204BL	0	23

Qty	Part Number	Rev	Description
1	STK-Q-16080	0	Ground Stud M6 x 16mm Steel
1	STK-P-03820R	0	Powder Paint (Light Grey / Rough Textured)
1	STK-G-03200	8	5500 ESDD Lower Flange Door Gasket
1	STK-G-03100	8	5500 ESDD Upper Flange Door Gasket
1	STK-G-00701	0	1" x 1/4" Self-Adhesive Neoprene Gasket
1	6500Codd1204BL-P	0	6500Codd 1000mm x 1200mm Back Flange Door Part
1	6500Codd1204BL-G	0	6500Codd 1000mm x 1200mm Back Flange Door Gasket
2	STK-K-09800	10	5412 ES Hinge with 2 Captive Hinge Pins
Parts List			

This drawing is confidential and must not be reproduced or used without the consent of EXM

Ce dessin est confidentiel et ne doit pas être reproduit ou utilisé sans le consentement de EXM

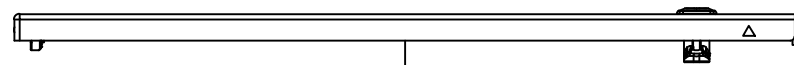

TOP

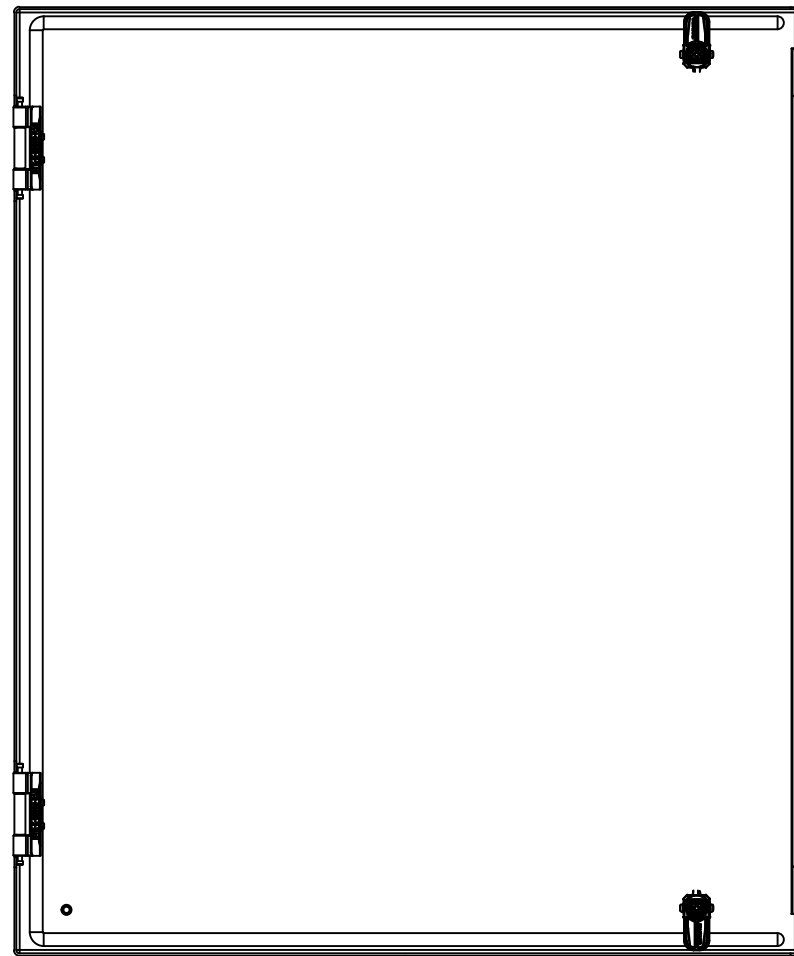

BACK

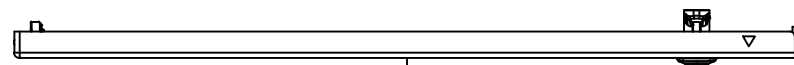

BOTTOM

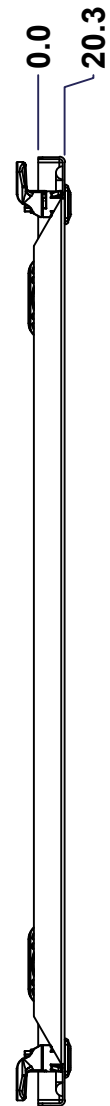

LEFT

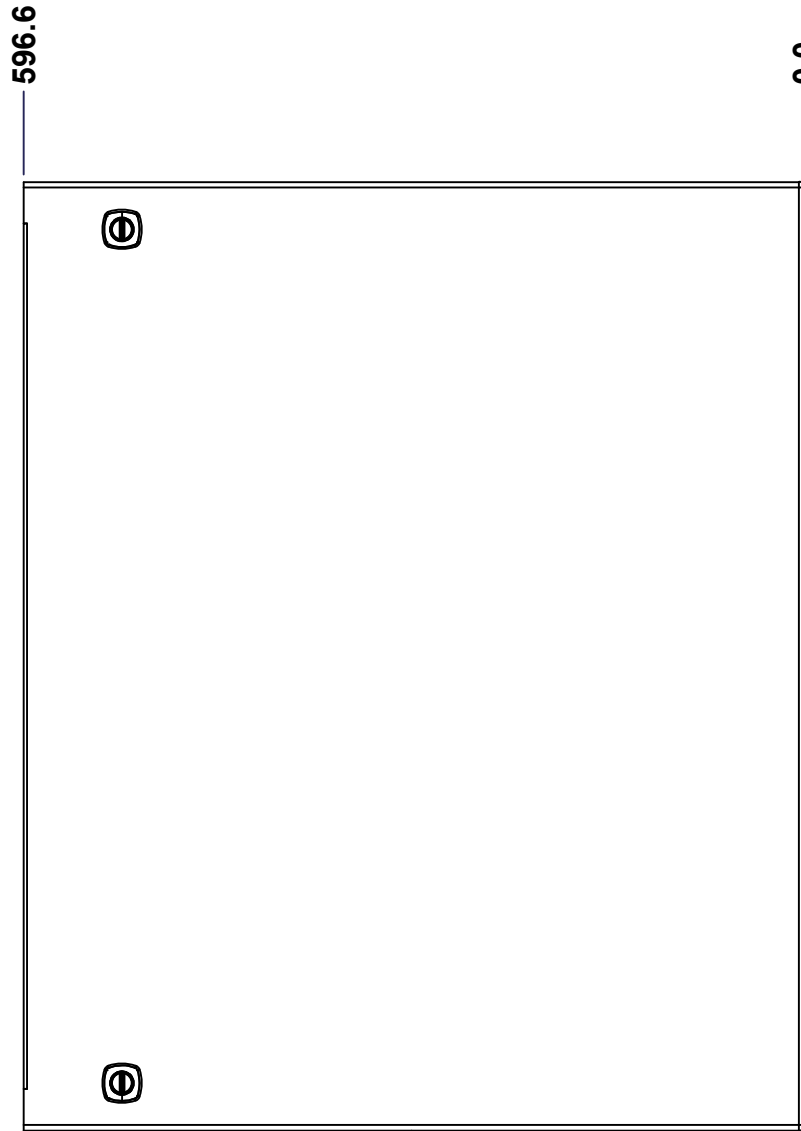

FRONT

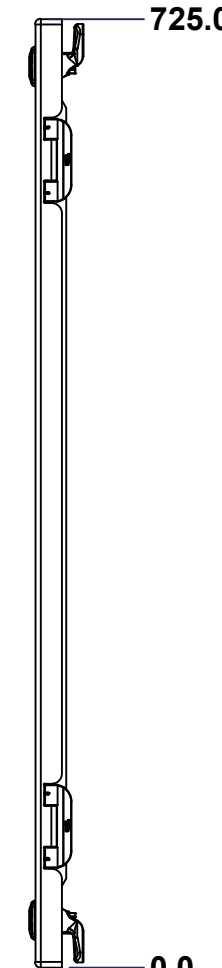

RIGHT

No.	Revisions	Date	By/Par

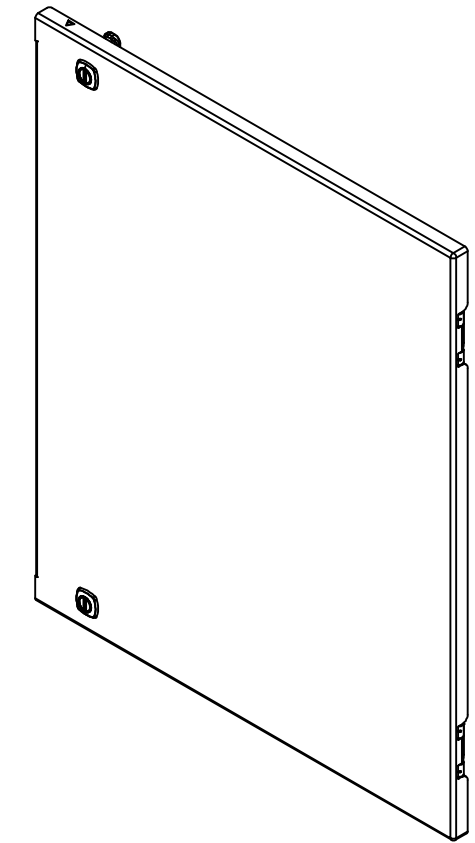

Isometric View

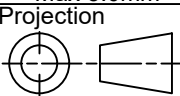

 Tél: (450) 979-4373 Fax: (450) 979-4626 www.exmweb.com		Flatness Aplatissement Max 3.0mm Projection 
Customer Client	Date	
Drawn By Dessiné Par	BoxCad: BoxCad	Date 06-Nov-14
Material Matière	14 Ga Cold Rolled A1008 CS Type B (1.7mm)	
Color Couleur	Light Grey RAL7035	Finish Fini Textured
Description	Detail Rev.	
6500Codd 1000mm x 1200mm Back Lock Door		
Part Number Numéro Pièce	Rev.	21
6500Codd1204BR	0	23

SEE BILL OF MATERIAL ON LAST PAGE

This drawing is confidential and must not be reproduced or used without the consent of EXM

Ce dessin est confidentiel et ne doit pas être reproduit ou utilisé sans le consentement de EXM

STANDARD FEATURES ARE NOT LISTED IN THIS HOLE TABLE

HOLE TABLE - FRONT VIEW (CUSTOM FEATURE ONLY)

CUT-OUT	XDIM	YDIM	DESCRIPTION
1	40.0	35.0	GND STUD M6 x 16mm (Inside)
2	521.6	688.8	LOCK 880 SCQ4-SL @ 90.0°
3	521.6	36.2	LOCK 880 SCQ4-SL @ 270.0°

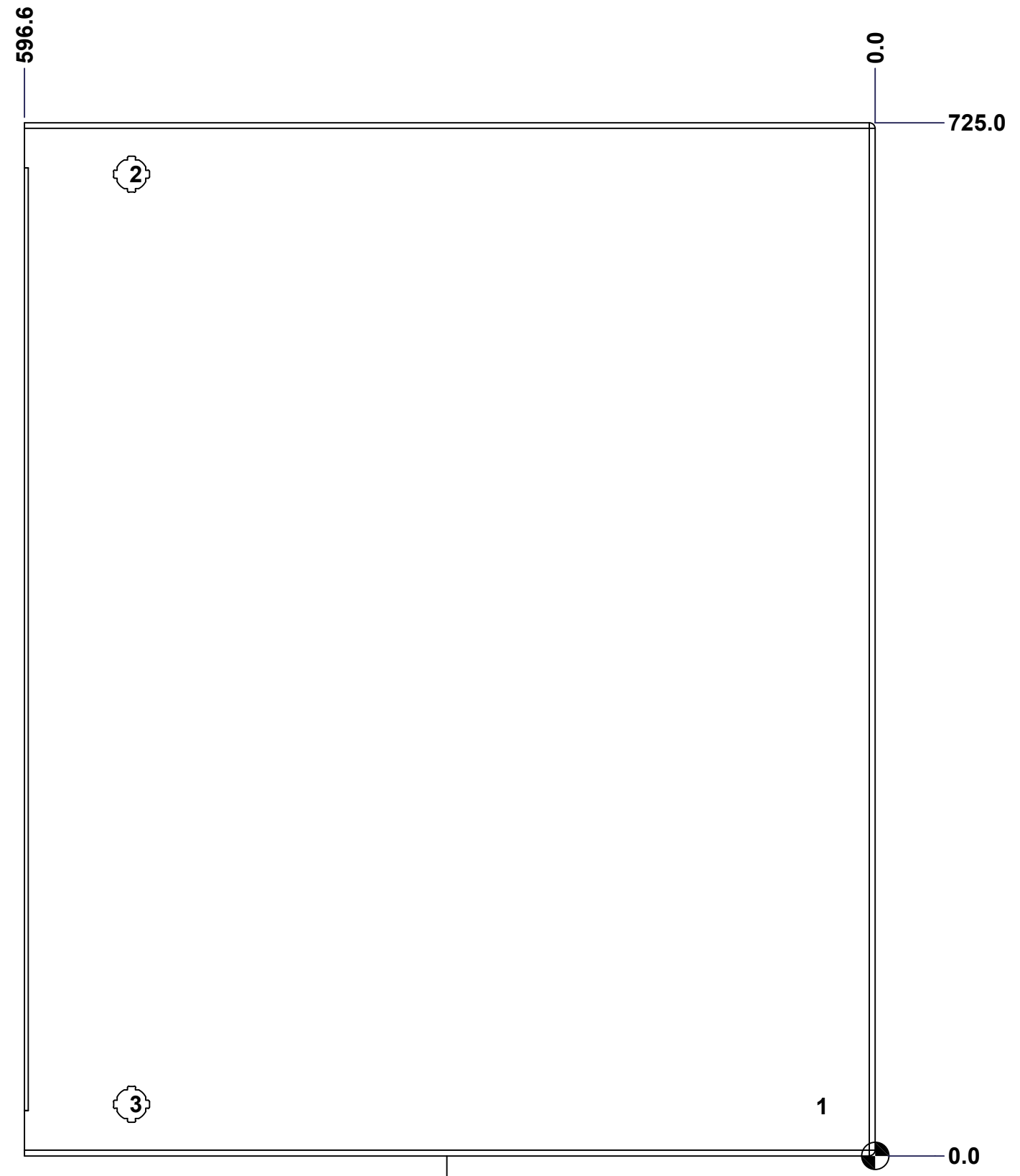

FRONT

	Description 6500Codd 1000mm x 1200mm Back Lock Door	Status (NULL)
	Part Number Numéro Pièce 6500Codd1204BR	Rev. 0

22
23

This drawing is confidential and must not be reproduced or used without the consent of EXM

Ce dessin est confidentiel et ne doit pas être reproduit ou utilisé sans le consentement de EXM

No.	Revisions	Date	By/Par

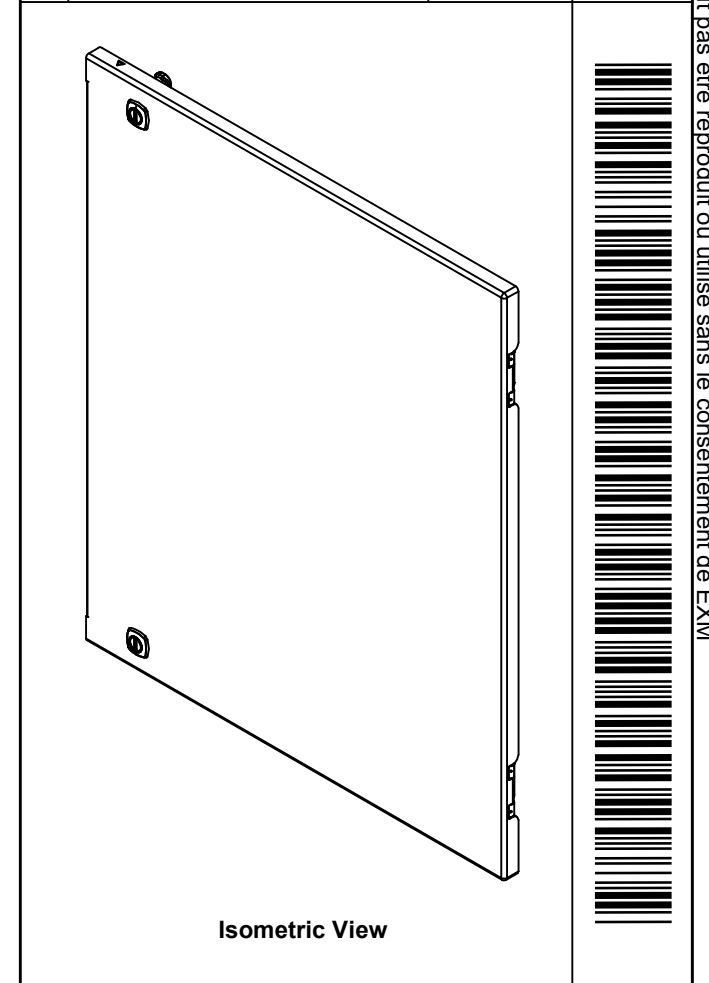

EXM
www.exmweb.com

Tél: (450) 979-4373
Fax: (450) 979-4626

Flatness
Aplatissement
Max 3.0mm

Projection

Customer Client	Date
Drawn By / Dessiné Par: BoxCad: BoxCad	Date: 06-Nov-14
Material / Matière: 14 Ga Cold Rolled A1008 CS Type B (1.7mm)	

Color / Couleur: Light Grey RAL7035	Finish / Fini: Textured
Description: 6500CDD 1000mm x 1200mm Back Lock Door	
Part Number / Numéro Pièce: 6500CDD1204BR	Rev. / Révis: 0
	23
	23

Qty	Part Number	Rev	Description
2	STK-K-12500	19	5412 ES 1/4 Turn Lock
1	STK-Q-16080	0	Ground Stud M6 x 16mm Steel
1	STK-P-03820R	0	Powder Paint (Light Grey / Rough Textured)
1	6500CDD1204BR-P	0	6500CDD 1000mm x 1200mm Back Lock Door Part
1	6500CDD1204BR-G	0	6500CDD 1000mm x 1200mm Back Lock Door Gasket
2	STK-K-09800	10	5412 ES Hinge with 2 Captive Hinge Pins
Parts List			

This drawing is confidential and must not be reproduced or used without the consent of EXM

Ce dessin est confidentiel et ne doit pas être reproduit ou utilisé sans le consentement de EXM

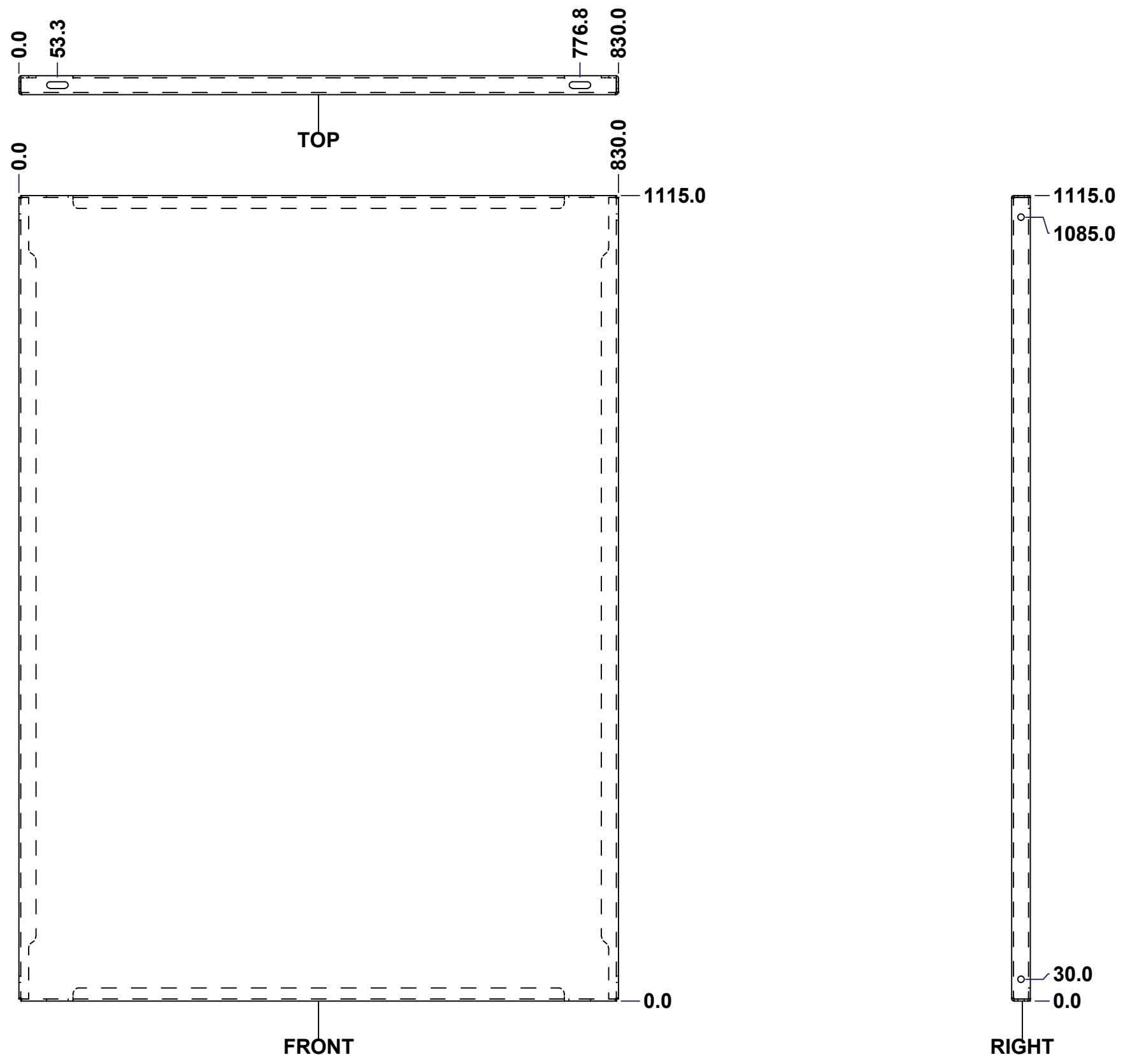

No.	Revisions	Date	By/Par

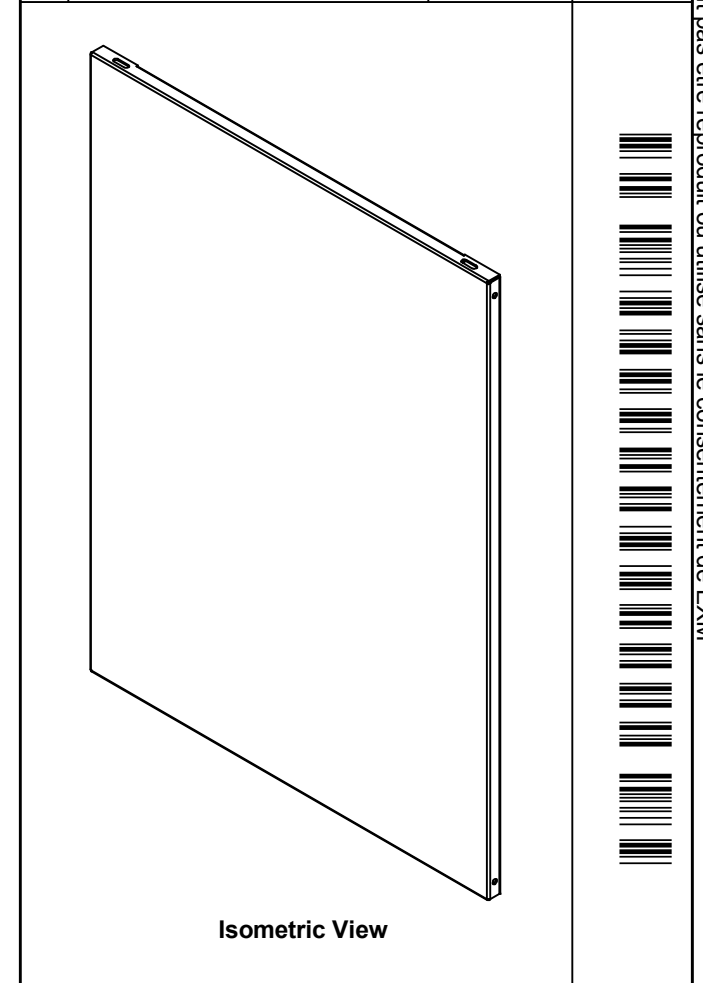

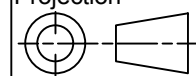
 Tél: (450) 979-4373 Fax: (450) 979-4626 www.exmweb.com		Flatness Aplatissement Max 3.0mm
Projection 		
Customer Client	Date	
Drawn By / Dessiné Par: BoxCad	Date: 1/23/2007	
Material / Matière	See Part List	
Color / Couleur	See Part List	Finish / Fini: See Part List
Description: 886 SP - Inner Panel		Detail Rev.
Part Number / Numéro Pièce: 886SP1200CO		Rev. 1/2

Qty	Part Number	Rev	Description	Material	Color	Finish
1	STK-P-02401S	0	Powder Paint (White / Smooth)	Polyester-Epoxy Hybrid	White RAL9003	Smooth
1				12 Ga Galvanized	Galvanized	Galvanized

Parts List

This drawing is confidential and must not be reproduced or used without the consent of EXM

Ce dessin est confidentiel et ne doit pas être reproduit ou utilisé sans le consentement de EXM

Table 1			FRONT VIEW
CUT-OUT	XDIM	YDIM	DESCRIPTION

All knockouts are actual size / Les disques défonçables sont grandeur réel

No.	Revisions	Date	By/Par

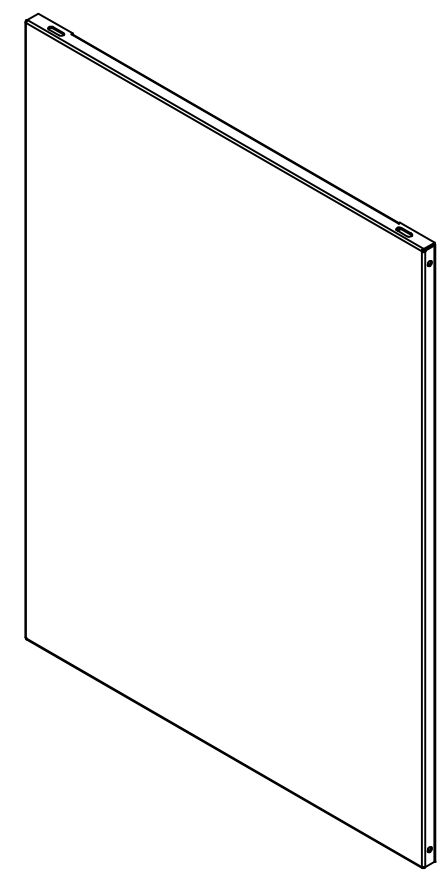
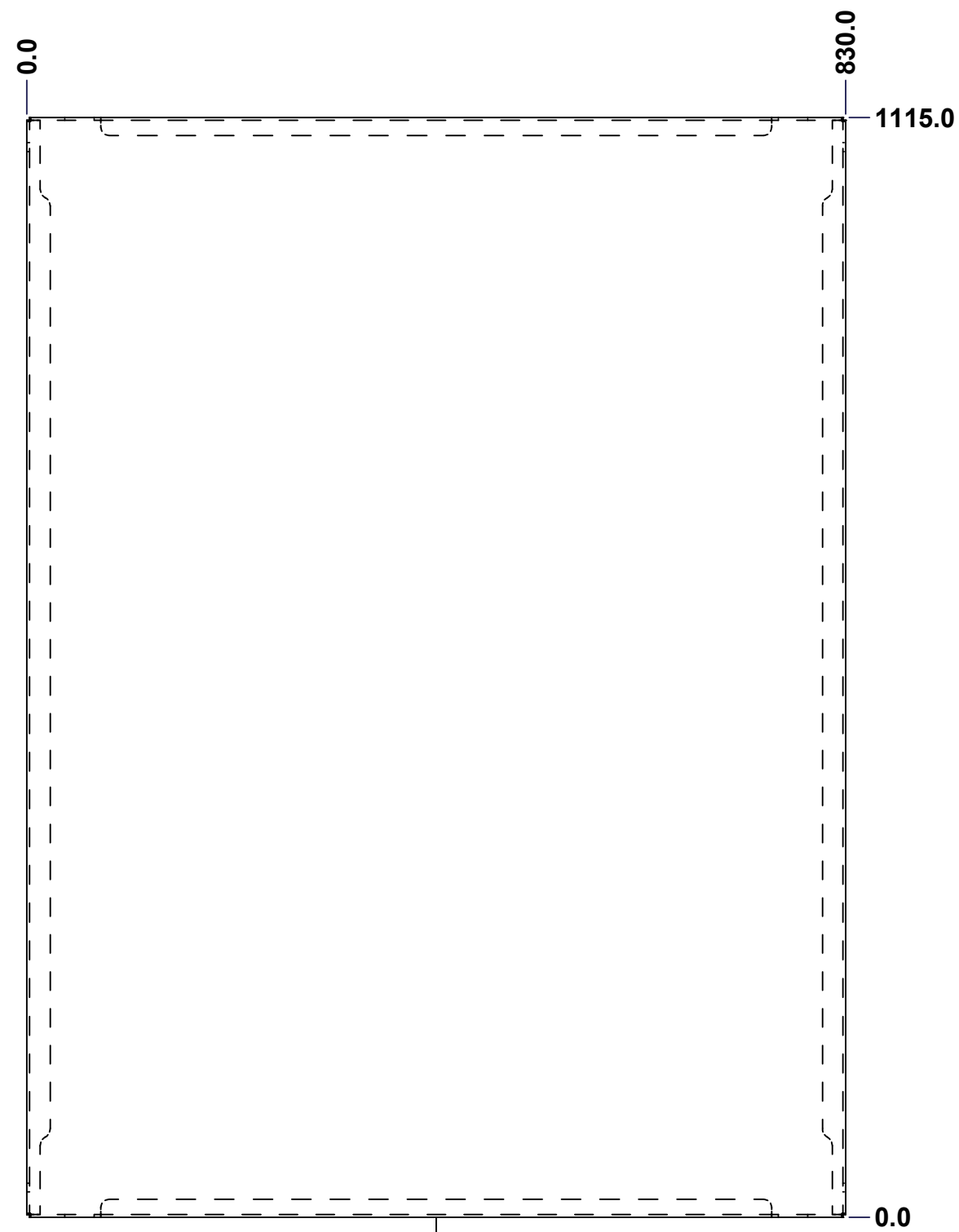

Isometric View

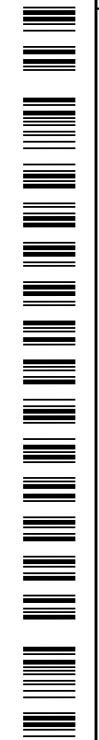

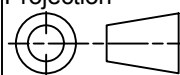
 Tél: (450) 979-4373 Fax: (450) 979-4626 www.exmweb.com		Flatness Aplatissement Max 3.0mm Projection 
Customer Client	Date	
Drawn By Dessiné Par BoxCad	Date 1/23/2007	
Material Matière	See Part List	
Color Couleur	See Part List	Finish Fini See Part List
Description 886 SP - Inner Panel		Detail Rev.
Part Number Numéro Pièce 886SP1200CO	Rev. 0	2 2