

This drawing is confidential and must not be reproduced or used without the consent of EXM

Ce dessin est confidentiel et ne doit pas être reproduit ou utilisé sans le consentement de EXM

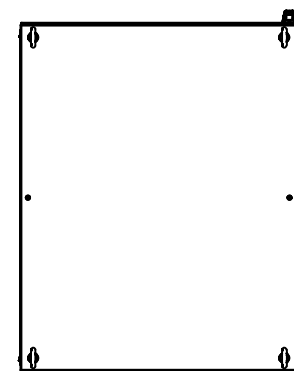

TOP

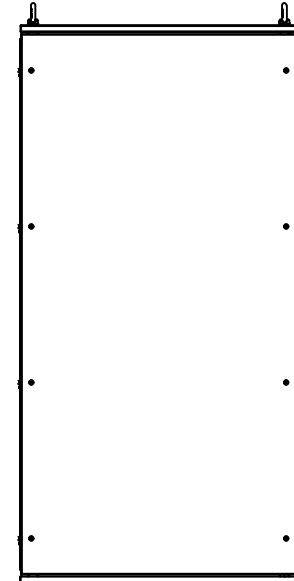

BACK

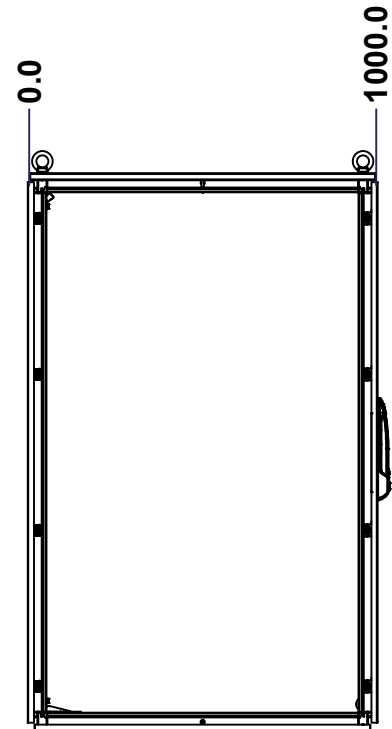

LEFT

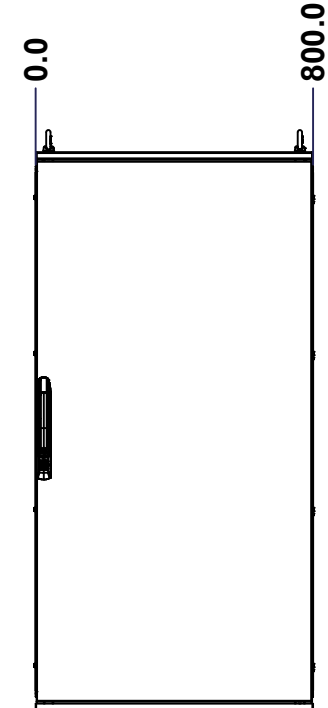

FRONT

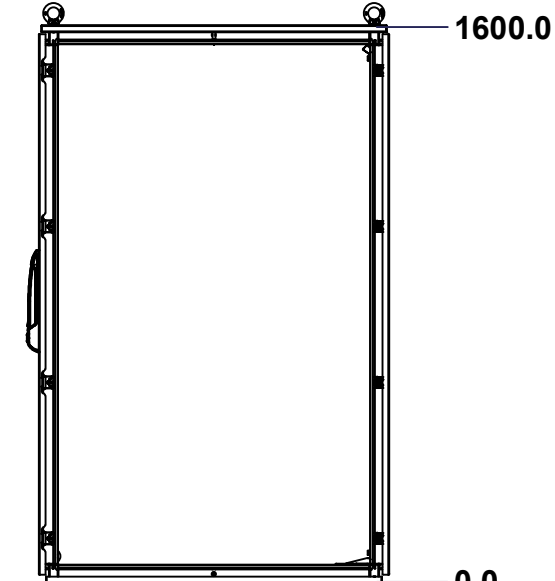

RIGHT

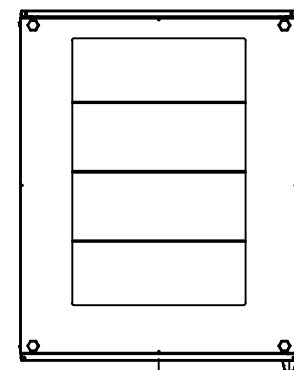

BOTTOM

No.	Revisions	Date	By/Par

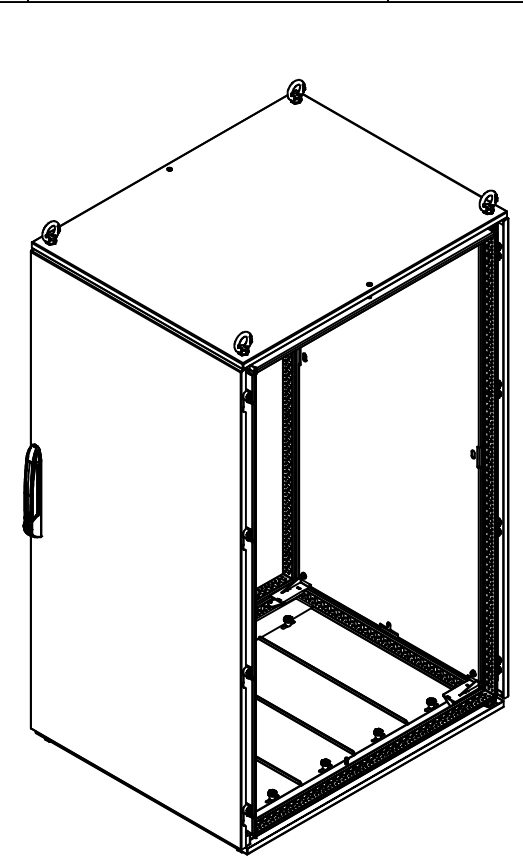

Isometric View



Tél: (450) 979-4373  
 Fax: (450) 979-4626  
[www.exmweb.com](http://www.exmweb.com)

Flatness  
Aplatissement  
Max 3.0mm  
Projection

Customer Client	Date
Drawn By Dessiné Par BoxCad: BoxCad	Date 04-Feb-15

Material  
Matière See Part List

Color Couleur See Part List	Finish Fini See Part List
--------------------------------	------------------------------

Description  
6500MX 1600mm x 800mm x 1000mm  
Assembly

Part Number Numéro Pièce	Rev.	1
<b>6500MXK160810</b>	<b>0</b>	18

SEE BILL OF MATERIAL ON LAST PAGE

This drawing is confidential and must not be reproduced or used without the consent of EXM

Ce dessin est confidentiel et ne doit pas être reproduit ou utilisé sans le consentement de EXM

No.	Revisions	Date	By/Par

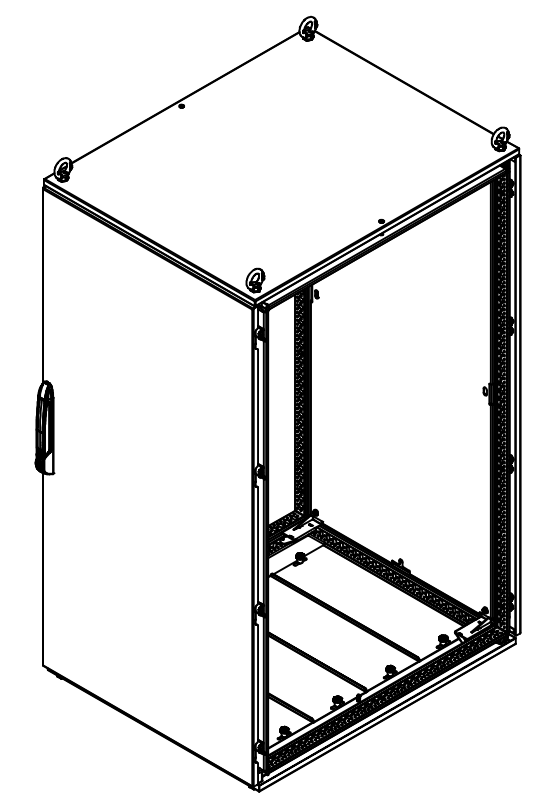

Isometric View



Tél: (450) 979-4373  
 Fax: (450) 979-4626  
[www.exmweb.com](http://www.exmweb.com)

Flatness  
Aplatissement  
Max 3.0mm  
Projection

Customer Client	Date
Drawn By / Dessiné Par: BoxCad: BoxCad	Date: 04-Feb-15
Material / Matière: See Part List	

Qty	Part Number	Rev	Description
1	6500MXK160810BIP	0	6500 MXM 1600mm x 800mm Back Inner Panel
1	6500MXK160810F	0	6500 MXD 1600mm x 800mm Front
1	6500MXK160810B	0	6500 MXR 1600mm x 800mm Back
1	6500MXK160810BT	0	6500 MXB 800mm x 1000mm Bottom
1	6500MXK160810T	0	6500 MXT 800mm x 1000mm Top
1	6500MXK160810FR	0	6500 MX 1600mm x 800mm x 1000mm Frame
Parts List			

Color / Couleur: See Part List	Finish / Fini: See Part List
Description: 6500MX 1600mm x 800mm x 1000mm Assembly	
Part Number / Numéro Pièce: <b>6500MXK160810</b>	Rev. / Révis: 0
2 / 18	

This drawing is confidential and must not be reproduced or used without the consent of EXM

Ce dessin est confidentiel et ne doit pas être reproduit ou utilisé sans le consentement de EXM

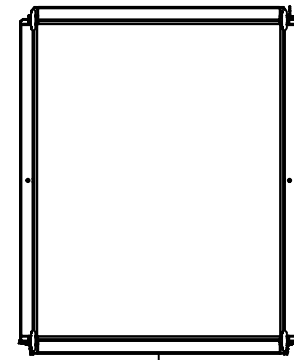

TOP

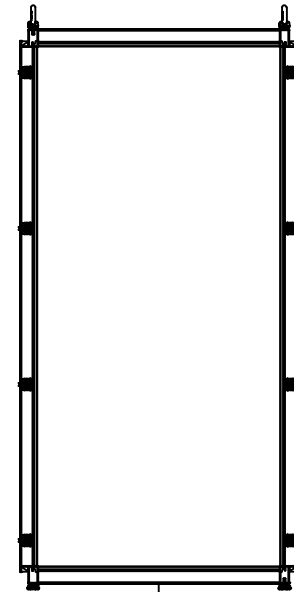

BACK

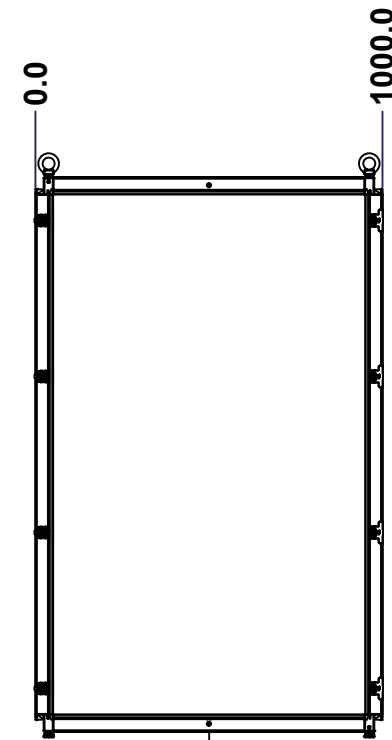

LEFT

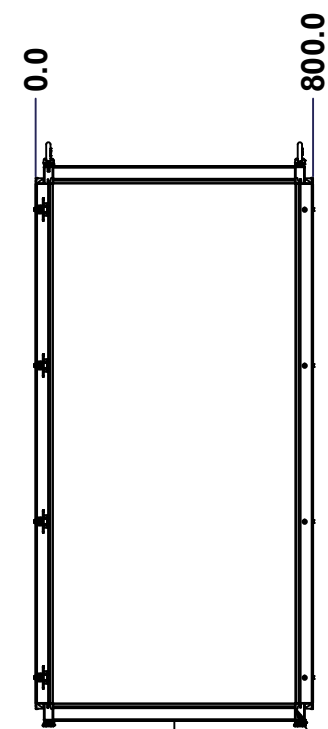

FRONT

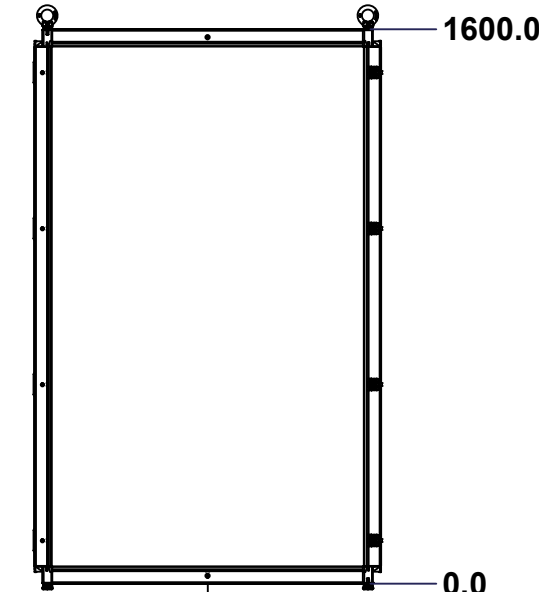

RIGHT

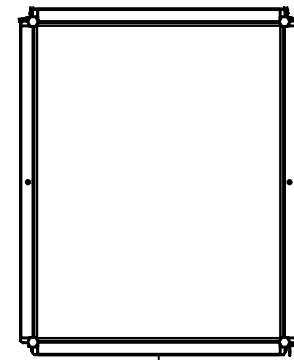

BOTTOM

Grind excess weld off corner(s)

No.	Revisions	Date	By/Par

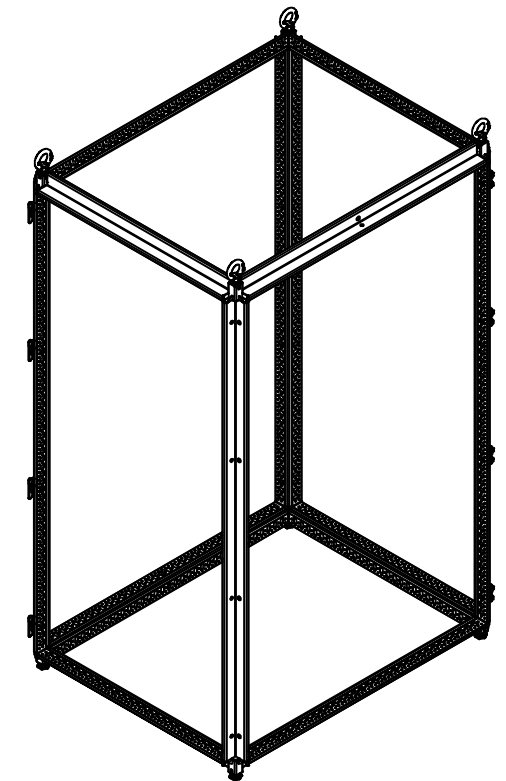

Isometric View

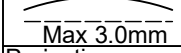
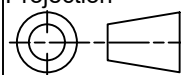

 Tél: (450) 979-4373 Fax: (450) 979-4626 <a href="http://www.exmweb.com">www.exmweb.com</a>		Flatness Aplatissement  Max 3.0mm Projection 
Customer Client		Date
Drawn By Dessiné Par	BoxCad: BoxCad	Date 04-Feb-15
Material Matière	16 Ga Electro-Galvanized (1.4mm)	
Color Couleur	Iron Grey RAL7011	Finish Fini Textured
Description 6500 MX 1600mm x 800mm x 1000mm Frame		Detail Rev.
Part Number Numéro Pièce	<b>6500MXK160810FR</b>	Rev. 3 <b>0</b>

SEE BILL OF MATERIAL ON LAST PAGE

This drawing is confidential and must not be reproduced or used without the consent of EXM

Ce dessin est confidentiel et ne doit pas être reproduit ou utilisé sans le consentement de EXM

No.	Revisions	Date	By/Par

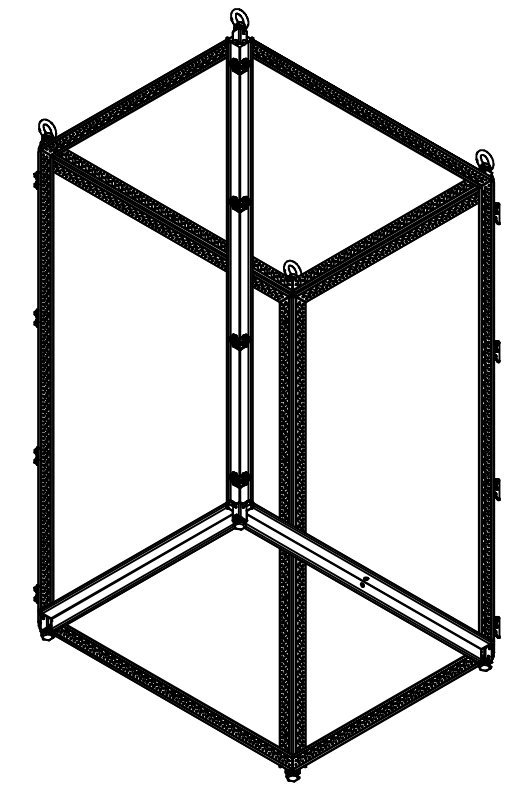

Isometric View



Qty	Part Number	Rev	Description
1	STK-P-03810ST	0	Powder Paint (Iron Grey /Sand Textured)
4	STK-Q-47250-08	6	6500 MX 800mm Horizontal Frame Post Part
4	STK-Q-47250-10	6	6500 MX 1000mm Horizontal Frame Post Part
4	STK-A-70589	9	6500 MX Fixed Side Panel Bracket Assembly
22	STK-Q-77120	1	6500MX-Frame Rubber Plug
8	STK-A-70580	9	Mtrx Bracket
8	STK-Q-00610	3	M16 x 30.0mm Bolt
8	STK-A-49448	6	6500 MX - Frame Sheet Metal Corner Assembly
4	STK-Q-49500	3	M12 Eye Bolt (0.34T)
4	STK-Q-61110	0	M12 Feet Leveler
4	STK-Q-47251-16	6	6500 MX 1600mm Vertical Frame Post Part
Parts List			

Tél: (450) 979-4373 Fax: (450) 979-4626 <a href="http://www.exmweb.com">www.exmweb.com</a>		Flatness Aplatissement Max 3.0mm Projection 
Customer Client	Date	
Drawn By Dessiné Par	BoxCad: BoxCad	Date 04-Feb-15
Material Matière	16 Ga Electro-Galvanized (1.4mm)	
Color Couleur	Iron Grey RAL7011	Finish Fini Textured
Description	Detail Rev.	
6500 MX 1600mm x 800mm x 1000mm Frame		
Part Number Numéro Pièce	Rev.	4
<b>6500MXK160810FR</b>	<b>0</b>	18

This drawing is confidential and must not be reproduced or used without the consent of EXM

Ce dessin est confidentiel et ne doit pas être reproduit ou utilisé sans le consentement de EXM



TOP

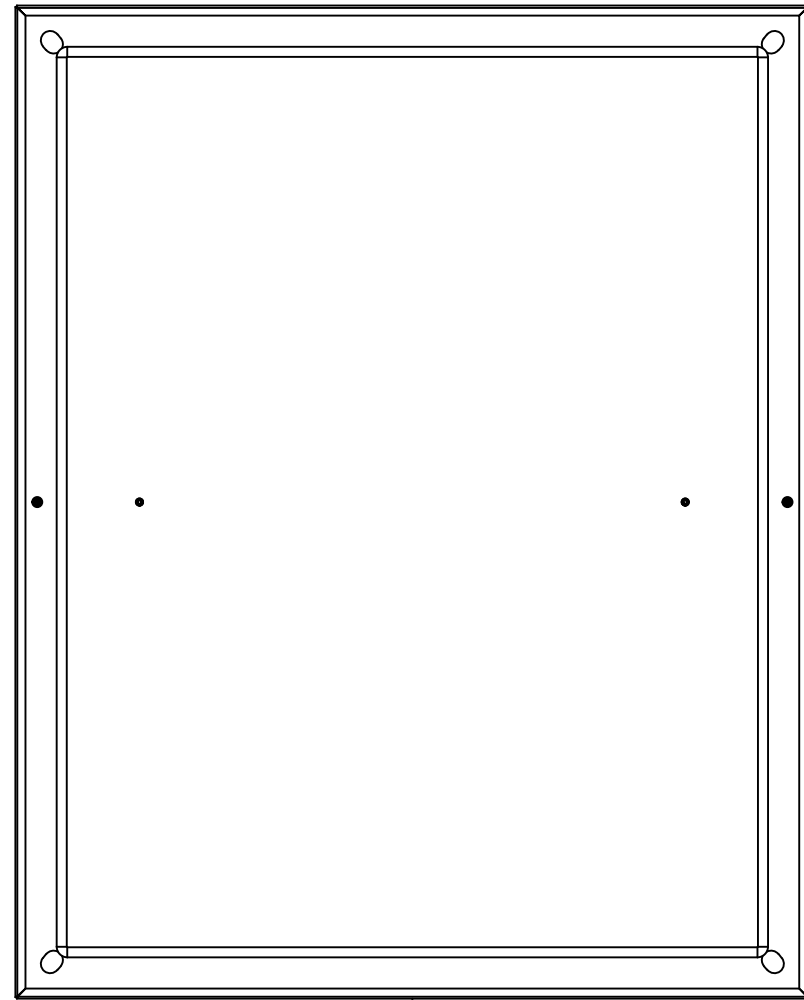

BACK



BOTTOM

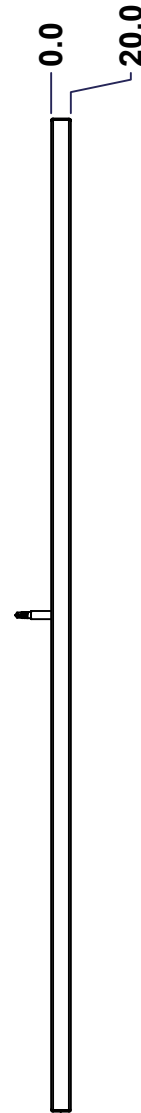

LEFT

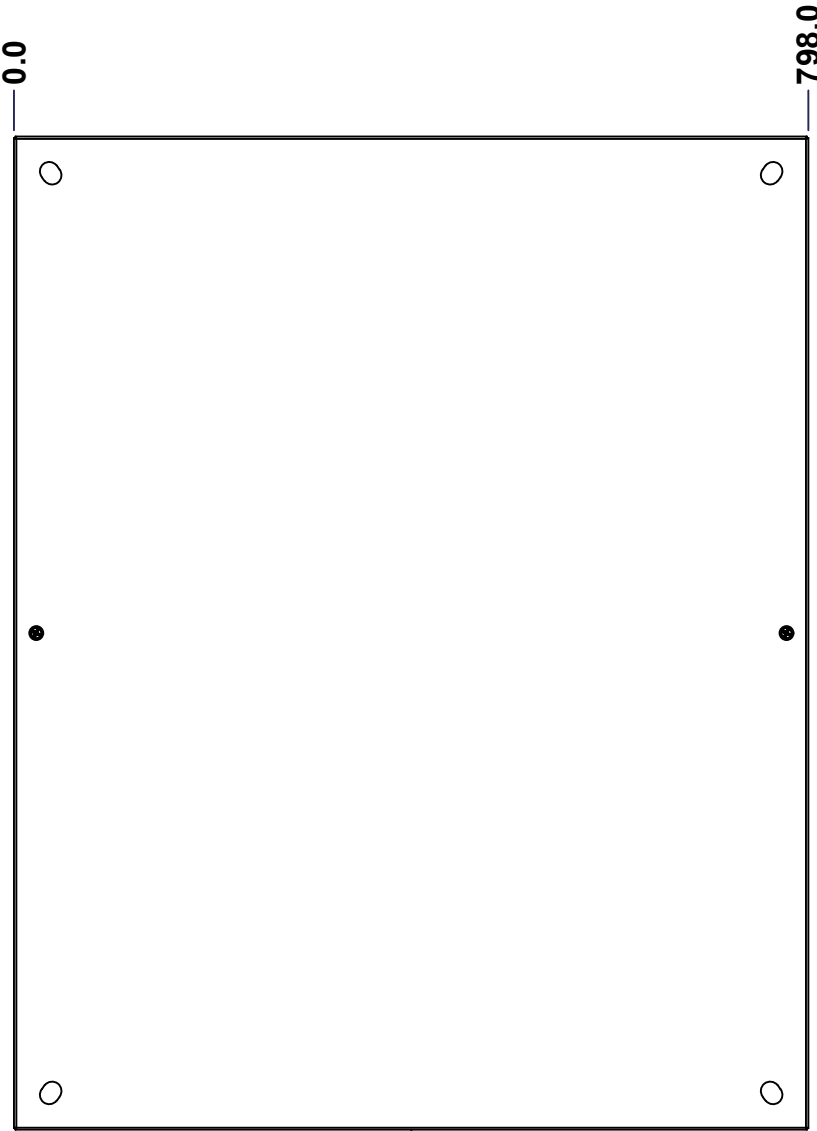

FRONT

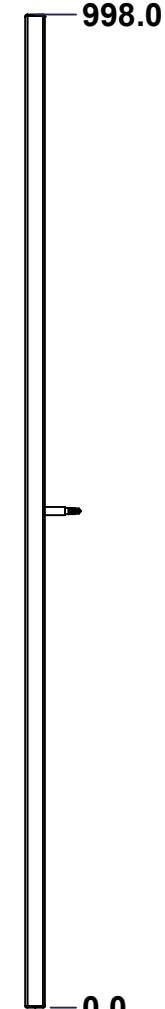

RIGHT

No.	Revisions	Date	By/Par

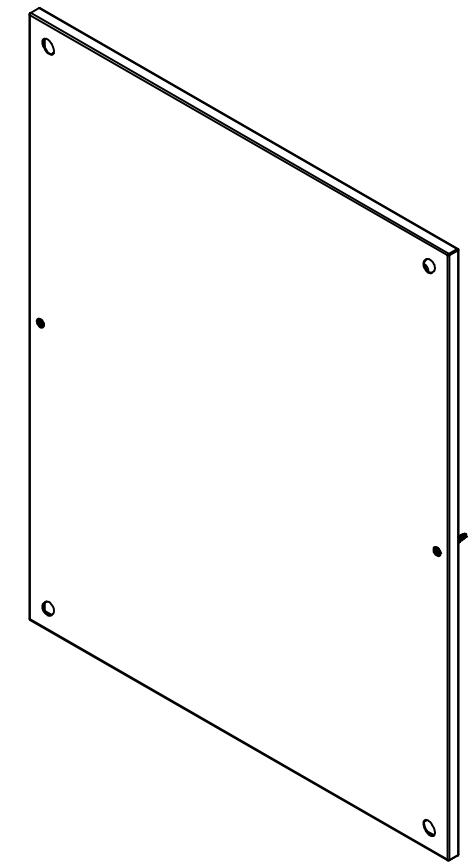

Isometric View



Tél: (450) 979-4373  
 Fax: (450) 979-4626  
[www.exmweb.com](http://www.exmweb.com)

Flatness  
 Aplatissement  
 Max 3.0mm  
 Projection

Customer Client	Date
Drawn By Dessiné Par	Date
Material Matière	04-Feb-15
16 Ga Cold Rolled A1008 CS Type B	
Color Couleur	Finish Fini
Iron Grey RAL7011	Textured
Description	Detail Rev.
6500 MXT 800mm x 1000mm Top	
Part Number Numéro Pièce	Rev.
6500MXK160810T	5
	0
	18

Use gasket program path 6500 MX > 6500 MXT

SEE BILL OF MATERIAL ON LAST PAGE

This drawing is confidential and must not be reproduced or used without the consent of EXM

Ce dessin est confidentiel et ne doit pas être reproduit ou utilisé sans le consentement de EXM

STANDARD FEATURES ARE NOT LISTED IN THIS HOLE TABLE			
HOLE TABLE - FRONT VIEW (CUSTOM FEATURE ONLY)			
CUT-OUT	XDIM	YDIM	DESCRIPTION
1	125.0	499.0	GND STUD M6 x 18mm (Inside)
2	673.0	499.0	GND STUD M6 x 18mm (Inside)

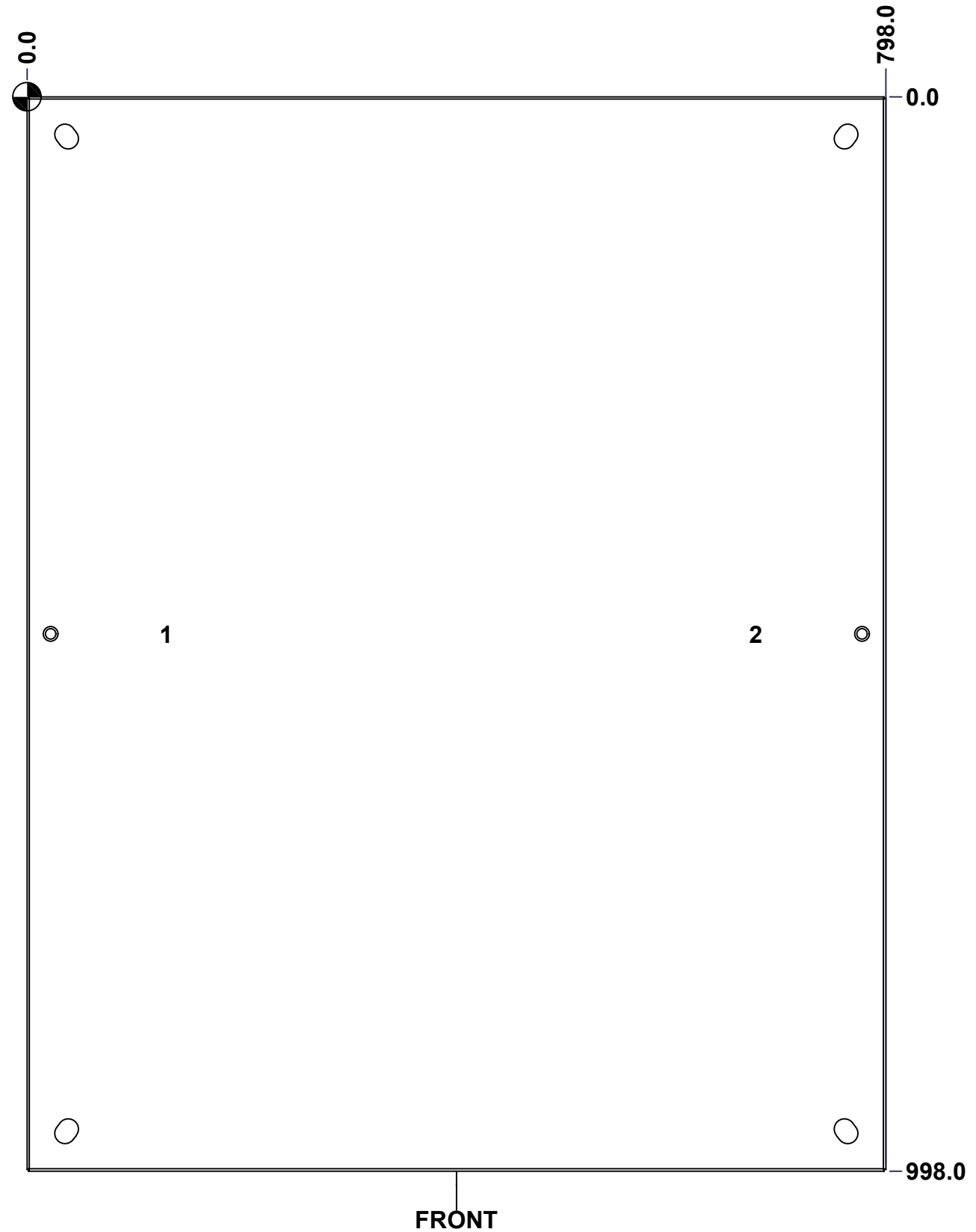

Use bending program path 6500 MX > 6500 MXT

	Description	Status
	6500 MXT 800mm x 1000mm Top	(NULL)
Part Number Numéro Pièce <b>6500MXK160810T</b>	Rev.	6
	<b>0</b>	18

This drawing is confidential and must not be reproduced or used without the consent of EXM

Ce dessin est confidentiel et ne doit pas être reproduit ou utilisé sans le consentement de EXM

No.	Revisions	Date	By/Par

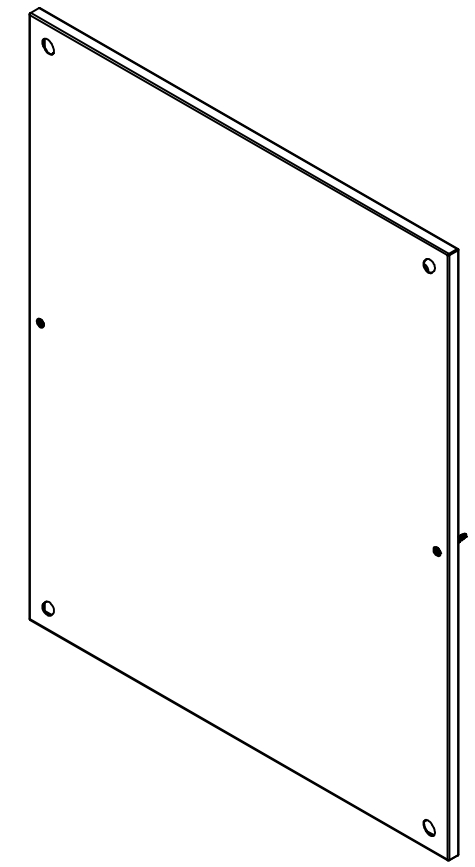

Isometric View

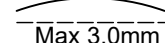
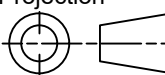

 Tél: (450) 979-4373 Fax: (450) 979-4626 <a href="http://www.exmweb.com">www.exmweb.com</a>		Flatness Aplatissement  Max 3.0mm
Customer Client Drawn By / Dessiné Par: BoxCad: BoxCad		Projection 
Date Date: 04-Feb-15		Material Matière: 16 Ga Cold Rolled A1008 CS Type B
Color Couleur: Iron Grey RAL7011	Finish Fini: Textured	
Description 6500 MXT 800mm x 1000mm Top		Detail Rev.
Part Number Numéro Pièce: <b>6500MXK160810T</b>		Rev. 7 0

Qty	Part Number	Rev	Description
1	STK-P-03810ST	0	Powder Paint (Iron Grey /Sand Textured)
2	STK-Q-16055	1	M6 x 18mm Stud (No Paint Cap Required)
2	STK-Q-90227	1	Flat Head Drilling Screw M6.3 x 56.0mm Long
1	6500MXK160810TG	0	6500 MXT 800mm x 1000mm Top Gasket
1	6500MXK160810T-P	0	6500 MXT 800mm x 1000mm Top Part
Parts List			

This drawing is confidential and must not be reproduced or used without the consent of EXM

Ce dessin est confidentiel et ne doit pas être reproduit ou utilisé sans le consentement de EXM

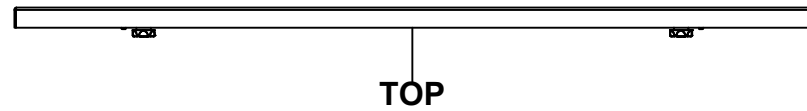

TOP

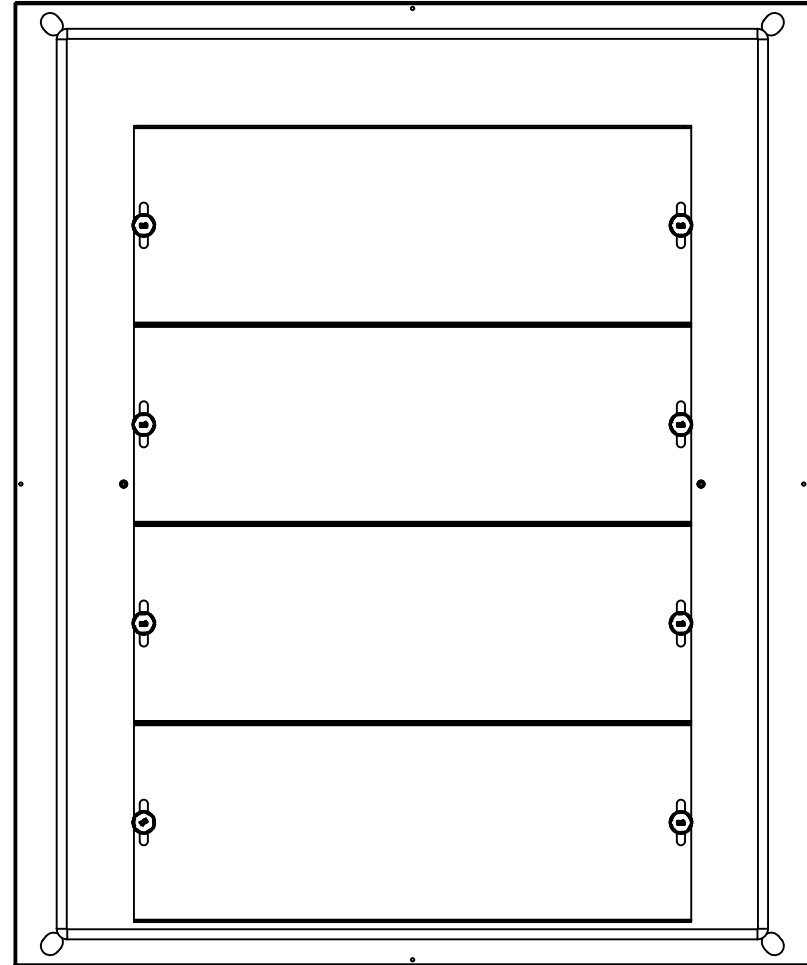

BACK

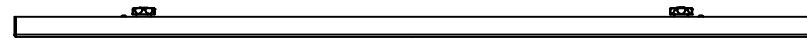

BOTTOM

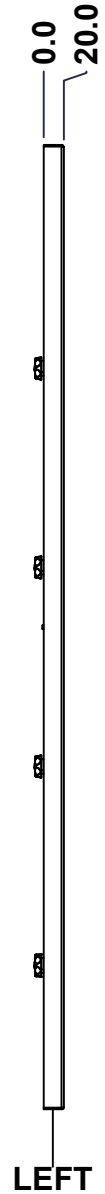

LEFT

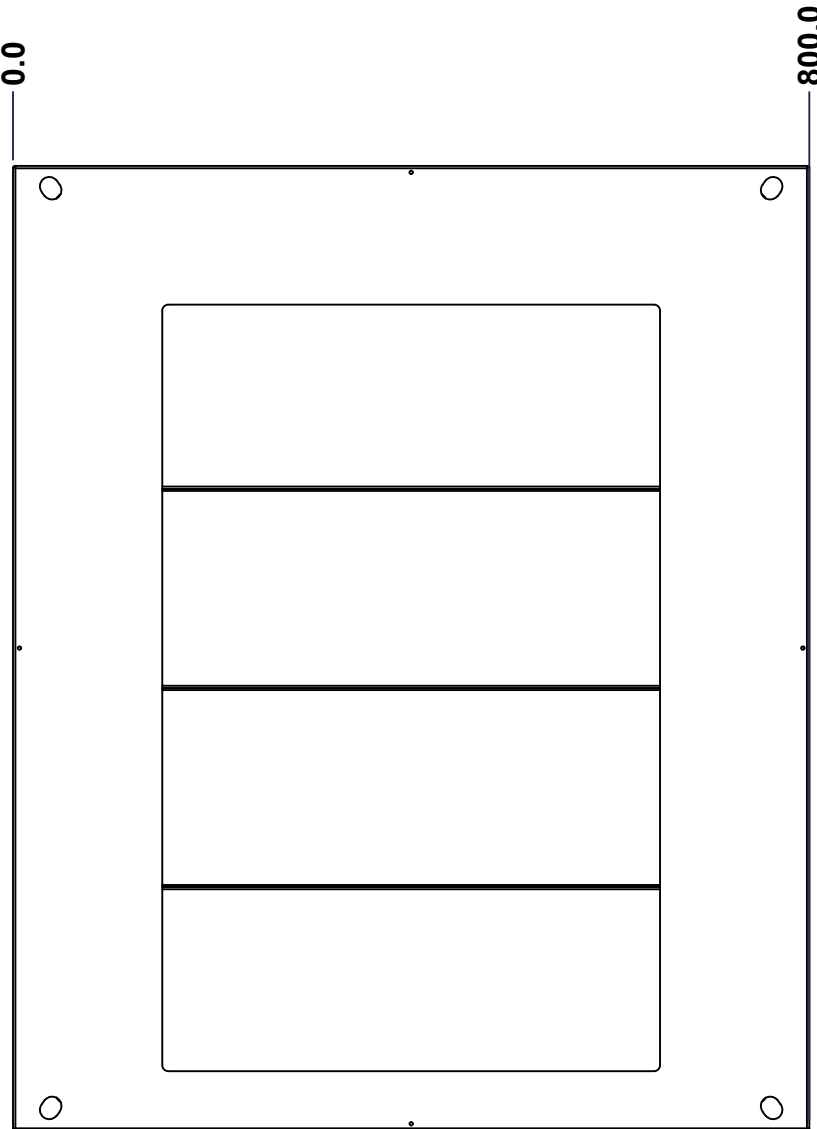

FRONT

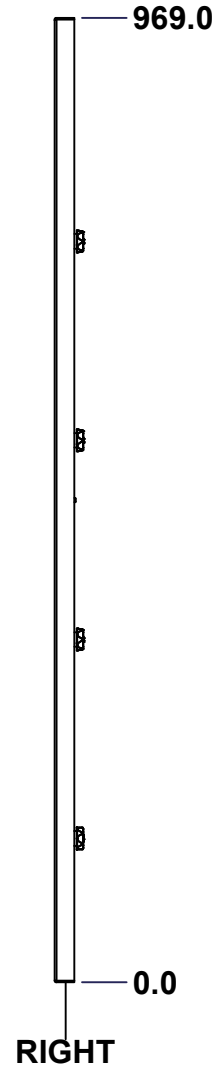

RIGHT

No.	Revisions	Date	By/Par

**Isometric View**

<p>Tél: (450) 979-4373 Fax: (450) 979-4626 <a href="http://www.exmweb.com">www.exmweb.com</a></p>		Flatness Aplatissement	
		Max 3.0mm	
Customer Client		Date	
Drawn By Dessiné Par		Date	
Material Matière		Projection	
Color Couleur		Detail Rev.	
Description		Rev.	
Part Number Numéro Pièce		8	

Use gasket program path 6500 MX > 6500MXB

SEE BILL OF MATERIAL ON LAST PAGE

**6500MXK160810BT**

This drawing is confidential and must not be reproduced or used without the consent of EXM

Ce dessin est confidentiel et ne doit pas être reproduit ou utilisé sans le consentement de EXM

**STANDARD FEATURES ARE NOT LISTED IN THIS HOLE TABLE**

**HOLE TABLE - FRONT VIEW (CUSTOM FEATURE ONLY)**

CUT-OUT	XDIM	YDIM	DESCRIPTION
1	110.0	484.5	GND STUD M6 x 18mm (Inside)
2	690.0	484.5	GND STUD M6 x 18mm (Inside)
3	130.0	744.5	GP STUD M6 x 18mm (Inside)
4	670.0	744.5	GP STUD M6 x 18mm (Inside)
5	130.0	544.5	GP STUD M6 x 18mm (Inside)
6	670.0	544.5	GP STUD M6 x 18mm (Inside)
7	130.0	344.5	GP STUD M6 x 18mm (Inside)
8	670.0	344.5	GP STUD M6 x 18mm (Inside)
9	130.0	144.5	GP STUD M6 x 18mm (Inside)
10	670.0	144.5	GP STUD M6 x 18mm (Inside)

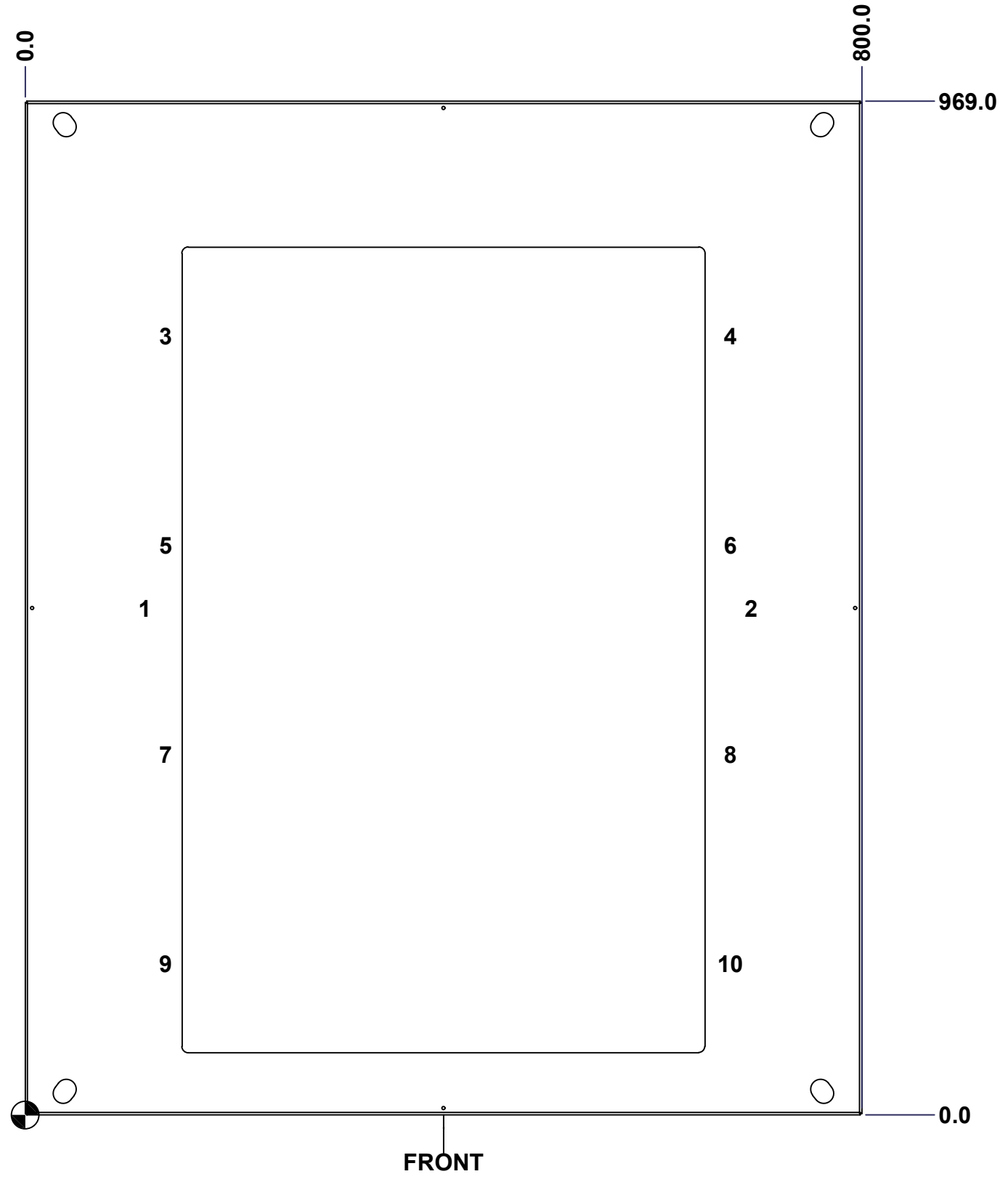

Use bending program path 6500 MX > 6500MXB

	Description	Status
	6500 MXB 800mm x 1000mm Bottom	(NULL)
	Part Number Numéro Pièce	Rev.
	<b>6500MXK160810BT</b>	<b>0</b> / 9
		18

This drawing is confidential and must not be reproduced or used without the consent of EXM

Ce dessin est confidentiel et ne doit pas être reproduit ou utilisé sans le consentement de EXM

No.	Revisions	Date	By/Par

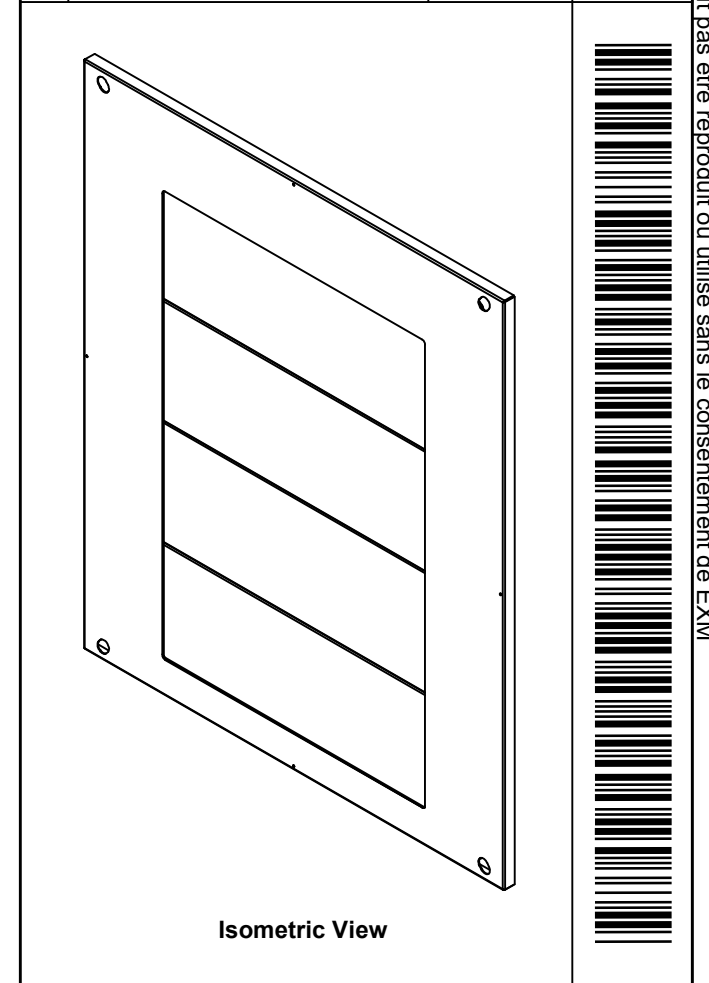

 Tél: (450) 979-4373  
 Fax: (450) 979-4626  
[www.exmweb.com](http://www.exmweb.com)

**Flatness**  
 Aplatissement  
 Max 3.0mm  
**Projection**  

Customer Client	Date
Drawn By / Dessiné Par: BoxCad: BoxCad	Date: 04-Feb-15

Material / Matière: 16 Ga Cold Rolled A1008 CS Type B

Color / Couleur: Iron Grey RAL7011	Finish / Fini: Textured
------------------------------------	-------------------------

Description: 6500 MXB 800mm x 1000mm Bottom	Detail Rev.
---	-------------

Part Number / Numéro Pièce: <b>6500MXK160810BT</b>	Rev. / Révis: <b>0</b>	10
		18

Qty	Part Number	Rev	Description
1	STK-P-03810ST	0	Powder Paint (Iron Grey /Sand Textured)
8	STK-Q-06001	0	Mtrx - Gland Plate M6 Plastic Thumb Nut
10	STK-Q-16055	1	M6 x 18mm Stud (No Paint Cap Required)
4	6500MXK160810GP200-P	0	6500 MXB 800mm Gland Plate Part (200mm)
1	6500MXK160810BTGPG	0	6500 MXB 800mm x 1000mm Bottom Gland Plate Gasket
1	6500MXK160810BTG	0	6500 MXB 800mm x 1000mm Bottom Gasket
1	6500MXK160810BT-P	0	6500 MXB 800mm x 1000mm Bottom Part
Parts List			

This drawing is confidential and must not be reproduced or used without the consent of EXM

Ce dessin est confidentiel et ne doit pas être reproduit ou utilisé sans le consentement de EXM

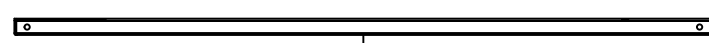
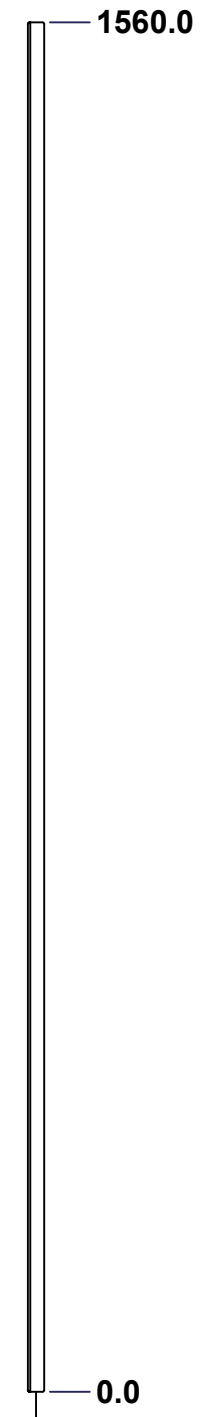
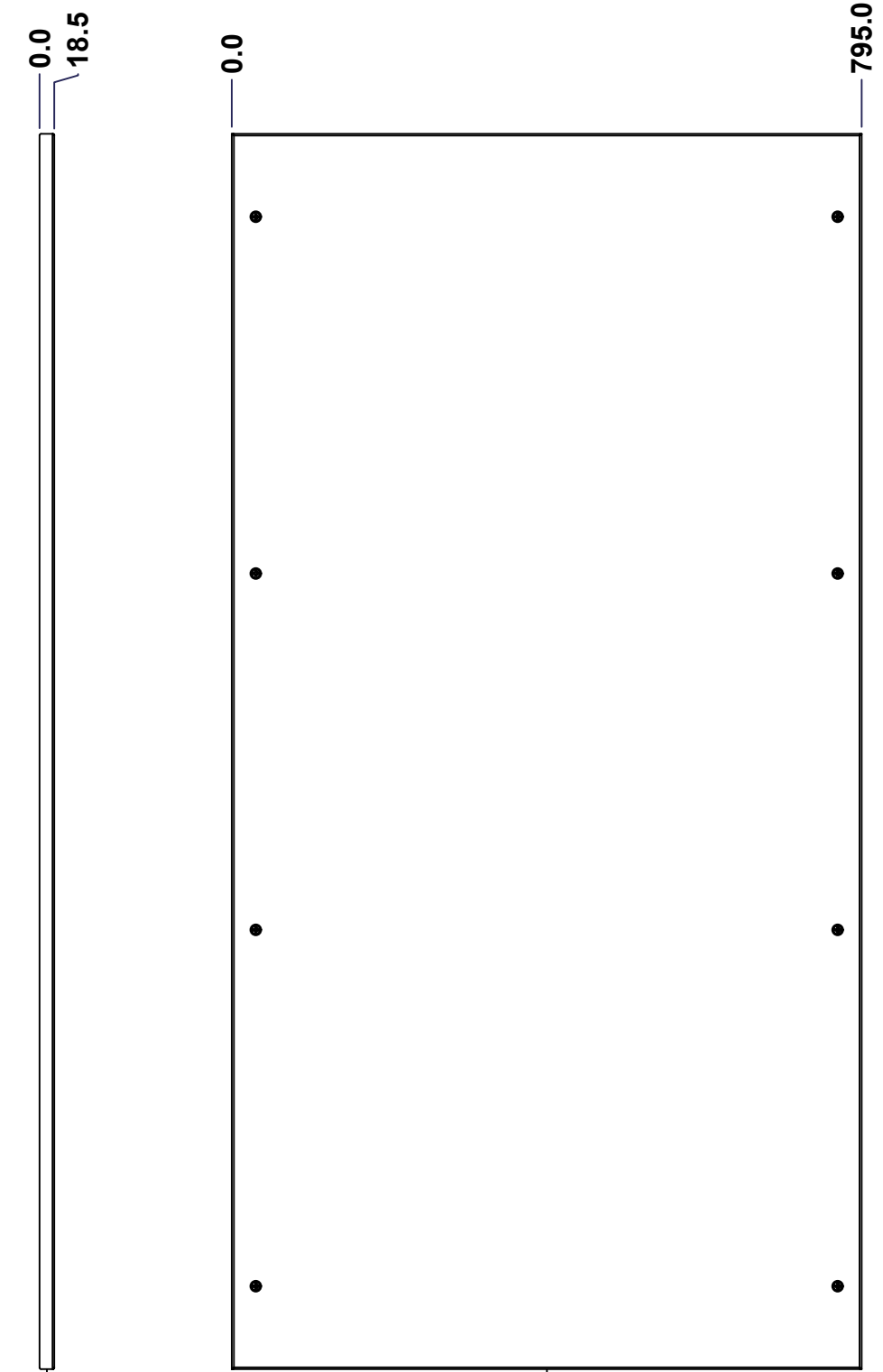
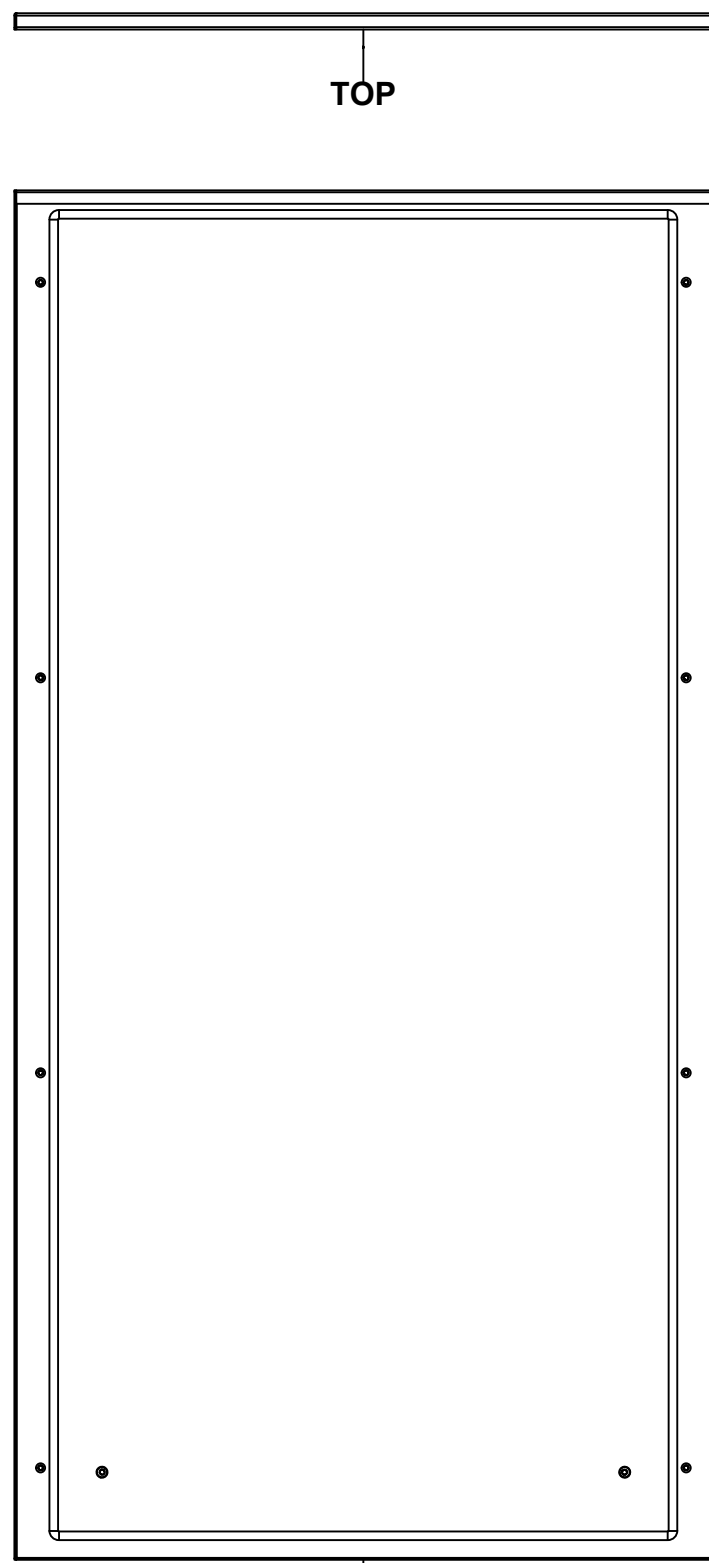

No.	Revisions	Date	By/Par

**Isometric View**

<p>Tél: (450) 979-4373 Fax: (450) 979-4626 <a href="http://www.exmweb.com">www.exmweb.com</a></p>		Flatness Aplatissement
		Max 3.0mm
Projection		
Customer Client	Date	
Drawn By Dessiné Par	BoxCad: BoxCad	Date 04-Feb-15
Material Matière	14 Ga Cold Rolled A1008 CS Type B	
Color Couleur	Light Grey RAL7035	Finish Fini Textured
Description	Detail Rev.	
6500 MXR 1600mm x 800mm Back		
Part Number Numéro Pièce	Rev.	11
<b>6500MXK160810B</b>	<b>0</b>	18

Use gasket program path 6500 MX > 6500 MXR

SEE BILL OF MATERIAL ON LAST PAGE

This drawing is confidential and must not be reproduced or used without the consent of EXM

Ce dessin est confidentiel et ne doit pas être reproduit ou utilisé sans le consentement de EXM

STANDARD FEATURES ARE NOT LISTED IN THIS HOLE TABLE			
HOLE TABLE - FRONT VIEW (CUSTOM FEATURE ONLY)			
CUT-OUT	XDIM	YDIM	DESCRIPTION
1	100.0	100.0	GND STUD M6 x 16mm (Inside)
2	695.0	100.0	GND STUD M6 x 16mm (Inside)

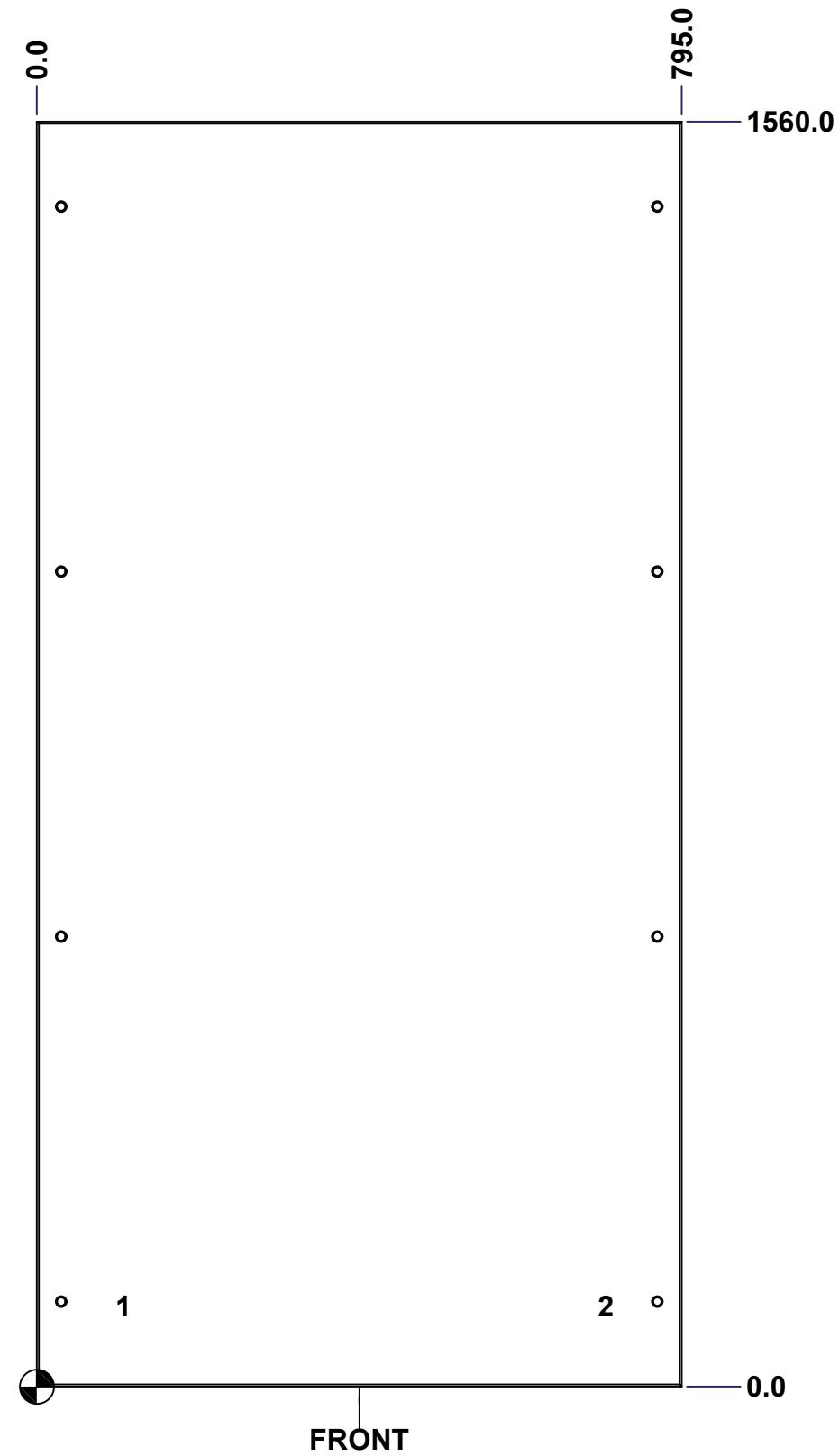

Use bending program path 6500 MX > 6500 MXR

	Description	Status
	6500 MXR 1600mm x 800mm Back	(NULL)
	Part Number Numéro Pièce	Rev.
	<b>6500MXK160810B</b>	<b>0</b>
		12
		18

This drawing is confidential and must not be reproduced or used without the consent of EXM

Ce dessin est confidentiel et ne doit pas être reproduit ou utilisé sans le consentement de EXM

No.	Revisions	Date	By/Par

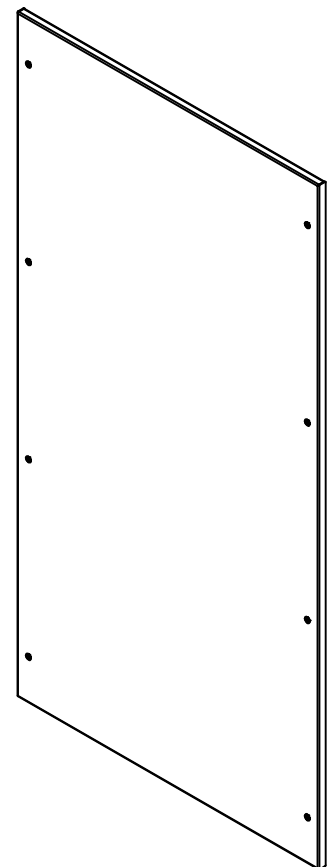

**Isometric View**

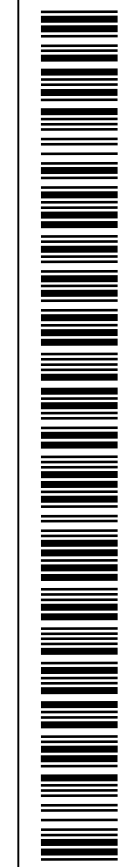

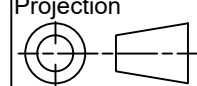
		Flatness Aplatissement Max 3.0mm	
Tél: (450) 979-4373 Fax: (450) 979-4626 <a href="http://www.exmweb.com">www.exmweb.com</a>		Projection 	
Customer Client		Date	
Drawn By / Dessiné Par: BoxCad: BoxCad		Date: 04-Feb-15	
Material / Matière: 14 Ga Cold Rolled A1008 CS Type B			
Color / Couleur: Light Grey RAL7035		Finish / Fini: Textured	
Description: 6500 MXR 1600mm x 800mm Back			Detail Rev.
Part Number / Numéro Pièce: <b>6500MXK160810B</b>			Rev. 13
			18

Qty	Part Number	Rev	Description
1	STK-P-03820R	0	Powder Paint (Light Grey / Rough Textured)
1	6500MXK160810BG	0	6500 MXR 1600mm x 800mm Back Gasket
8	STK-Q-03071	0	M6 x 16mm Machine Screw
2	STK-Q-16080	0	Ground Stud M6 x 16mm Steel
1	6500MXK160810B-P	0	6500 MXR 1600mm x 800mm Back Part
Parts List			

This drawing is confidential and must not be reproduced or used without the consent of EXM

Ce dessin est confidentiel et ne doit pas être reproduit ou utilisé sans le consentement de EXM

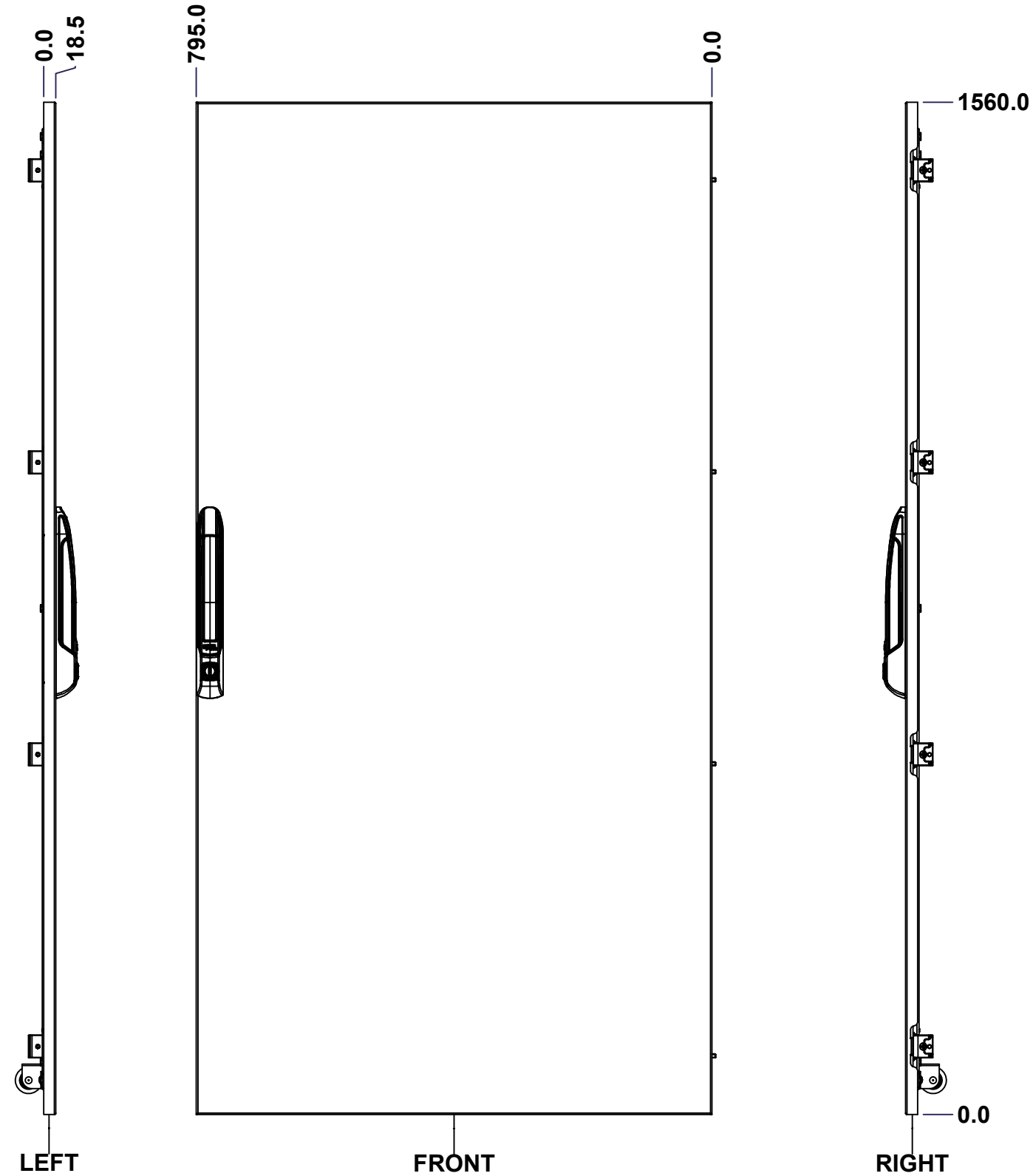
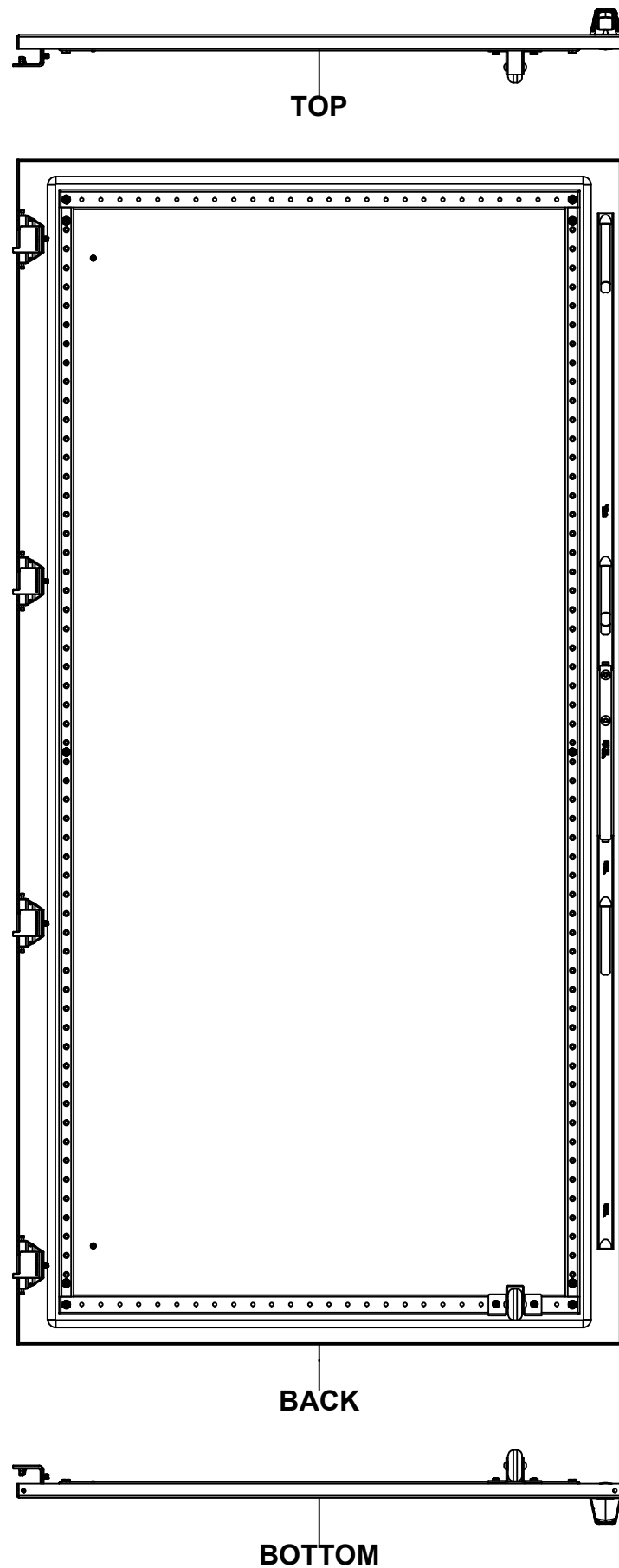

No.	Revisions	Date	By/Par

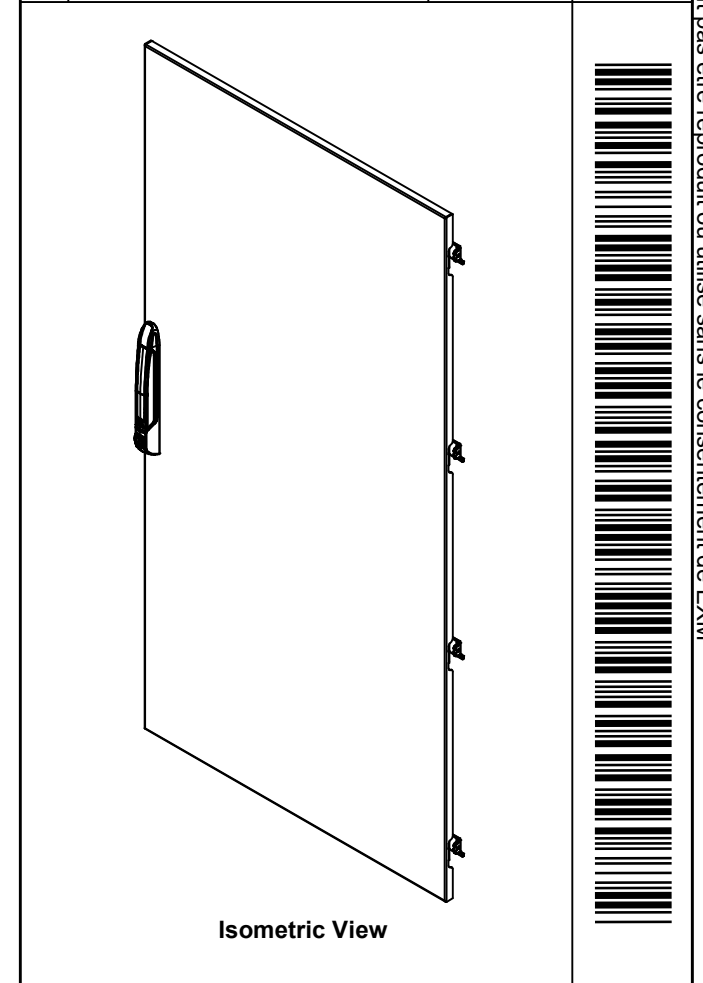

Isometric View

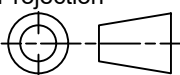
 Tél: (450) 979-4373 Fax: (450) 979-4626 <a href="http://www.exmweb.com">www.exmweb.com</a>		Flatness Aplatissement Max 3.0mm Projection 
Customer Client	Date	
Drawn By Dessiné Par	BoxCad: BoxCad	Date 04-Feb-15
Material Matière	14 Ga Cold Rolled A1008 CS Type B	
Color Couleur	Light Grey RAL7035	Finish Fini Textured
Description	Detail Rev.	
6500 MXD 1600mm x 800mm Front		
Part Number Numéro Pièce	Rev.	14
<b>6500MXK160810F</b>	<b>0</b>	18

Use gasket program path 6500 MX > 6500 MXD

SEE BILL OF MATERIAL ON LAST PAGE

This drawing is confidential and must not be reproduced or used without the consent of EXM

Ce dessin est confidentiel et ne doit pas être reproduit ou utilisé sans le consentement de EXM

**STANDARD FEATURES ARE NOT LISTED IN THIS HOLE TABLE**

**HOLE TABLE - FRONT VIEW (CUSTOM FEATURE ONLY)**

CUT-OUT	XDIM	YDIM	DESCRIPTION
1	100.0	130.0	GND STUD M6 x 16mm (Inside)
2	100.0	1430.0	GND STUD M6 x 16mm (Inside)
3	64.5	52.8	STIFF. STUD M6 x 18mm (Inside)
4	64.5	1507.2	STIFF. STUD M6 x 18mm (Inside)
5	730.5	52.8	STIFF. STUD M6 x 18mm (Inside)
6	730.5	1507.2	STIFF. STUD M6 x 18mm (Inside)
7	64.5	780.0	STIFF. STUD M6 x 18mm (Inside)
8	730.5	780.0	STIFF. STUD M6 x 18mm (Inside)
9	730.5	1479.0	STIFF. STUD M6 x 18mm (Inside)
10	730.5	81.0	STIFF. STUD M6 x 18mm (Inside)
11	64.5	1479.0	STIFF. STUD M6 x 18mm (Inside)
12	64.5	81.0	STIFF. STUD M6 x 18mm (Inside)
13	774.0	170.0	LARGE CBAR GUIDE (Inside)
14	774.0	1390.0	LARGE CBAR GUIDE (Inside)
15	774.0	605.0	LARGE CBAR GUIDE (Inside)
16	774.0	955.0	LARGE CBAR GUIDE (Inside)

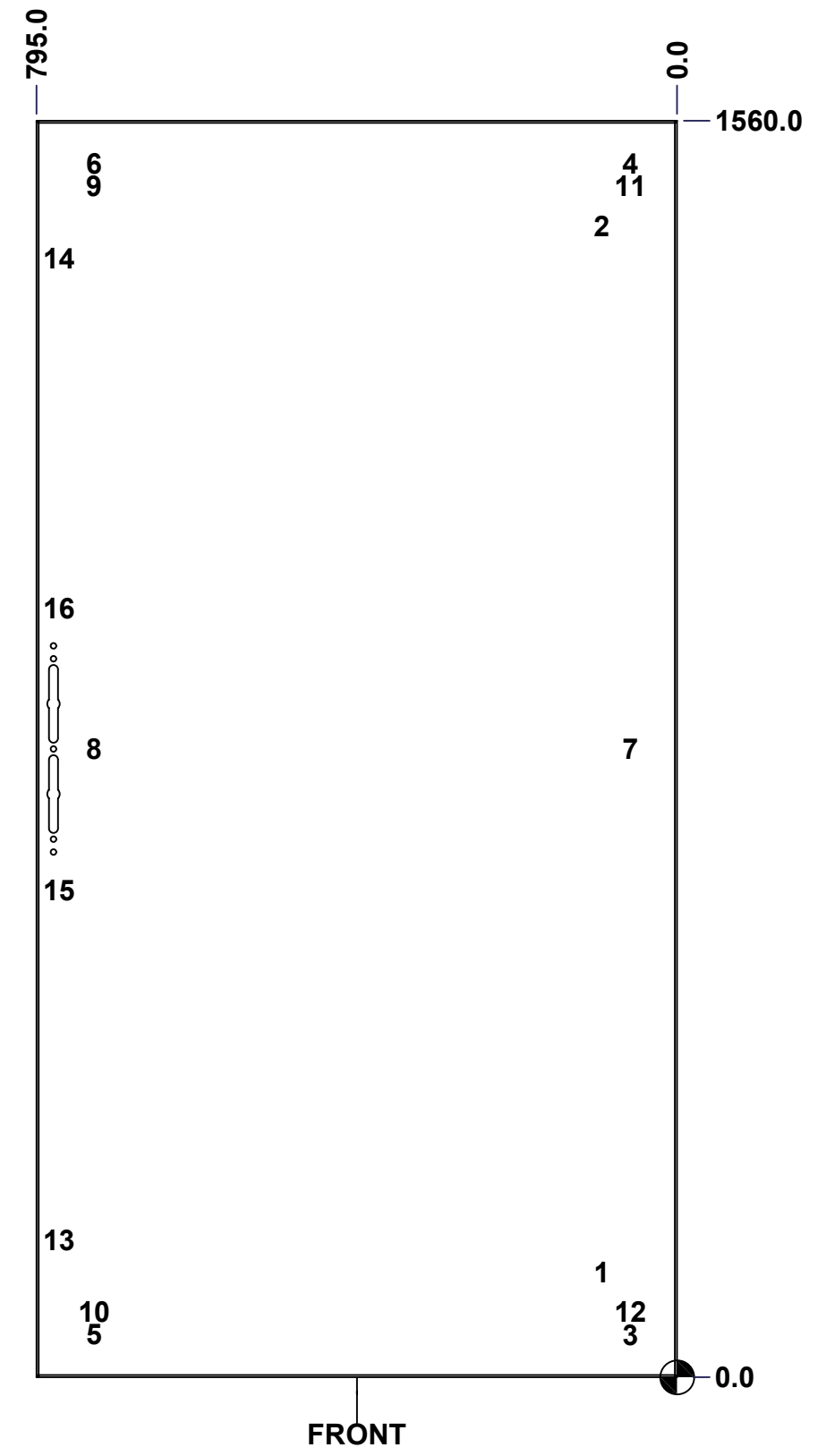

FRONT

Use bending program path 6500 MX > 6500 MXD

	Description 6500 MXD 1600mm x 800mm Front	Status (NULL)
	Part Number Numéro Pièce <b>6500MXK160810F</b>	Rev. 15 <b>0</b>

This drawing is confidential and must not be reproduced or used without the consent of EXM

Ce dessin est confidentiel et ne doit pas être reproduit ou utilisé sans le consentement de EXM

No.	Revisions	Date	By/Par

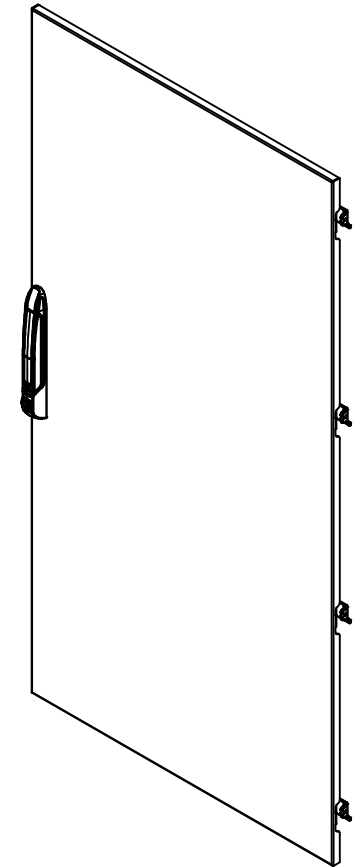

Isometric View



Qty	Part Number	Rev	Description
1	STK-P-03820R	0	Powder Paint (Light Grey / Rough Textured)
1	STK-A-45758	4	886 PH2 Pull Handle Bridge - Assembly
1	STK-A-51160	0	886PH2-SL - Pull Handle Lock - Assembly
1	STK-Q-45662-16	1	6500 MX - Lower Closing Bar 1600mm
1	STK-Q-45661-16	1	6500 MX - Upper Closing Bar 1600mm
1	6500MXSRK	1	6500 MXRSK Door Support Roller
4	STK-Q-16410	0	Guide Stud - Large (No Paint Cap Required)
4	STK-K-06810	7	6500 MX Hinge Assy
12	STK-Q-16055	1	M6 x 18mm Stud (No Paint Cap Required)
1	6500MXK160810DS1	5	6500 MX 1600mm x 800mm Door Stiffener
1	6500MXK160810FG	0	6500 MXD 1600mm x 800mm Front Gasket
1	6500MXK160810F-P	0	6500 MXD 1600mm x 800mm Front Part

Tél: (450) 979-4373 Fax: (450) 979-4626 <a href="http://www.exmweb.com">www.exmweb.com</a>		Flatness Aplatissement Max 3.0mm Projection 
Customer Client	Date	Date 04-Feb-15
Drawn By Dessiné Par	BoxCad: BoxCad	
Material Matière	14 Ga Cold Rolled A1008 CS Type B	
Color Couleur	Light Grey RAL7035	Finish Fini Textured
Description	6500 MXD 1600mm x 800mm Front	
Part Number Numéro Pièce	Rev. 0	16 / 18

Parts List

**6500MXK160810F**

This drawing is confidential and must not be reproduced or used without the consent of EXM

Ce dessin est confidentiel et ne doit pas être reproduit ou utilisé sans le consentement de EXM



TOP

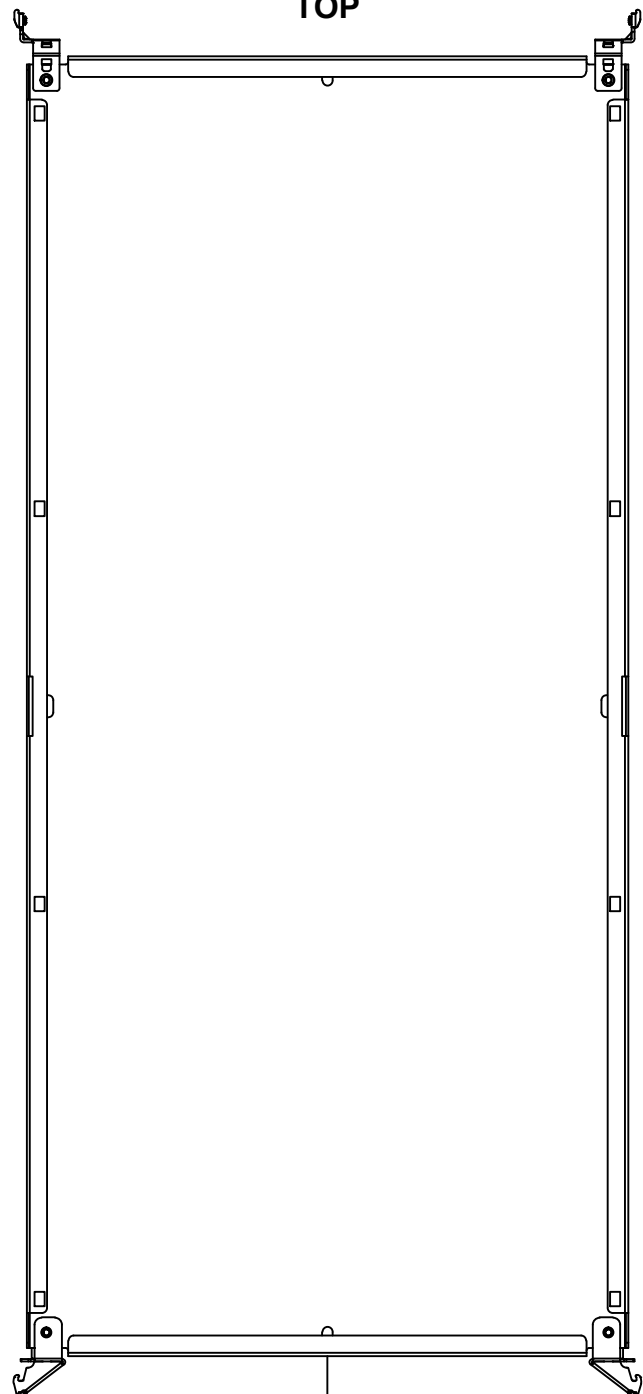

BACK

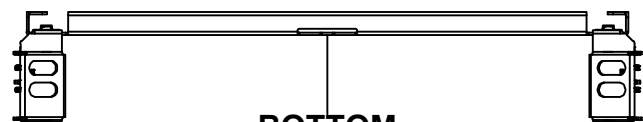

BOTTOM

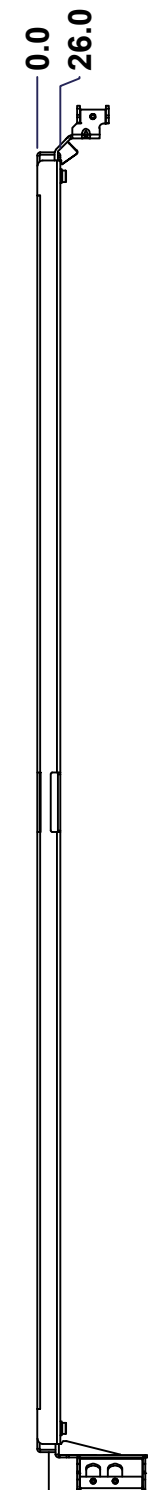

LEFT

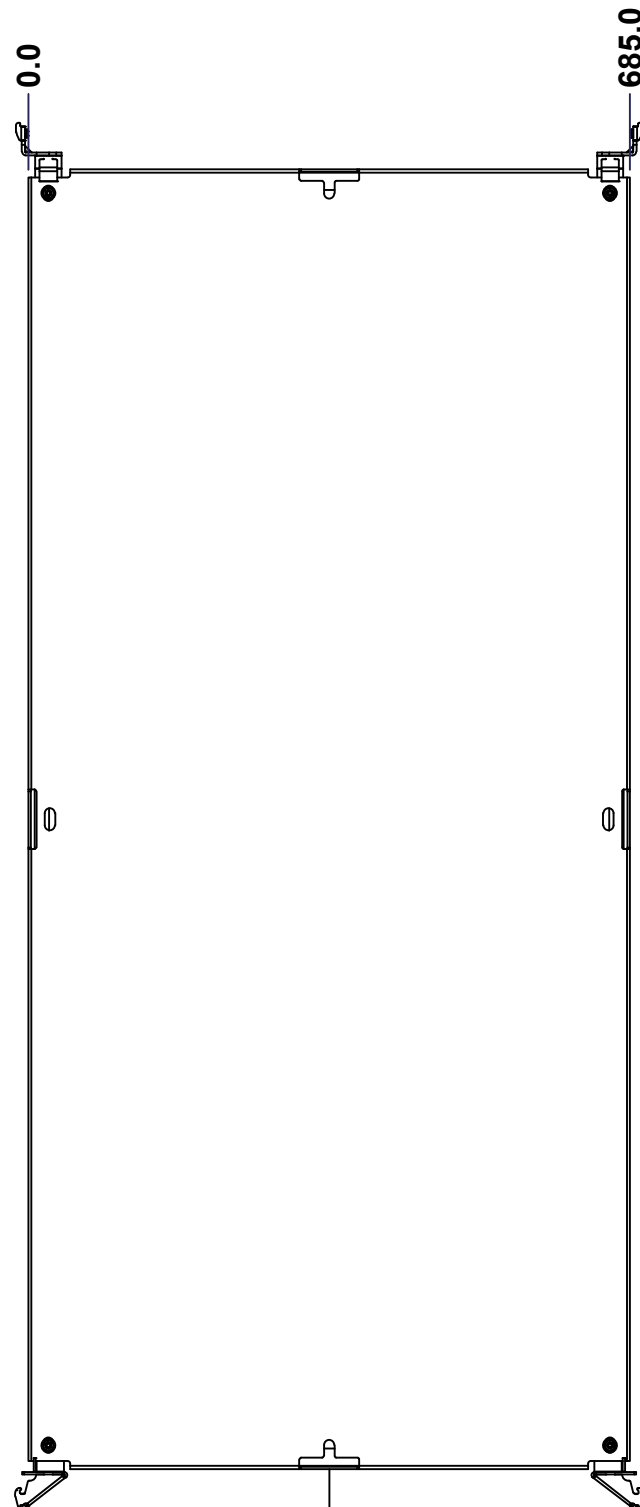

FRONT

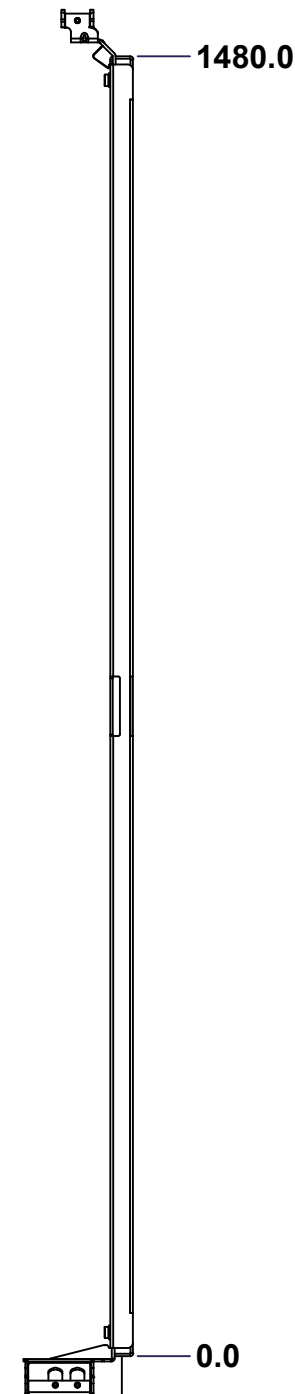

RIGHT

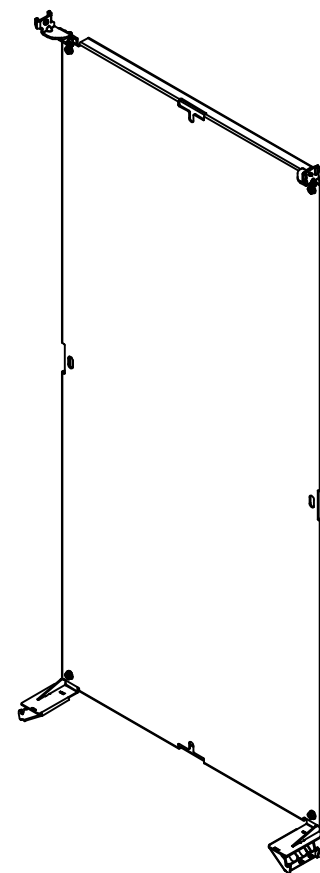

Isometric View



No.	Revisions	Date	By/Par

 Tél: (450) 979-4373 Fax: (450) 979-4626 <a href="http://www.exmweb.com">www.exmweb.com</a>		Flatness Aplatissement  Max 3.0mm
Customer Client Drawn By / Dessiné Par: BoxCad: BoxCad Material / Matière: 12 Ga Galvanized (2.5mm)		Projection  Date: 04-Feb-15
Color / Couleur: Unpainted Finish / Fini: Unpainted		Description: 6500 MXM 1600mm x 800mm Back Inner Panel Detail Rev.
Part Number / Numéro Pièce: <b>6500MXK160810BIP</b>		Rev. 17 0

SEE BILL OF MATERIAL ON LAST PAGE

This drawing is confidential and must not be reproduced or used without the consent of EXM

Ce dessin est confidentiel et ne doit pas être reproduit ou utilisé sans le consentement de EXM

No.	Revisions	Date	By/Par

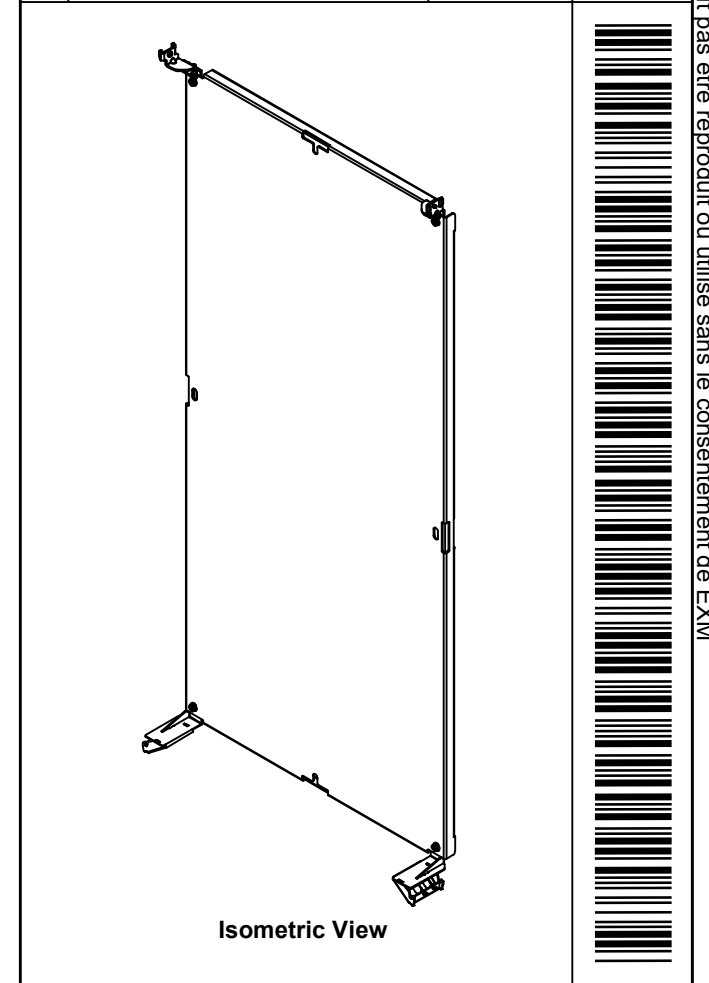

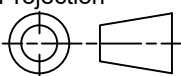
 Tél: (450) 979-4373 Fax: (450) 979-4626 <a href="http://www.exmweb.com">www.exmweb.com</a>		Flatness Aplatissement Max 3.0mm Projection 
Customer Client	Date	
Drawn By Dessiné Par	BoxCad: BoxCad	Date 04-Feb-15
Material Matière	12 Ga Galvanized (2.5mm)	
Color Couleur	Unpainted	Finish Fini Unpainted
Description 6500 MXM 1600mm x 800mm Back Inner Panel		Detail Rev.
Part Number Numéro Pièce	Rev. 0	18
<b>6500MXK160810BIP</b>		18

Qty	Part Number	Rev	Description
1	STK-A-49005	5	6500 MXM - Bottom Inner Panel Support Assembly (Right)
1	STK-A-49000	5	6500 MXM - Bottom Inner Panel Support Assembly (Left)
1	STK-A-49015	0	6500MXM - Top Inner Panel Support Kit (Right)
1	STK-A-49010	0	6500MXM - Top Inner Panel Support Kit (Left)
1	6500MXK160810BIP-P	0	6500 MXM 1600mm x 800mm Back Inner Panel Part
Parts List			