

This drawing is confidential and must not be reproduced or used without the consent of EXM

Ce dessin est confidentiel et ne doit pas être reproduit ou utilisé sans le consentement de EXM

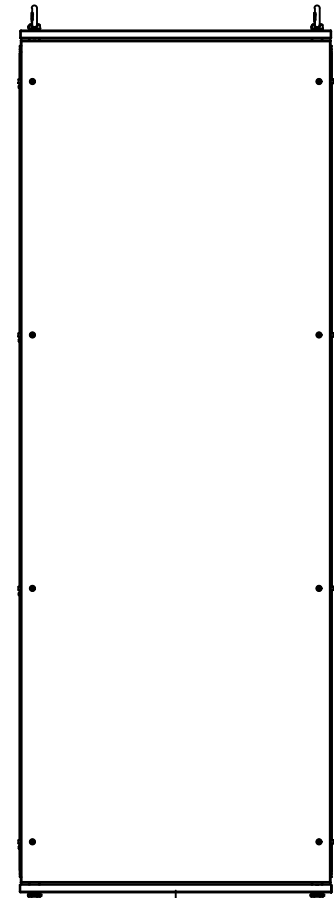

TOP



BACK

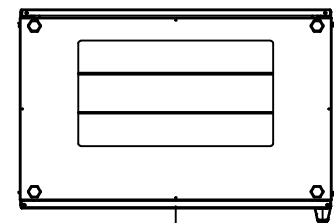

BOTTOM

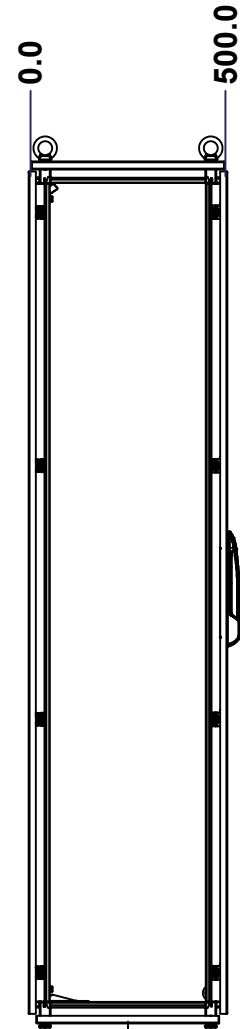

LEFT

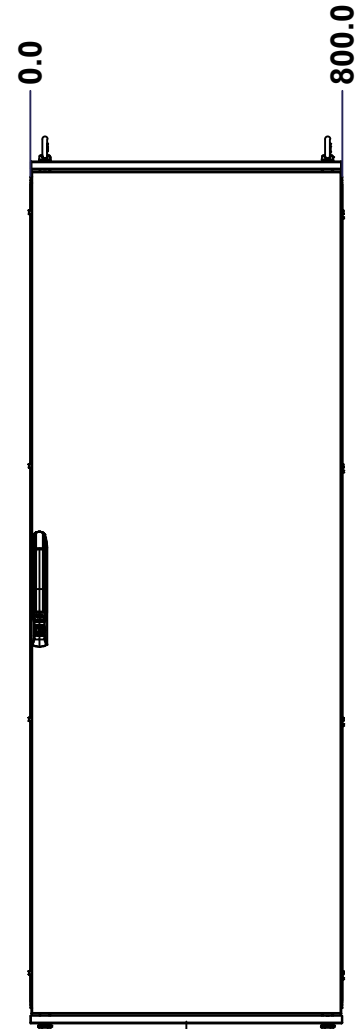

FRONT

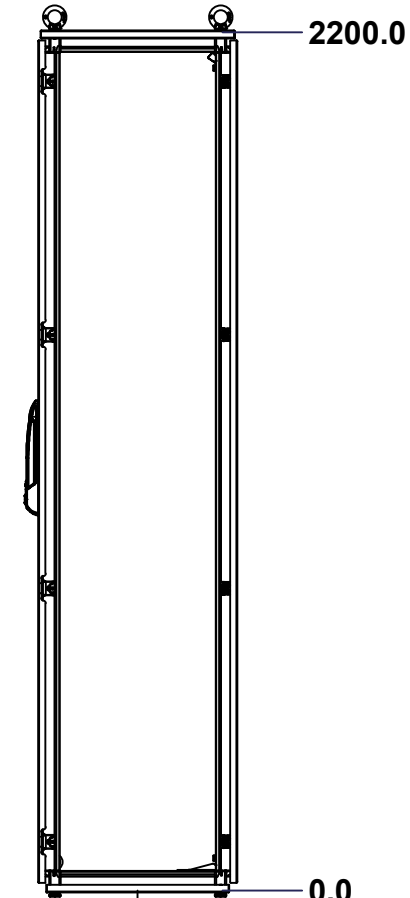

RIGHT

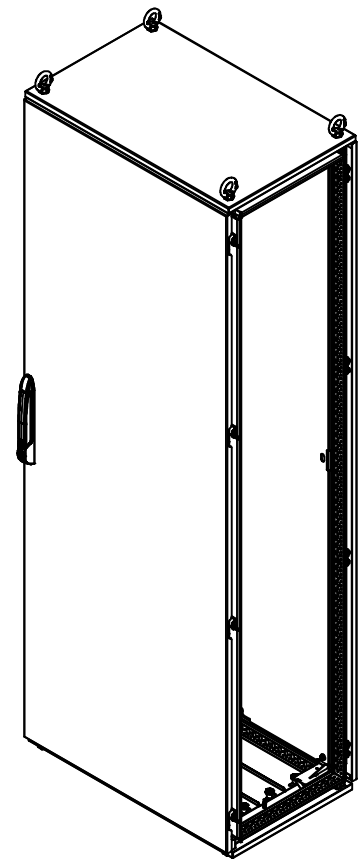

Isometric View

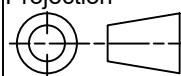

No.	Revisions	Date	By/Par

 Tél: (450) 979-4373 Fax: (450) 979-4626 www.exmweb.com		Flatness Aplatissement Max 3.0mm Projection 
Customer Client		Date
Drawn By Dessiné Par	BoxCad: BoxCad	Date 25-Feb-15
Material Matière	See Part List	
Color Couleur	See Part List	Finish Fini See Part List
Description	Detail Rev.	
6500MX 2200mm x 800mm x 500mm Assembly		
Part Number Numéro Pièce	Rev.	1
6500MXK220805	0	18

SEE BILL OF MATERIAL ON LAST PAGE

This drawing is confidential and must not be reproduced or used without the consent of EXM

Ce dessin est confidentiel et ne doit pas être reproduit ou utilisé sans le consentement de EXM

No.	Revisions	Date	By/Par

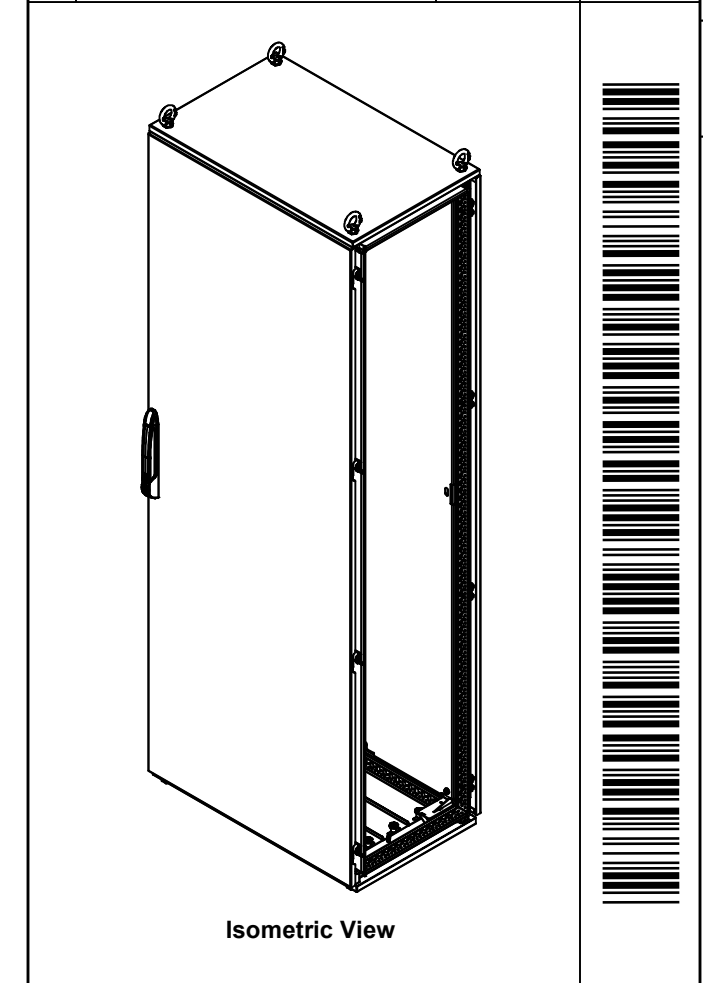

Tél: (450) 979-4373 Fax: (450) 979-4626 www.exmweb.com		Flatness Aplatissement Max 3.0mm
		Projection
Customer Client	Date	
Drawn By Dessiné Par	BoxCad: BoxCad	Date 25-Feb-15
Material Matière	See Part List	
Color Couleur	See Part List	Finish Fini See Part List
Description 6500MX 2200mm x 800mm x 500mm Assembly		Detail Rev.
Part Number Numéro Pièce	6500MXK220805	Rev. 2 0

Qty	Part Number	Rev	Description
1	6500MXK220805BIP	0	6500 MXM 2200mm x 800mm Back Inner Panel
1	6500MXK220805F	0	6500 MXD 2200mm x 800mm Front
1	6500MXK220805B	0	6500 MXR 2200mm x 800mm Back
1	6500MXK220805BT	0	6500 MXB 800mm x 500mm Bottom
1	6500MXK220805T	0	6500 MXT 800mm x 500mm Top
1	6500MXK220805FR	0	6500 MX 2200mm x 800mm x 500mm Frame
Parts List			

This drawing is confidential and must not be reproduced or used without the consent of EXM

Ce dessin est confidentiel et ne doit pas être reproduit ou utilisé sans le consentement de EXM

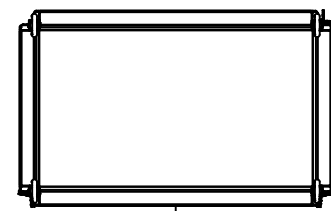

TOP

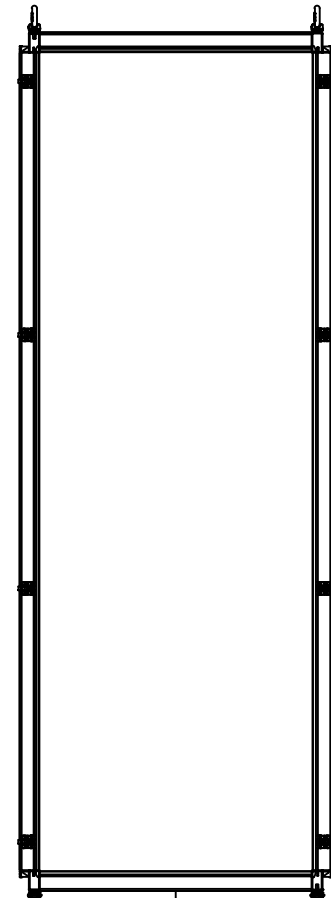

BACK

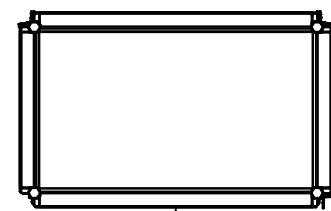

BOTTOM

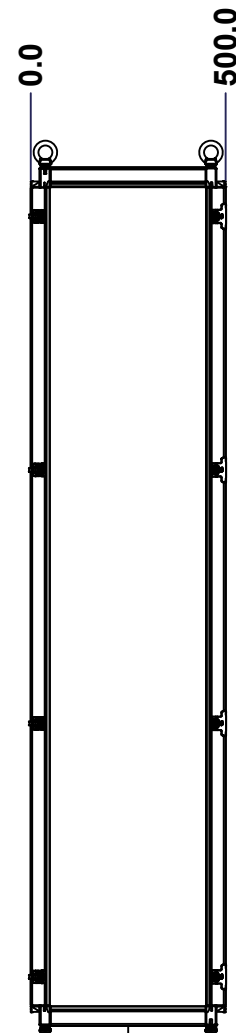

LEFT

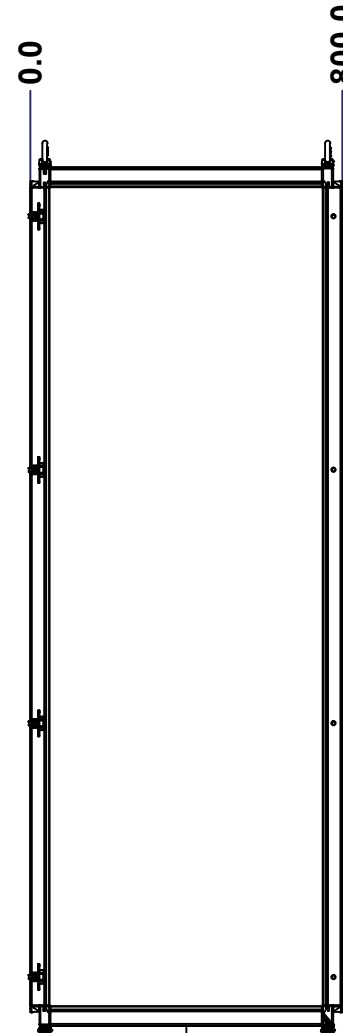

FRONT

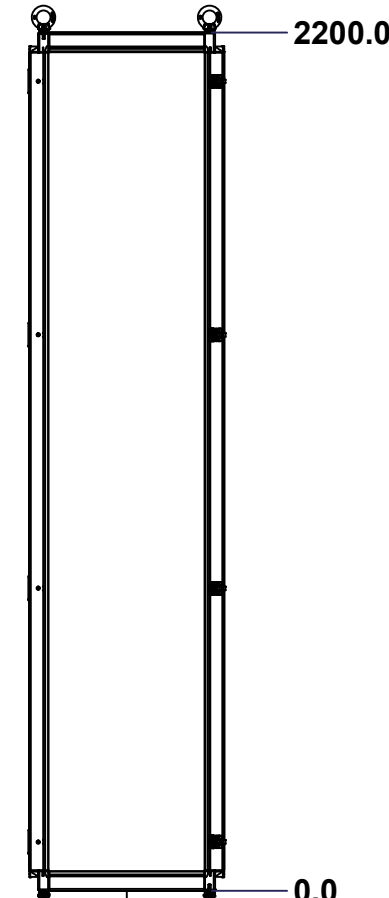

RIGHT

Grind excess weld off corner(s)

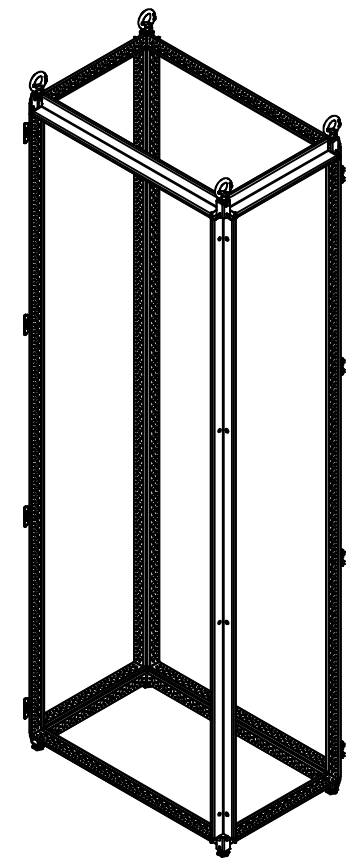

Isometric View

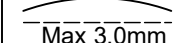
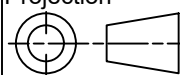

No.	Revisions	Date	By/Par

 Tél: (450) 979-4373 Fax: (450) 979-4626 www.exmweb.com		Flatness Aplatissement  Max 3.0mm Projection 
Customer Client		Date
Drawn By Dessiné Par	BoxCad: BoxCad	Date 25-Feb-15
Material Matière	16 Ga Electro-Galvanized (1.4mm)	
Color Couleur	Iron Grey RAL7011	Finish Fini Textured
Description 6500 MX 2200mm x 800mm x 500mm Frame		Detail Rev.
Part Number Numéro Pièce	6500MXK220805FR	Rev. 3 0

SEE BILL OF MATERIAL ON LAST PAGE

This drawing is confidential and must not be reproduced or used without the consent of EXM

Ce dessin est confidentiel et ne doit pas être reproduit ou utilisé sans le consentement de EXM

No.	Revisions	Date	By/Par

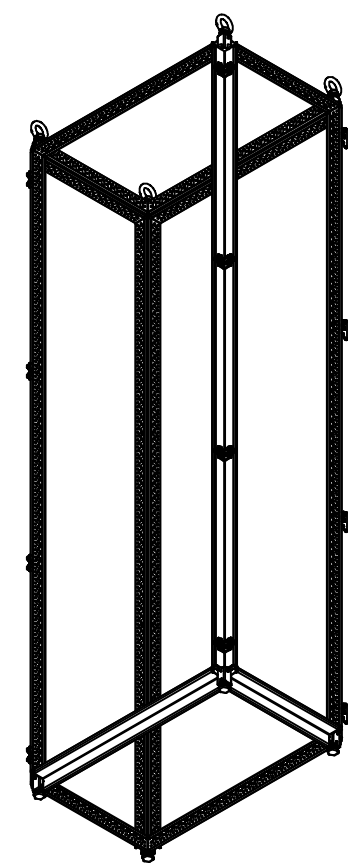

Isometric View

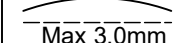

Qty	Part Number	Rev	Description
1	STK-P-03810ST	0	Powder Paint (Iron Grey /Sand Textured)
4	STK-Q-47250-08	6	6500 MX 800mm Horizontal Frame Post Part
4	STK-Q-47250-05	6	6500 MX 500mm Horizontal Frame Post Part
4	STK-A-70589	9	6500 MX Fixed Side Panel Bracket Assembly
16	STK-Q-77120	1	6500MX-Frame Rubber Plug
8	STK-A-70580	9	Mtrx Bracket
8	STK-Q-00610	3	M16 x 30.0mm Bolt
8	STK-A-49448	6	6500 MX - Frame Sheet Metal Corner Assembly
4	STK-Q-49500	3	M12 Eye Bolt (0.34T)
4	STK-Q-61110	0	M12 Feet Leveler
4	STK-Q-47251-22	6	6500 MX 2200mm Vertical Frame Post Part
Parts List			

 Tél: (450) 979-4373 Fax: (450) 979-4626 www.exmweb.com		Flatness Aplatissement  Max 3.0mm
Customer Client		Date
Drawn By Dessiné Par BoxCad: BoxCad		Date 25-Feb-15
Material Matière 16 Ga Electro-Galvanized (1.4mm)		
Color Couleur Iron Grey RAL7011	Finish Fini Textured	
Description 6500 MX 2200mm x 800mm x 500mm Frame		Detail Rev.
Part Number Numéro Pièce 6500MXK220805FR		Rev. 4 0

This drawing is confidential and must not be reproduced or used without the consent of EXM

Ce dessin est confidentiel et ne doit pas être reproduit ou utilisé sans le consentement de EXM



TOP

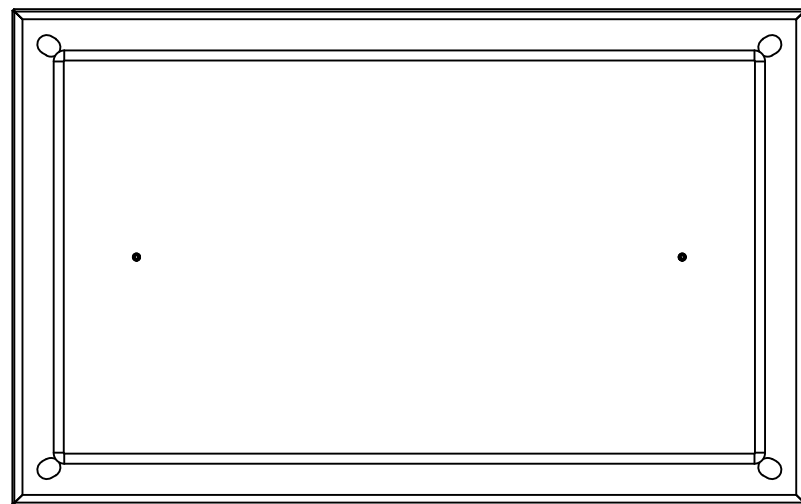

BACK

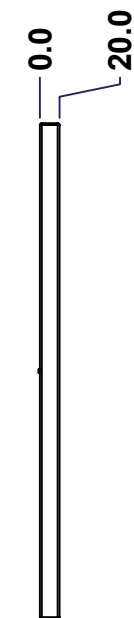

LEFT

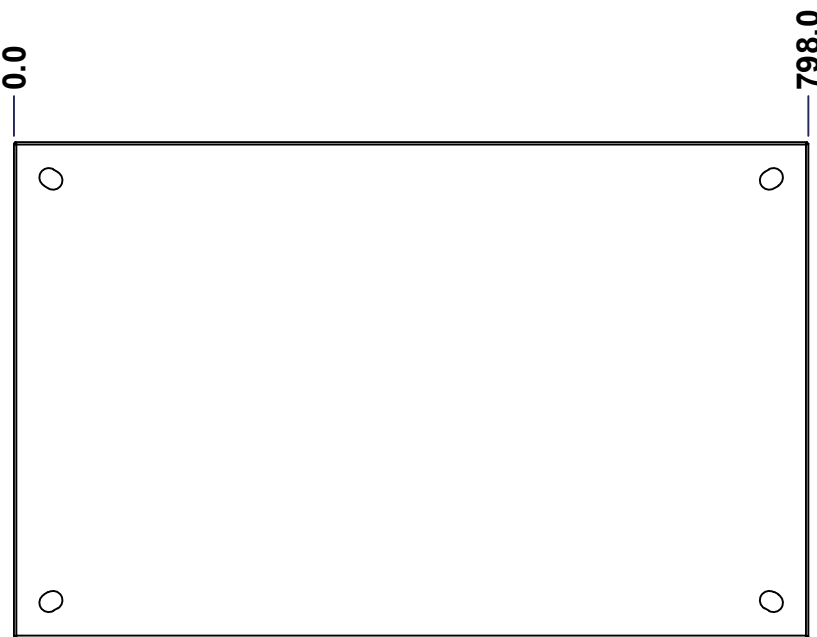

FRONT

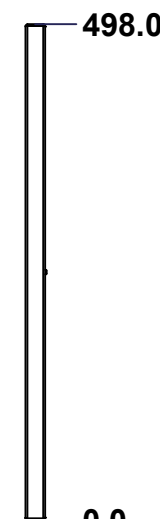

RIGHT

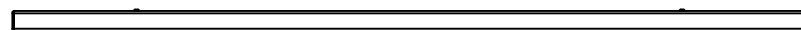

BOTTOM

No.	Revisions	Date	By/Par

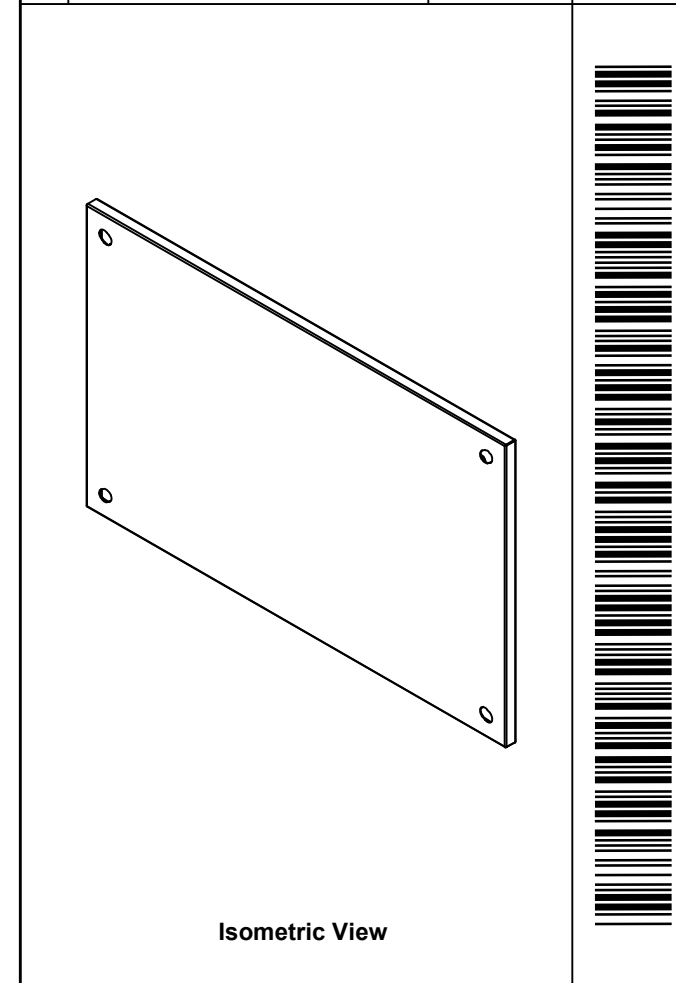

	Flatness Aplatissement Max 3.0mm
	Projection 

Customer Client	Date
Drawn By / Dessiné Par: BoxCad: BoxCad	Date: 25-Feb-15

Material / Matière: 16 Ga Cold Rolled A1008 CS Type B

Color / Couleur: Iron Grey RAL7011	Finish / Fini: Textured
------------------------------------	-------------------------

Description: 6500 MXT 800mm x 500mm Top	Detail Rev.
---	-------------

Part Number / Numéro Pièce: 6500MXK220805T	Rev. 0	5	18
--	--------	---	----

Use gasket program path 6500 MX > 6500 MXT

SEE BILL OF MATERIAL ON LAST PAGE

This drawing is confidential and must not be reproduced or used without the consent of EXM

Ce dessin est confidentiel et ne doit pas être reproduit ou utilisé sans le consentement de EXM

STANDARD FEATURES ARE NOT LISTED IN THIS HOLE TABLE			
HOLE TABLE - FRONT VIEW (CUSTOM FEATURE ONLY)			
CUT-OUT	XDIM	YDIM	DESCRIPTION
1	125.0	249.0	GND STUD M6 x 18mm (Inside)
2	673.0	249.0	GND STUD M6 x 18mm (Inside)

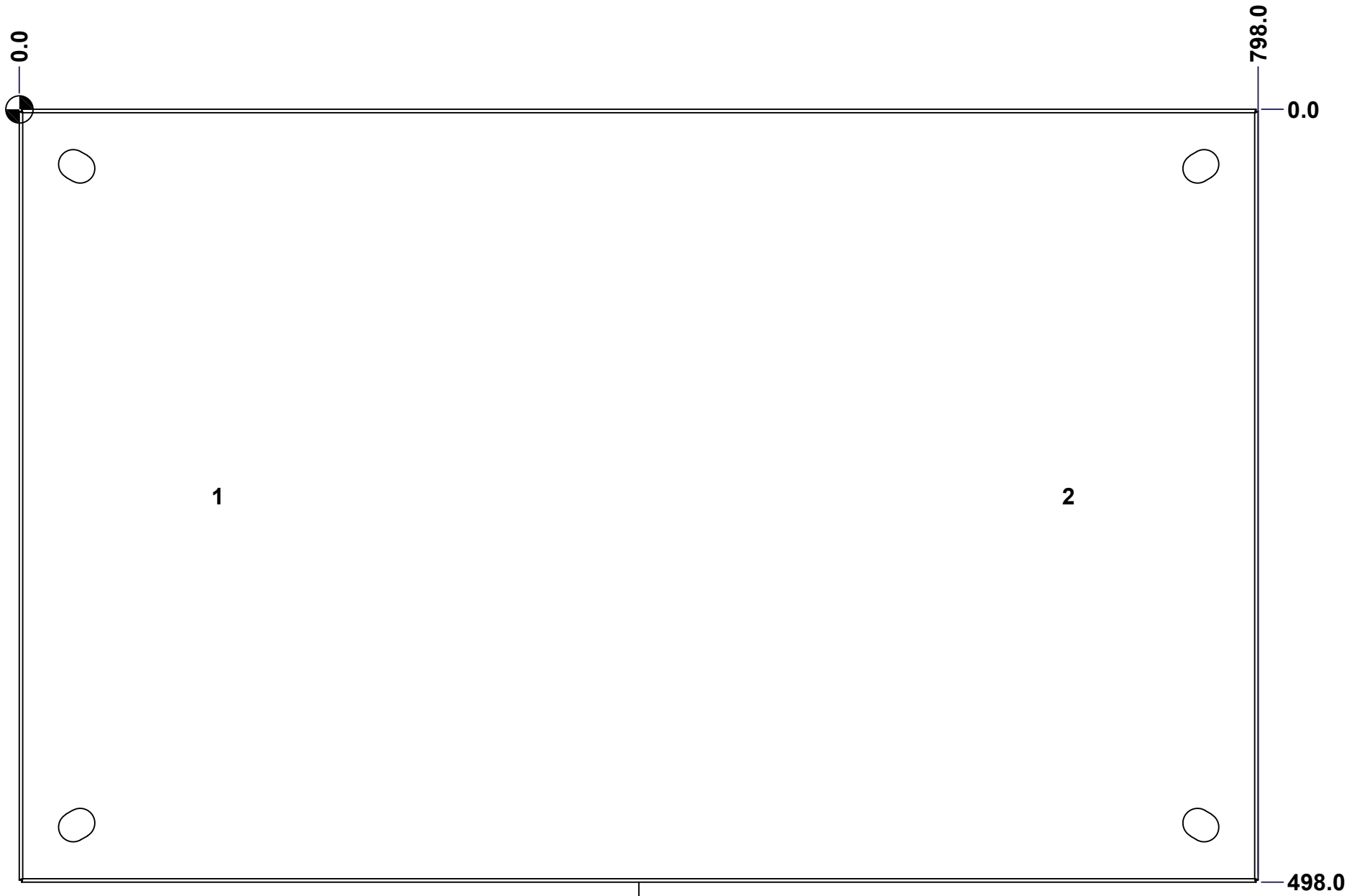

FRONT

Use bending program path 6500 MX > 6500 MXT

	Description	Status
	6500 MXT 800mm x 500mm Top	(NULL)
	Part Number Numéro Pièce	Rev.
	6500MXK220805T	0 / 6
		18

This drawing is confidential and must not be reproduced or used without the consent of EXM

Ce dessin est confidentiel et ne doit pas être reproduit ou utilisé sans le consentement de EXM

No.	Revisions	Date	By/Par

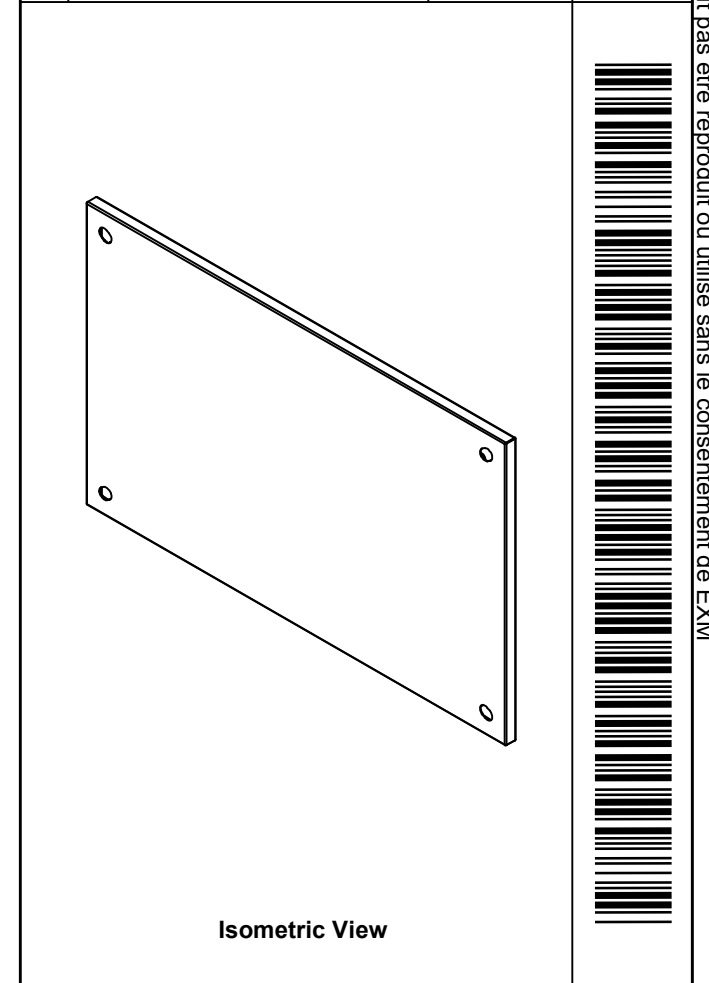

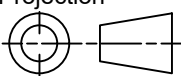
 Tél: (450) 979-4373 Fax: (450) 979-4626 www.exmweb.com		Flatness Aplatissement Max 3.0mm Projection 
Customer Client	Date	
Drawn By Dessiné Par	BoxCad: BoxCad	Date 25-Feb-15
Material Matière	16 Ga Cold Rolled A1008 CS Type B	
Color Couleur	Iron Grey RAL7011	Finish Fini Textured
Description		Detail Rev.
6500 MXT 800mm x 500mm Top		
Part Number Numéro Pièce		Rev. 7
6500MXK220805T		0 18

Qty	Part Number	Rev	Description
1	STK-P-03810ST	0	Powder Paint (Iron Grey /Sand Textured)
2	STK-Q-16055	1	M6 x 18mm Stud (No Paint Cap Required)
1	6500MXK220805TG	0	6500 MXT 800mm x 500mm Top Gasket
1	6500MXK220805T-P	0	6500 MXT 800mm x 500mm Top Part
Parts List			

This drawing is confidential and must not be reproduced or used without the consent of EXM

Ce dessin est confidentiel et ne doit pas être reproduit ou utilisé sans le consentement de EXM

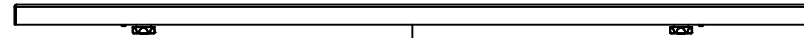

TOP

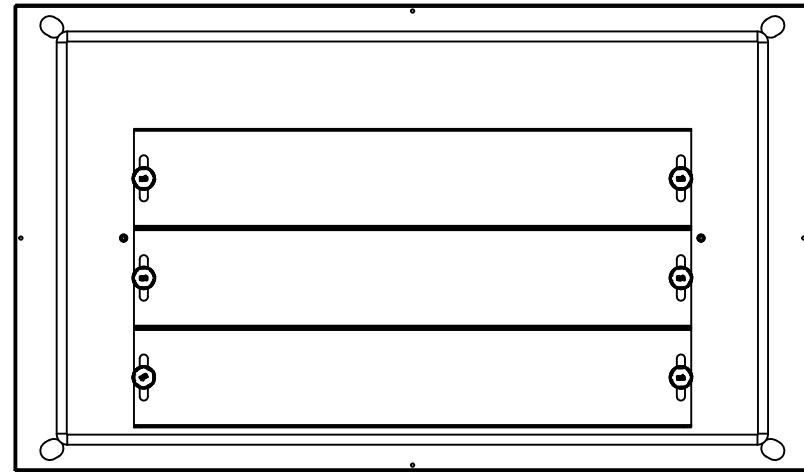

BACK

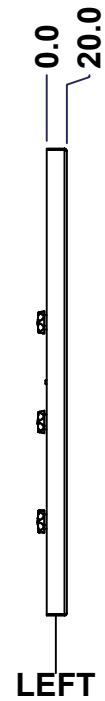

LEFT

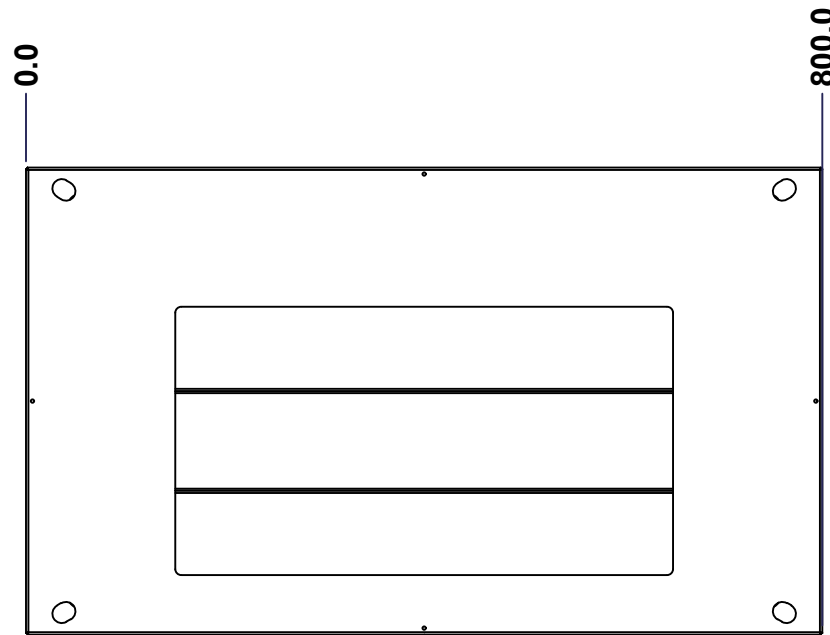

FRONT

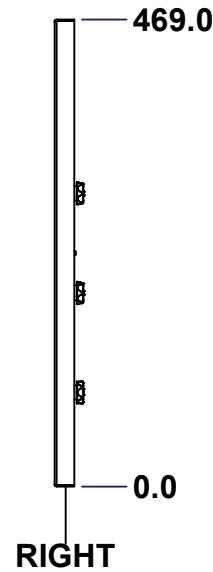

RIGHT

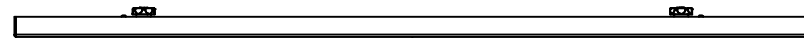

BOTTOM

No.	Revisions	Date	By/Par

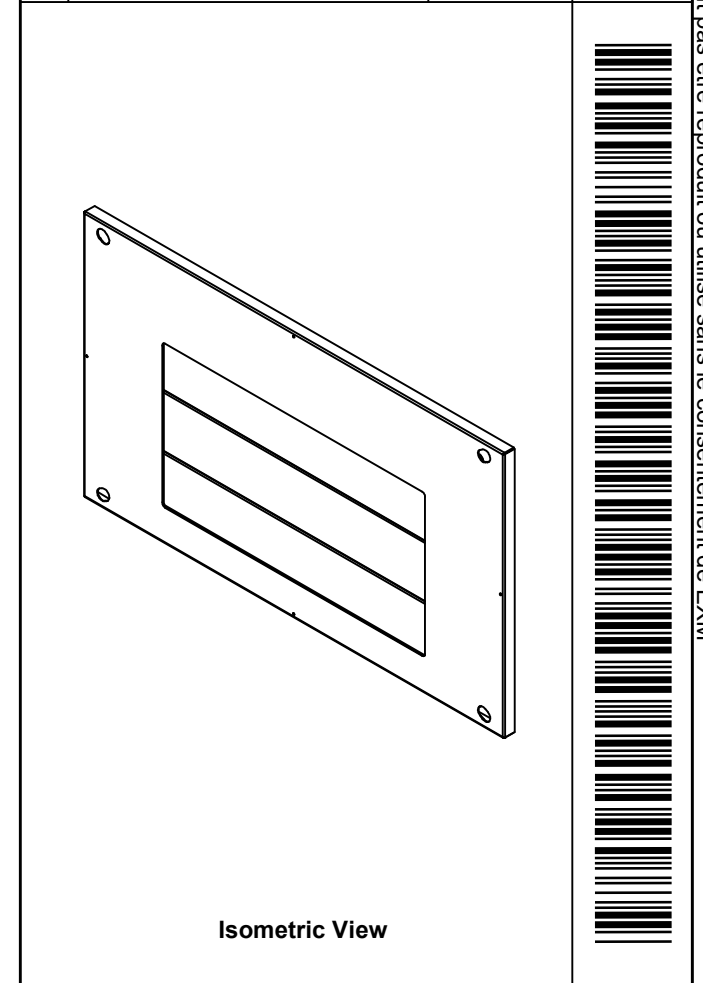

Isometric View



Tél: (450) 979-4373
 Fax: (450) 979-4626
www.exmweb.com

Flatness
Aplatissement

Max 3.0mm

Projection

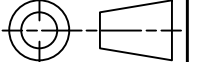

Customer Client	Date
Drawn By / Dessiné Par: BoxCad: BoxCad	Date: 25-Feb-15
Material / Matière: 16 Ga Cold Rolled A1008 CS Type B	

Color / Couleur: Iron Grey RAL7011	Finish / Fini: Textured
------------------------------------	-------------------------

Description: 6500 MXB 800mm x 500mm Bottom	Detail Rev.
--	-------------

Part Number / Numéro Pièce: 6500MXK220805BT	Rev. 0	8	18
--	--------	---	----

Use gasket program path 6500 MX > 6500MXB

SEE BILL OF MATERIAL ON LAST PAGE

This drawing is confidential and must not be reproduced or used without the consent of EXM

Ce dessin est confidentiel et ne doit pas être reproduit ou utilisé sans le consentement de EXM

STANDARD FEATURES ARE NOT LISTED IN THIS HOLE TABLE

HOLE TABLE - FRONT VIEW (CUSTOM FEATURE ONLY)

CUT-OUT	XDIM	YDIM	DESCRIPTION
1	110.0	234.5	GND STUD M6 x 18mm (Inside)
2	690.0	234.5	GND STUD M6 x 18mm (Inside)
3	130.0	294.5	GP STUD M6 x 18mm (Inside)
4	670.0	294.5	GP STUD M6 x 18mm (Inside)
5	130.0	194.5	GP STUD M6 x 18mm (Inside)
6	670.0	194.5	GP STUD M6 x 18mm (Inside)
7	130.0	94.5	GP STUD M6 x 18mm (Inside)
8	670.0	94.5	GP STUD M6 x 18mm (Inside)

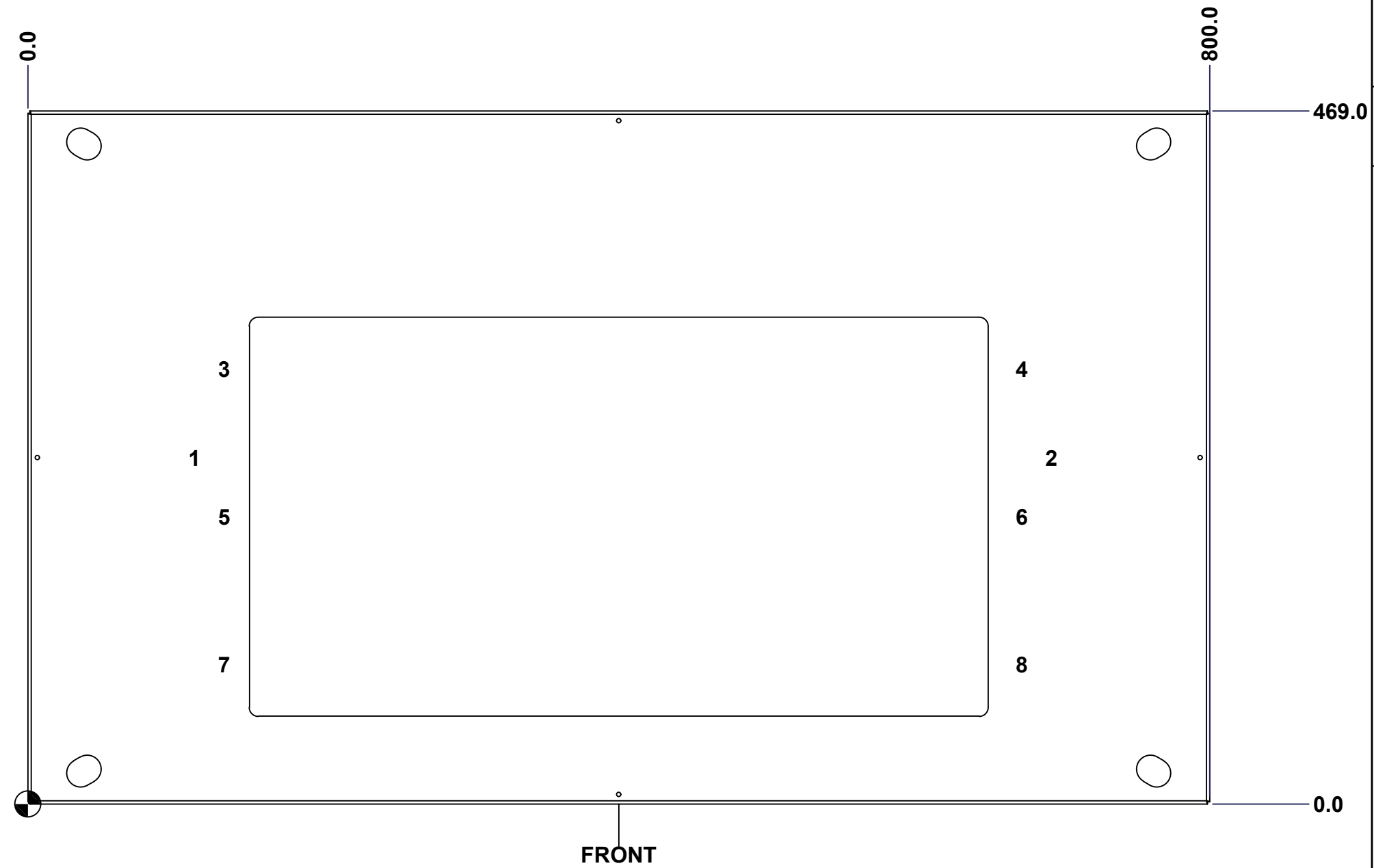

Use bending program path 6500 MX > 6500MXB

	Description	Status
	6500 MXB 800mm x 500mm Bottom	(NULL)
	Part Number Numéro Pièce	Rev.
	6500MXK220805BT	0 / 9
		18

This drawing is confidential and must not be reproduced or used without the consent of EXM

Ce dessin est confidentiel et ne doit pas être reproduit ou utilisé sans le consentement de EXM

No.	Revisions	Date	By/Par

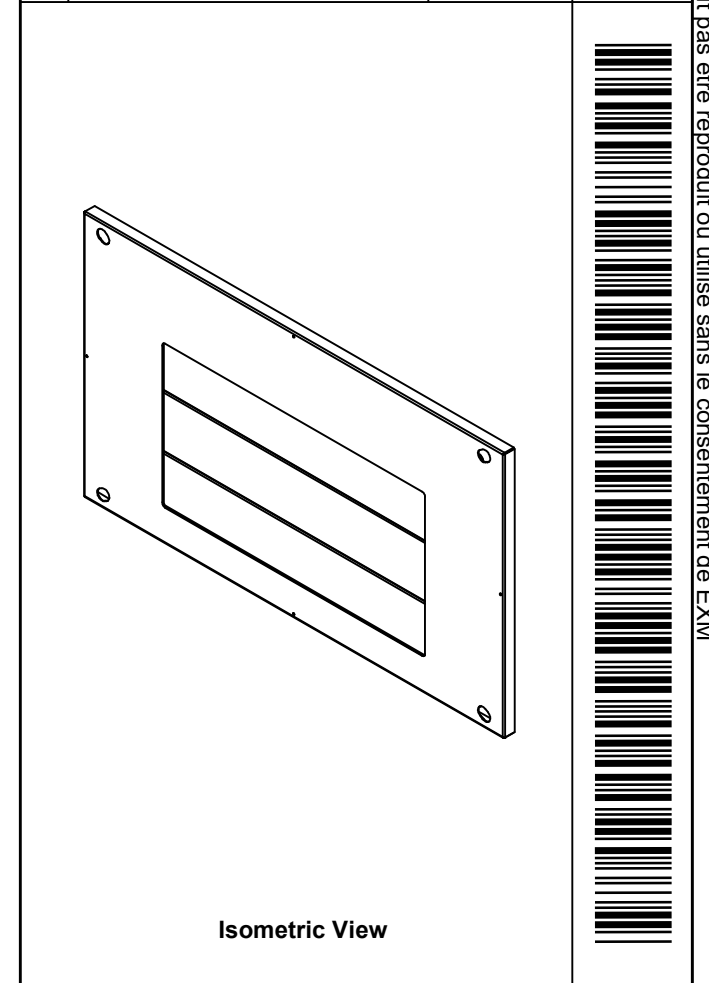

 Tél: (450) 979-4373
 Fax: (450) 979-4626
www.exmweb.com

Flatness
 Aplatissement

 Max 3.0mm
Projection

Customer Client	Date
Drawn By / Dessiné Par: BoxCad: BoxCad	Date: 25-Feb-15

Material / Matière: 16 Ga Cold Rolled A1008 CS Type B

Color / Couleur: Iron Grey RAL7011	Finish / Fini: Textured
------------------------------------	-------------------------

Description: 6500 MXB 800mm x 500mm Bottom	Detail Rev.
--	-------------

Part Number / Numéro Pièce: 6500MXK220805BT	Rev. / Révis: 0	10
		18

Qty	Part Number	Rev	Description
1	STK-P-03810ST	0	Powder Paint (Iron Grey /Sand Textured)
6	STK-Q-06001	0	Mtrx - Gland Plate M6 Plastic Thumb Nut
8	STK-Q-16055	1	M6 x 18mm Stud (No Paint Cap Required)
3	6500MXK220805GP100-P	0	6500 MXB 800mm Gland Plate Part (100mm)
1	6500MXK220805BTGPG	0	6500 MXB 800mm x 500mm Bottom Gland Plate Gasket
1	6500MXK220805BTG	0	6500 MXB 800mm x 500mm Bottom Gasket
1	6500MXK220805BT-P	0	6500 MXB 800mm x 500mm Bottom Part
Parts List			

This drawing is confidential and must not be reproduced or used without the consent of EXM

Ce dessin est confidentiel et ne doit pas être reproduit ou utilisé sans le consentement de EXM

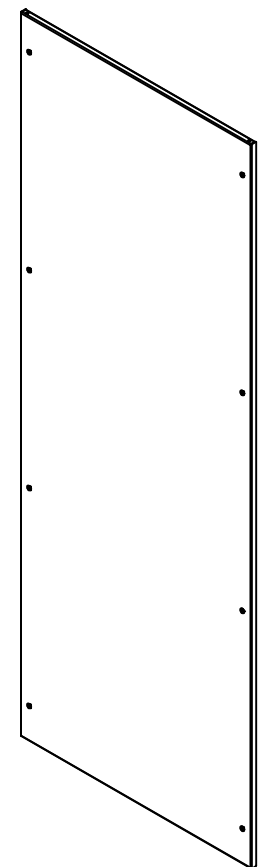
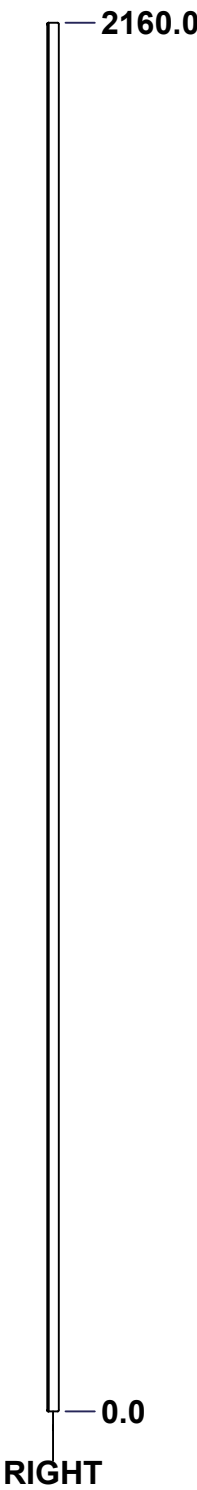
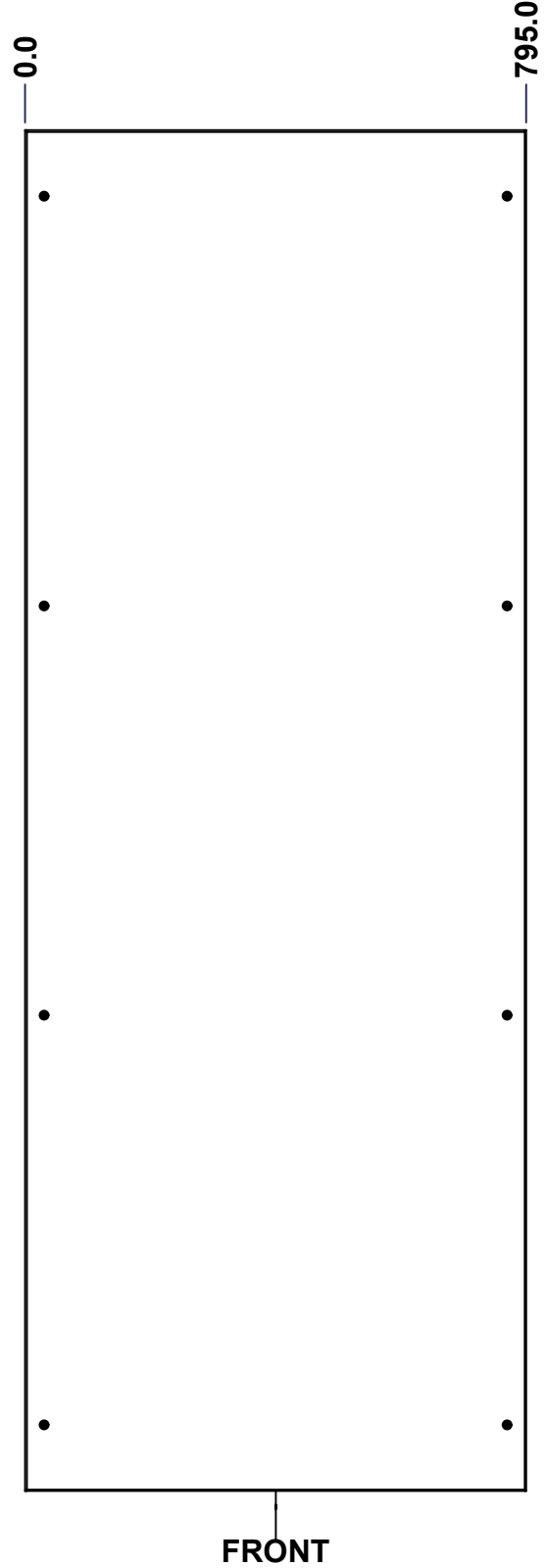
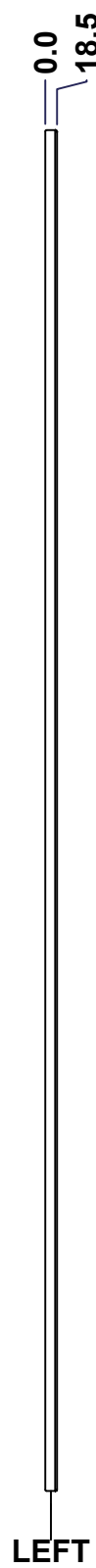
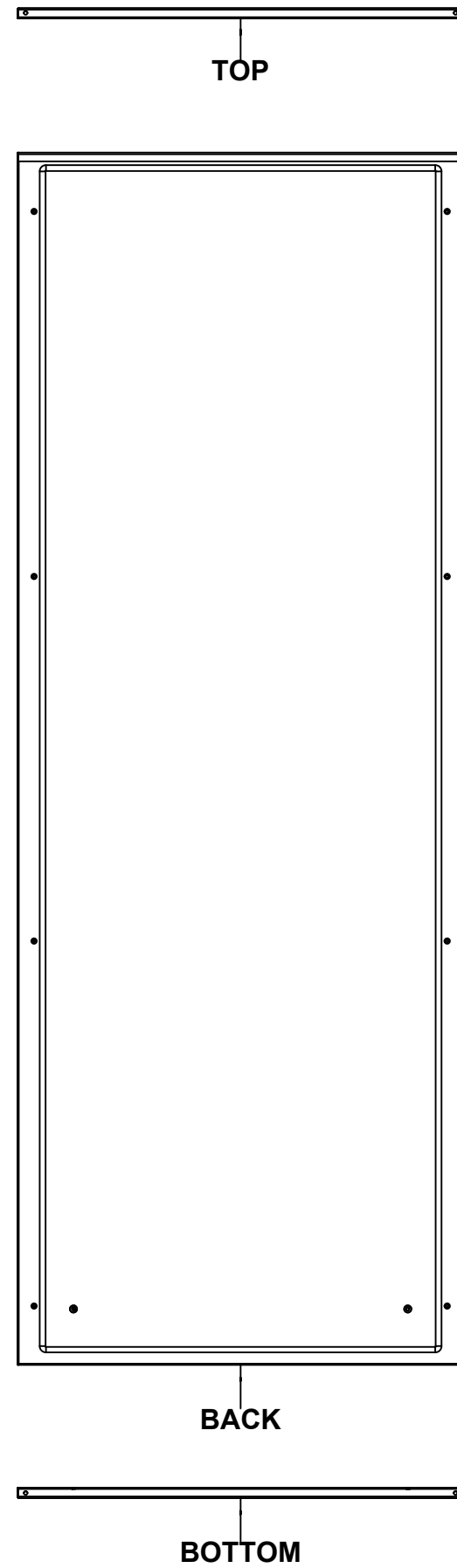

Isometric View

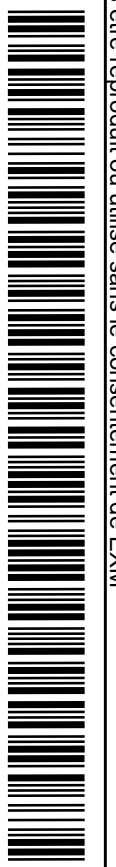

No.	Revisions	Date	By/Par

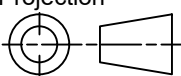
 Tél: (450) 979-4373 Fax: (450) 979-4626 www.exmweb.com		Flatness Aplatissement Max 3.0mm Projection 
Customer Client	Date	
Drawn By Dessiné Par	BoxCad: BoxCad	Date 25-Feb-15
Material Matière	14 Ga Cold Rolled A1008 CS Type B	
Color Couleur	Light Grey RAL7035	Finish Fini Textured
Description 6500 MXR 2200mm x 800mm Back		Detail Rev.
Part Number Numéro Pièce	Rev. 0	11 / 18

Use gasket program path 6500 MX > 6500 MXR

SEE BILL OF MATERIAL ON LAST PAGE

6500MXK220805B

This drawing is confidential and must not be reproduced or used without the consent of EXM

Ce dessin est confidentiel et ne doit pas être reproduit ou utilisé sans le consentement de EXM

STANDARD FEATURES ARE NOT LISTED IN THIS HOLE TABLE			
HOLE TABLE - FRONT VIEW (CUSTOM FEATURE ONLY)			
CUT-OUT	XDIM	YDIM	DESCRIPTION
1	100.0	100.0	GND STUD M6 x 16mm (Inside)
2	695.0	100.0	GND STUD M6 x 16mm (Inside)

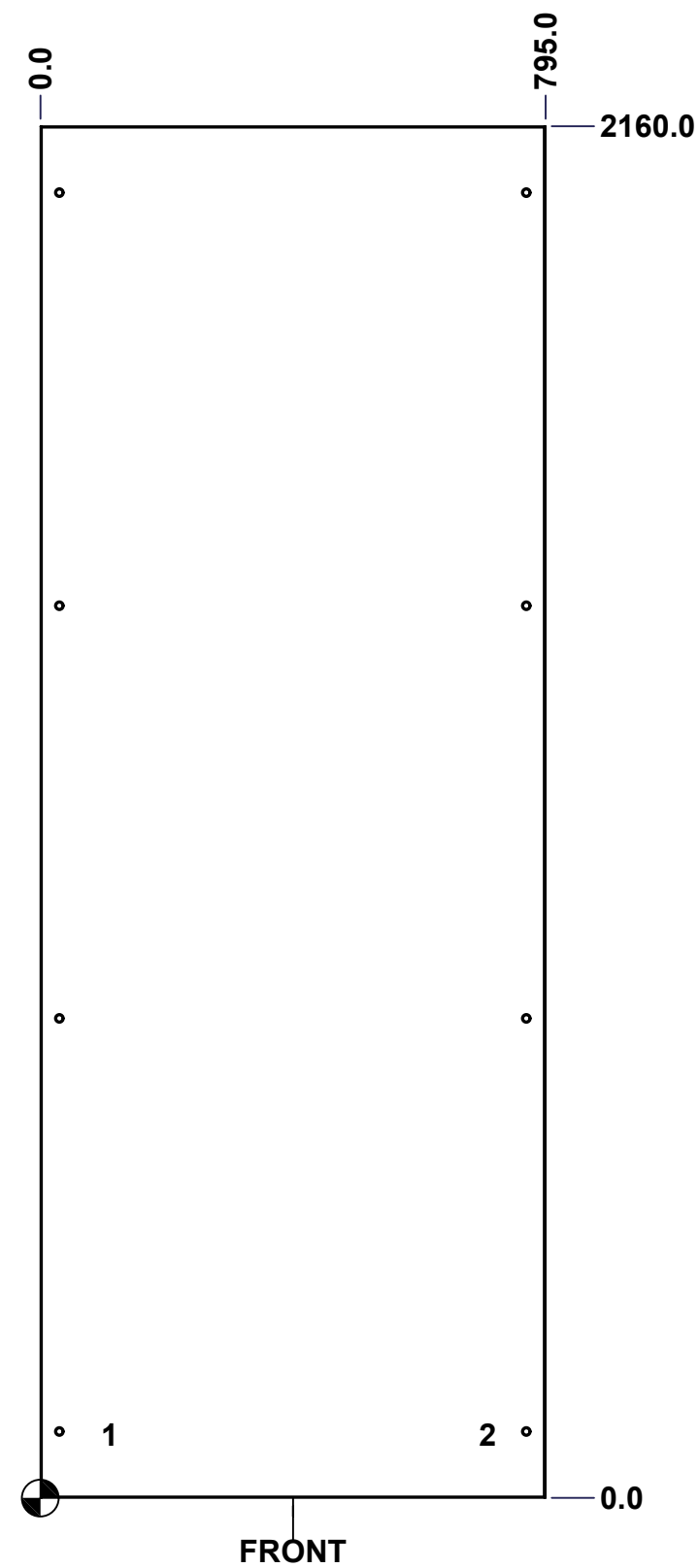

Use bending program path 6500 MX > 6500 MXR

	Description	Status
	6500 MXR 2200mm x 800mm Back	(NULL)
	Part Number Numéro Pièce	Rev.
	6500MXK220805B	0
		12
		18

This drawing is confidential and must not be reproduced or used without the consent of EXM

Ce dessin est confidentiel et ne doit pas être reproduit ou utilisé sans le consentement de EXM

No.	Revisions	Date	By/Par

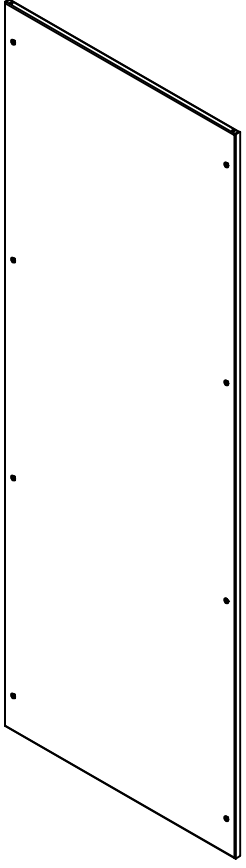

Isometric View

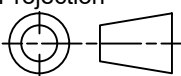

		Flatness Aplatissement Max 3.0mm	
Tél: (450) 979-4373 Fax: (450) 979-4626 www.exmweb.com		Projection 	
Customer Client		Date	
Drawn By / Dessiné Par: BoxCad: BoxCad		Date: 25-Feb-15	
Material / Matière: 14 Ga Cold Rolled A1008 CS Type B			
Color / Couleur: Light Grey RAL7035		Finish / Fini: Textured	
Description: 6500 MXR 2200mm x 800mm Back			Detail Rev.
Part Number / Numéro Pièce: 6500MXK220805B			Rev. 13
			0
			18

Qty	Part Number	Rev	Description
1	STK-P-03820R	0	Powder Paint (Light Grey / Rough Textured)
1	6500MXK220805BG	0	6500 MXR 2200mm x 800mm Back Gasket
8	STK-Q-03071	0	M6 x 16mm Machine Screw
2	STK-Q-16080	0	Ground Stud M6 x 16mm Steel
1	6500MXK220805B-P	0	6500 MXR 2200mm x 800mm Back Part
Parts List			

This drawing is confidential and must not be reproduced or used without the consent of EXM

Ce dessin est confidentiel et ne doit pas être reproduit ou utilisé sans le consentement de EXM

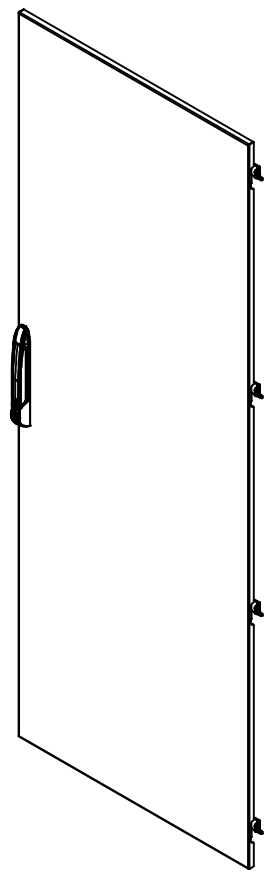
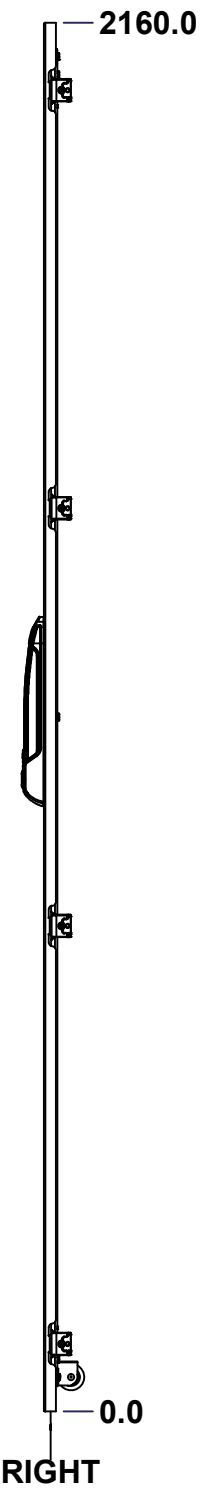
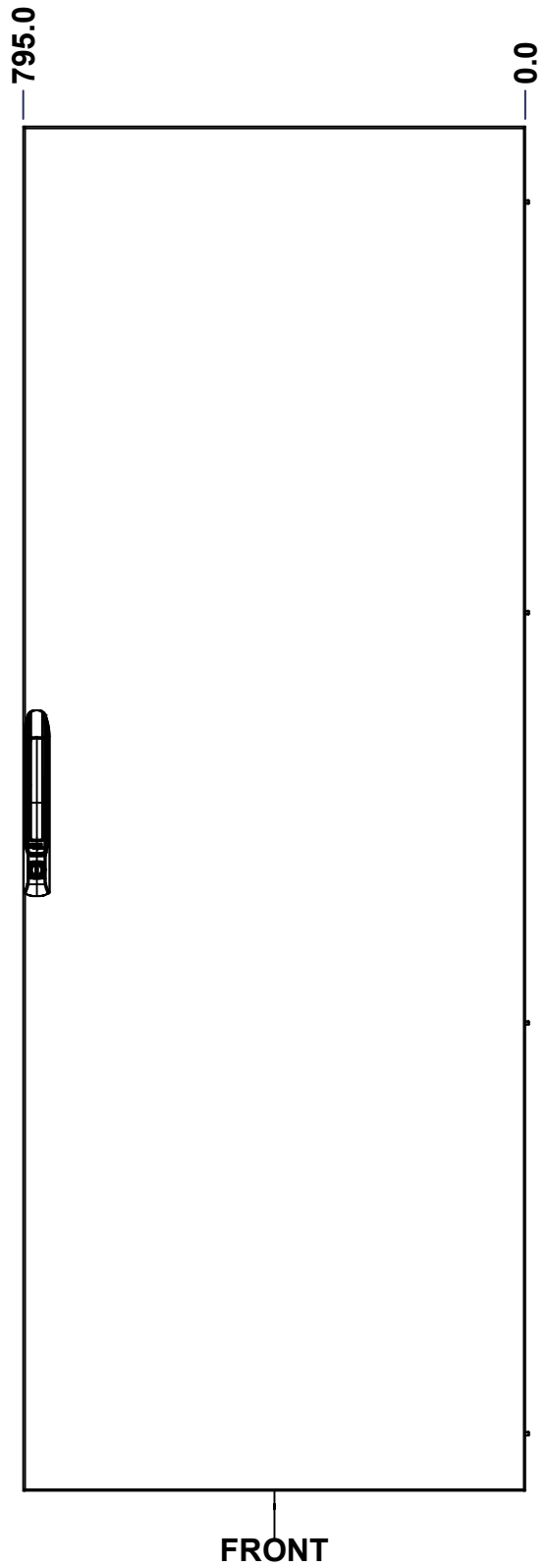
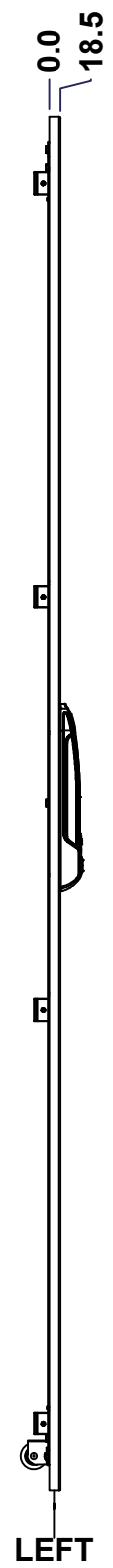
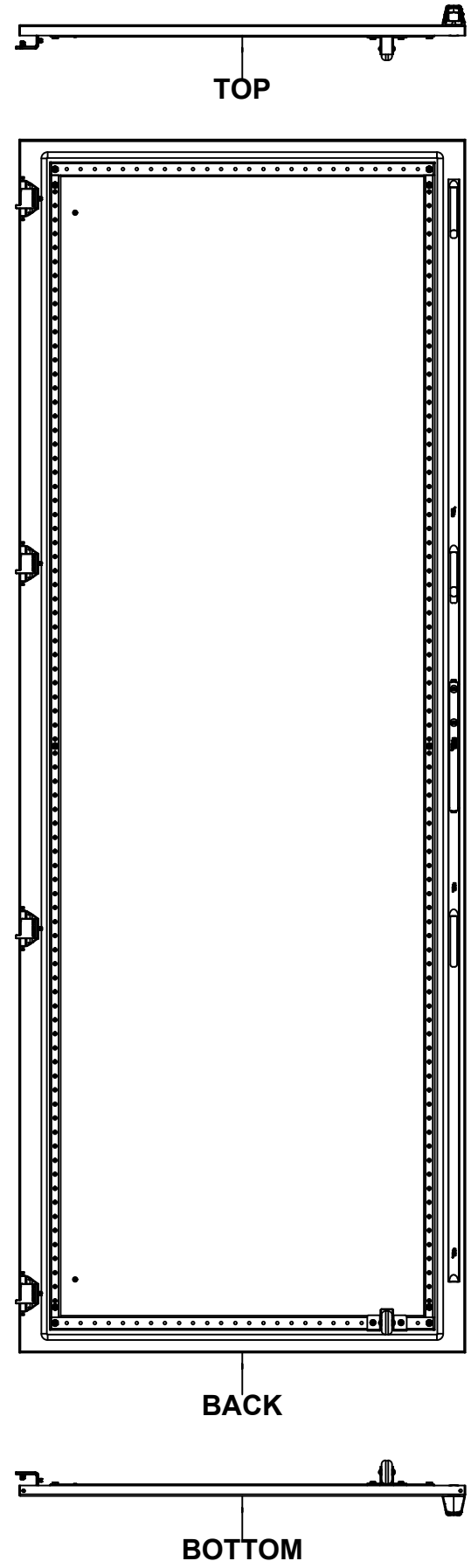

Isometric View

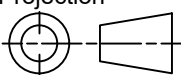

No.	Revisions	Date	By/Par

 Tél: (450) 979-4373 Fax: (450) 979-4626 www.exmweb.com		Flatness Aplatissement Max 3.0mm Projection 
Customer Client	Date	
Drawn By Dessiné Par	BoxCad: BoxCad	Date 25-Feb-15
Material Matière	14 Ga Cold Rolled A1008 CS Type B	
Color Couleur	Light Grey RAL7035	Finish Fini Textured
Description		Detail Rev.
6500 MXD 2200mm x 800mm Front		
Part Number Numéro Pièce	Rev.	14
6500MXK220805F	0	18

Use gasket program path 6500 MX > 6500 MXD

SEE BILL OF MATERIAL ON LAST PAGE

This drawing is confidential and must not be reproduced or used without the consent of EXM

Ce dessin est confidentiel et ne doit pas être reproduit ou utilisé sans le consentement de EXM

STANDARD FEATURES ARE NOT LISTED IN THIS HOLE TABLE

HOLE TABLE - FRONT VIEW (CUSTOM FEATURE ONLY)

CUT-OUT	XDIM	YDIM	DESCRIPTION
1	100.0	130.0	GND STUD M6 x 16mm (Inside)
2	100.0	2030.0	GND STUD M6 x 16mm (Inside)
3	64.5	52.8	STIFF. STUD M6 x 18mm (Inside)
4	64.5	2107.2	STIFF. STUD M6 x 18mm (Inside)
5	730.5	52.8	STIFF. STUD M6 x 18mm (Inside)
6	730.5	2107.2	STIFF. STUD M6 x 18mm (Inside)
7	64.5	1080.0	STIFF. STUD M6 x 18mm (Inside)
8	730.5	1080.0	STIFF. STUD M6 x 18mm (Inside)
9	730.5	2079.0	STIFF. STUD M6 x 18mm (Inside)
10	730.5	81.0	STIFF. STUD M6 x 18mm (Inside)
11	64.5	2079.0	STIFF. STUD M6 x 18mm (Inside)
12	64.5	81.0	STIFF. STUD M6 x 18mm (Inside)
13	774.0	170.0	LARGE CBAR GUIDE (Inside)
14	774.0	1990.0	LARGE CBAR GUIDE (Inside)
15	774.0	805.0	LARGE CBAR GUIDE (Inside)
16	774.0	1355.0	LARGE CBAR GUIDE (Inside)

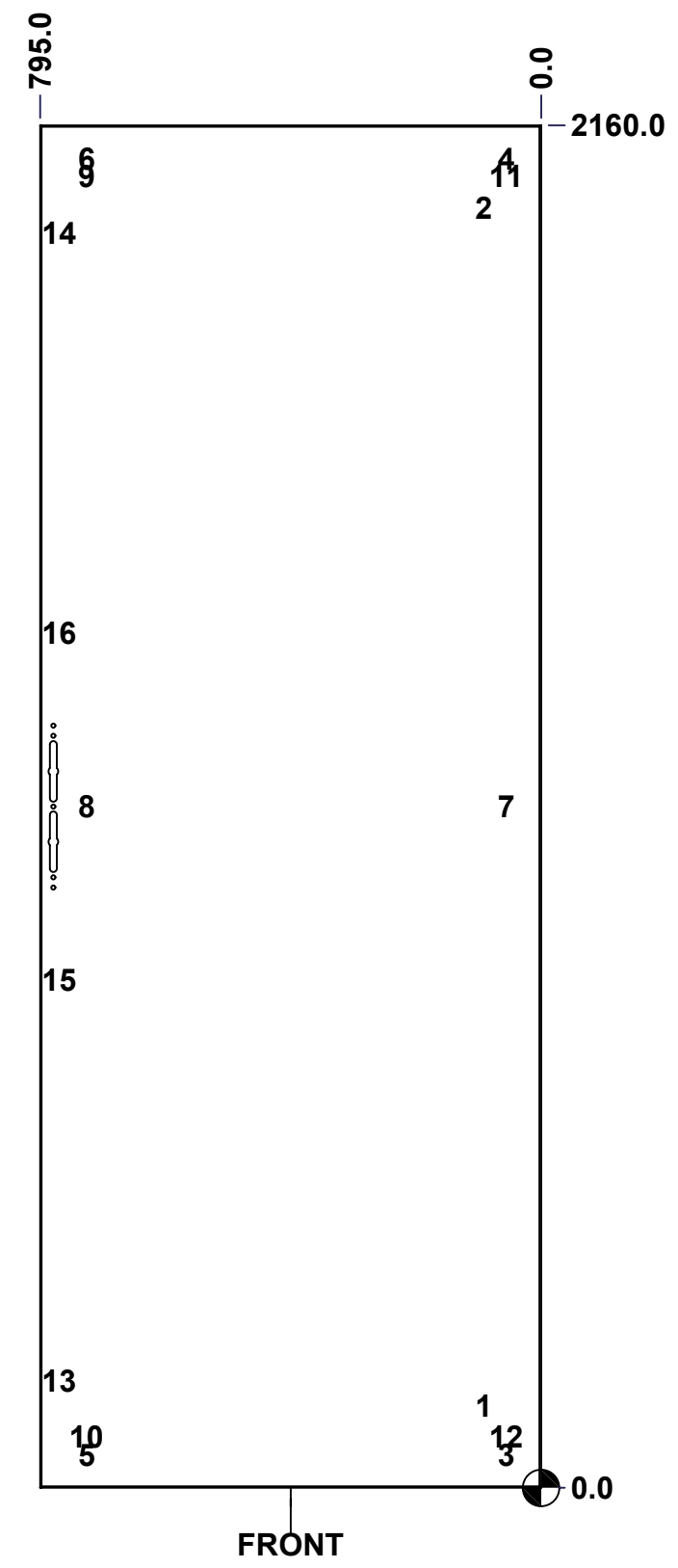

Use bending program path 6500 MX > 6500 MXD

	Description 6500 MXD 2200mm x 800mm Front		Status (NULL)
	Part Number Numéro Pièce 6500MXK220805F		Rev. 0
			15 18

This drawing is confidential and must not be reproduced or used without the consent of EXM

Ce dessin est confidentiel et ne doit pas être reproduit ou utilisé sans le consentement de EXM

No.	Revisions	Date	By/Par

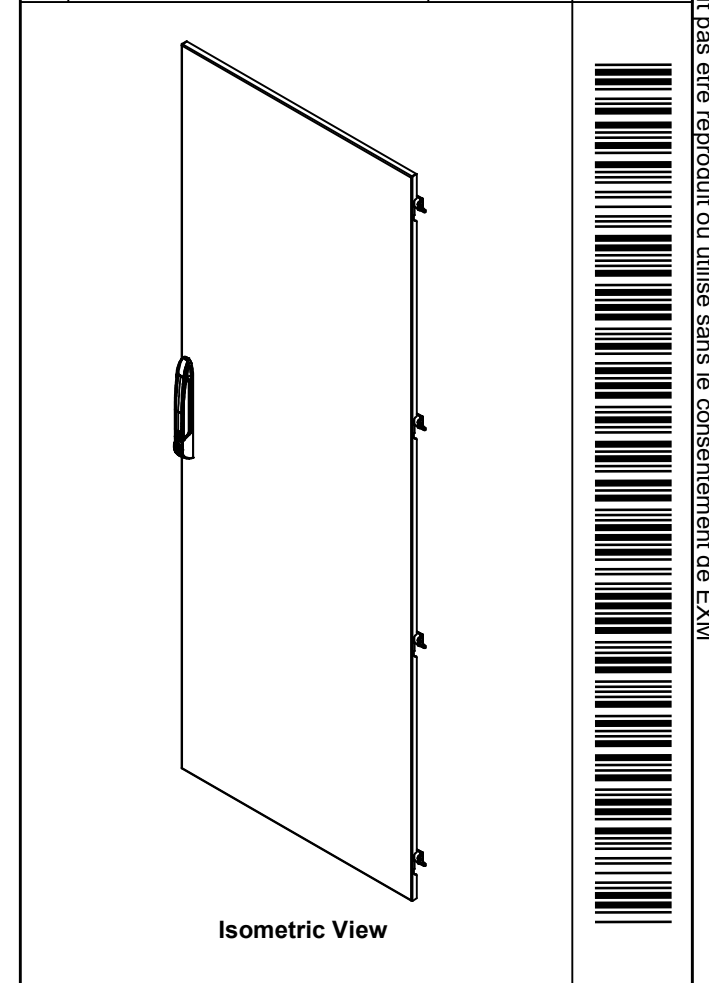

Qty	Part Number	Rev	Description
1	STK-P-03820R	0	Powder Paint (Light Grey / Rough Textured)
1	STK-A-45758	4	886 PH2 Pull Handle Bridge - Assembly
1	STK-A-51160	0	886PH2-SL - Pull Handle Lock - Assembly
1	STK-Q-45662-22	1	6500 MX - Lower Closing Bar 2200mm
1	STK-Q-45661-22	1	6500 MX - Upper Closing Bar 2200mm
1	6500MXSRK	1	6500 MXRSK Door Support Roller
4	STK-Q-16410	0	Guide Stud - Large (No Paint Cap Required)
4	STK-K-06810	7	6500 MX Hinge Assy
12	STK-Q-16055	1	M6 x 18mm Stud (No Paint Cap Required)
1	6500MXK220805DS1	5	6500 MX 2200mm x 800mm Door Stiffener
1	6500MXK220805FG	0	6500 MXD 2200mm x 800mm Front Gasket
1	6500MXK220805F-P	0	6500 MXD 2200mm x 800mm Front Part

Parts List

Tél: (450) 979-4373 Fax: (450) 979-4626 www.exmweb.com		Flatness Aplatissement Max 3.0mm Projection
Customer Client	Date	Date 25-Feb-15
Drawn By Dessiné Par	BoxCad: BoxCad	
Material Matière	14 Ga Cold Rolled A1008 CS Type B	
Color Couleur	Light Grey RAL7035	Finish Fini Textured
Description	6500 MXD 2200mm x 800mm Front	
Part Number Numéro Pièce	Rev. 0	16 / 18
6500MXK220805F		

This drawing is confidential and must not be reproduced or used without the consent of EXM

Ce dessin est confidentiel et ne doit pas être reproduit ou utilisé sans le consentement de EXM



TOP

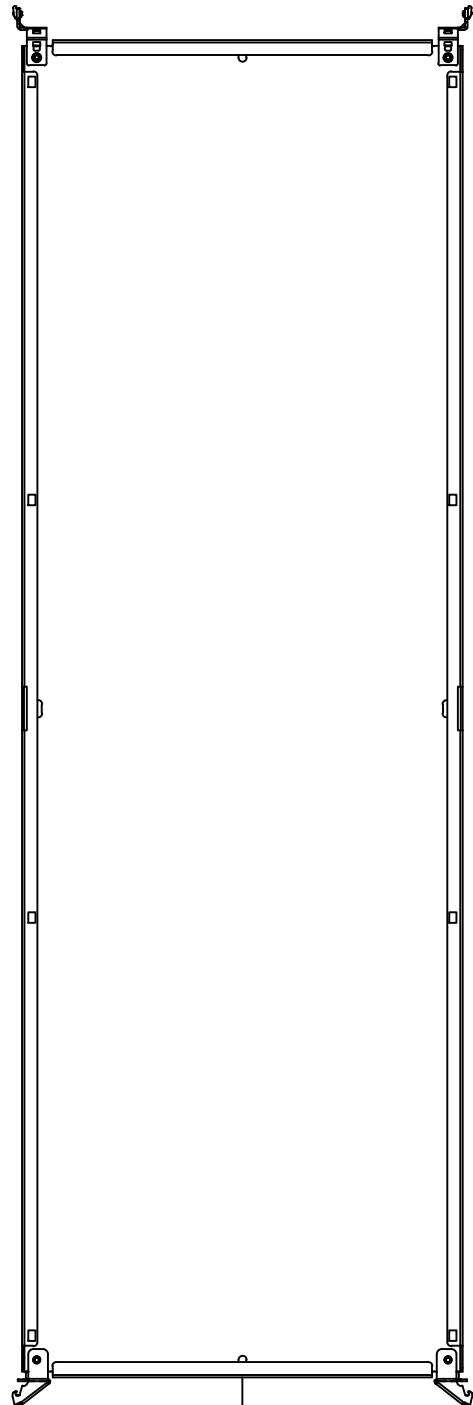

BACK



BOTTOM

0.0
26.0

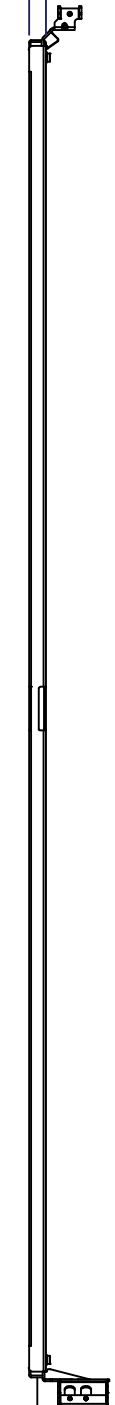

LEFT

0.0
685.0

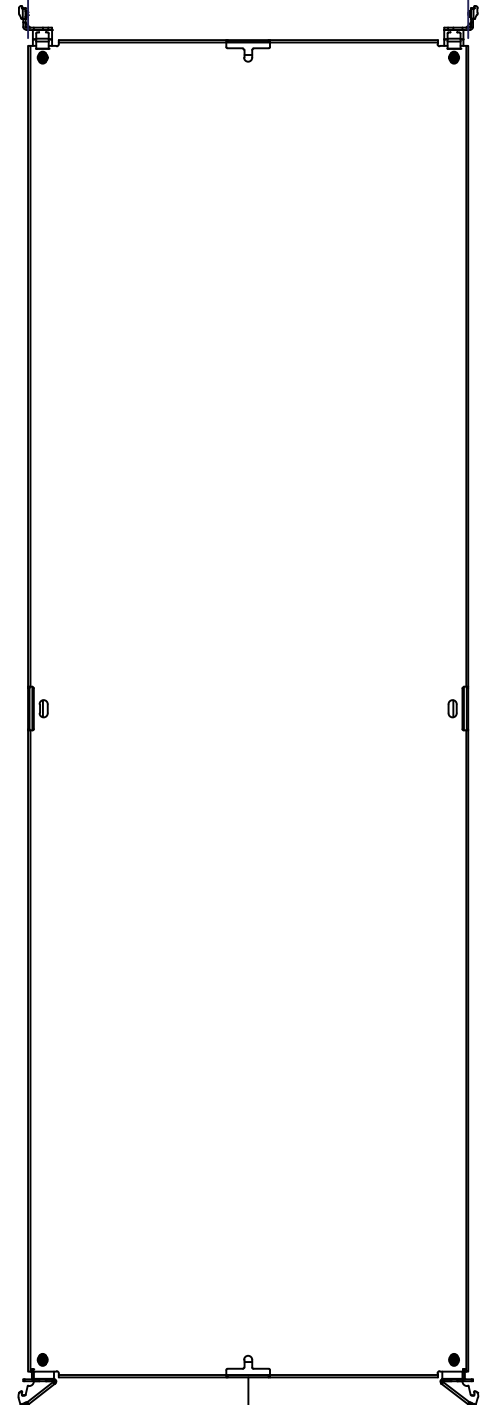

FRONT

2080.0

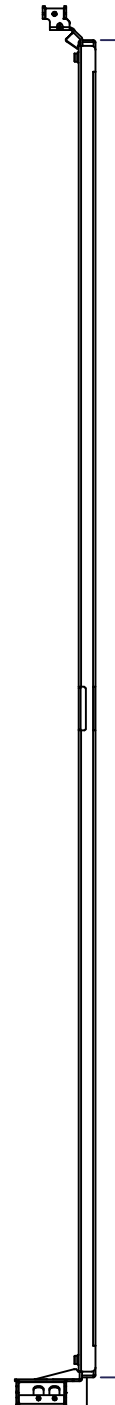

RIGHT

0.0

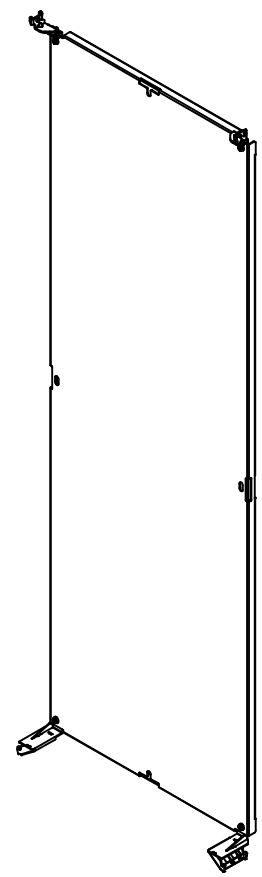

Isometric View

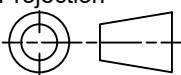

No.	Revisions	Date	By/Par

 Tél: (450) 979-4373 Fax: (450) 979-4626 www.exmweb.com		Flatness Aplatissement Max 3.0mm Projection 
Customer Client	Date	
Drawn By Dessiné Par	BoxCad: BoxCad	Date 25-Feb-15
Material Matière	12 Ga Galvanized (2.5mm)	
Color Couleur	Unpainted	Finish Fini Unpainted
Description 6500 MXM 2200mm x 800mm Back Inner Panel		Detail Rev.
Part Number Numéro Pièce	Rev. 0	17 18

SEE BILL OF MATERIAL ON LAST PAGE

6500MXK220805BIP

This drawing is confidential and must not be reproduced or used without the consent of EXM

Ce dessin est confidentiel et ne doit pas être reproduit ou utilisé sans le consentement de EXM

No.	Revisions	Date	By/Par

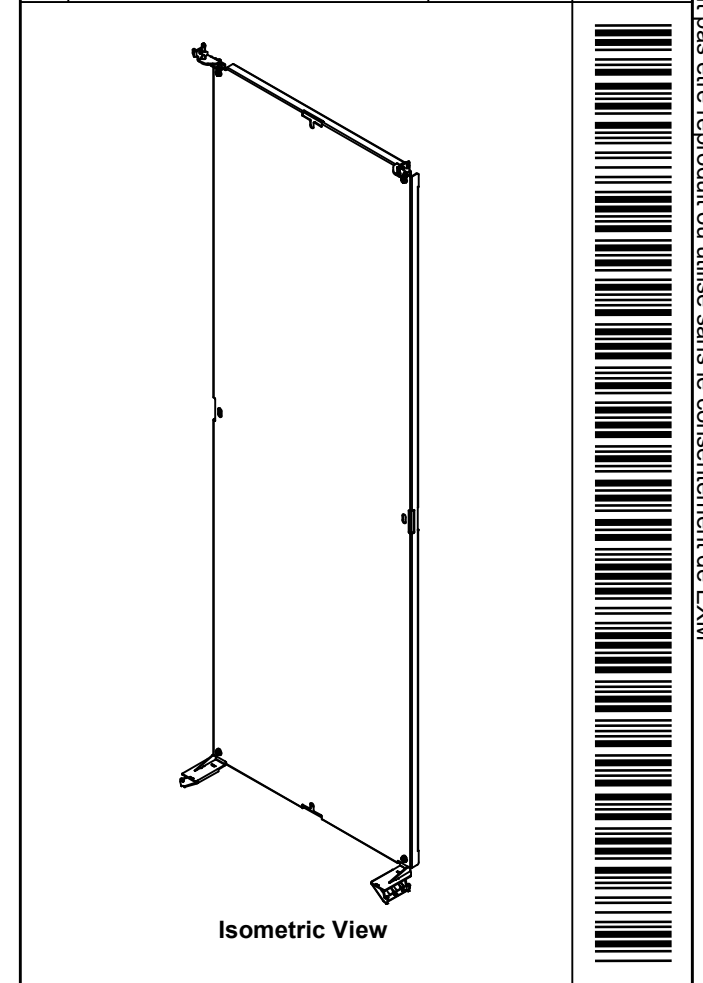

Tél: (450) 979-4373 Fax: (450) 979-4626 www.exmweb.com		Flatness Aplatissement	
		Max 3.0mm Projection	
Customer Client		Date	
Drawn By Dessiné Par		Date	
Material Matière		12 Ga Galvanized (2.5mm)	
Color Couleur		Finish Fini	
Unpainted		Unpainted	
Description			Detail Rev.
6500 MXM 2200mm x 800mm Back Inner Panel			
Part Number Numéro Pièce		Rev.	18
6500MXK220805BIP		0	18

Qty	Part Number	Rev	Description
1	STK-A-49005	5	6500 MXM - Bottom Inner Panel Support Assembly (Right)
1	STK-A-49000	5	6500 MXM - Bottom Inner Panel Support Assembly (Left)
1	STK-A-49015	0	6500MXM - Top Inner Panel Support Kit (Right)
1	STK-A-49010	0	6500MXM - Top Inner Panel Support Kit (Left)
1	6500MXK220805BIP-P	0	6500 MXM 2200mm x 800mm Back Inner Panel Part
Parts List			