

This drawing is confidential and must not be reproduced or used without the consent of EXM

Ce dessin est confidentiel et ne doit pas être reproduit ou utilisé sans le consentement de EXM

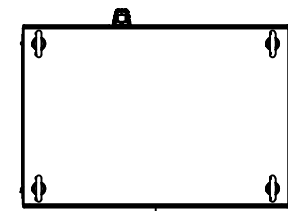

TOP

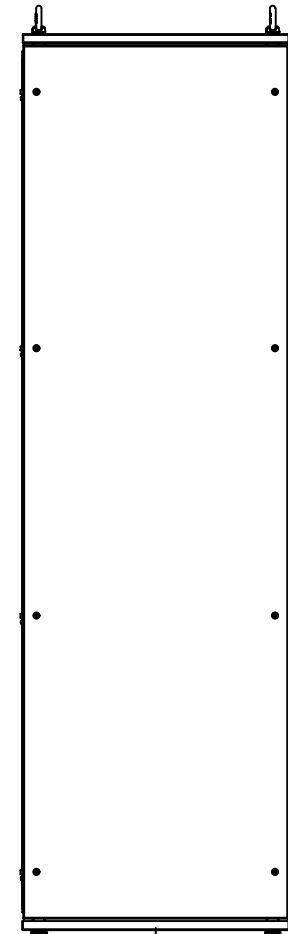

BACK

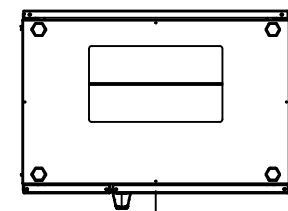

BOTTOM

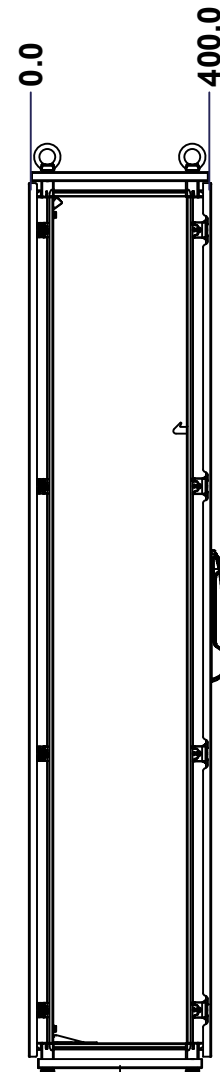

LEFT

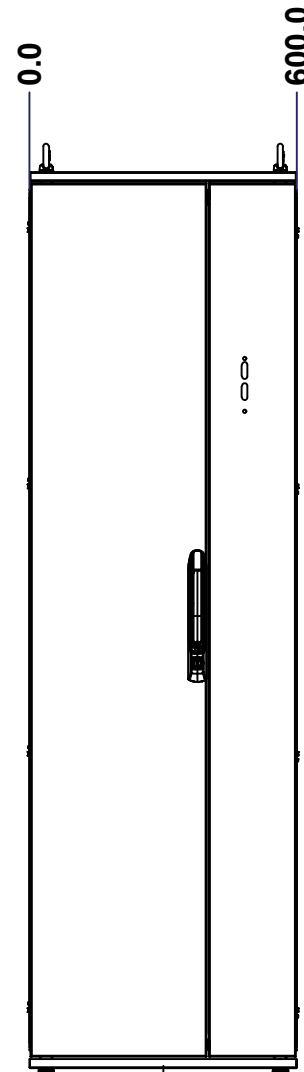

FRONT

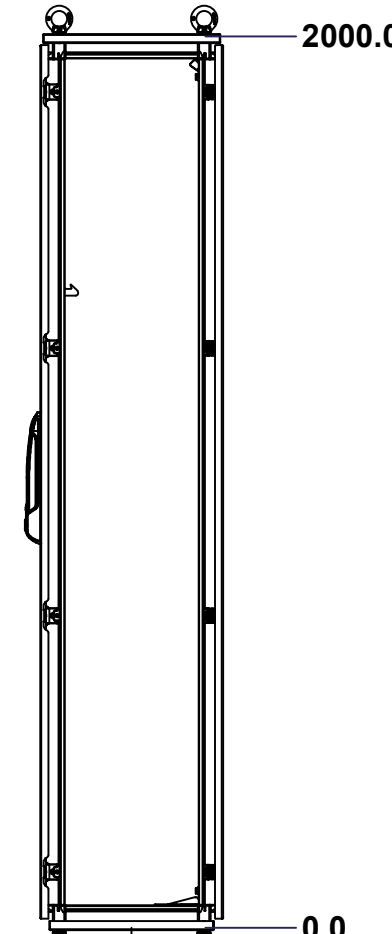

RIGHT

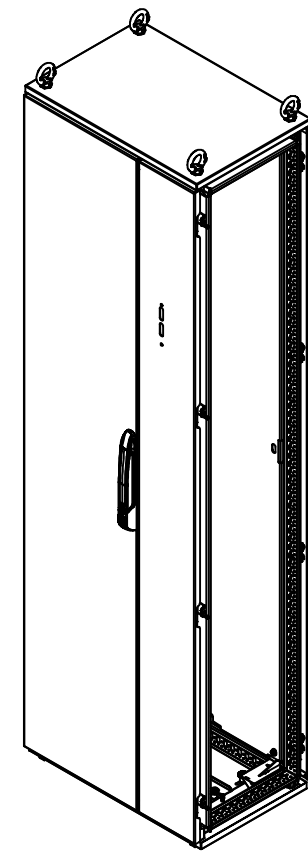

Isometric View

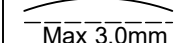
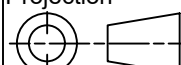

No.	Revisions	Date	By/Par

 Tél: (450) 979-4373 Fax: (450) 979-4626 www.exmweb.com		Flatness Aplatissement  Max 3.0mm Projection 
Customer Client		Date
Drawn By Dessiné Par	BoxCad: BoxCad	Date 09-Mar-15
Material Matière	See Part List	
Color Couleur	See Part List	Finish Fini See Part List
Description	Detail Rev.	
6500MX 2000mm x 600mm x 400mm Assembly		
Part Number Numéro Pièce	Rev.	1
6500MXU200604	0	18

SEE BILL OF MATERIAL ON LAST PAGE

This drawing is confidential and must not be reproduced or used without the consent of EXM

Ce dessin est confidentiel et ne doit pas être reproduit ou utilisé sans le consentement de EXM

No.	Revisions	Date	By/Par

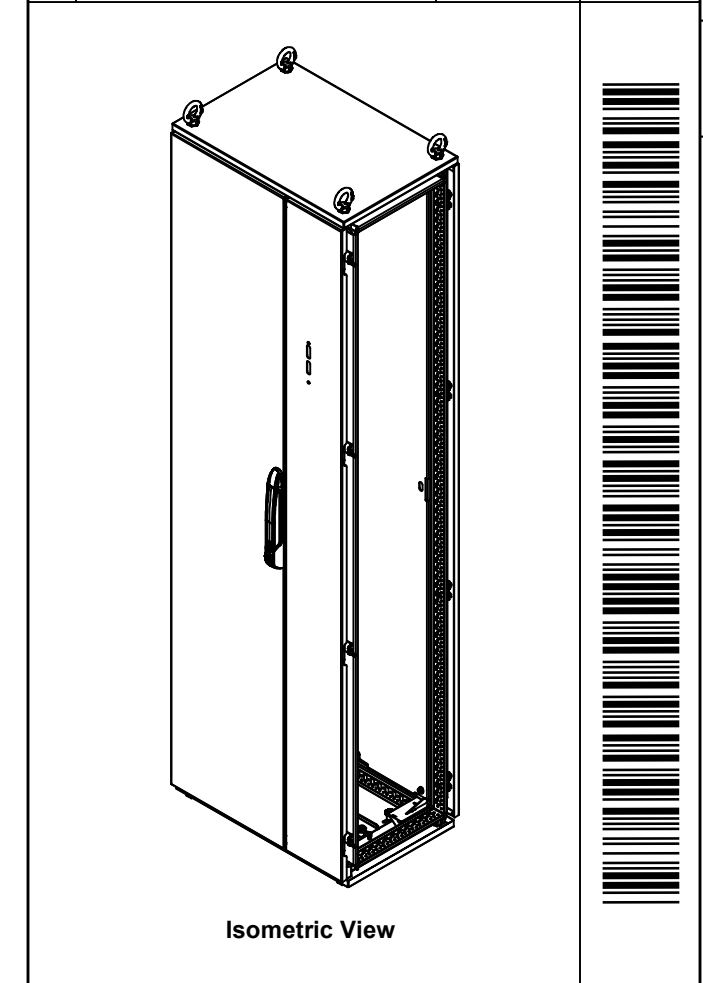

Tél: (450) 979-4373 Fax: (450) 979-4626 www.exmweb.com		Flatness Aplatissement Max 3.0mm
		Projection
Customer Client	Date	
Drawn By Dessiné Par	BoxCad: BoxCad	Date 09-Mar-15
Material Matière	See Part List	
Color Couleur	See Part List	Finish Fini See Part List
Description 6500MX 2000mm x 600mm x 400mm Assembly		Detail Rev.
Part Number Numéro Pièce 6500MXU200604		Rev. 2 0 / 18

Qty	Part Number	Rev	Description
1	6500MXU200604BIP	0	6500 MXM 2000mm x 600mm Back Inner Panel
1	6500MXU200604F	0	6500 MXDU 2000mm x 600mm Front
1	6500MXU200604B	0	6500 MXR 2000mm x 600mm Back
1	6500MXU200604BT	0	6500 MXB 600mm x 400mm Bottom
1	6500MXU200604T	0	6500 MXT 600mm x 400mm Top
1	6500MXU200604FR	0	6500 MX 2000mm x 600mm x 400mm Frame
Parts List			

This drawing is confidential and must not be reproduced or used without the consent of EXM

Ce dessin est confidentiel et ne doit pas être reproduit ou utilisé sans le consentement de EXM

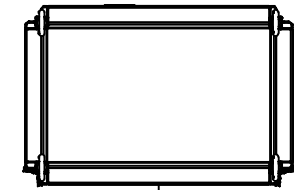

TOP

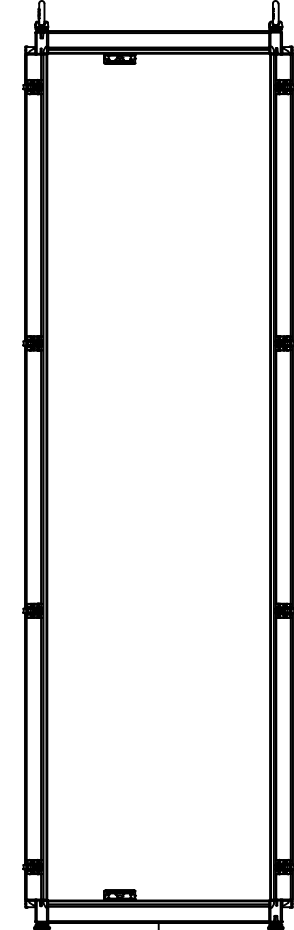

BACK

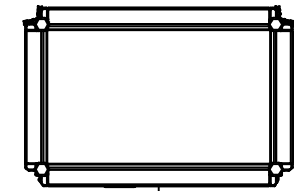

BOTTOM

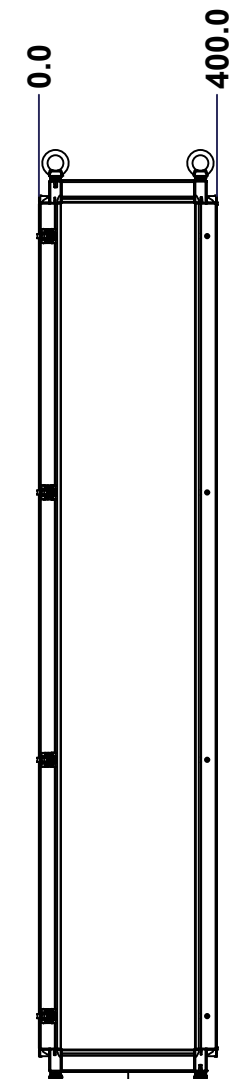

LEFT

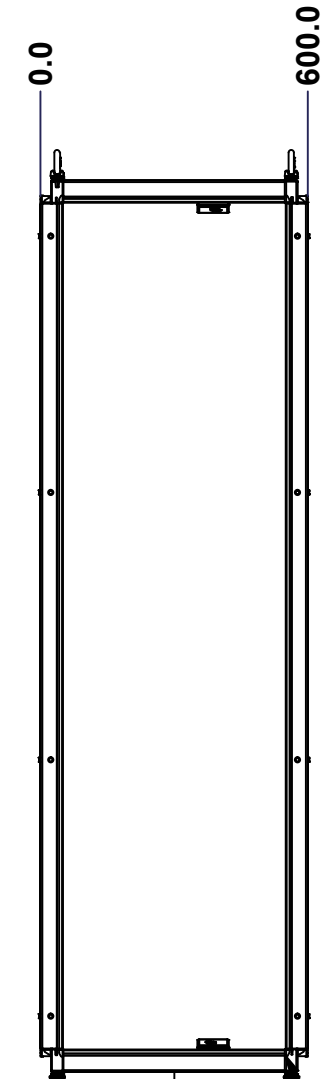

FRONT

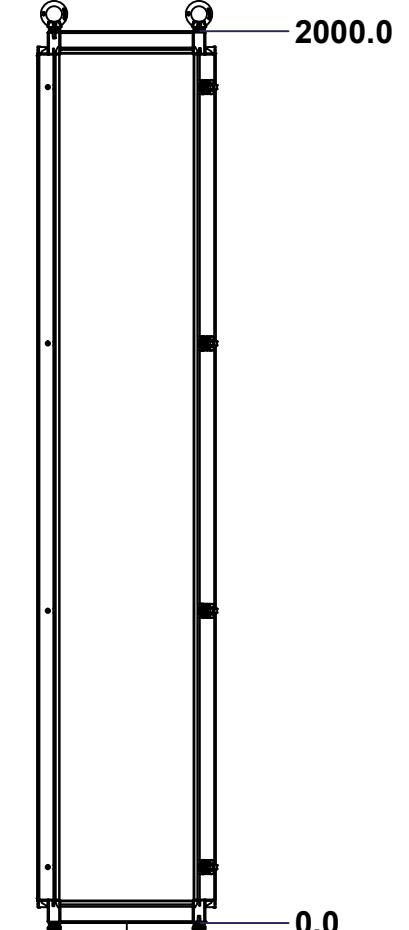

RIGHT

Grind excess weld off corner(s)

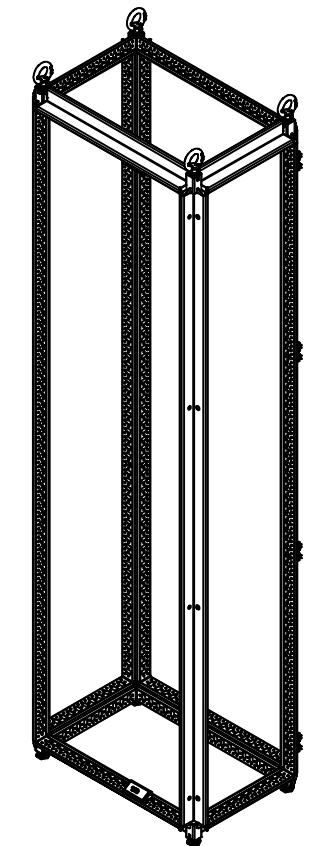

Isometric View



No.	Revisions	Date	By/Par



Tél: (450) 979-4373
 Fax: (450) 979-4626
www.exmweb.com

Flatness
Aplatissement
Max 3.0mm
Projection

Customer Client	Date
Drawn By Dessiné Par BoxCad: BoxCad	Date 09-Mar-15
Material Matière 16 Ga Electro-Galvanized (1.4mm)	

Color Couleur Iron Grey RAL7011	Finish Fini Textured
------------------------------------	-------------------------

Description 6500 MX 2000mm x 600mm x 400mm Frame	Detail Rev.
--	-------------

Part Number Numéro Pièce 6500MXU200604FR	Rev. 0	3 18
---	------------------	---------

SEE BILL OF MATERIAL ON LAST PAGE

This drawing is confidential and must not be reproduced or used without the consent of EXM

Ce dessin est confidentiel et ne doit pas être reproduit ou utilisé sans le consentement de EXM

No.	Revisions	Date	By/Par

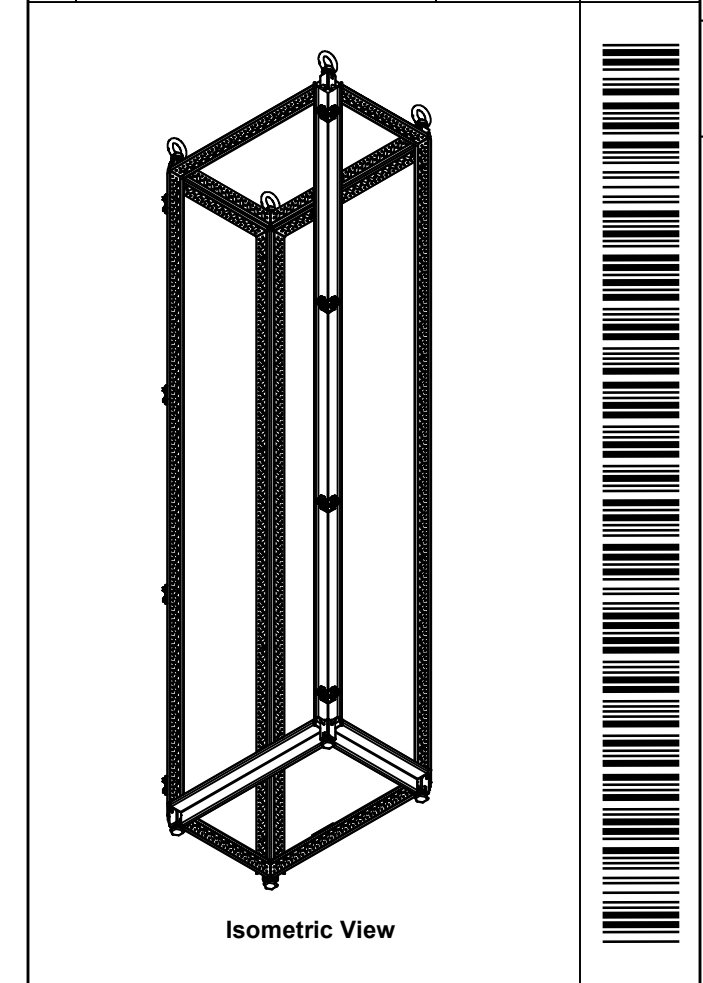

1	STK-P-03810ST	0	Powder Paint (Iron Grey /Sand Textured)
4	STK-Q-47250-06	6	6500 MX 600mm Horizontal Frame Post Part
4	STK-Q-47250-04	6	6500 MX 400mm Horizontal Frame Post Part
2	STK-Q-05020	5	M5 x 8mm Thread Rolling Screw
2	STK-A-74730	2	6500 MX - Flange Door Sealing Block
16	STK-Q-77120	1	6500MX-Frame Rubber Plug
8	STK-A-70580	9	Mtrx Bracket
8	STK-Q-00610	3	M16 x 30.0mm Bolt
8	STK-A-49448	6	6500 MX - Frame Sheet Metal Corner Assembly
4	STK-Q-49500	3	M12 Eye Bolt (0.34T)
4	STK-Q-61110	0	M12 Feet Leveler
4	STK-Q-47251-20	6	6500 MX 2000mm Vertical Frame Post Part
Qty	Part Number	Rev	Description
Parts List			

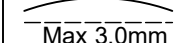
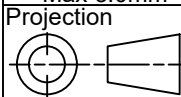
 Tél: (450) 979-4373 Fax: (450) 979-4626 www.exmweb.com		Flatness Aplatissement  Max 3.0mm Projection 
Customer Client	Date	
Drawn By Dessiné Par	BoxCad: BoxCad	Date 09-Mar-15
Material Matière	16 Ga Electro-Galvanized (1.4mm)	
Color Couleur	Iron Grey RAL7011	Finish Fini Textured
Description	Detail Rev.	
6500 MX 2000mm x 600mm x 400mm Frame		
Part Number Numéro Pièce	Rev.	4
6500MXU200604FR	0	18

This drawing is confidential and must not be reproduced or used without the consent of EXM

Ce dessin est confidentiel et ne doit pas être reproduit ou utilisé sans le consentement de EXM

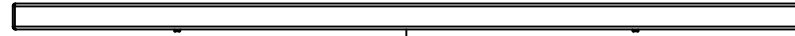

TOP

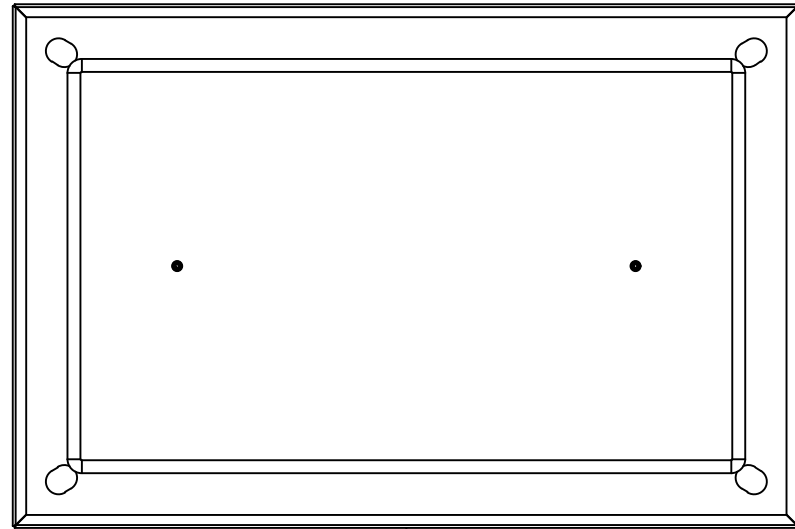

BACK

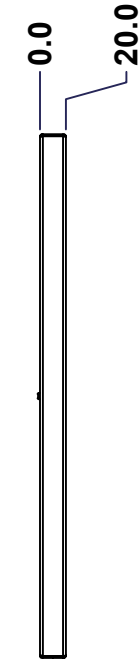

LEFT

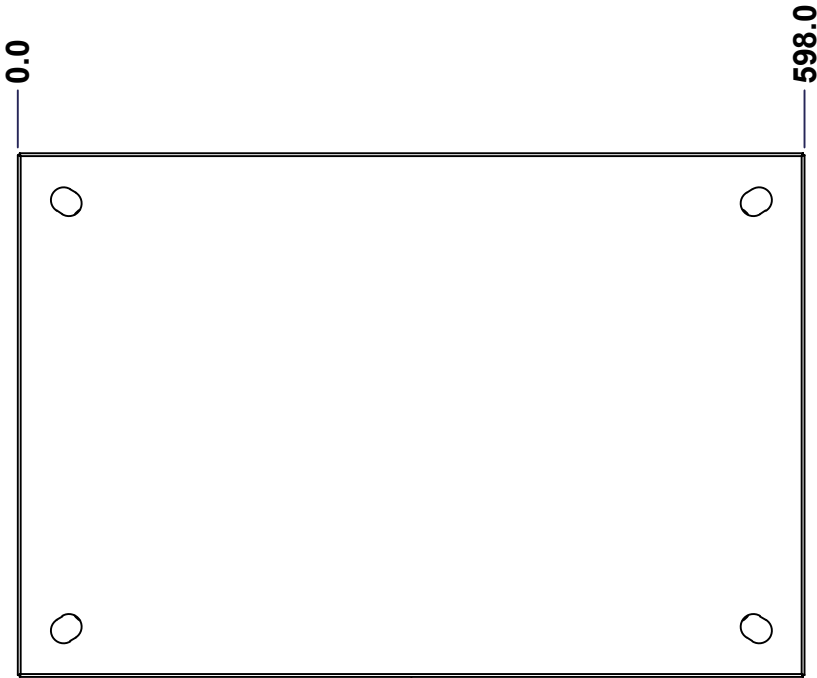

FRONT

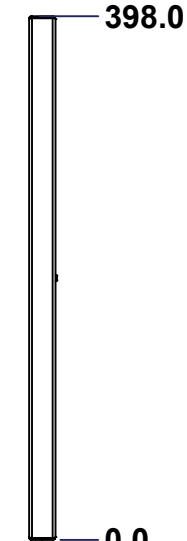

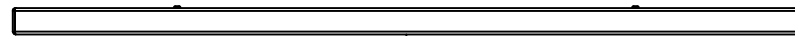

RIGHT

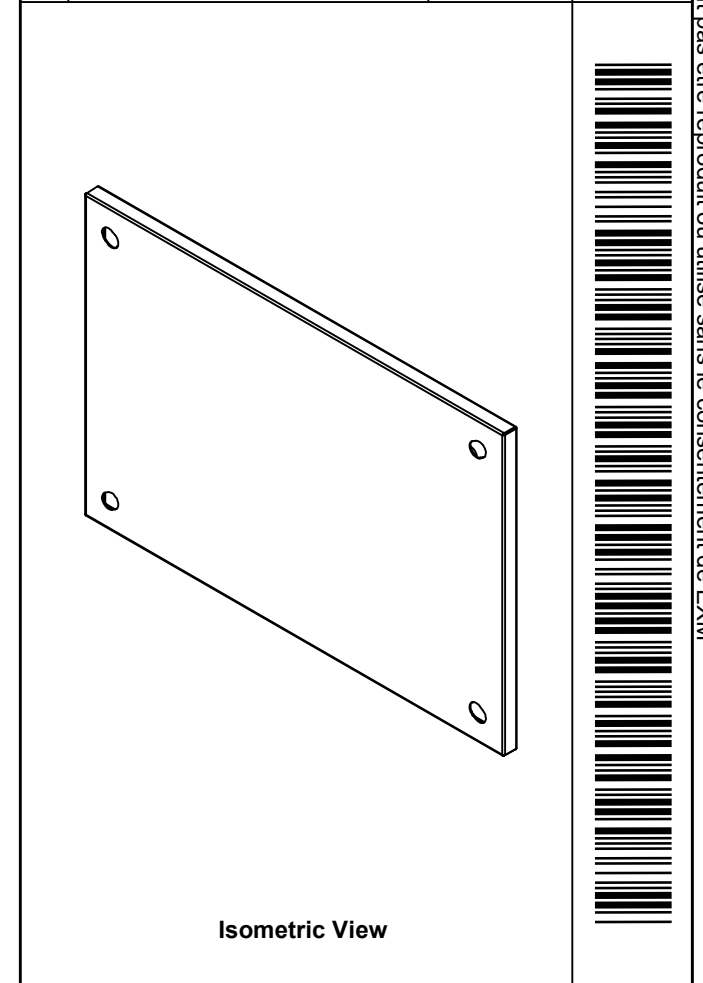

BOTTOM

No.	Revisions	Date	By/Par

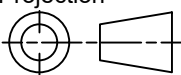

 Tél: (450) 979-4373 Fax: (450) 979-4626 www.exmweb.com		Flatness Aplatissement Max 3.0mm Projection 
Customer Client	Date	
Drawn By Dessiné Par	BoxCad: BoxCad	Date 09-Mar-15
Material Matière	16 Ga Cold Rolled A1008 CS Type B	
Color Couleur	Iron Grey RAL7011	Finish Fini Textured
Description	Detail Rev.	
6500 MXT 600mm x 400mm Top		
Part Number Numéro Pièce	Rev.	5
6500MXU200604T	0	18

Use gasket program path 6500 MX > 6500 MXT

SEE BILL OF MATERIAL ON LAST PAGE

This drawing is confidential and must not be reproduced or used without the consent of EXM

Ce dessin est confidentiel et ne doit pas être reproduit ou utilisé sans le consentement de EXM

STANDARD FEATURES ARE NOT LISTED IN THIS HOLE TABLE			
HOLE TABLE - FRONT VIEW (CUSTOM FEATURE ONLY)			
CUT-OUT	XDIM	YDIM	DESCRIPTION
1	125.0	199.0	GND STUD M6 x 18mm (Inside)
2	473.0	199.0	GND STUD M6 x 18mm (Inside)



FRONT

Use bending program path 6500 MX > 6500 MXT

	Description	Status
	6500 MXT 600mm x 400mm Top	(NULL)
	Part Number Numéro Pièce	Rev.
	6500MXU200604T	0 / 6
		18

This drawing is confidential and must not be reproduced or used without the consent of EXM

Ce dessin est confidentiel et ne doit pas être reproduit ou utilisé sans le consentement de EXM

No.	Revisions	Date	By/Par

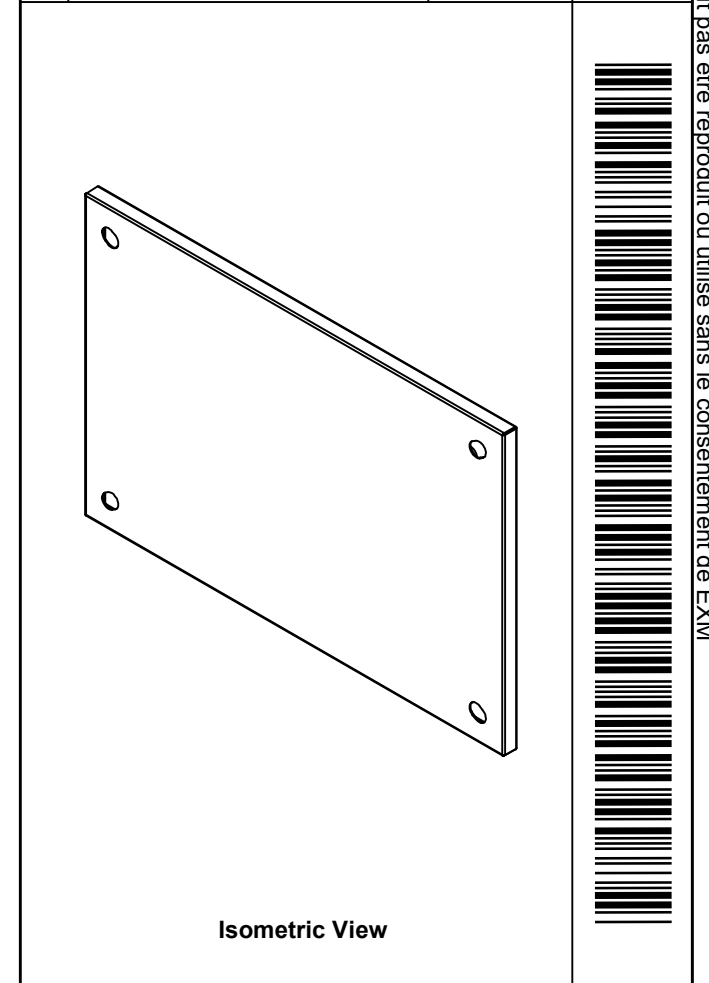

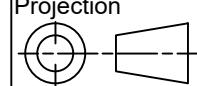
 Tél: (450) 979-4373 Fax: (450) 979-4626 www.exmweb.com		Flatness Aplatissement Max 3.0mm Projection 
Customer Client	Date	
Drawn By Dessiné Par	BoxCad: BoxCad	Date 09-Mar-15
Material Matière	16 Ga Cold Rolled A1008 CS Type B	
Color Couleur	Iron Grey RAL7011	Finish Fini Textured
Description		Detail Rev.
6500 MXT 600mm x 400mm Top		
Part Number Numéro Pièce		Rev. 7
6500MXU200604T		0 18

Qty	Part Number	Rev	Description
1	STK-P-03810ST	0	Powder Paint (Iron Grey /Sand Textured)
2	STK-Q-16055	1	M6 x 18mm Stud (No Paint Cap Required)
1	6500MXU200604TG	0	6500 MXT 600mm x 400mm Top Gasket
1	6500MXU200604T-P	0	6500 MXT 600mm x 400mm Top Part
Parts List			

This drawing is confidential and must not be reproduced or used without the consent of EXM

Ce dessin est confidentiel et ne doit pas être reproduit ou utilisé sans le consentement de EXM

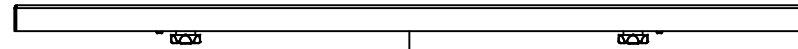

TOP

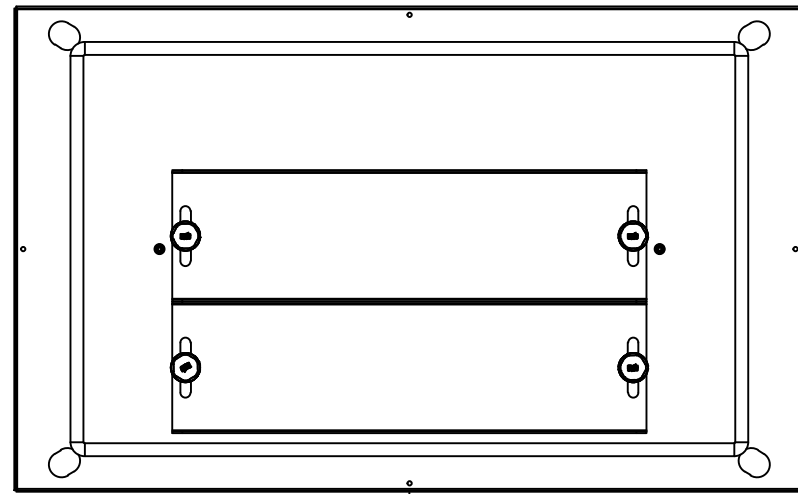

BACK

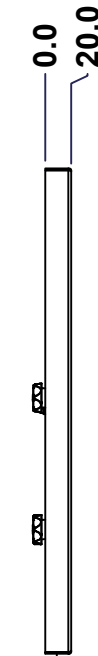

LEFT

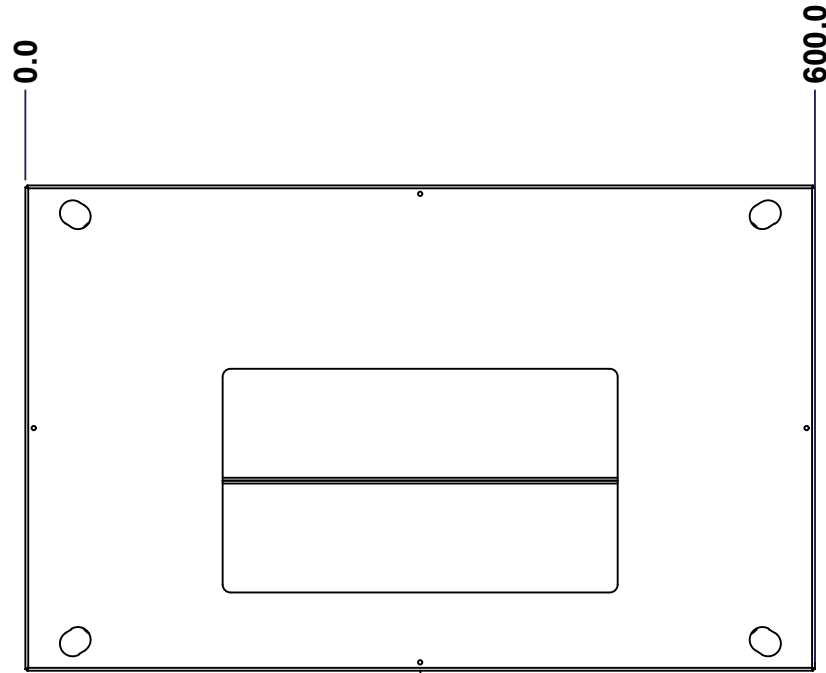

FRONT

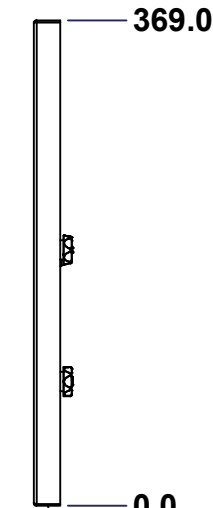

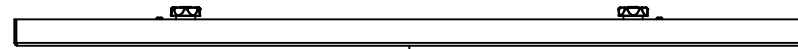

RIGHT

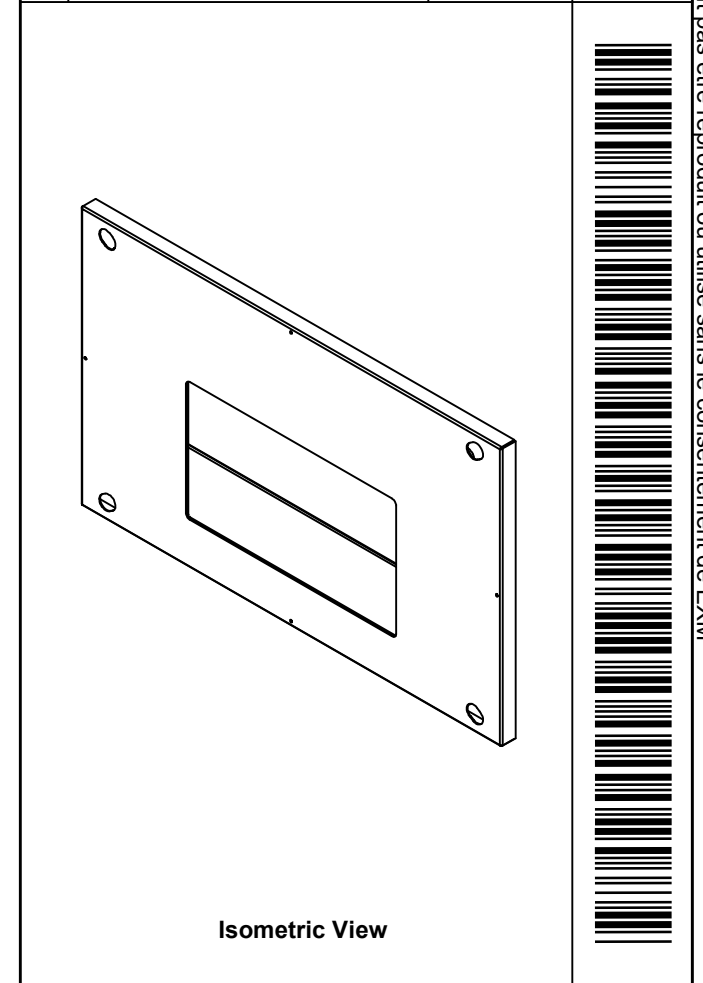

BOTTOM

No.	Revisions	Date	By/Par

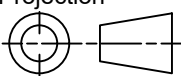

 Tél: (450) 979-4373 Fax: (450) 979-4626 www.exmweb.com		Flatness Aplatissement Max 3.0mm Projection 
Customer Client	Date	
Drawn By Dessiné Par	BoxCad: BoxCad	Date 09-Mar-15
Material Matière	16 Ga Cold Rolled A1008 CS Type B	
Color Couleur	Iron Grey RAL7011	Finish Fini Textured
Description	Detail Rev.	
6500 MXB 600mm x 400mm Bottom		
Part Number Numéro Pièce	Rev.	8
6500MXU200604BT	0	18

Use gasket program path 6500 MX > 6500MXB

SEE BILL OF MATERIAL ON LAST PAGE

This drawing is confidential and must not be reproduced or used without the consent of EXM

Ce dessin est confidentiel et ne doit pas être reproduit ou utilisé sans le consentement de EXM

STANDARD FEATURES ARE NOT LISTED IN THIS HOLE TABLE

HOLE TABLE - FRONT VIEW (CUSTOM FEATURE ONLY)

CUT-OUT	XDIM	YDIM	DESCRIPTION
1	110.0	184.5	GND STUD M6 x 18mm (Inside)
2	490.0	184.5	GND STUD M6 x 18mm (Inside)
3	130.0	194.5	GP STUD M6 x 18mm (Inside)
4	470.0	194.5	GP STUD M6 x 18mm (Inside)
5	130.0	94.5	GP STUD M6 x 18mm (Inside)
6	470.0	94.5	GP STUD M6 x 18mm (Inside)

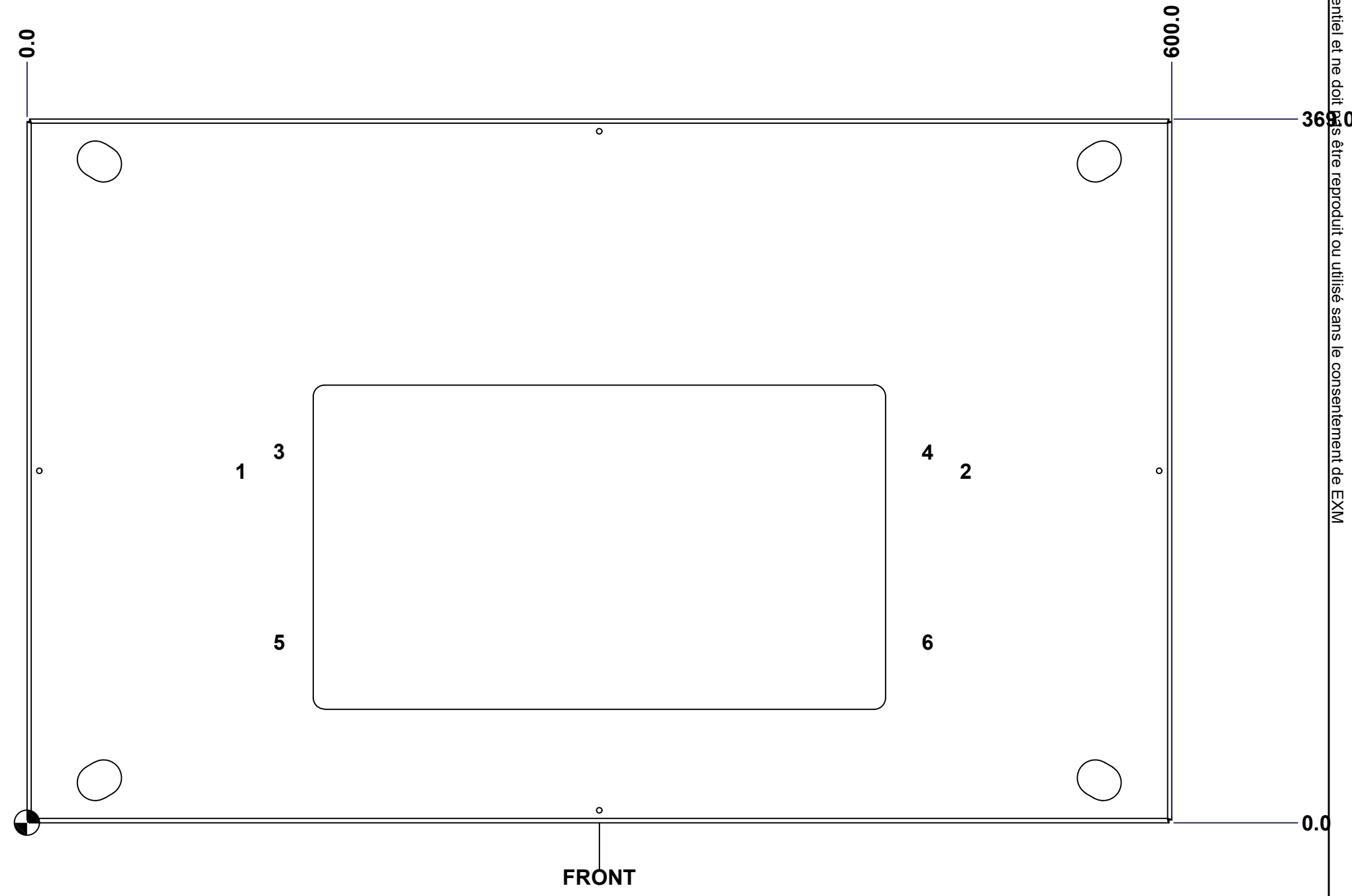

Use bending program path 6500 MX > 6500MXB

	Description 6500 MXB 600mm x 400mm Bottom	Status (NULL)
	Part Number Numéro Pièce 6500MXU200604BT	Rev. 9 0

This drawing is confidential and must not be reproduced or used without the consent of EXM

Ce dessin est confidentiel et ne doit pas être reproduit ou utilisé sans le consentement de EXM

No.	Revisions	Date	By/Par

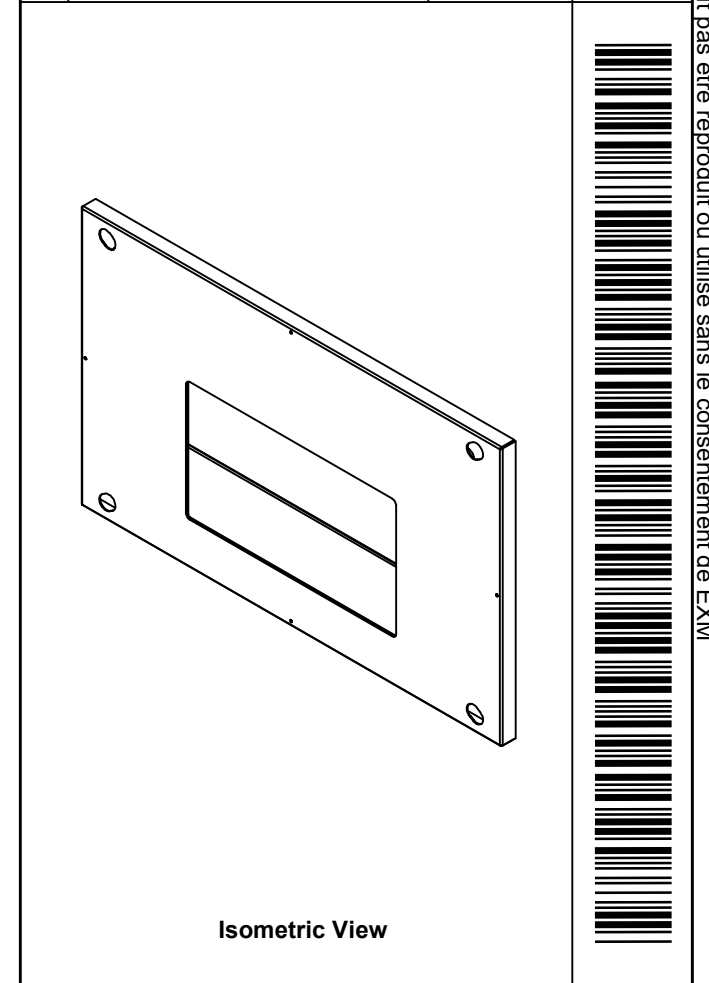



Tél: (450) 979-4373
Fax: (450) 979-4626
www.exmweb.com

Flatness
Aplatissement
Max 3.0mm

Projection



Customer Client	Date
Drawn By / Dessiné Par: BoxCad: BoxCad	Date: 09-Mar-15

Material / Matière: 16 Ga Cold Rolled A1008 CS Type B

Color / Couleur: Iron Grey RAL7011	Finish / Fini: Textured
------------------------------------	-------------------------

Description: 6500 MXB 600mm x 400mm Bottom	Detail Rev.
--	-------------

Part Number / Numéro Pièce: 6500MXU200604BT	Rev. / Révis: 0	10	18
--	------------------------	----	----

Qty	Part Number	Rev	Description
1	STK-P-03810ST	0	Powder Paint (Iron Grey /Sand Textured)
4	STK-Q-06001	0	Mtrx - Gland Plate M6 Plastic Thumb Nut
6	STK-Q-16055	1	M6 x 18mm Stud (No Paint Cap Required)
2	6500MXU200604GP100-P	0	6500 MXB 600mm Gland Plate Part (100mm)
1	6500MXU200604BTGPG	0	6500 MXB 600mm x 400mm Bottom Gland Plate Gasket
1	6500MXU200604BTG	0	6500 MXB 600mm x 400mm Bottom Gasket
1	6500MXU200604BT-P	0	6500 MXB 600mm x 400mm Bottom Part
Parts List			

This drawing is confidential and must not be reproduced or used without the consent of EXM

Ce dessin est confidentiel et ne doit pas être reproduit ou utilisé sans le consentement de EXM

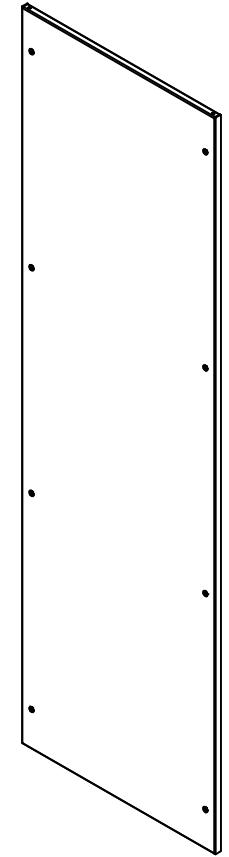
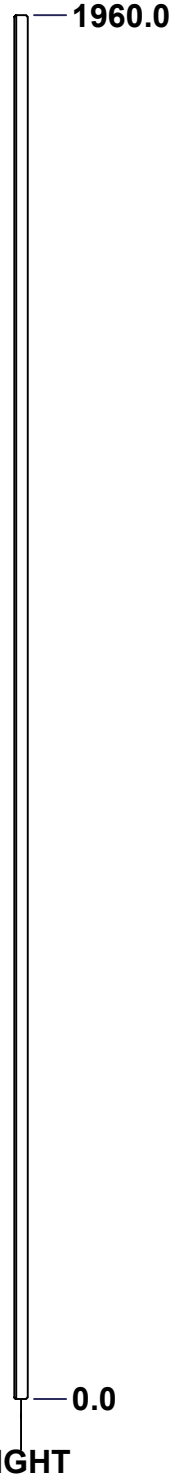
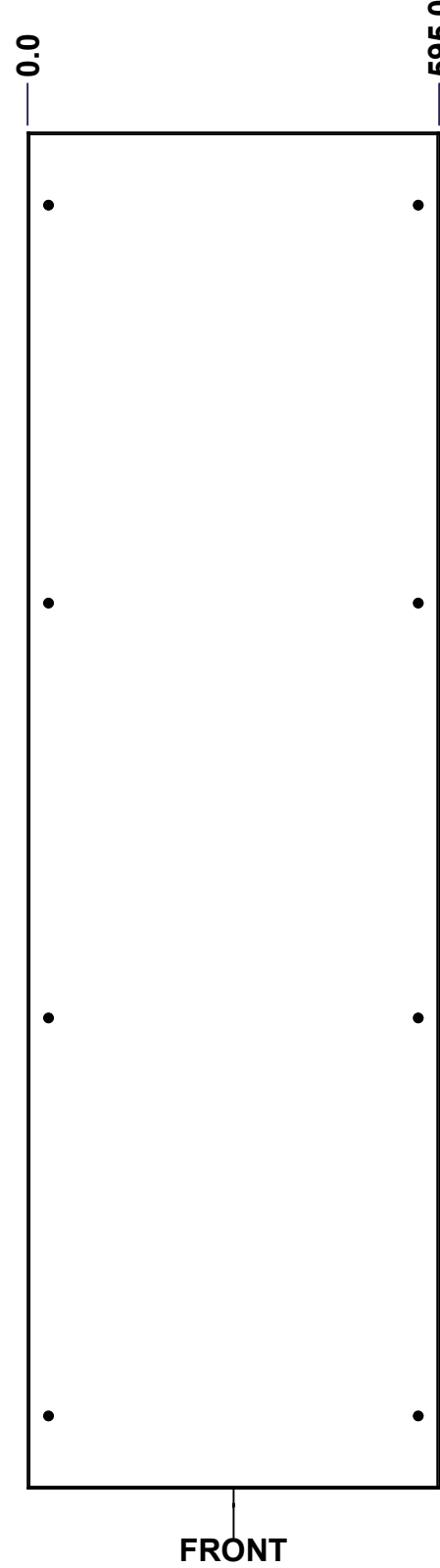
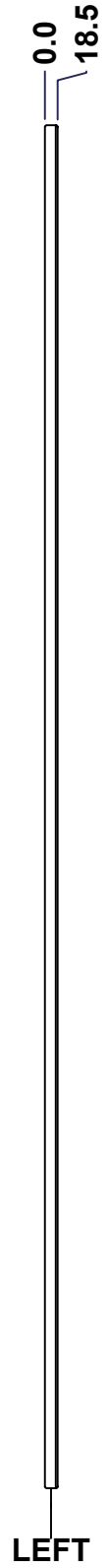
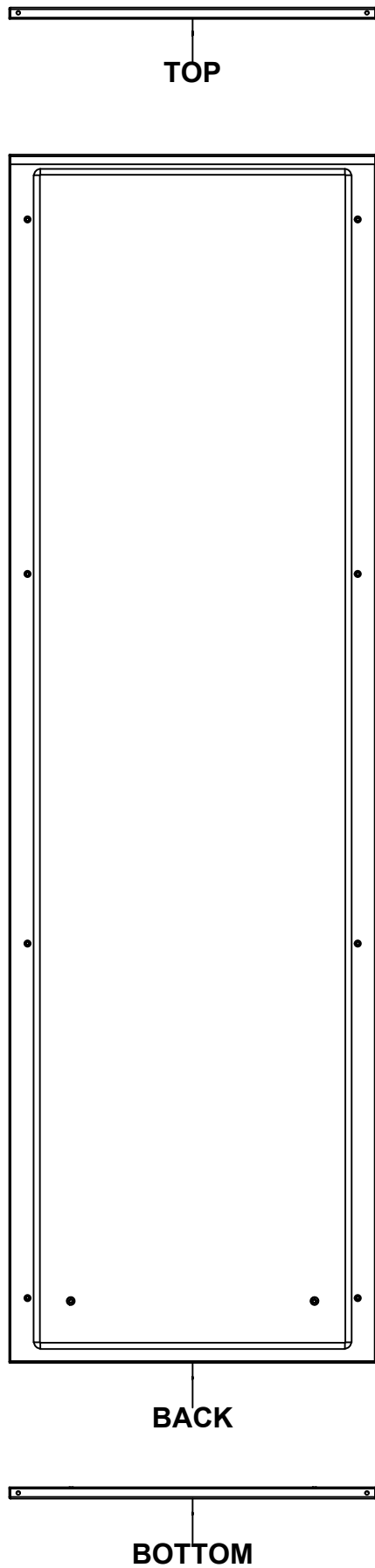

Isometric View

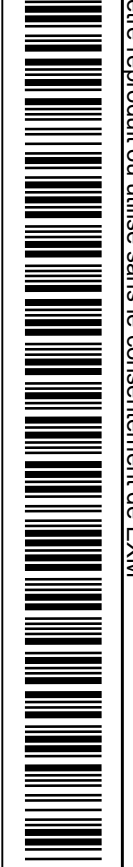

No.	Revisions	Date	By/Par

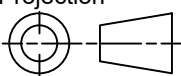
 Tél: (450) 979-4373 Fax: (450) 979-4626 www.exmweb.com		Flatness Aplatissement Max 3.0mm Projection 
Customer Client	Date	
Drawn By Dessiné Par	BoxCad: BoxCad	Date 09-Mar-15
Material Matière	14 Ga Cold Rolled A1008 CS Type B	
Color Couleur	Light Grey RAL7035	Finish Fini Textured
Description 6500 MXR 2000mm x 600mm Back		Detail Rev.
Part Number Numéro Pièce	Rev. 0	11 / 18

Use gasket program path 6500 MX > 6500 MXR

SEE BILL OF MATERIAL ON LAST PAGE

6500MXU200604B

This drawing is confidential and must not be reproduced or used without the consent of EXM

Ce dessin est confidentiel et ne doit pas être reproduit ou utilisé sans le consentement de EXM

STANDARD FEATURES ARE NOT LISTED IN THIS HOLE TABLE			
HOLE TABLE - FRONT VIEW (CUSTOM FEATURE ONLY)			
CUT-OUT	XDIM	YDIM	DESCRIPTION
1	100.0	100.0	GND STUD M6 x 16mm (Inside)
2	495.0	100.0	GND STUD M6 x 16mm (Inside)

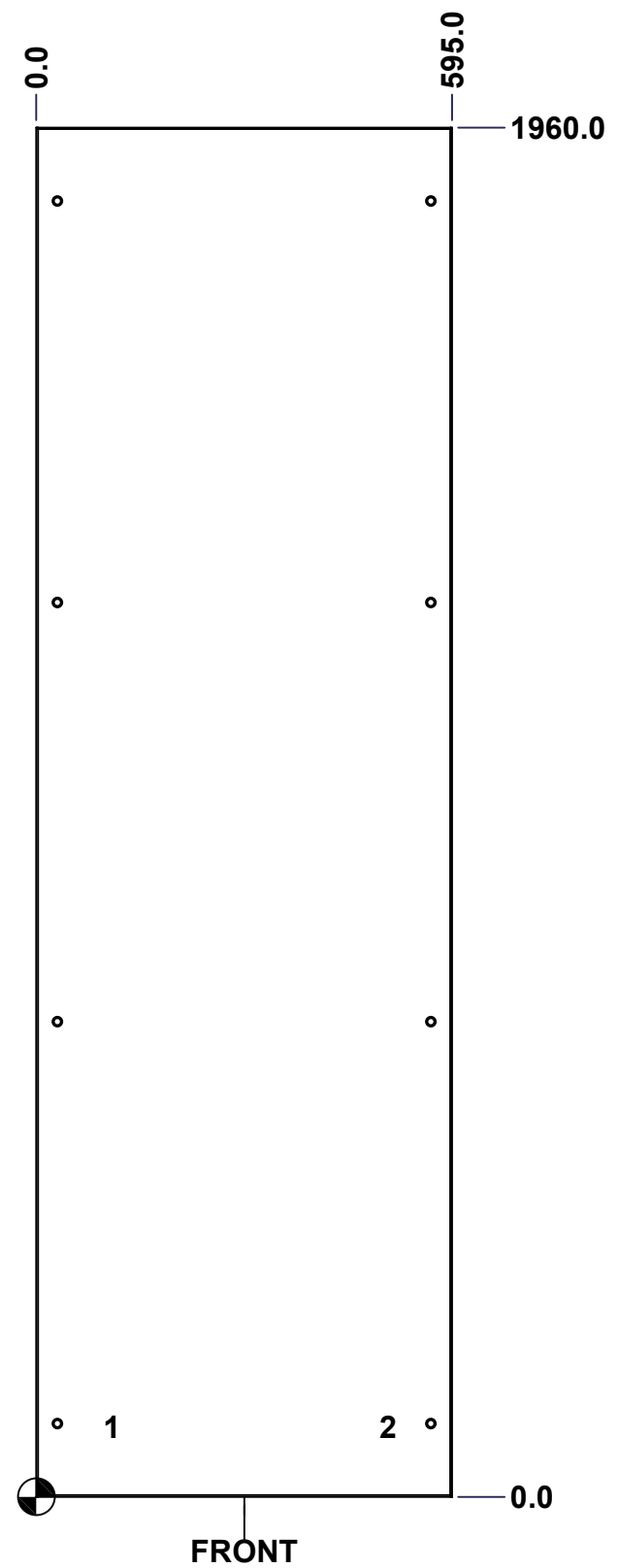

Use bending program path 6500 MX > 6500 MXR

	Description	Status
	6500 MXR 2000mm x 600mm Back	(NULL)
	Part Number Numéro Pièce	Rev.
	6500MXU200604B	0
		12
		18

This drawing is confidential and must not be reproduced or used without the consent of EXM

Ce dessin est confidentiel et ne doit pas être reproduit ou utilisé sans le consentement de EXM

No.	Revisions	Date	By/Par

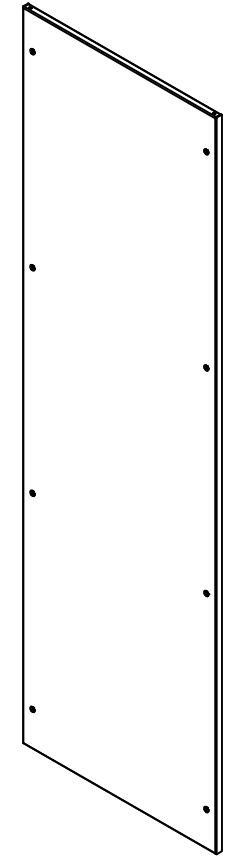

Isometric View

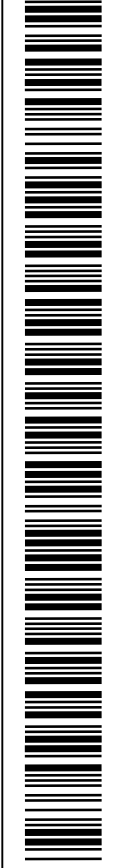

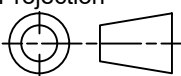
		Tél: (450) 979-4373 Fax: (450) 979-4626 www.exmweb.com		Flatness Aplatissement Max 3.0mm	
Customer Client		Date		Projection 	
Drawn By Dessiné Par		BoxCad: BoxCad		Date 09-Mar-15	
Material Matière		14 Ga Cold Rolled A1008 CS Type B			
Color Couleur		Light Grey RAL7035		Finish Fini Textured	
Description 6500 MXR 2000mm x 600mm Back				Detail Rev.	
Part Number Numéro Pièce 6500MXU200604B				Rev. 13 0	

Qty	Part Number	Rev	Description
1	STK-P-03820R	0	Powder Paint (Light Grey / Rough Textured)
1	6500MXU200604BG	0	6500 MXR 2000mm x 600mm Back Gasket
8	STK-Q-03071	0	M6 x 16mm Machine Screw
2	STK-Q-16080	0	Ground Stud M6 x 16mm Steel
1	6500MXU200604B-P	0	6500 MXR 2000mm x 600mm Back Part
Parts List			

This drawing is confidential and must not be reproduced or used without the consent of EXM

Ce dessin est confidentiel et ne doit pas être reproduit ou utilisé sans le consentement de EXM

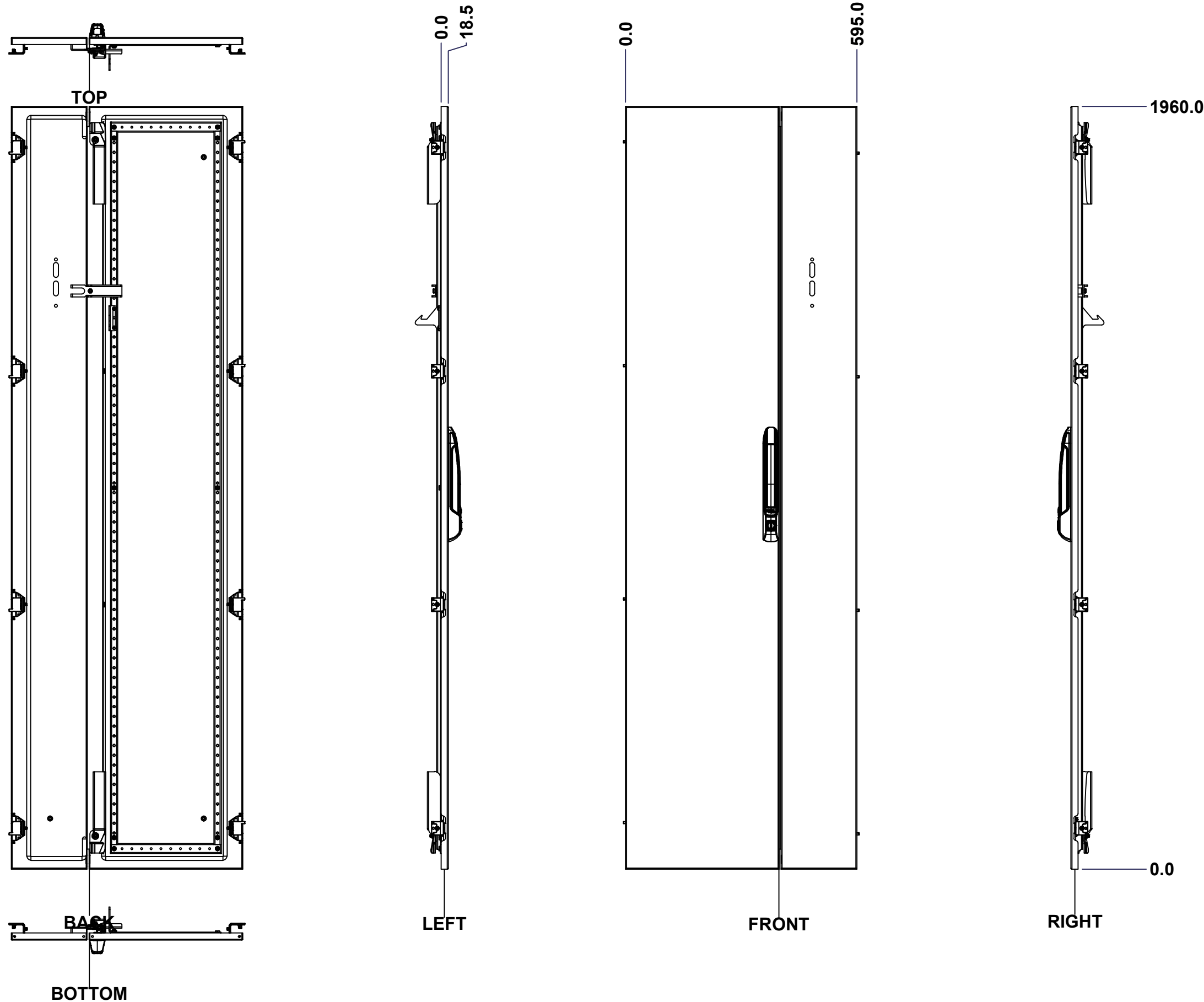

No.	Revisions	Date	By/Par

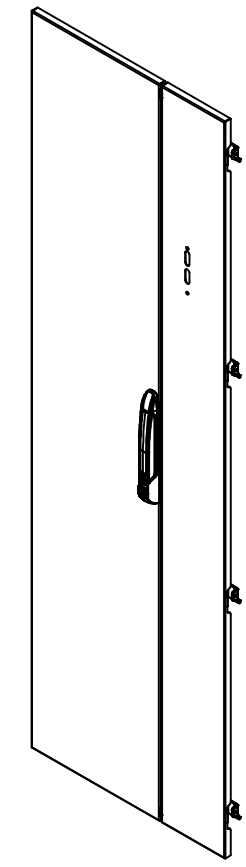

Isometric View

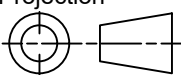

 Tél: (450) 979-4373 Fax: (450) 979-4626 www.exmweb.com		Flatness Aplatissement Max 3.0mm Projection 
Customer Client	Date	
Drawn By Dessiné Par	BoxCad: BoxCad	Date 09-Mar-15
Material Matière	14 Ga Cold Rolled A1008 CS Type B	
Color Couleur	Light Grey RAL7035	Finish Fini Textured
Description	Detail Rev.	
6500 MXDU 2000mm x 600mm Front		
Part Number Numéro Pièce	Rev.	14
6500MXU200604F	0	18

Use gasket program path 6500 MX > 6500 MXDU

SEE BILL OF MATERIAL ON LAST PAGE

This drawing is confidential and must not be reproduced or used without the consent of EXM

Ce dessin est confidentiel et ne doit pas être reproduit ou utilisé sans le consentement de EXM

STANDARD FEATURES ARE NOT LISTED IN THIS HOLE TABLE			
HOLE TABLE - FRONT VIEW (CUSTOM FEATURE ONLY)			
CUT-OUT	XDIM	YDIM	DESCRIPTION
1	100.0	130.0	GND STUD M6 x 16mm (Inside)
2	100.0	1830.0	GND STUD M6 x 16mm (Inside)
3	495.0	130.0	GND STUD M6 x 16mm (Inside)
4	64.5	52.8	STIFF. STUD M6 x 18mm (Inside)
5	64.5	980.0	STIFF. STUD M6 x 18mm (Inside)
6	64.5	1907.2	STIFF. STUD M6 x 18mm (Inside)
7	64.5	1879.0	STIFF. STUD M6 x 18mm (Inside)
8	64.5	81.0	STIFF. STUD M6 x 18mm (Inside)
9	330.5	52.8	STIFF. STUD M6 x 18mm (Inside)
10	330.5	980.0	STIFF. STUD M6 x 18mm (Inside)
11	330.5	1907.2	STIFF. STUD M6 x 18mm (Inside)
12	330.5	1879.0	STIFF. STUD M6 x 18mm (Inside)
13	330.5	81.0	STIFF. STUD M6 x 18mm (Inside)
14	374.0	170.0	LARGE CBAR GUIDE (Inside)
15	374.0	1790.0	LARGE CBAR GUIDE (Inside)
16	374.0	730.0	LARGE CBAR GUIDE (Inside)
17	374.0	1230.0	LARGE CBAR GUIDE (Inside)

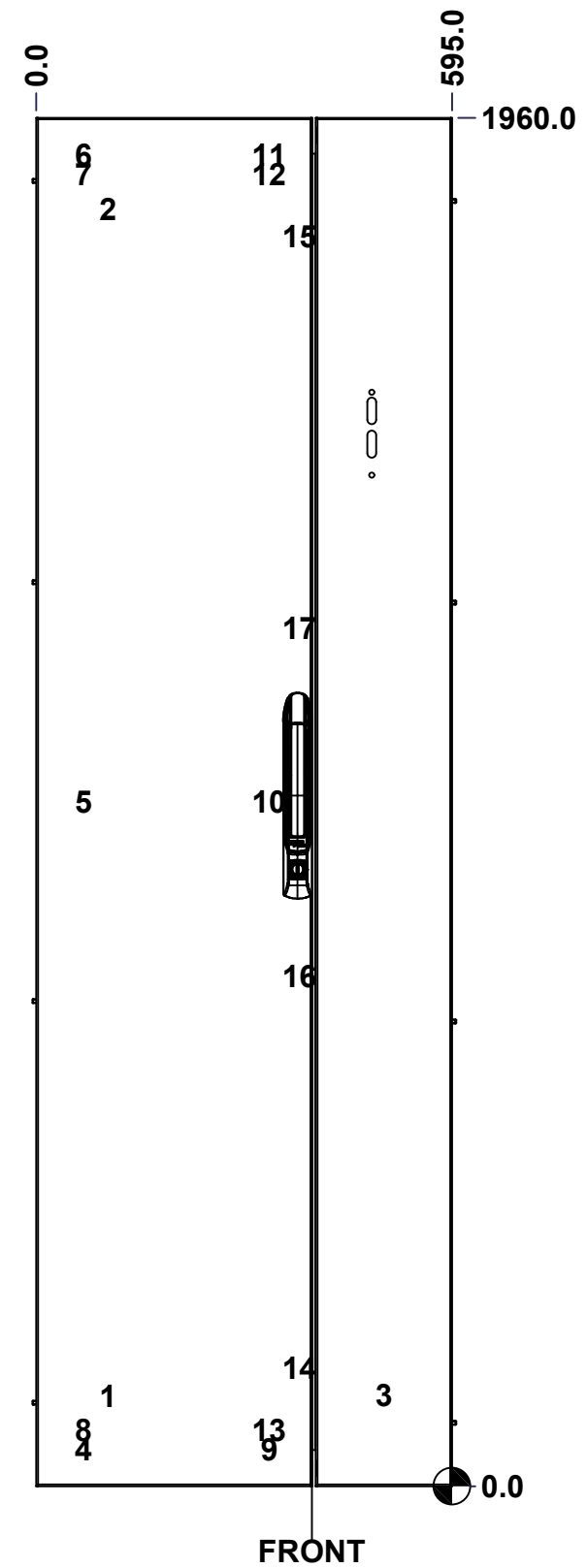

Use bending program path 6500 MX > 6500 MXDU

	Description 6500 MXDU 2000mm x 600mm Front	Status (NULL)
	Part Number Numéro Pièce 6500MXU200604F	Rev. 15 0

This drawing is confidential and must not be reproduced or used without the consent of EXM

Ce dessin est confidentiel et ne doit pas être reproduit ou utilisé sans le consentement de EXM

No.	Revisions	Date	By/Par

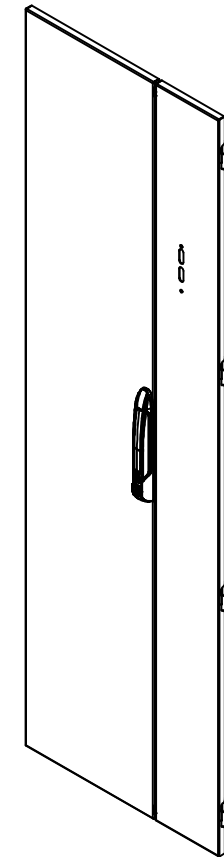

Isometric View



1	STK-P-03820R	0	Powder Paint (Light Grey / Rough Textured)
1	STK-A-51160	0	886PH2-SL - Pull Handle Lock - Assembly
1	STK-Q-45758	1	886 PH2 Pull Handle Bridge Part
4	STK-Q-16410	0	Guide Stud - Large (No Paint Cap Required)
4	STK-A-70586	3	Fixed Double Door Bracket Assembly
1	STK-Q-45662-20	1	6500 MX - Lower Closing Bar 2000mm
1	STK-Q-45661-20	1	6500 MX - Upper Closing Bar 2000mm
1	STK-Q-46650	3	6500 MXDU Disconnect Hook
8	STK-K-06810	7	6500 MX Hinge Assy
2	STK-Q-05020	5	M5 x 8mm Thread Rolling Screw
1	STK-Q-07220	0	M6 Nylon Insert Lock Nut
1	STK-Q-46750	4	6500 MXDU Disconnect Defeater
1	STK-K-10102	3	6500MX - Lock Handle Kit for Flange Door - Right
1	STK-K-10101	3	6500MX - Lock Handle Kit for Flange Door - Left
1	STK-Q-16030	0	Stud M6 x 10mm
2	STK-Q-16050	0	Stud M6 x 18mm
1	6500MXU200604F1G	0	6500 MXDU 2000mm x 600mm Front Gasket
1	6500MXU200604F1-P	0	6500 MXDU 2000mm x 600mm Front Part
10	STK-Q-16055	1	M6 x 18mm Stud (No Paint Cap Required)
3	STK-Q-16080	0.1.1	Ground Stud M6 x 16mm Steel
1	6500MXU200604DS1	5	6500 MX 2000mm x 600mm Door Stiffener
1	6500MXU200604FG	0	6500 MXDU 2000mm x 600mm Front Gasket
1	6500MXU200604F-P	0	6500 MXDU 2000mm x 600mm Front Part

Qty	Part Number	Rev.	Description
Parts List			

	Tél: (450) 979-4373 Fax: (450) 979-4626 www.exmweb.com	Flatness Aplatissement Max 3.0mm	
	Projection 	Customer Client	Date
Drawn By Dessiné Par	BoxCad: BoxCad	Date	09-Mar-15
Material Matière	14 Ga Cold Rolled A1008 CS Type B		
Color Couleur	Light Grey RAL7035	Finish Fini	Textured
Description	6500 MXDU 2000mm x 600mm Front		Detail Rev.
Part Number Numéro Pièce	6500MXU200604F		Rev. 16 0 18

This drawing is confidential and must not be reproduced or used without the consent of EXM

Ce dessin est confidentiel et ne doit pas être reproduit ou utilisé sans le consentement de EXM



TOP

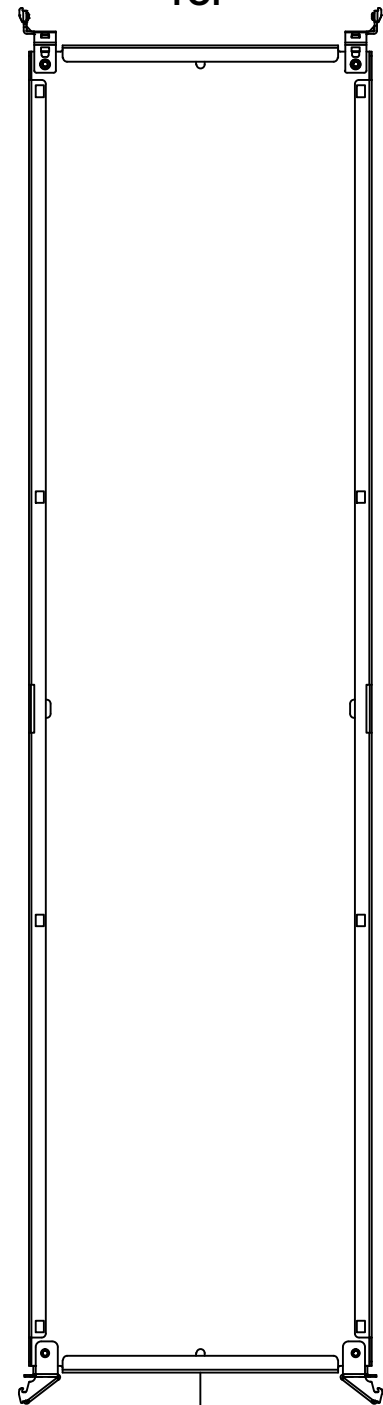

BACK



BOTTOM

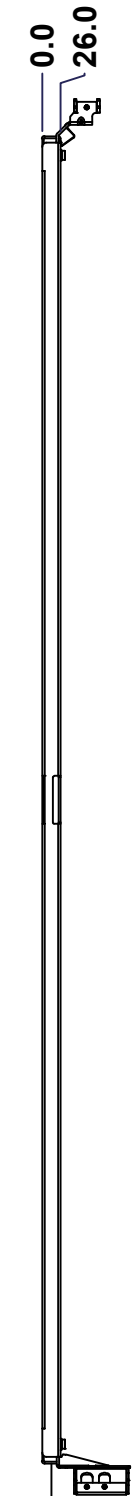

LEFT

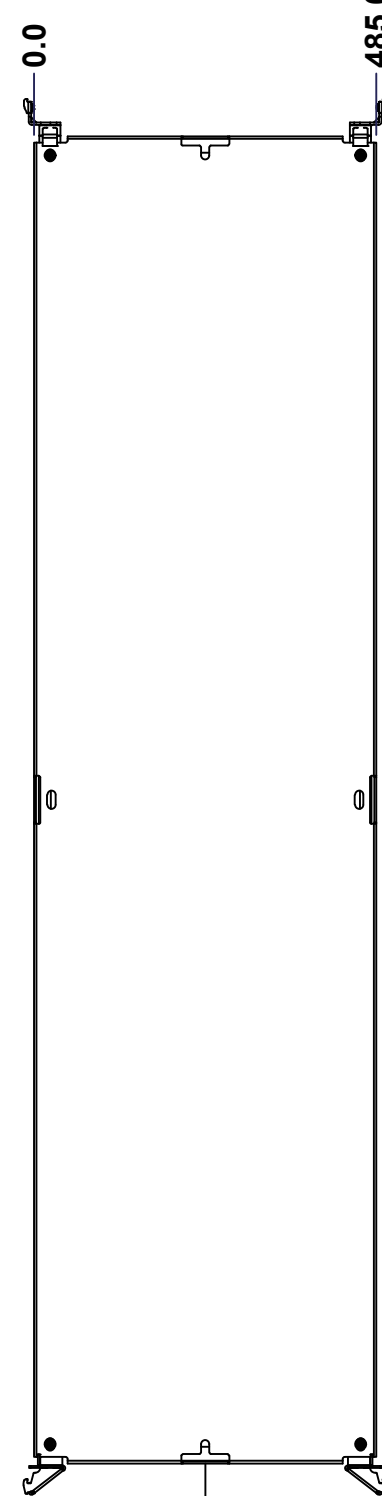

FRONT

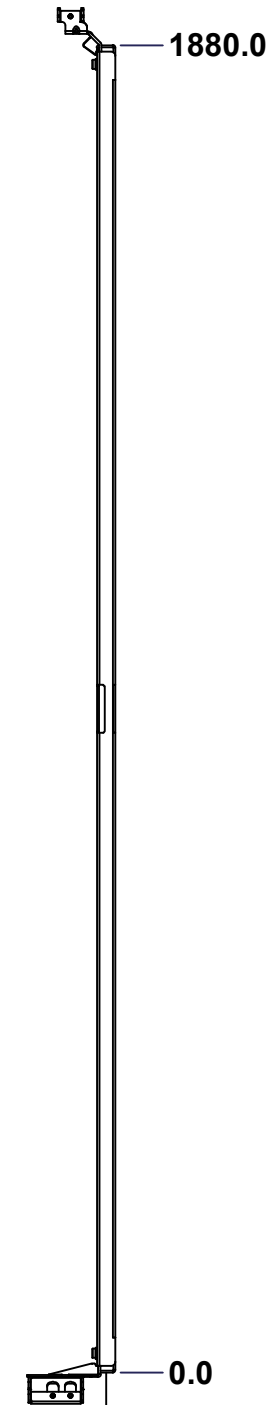

RIGHT

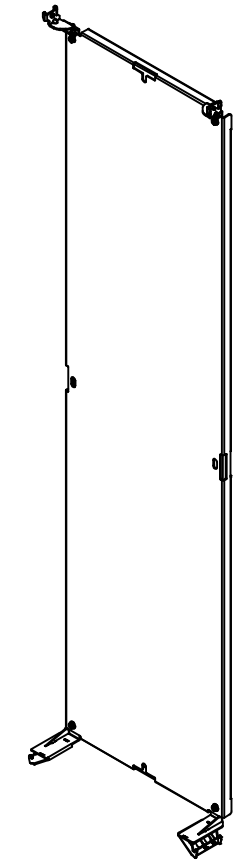

Isometric View

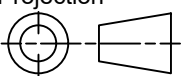

No.	Revisions	Date	By/Par

 Tél: (450) 979-4373 Fax: (450) 979-4626 www.exmweb.com		Flatness Aplatissement Max 3.0mm Projection 
Customer Client	Date	
Drawn By Dessiné Par	BoxCad: BoxCad	Date 09-Mar-15
Material Matière	12 Ga Galvanized (2.5mm)	
Color Couleur	Unpainted	Finish Fini Unpainted
Description	Detail Rev.	
6500 MXM 2000mm x 600mm Back Inner Panel		
Part Number Numéro Pièce	Rev.	17
6500MXU200604BIP	0	18

SEE BILL OF MATERIAL ON LAST PAGE

This drawing is confidential and must not be reproduced or used without the consent of EXM

Ce dessin est confidentiel et ne doit pas être reproduit ou utilisé sans le consentement de EXM

No.	Revisions	Date	By/Par

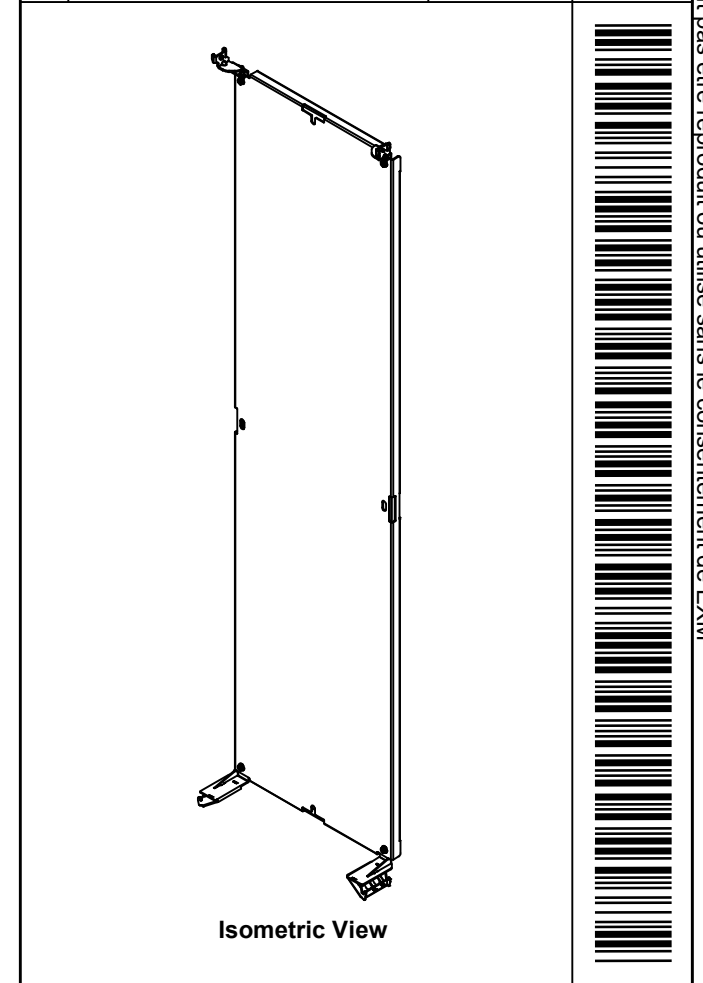

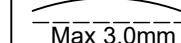
 Tél: (450) 979-4373 Fax: (450) 979-4626 www.exmweb.com		Flatness Aplatissement  Max 3.0mm
Customer Client		Date
Drawn By / Dessiné Par: BoxCad: BoxCad		Date: 09-Mar-15
Material / Matière: 12 Ga Galvanized (2.5mm)		
Color / Couleur: Unpainted	Finish / Fini: Unpainted	
Description: 6500 MXM 2000mm x 600mm Back Inner Panel		Detail Rev.
Part Number / Numéro Pièce: 6500MXU200604BIP		Rev. 0 / 18

Qty	Part Number	Rev	Description
1	STK-A-49005	5	6500 MXM - Bottom Inner Panel Support Assembly (Right)
1	STK-A-49000	5	6500 MXM - Bottom Inner Panel Support Assembly (Left)
1	STK-A-49015	0	6500MXM - Top Inner Panel Support Kit (Right)
1	STK-A-49010	0	6500MXM - Top Inner Panel Support Kit (Left)
1	6500MXU200604BIP-P	0	6500 MXM 2000mm x 600mm Back Inner Panel Part
Parts List			