

This drawing is confidential and must not be reproduced or used without the consent of EXM

Ce dessin est confidentiel et ne doit pas être reproduit ou utilisé sans le consentement de EXM

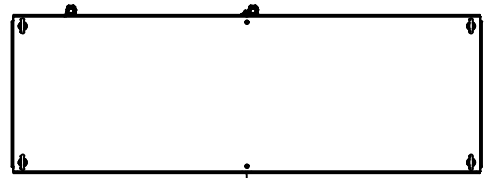

TOP

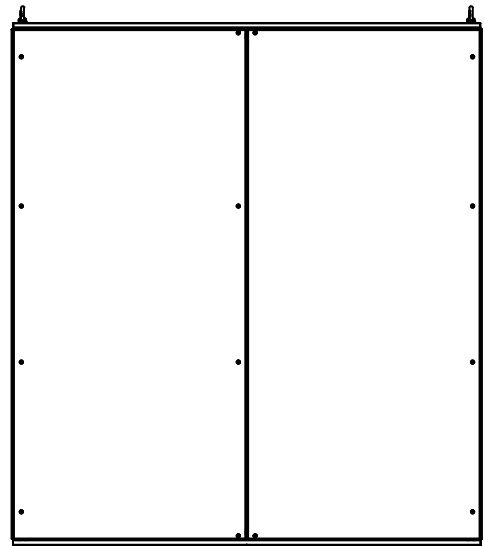

BACK

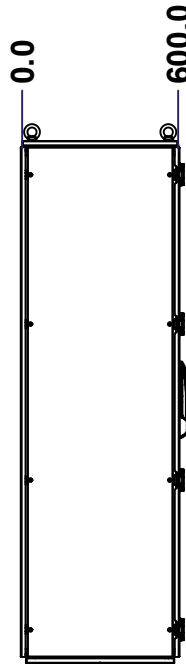

LEFT

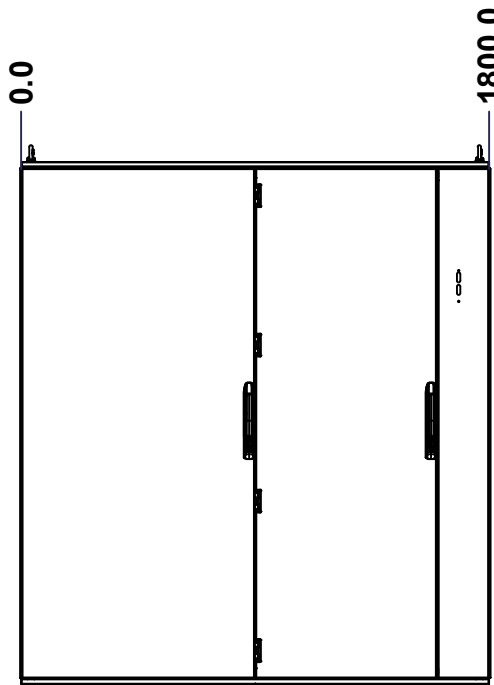

FRONT

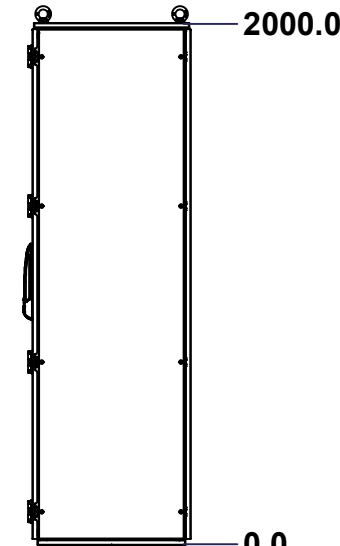

RIGHT

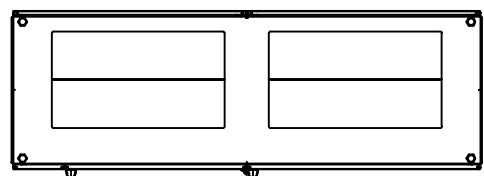

BOTTOM

No.	Revisions	Date	By/Par

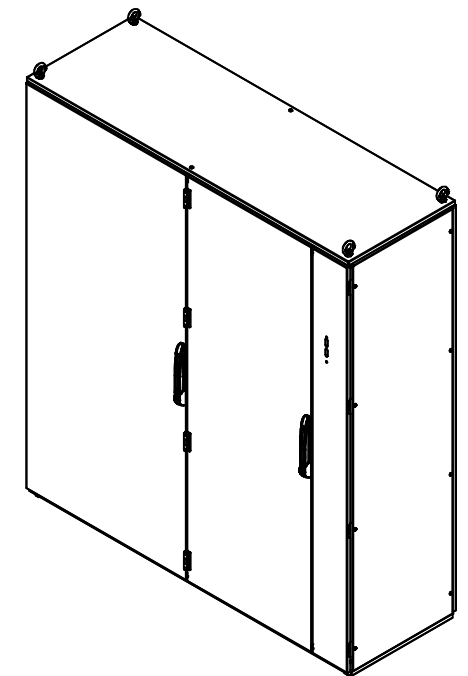

Isometric View

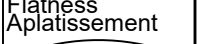
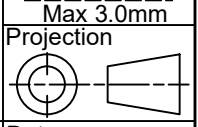

 Tél: (450) 979-4373 Fax: (450) 979-4626 <a href="http://www.exmweb.com">www.exmweb.com</a>		Flatness Aplatissement  Max 3.0mm Projection 
Customer Client	Date	
Drawn By Dessiné Par	BoxCad: BoxCad	Date 10-Mar-15
Material Matière	See Part List	
Color Couleur	See Part List	Finish Fini See Part List
Description 6500MX 2000mm x 1800mm x 600mm Assembly		Detail Rev.
Part Number Numéro Pièce	Rev. 0	1 / 24

SEE BILL OF MATERIAL ON LAST PAGE

**6500MXUDD201806**

This drawing is confidential and must not be reproduced or used without the consent of EXM

Ce dessin est confidentiel et ne doit pas être reproduit ou utilisé sans le consentement de EXM

No.	Revisions	Date	By/Par

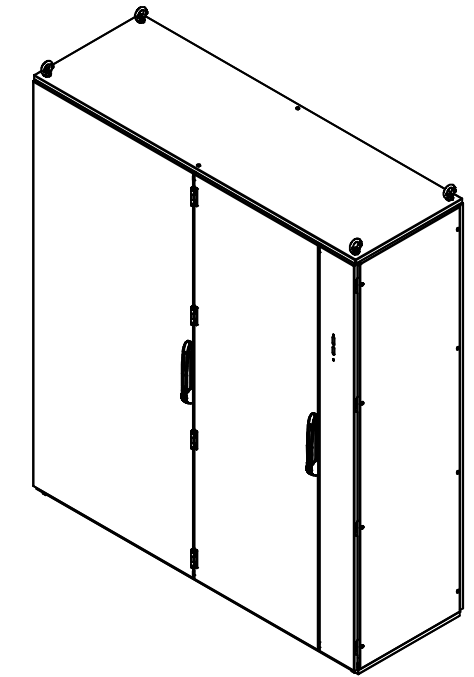

Isometric View



Tél: (450) 979-4373  
 Fax: (450) 979-4626  
[www.exmweb.com](http://www.exmweb.com)

Flatness  
Aplatissement  
Max 3.0mm  
Projection

Customer Client	Date
Drawn By Dessiné Par BoxCad: BoxCad	Date 10-Mar-15

Material Matière See Part List

Color Couleur	See Part List	Finish Fini	See Part List
---------------	---------------	-------------	---------------

Description 6500MX 2000mm x 1800mm x 600mm Assembly  
 Detail Rev.

Part Number Numéro Pièce	Rev.	2
<b>6500MXUDD201806</b>	<b>0</b>	24

Qty	Part Number	Rev	Description
1	6500MXUDD201806BIP	0	6500 MXM 2000mm x 1800mm Back Inner Panel
1	6500MXUDD201806R	0	6500 MXC 2000mm x 600mm Right
1	6500MXUDD201806L	0	6500 MXC 2000mm x 600mm Left
1	6500MXUDD201806F	0	6500 MXDDU 2000mm x 1800mm Front
1	6500MXUDD201806B	0	6500 MXR 2000mm x 1800mm Back
1	6500MXUDD201806BT	0	6500 MXB 1800mm x 600mm Bottom
1	6500MXUDD201806T	0	6500 MXT 1800mm x 600mm Top
1	6500MXUDD201806FR	0	6500 MX 2000mm x 1800mm x 600mm Frame
Parts List			

This drawing is confidential and must not be reproduced or used without the consent of EXM

Ce dessin est confidentiel et ne doit pas être reproduit ou utilisé sans le consentement de EXM

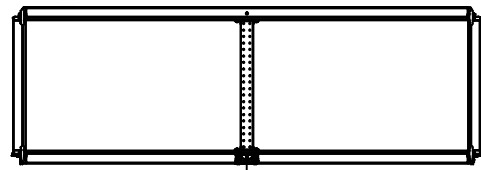

TOP

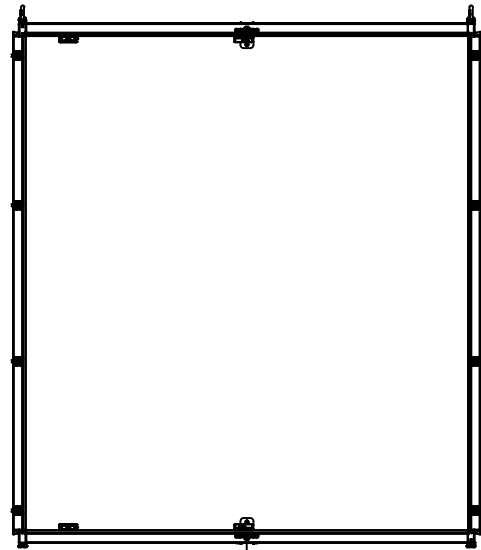

BACK

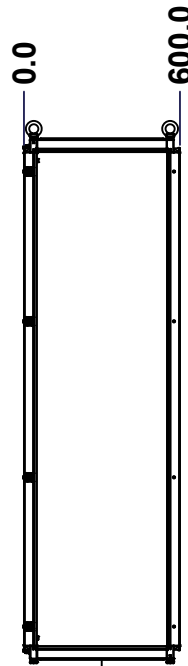

LEFT

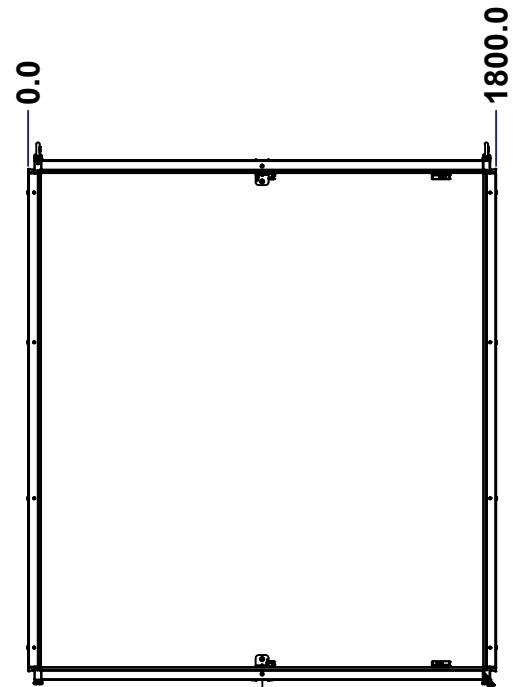

FRONT

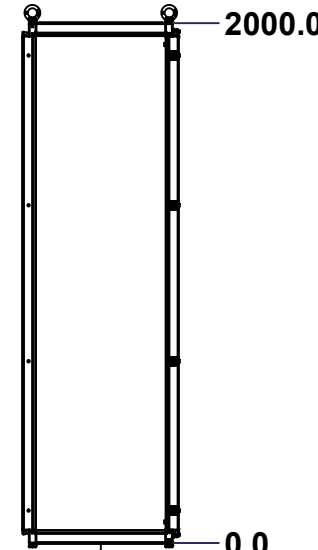

RIGHT

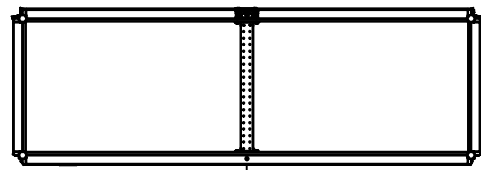

BOTTOM

Grind excess weld off corner(s)

No.	Revisions	Date	By/Par

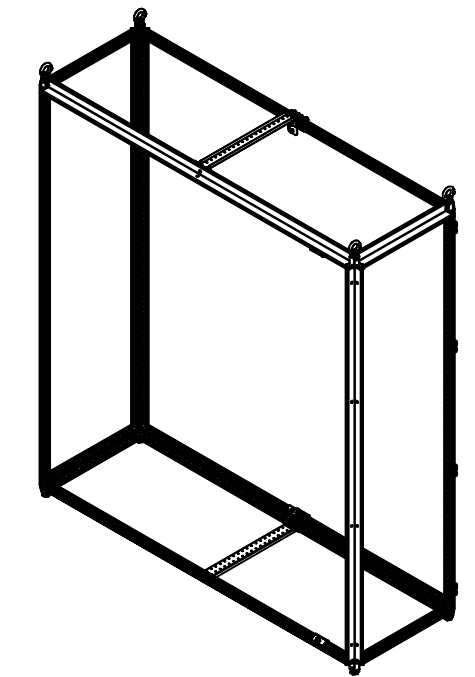

Isometric View



Tél: (450) 979-4373  
 Fax: (450) 979-4626  
[www.exmweb.com](http://www.exmweb.com)

Flatness  
Aplatissement  
Max 3.0mm  
Projection

Customer Client	Date
Drawn By / Dessiné Par: BoxCad: BoxCad	Date: 10-Mar-15
Material / Matière: 16 Ga Electro-Galvanized (1.4mm)	
Color / Couleur: Iron Grey RAL7011	Finish / Fini: Textured
Description: 6500 MX 2000mm x 1800mm x 600mm Frame	Detail Rev.
Part Number / Numéro Pièce: 6500MXUDD201806FR	Rev. 3

SEE BILL OF MATERIAL ON LAST PAGE

This drawing is confidential and must not be reproduced or used without the consent of EXM

Ce dessin est confidentiel et ne doit pas être reproduit ou utilisé sans le consentement de EXM

No.	Revisions	Date	By/Par

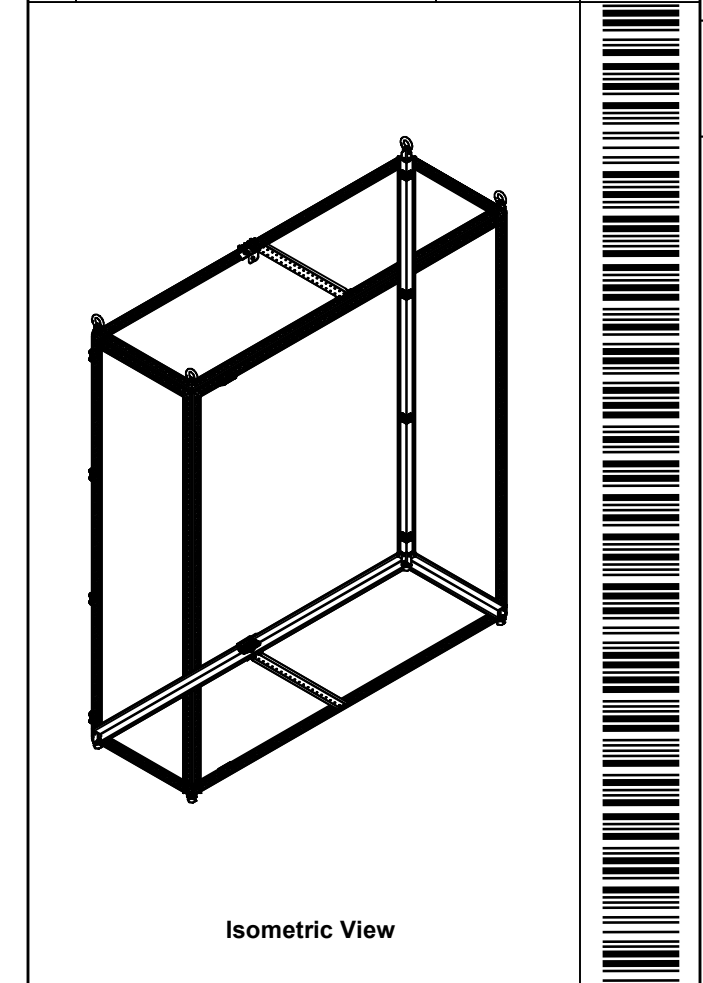

Isometric View

1	STK-P-03810ST	0	Powder Paint (Iron Grey /Sand Textured)
2	STK-A-11016	9	Rear Panel Double Bracket
1	STK-Q-04000	4	M6.0 x 9.5mm Truss Head Tapping Screw
4	STK-Q-47250-18	6	6500 MX 1800mm Horizontal Frame Post Part
4	STK-Q-47250-06	6	6500 MX 600mm Horizontal Frame Post Part
4	STK-Q-05020	5	M5 x 8mm Thread Rolling Screw
4	STK-A-74730	2	6500 MX - Flange Door Sealing Block
5	STK-Q-77120	1	6500MX-Frame Rubber Plug
8	STK-A-70580	9	Mtrx Bracket
8	STK-Q-00610	3	M16 x 30.0mm Bolt
8	STK-A-49448	6	6500 MX - Frame Sheet Metal Corner Assembly
4	STK-Q-49500	3	M12 Eye Bolt (0.34T)
4	STK-Q-61110	0	M12 Feet Leveler
4	STK-Q-47251-20	6	6500 MX 2000mm Vertical Frame Post Part
2	STK-K-49040-06	0	Reinforcement Bracket Kit with 600mm Track
Qty	Part Number	Rev	Description

Parts List

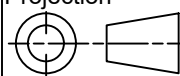
 Tél: (450) 979-4373 Fax: (450) 979-4626 <a href="http://www.exmweb.com">www.exmweb.com</a>	Flatness Aplatissement
	Max 3.0mm
Projection	
Customer Client	Date
Drawn By Dessiné Par BoxCad: BoxCad	Date 10-Mar-15
Material Matière	16 Ga Electro-Galvanized (1.4mm)
Color Couleur Iron Grey RAL7011	Finish Fini Textured
Description 6500 MX 2000mm x 1800mm x 600mm Frame	Detail Rev.
Part Number Numéro Pièce <b>6500MXUDD201806FR</b>	Rev. 4 <b>0</b>

This drawing is confidential and must not be reproduced or used without the consent of EXM

Ce dessin est confidentiel et ne doit pas être reproduit ou utilisé sans le consentement de EXM

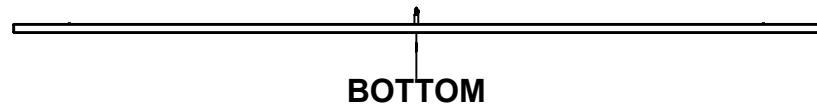
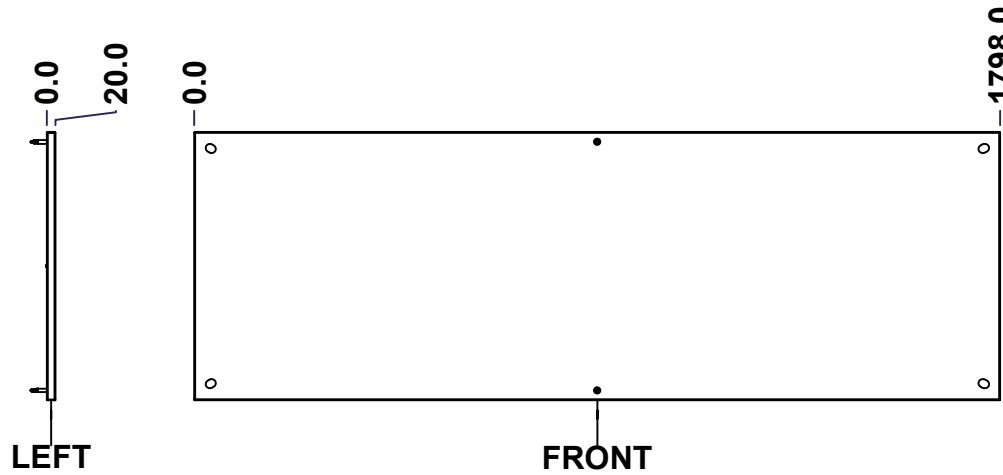
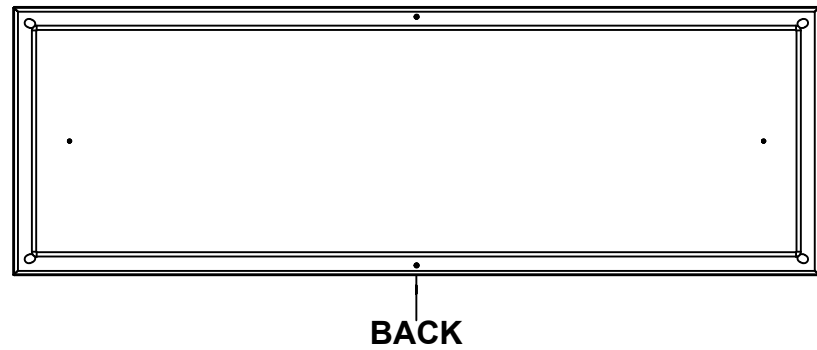
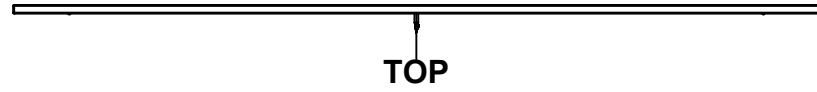

No.	Revisions	Date	By/Par

**Isometric View**

Tél: (450) 979-4373 Fax: (450) 979-4626 <a href="http://www.exmweb.com">www.exmweb.com</a>		Flatness Aplatissement
		Max 3.0mm
Customer Client		Date
Drawn By / Dessiné Par: BoxCad: BoxCad		Date: 10-Mar-15
Material / Matière: 16 Ga Cold Rolled A1008 CS Type B		
Color / Couleur: Iron Grey RAL7011	Finish / Fini: Textured	
Description: 6500 MXT 1800mm x 600mm Top		Detail Rev.
Part Number / Numéro Pièce: <b>6500MXUDD201806T</b>		Rev. 5 <b>0</b> / 24

Use gasket program path 6500 MX > 6500 MXT

SEE BILL OF MATERIAL ON LAST PAGE

This drawing is confidential and must not be reproduced or used without the consent of EXM

Ce dessin est confidentiel et ne doit pas être reproduit ou utilisé sans le consentement de EXM

STANDARD FEATURES ARE NOT LISTED IN THIS HOLE TABLE			
HOLE TABLE - FRONT VIEW (CUSTOM FEATURE ONLY)			
CUT-OUT	XDIM	YDIM	DESCRIPTION
1	125.0	299.0	GND STUD M6 x 18mm (Inside)
2	1673.0	299.0	GND STUD M6 x 18mm (Inside)

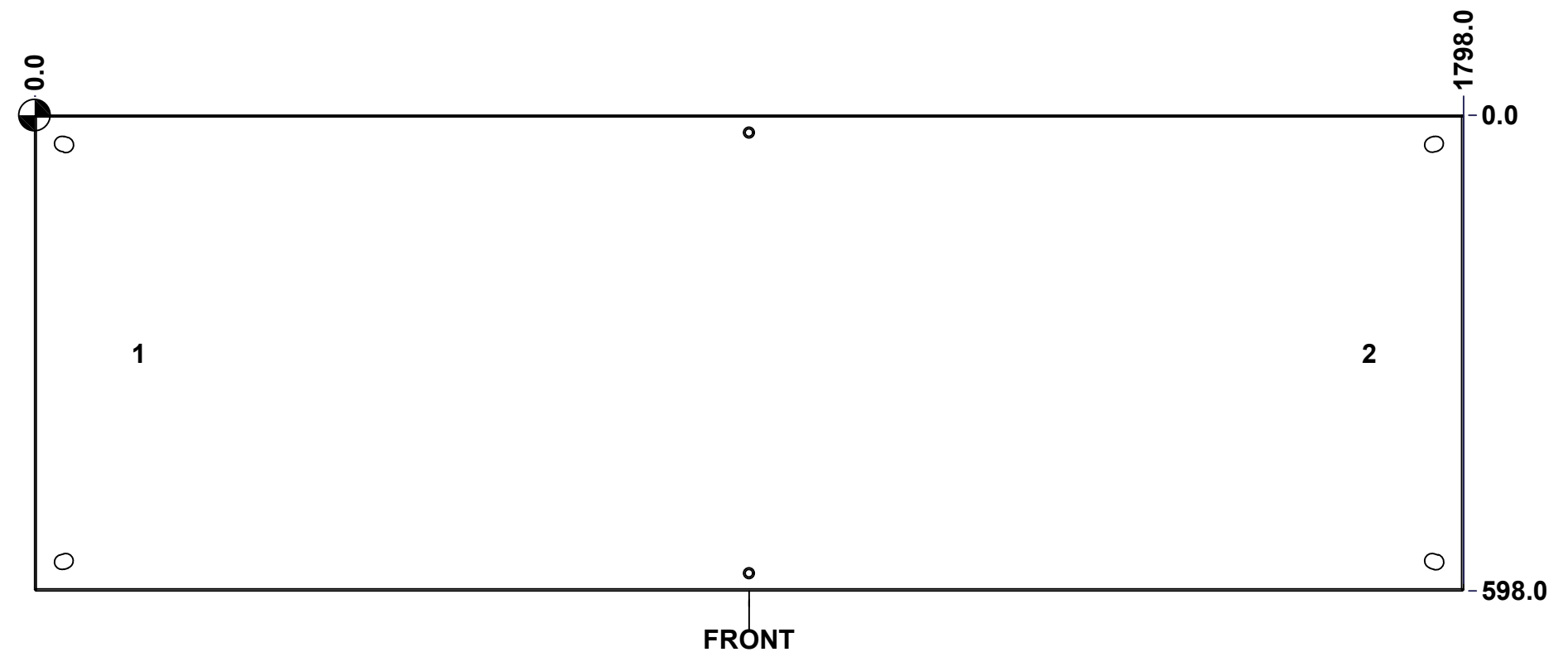

Use bending program path 6500 MX > 6500 MXT

	Description		Status
	6500 MXT 1800mm x 600mm Top		(NULL)
Part Number Numéro Pièce		Rev.	6
6500MXUDD201806T		0	24

This drawing is confidential and must not be reproduced or used without the consent of EXM

Ce dessin est confidentiel et ne doit pas être reproduit ou utilisé sans le consentement de EXM

No.	Revisions	Date	By/Par

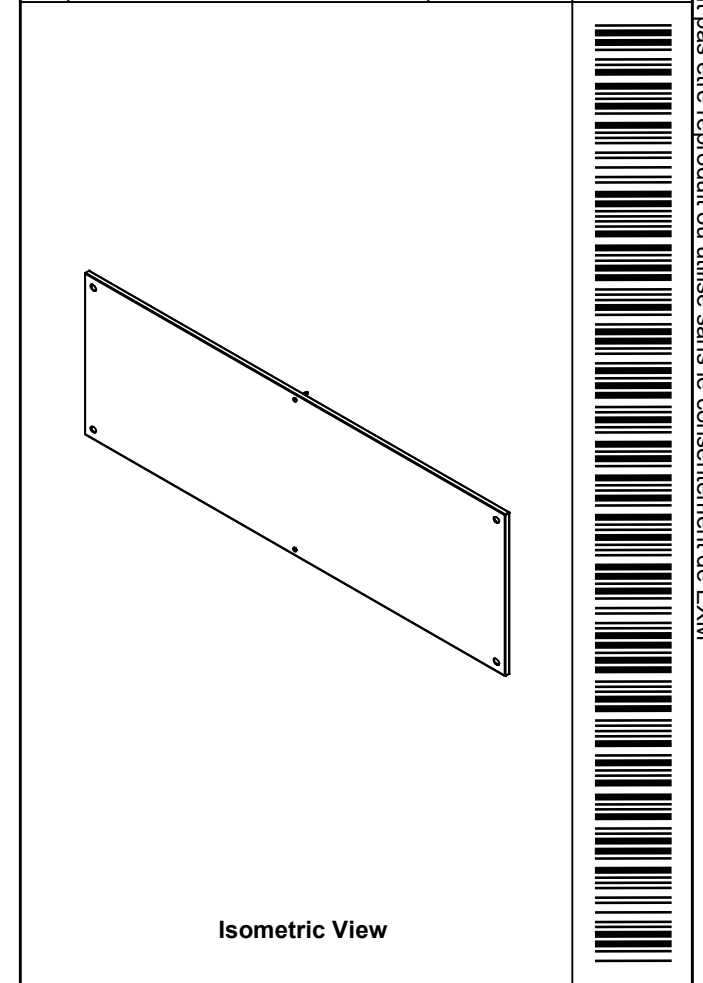

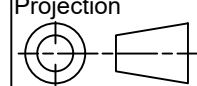
 Tél: (450) 979-4373 Fax: (450) 979-4626 <a href="http://www.exmweb.com">www.exmweb.com</a>		Flatness Aplatissement Max 3.0mm Projection 
Customer Client	Date	
Drawn By / Dessiné Par: BoxCad: BoxCad	Date: 10-Mar-15	
Material / Matière: 16 Ga Cold Rolled A1008 CS Type B		
Color / Couleur: Iron Grey RAL7011	Finish / Fini: Textured	
Description: 6500 MXT 1800mm x 600mm Top		Detail Rev.
Part Number / Numéro Pièce: <b>6500MXUDD201806T</b>		Rev. 7 / 24

Qty	Part Number	Rev	Description
1	STK-P-03810ST	0	Powder Paint (Iron Grey /Sand Textured)
2	STK-Q-16055	1	M6 x 18mm Stud (No Paint Cap Required)
2	STK-Q-90227	1	Flat Head Drilling Screw M6.3 x 56.0mm Long
1	6500MXUDD201806TG	0	6500 MXT 1800mm x 600mm Top Gasket
1	6500MXUDD201806T-P	0	6500 MXT 1800mm x 600mm Top Part
Parts List			

This drawing is confidential and must not be reproduced or used without the consent of EXM

Ce dessin est confidentiel et ne doit pas être reproduit ou utilisé sans le consentement de EXM

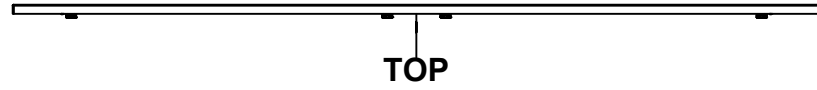

TOP

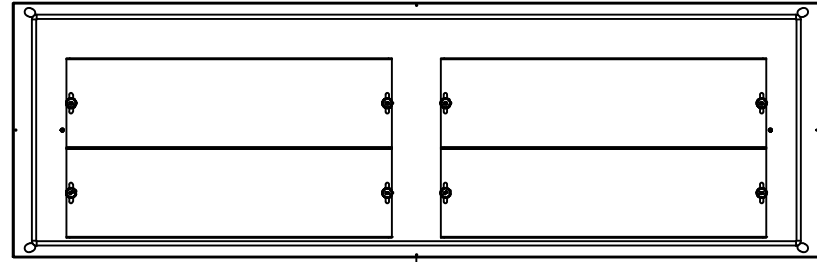

BACK

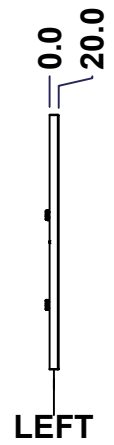

LEFT

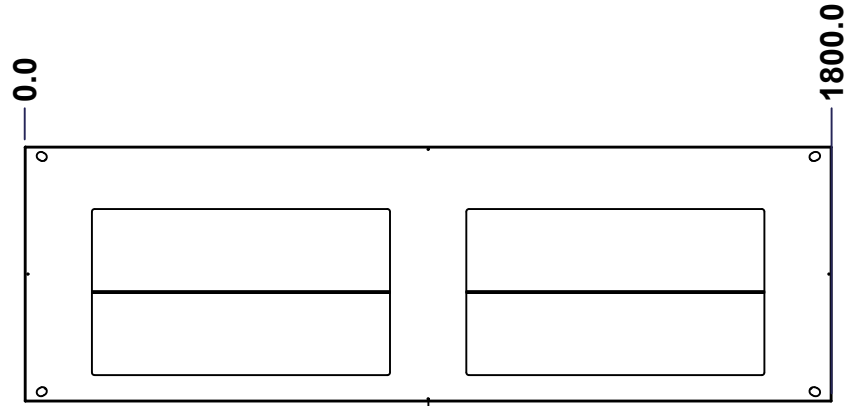

FRONT

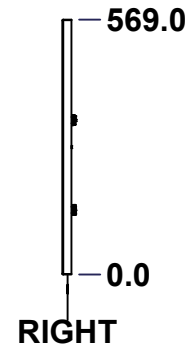

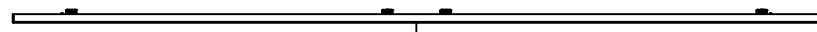

RIGHT

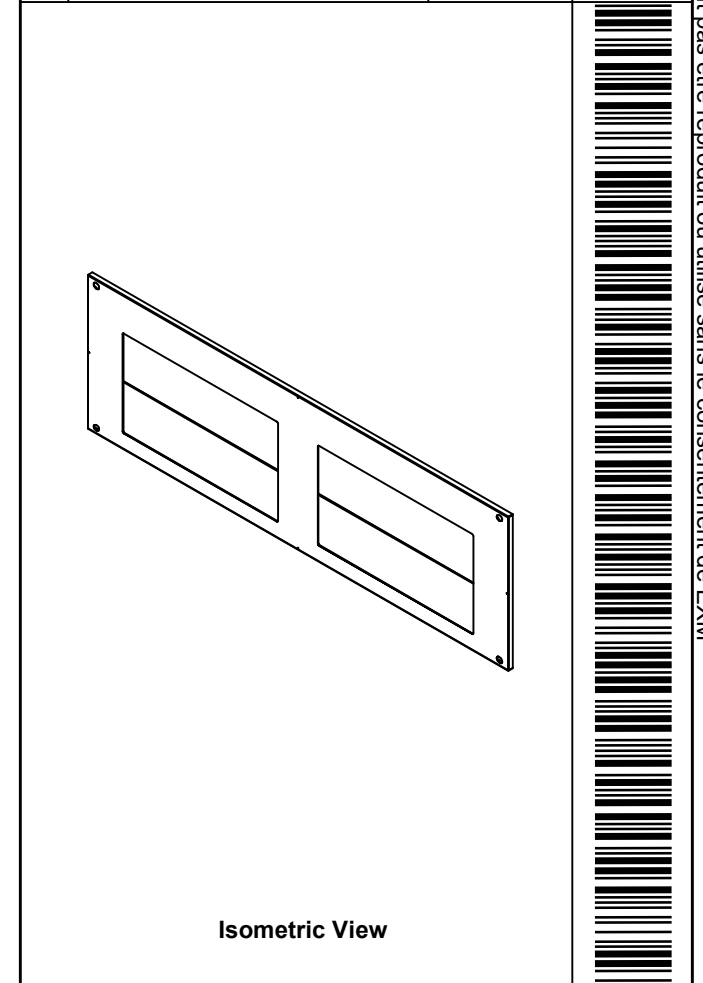

BOTTOM

No.	Revisions	Date	By/Par

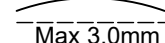

 Tél: (450) 979-4373 Fax: (450) 979-4626 <a href="http://www.exmweb.com">www.exmweb.com</a>		Flatness Aplatissement  Max 3.0mm
Customer Client		Date
Drawn By Dessiné Par BoxCad: BoxCad		Date 10-Mar-15
Material Matière 16 Ga Cold Rolled A1008 CS Type B		
Color Couleur Iron Grey RAL7011	Finish Fini Textured	
Description 6500 MXB 1800mm x 600mm Bottom		Detail Rev.
Part Number Numéro Pièce <b>6500MXUDD201806BT</b>		Rev. 8 <b>0</b>

Use gasket program path 6500 MX > 6500MXB

SEE BILL OF MATERIAL ON LAST PAGE

This drawing is confidential and must not be reproduced or used without the consent of EXM

Ce dessin est confidentiel et ne doit pas être reproduit ou utilisé sans le consentement de EXM

**STANDARD FEATURES ARE NOT LISTED IN THIS HOLE TABLE**

**HOLE TABLE - FRONT VIEW (CUSTOM FEATURE ONLY)**

CUT-OUT	XDIM	YDIM	DESCRIPTION
1	110.0	284.5	GND STUD M6 x 18mm (Inside)
2	1690.0	284.5	GND STUD M6 x 18mm (Inside)
3	130.0	344.5	GP STUD M6 x 18mm (Inside)
4	1670.0	344.5	GP STUD M6 x 18mm (Inside)
5	130.0	144.5	GP STUD M6 x 18mm (Inside)
6	1670.0	144.5	GP STUD M6 x 18mm (Inside)
7	835.0	344.5	GP STUD M6 x 18mm (Inside)
8	965.0	344.5	GP STUD M6 x 18mm (Inside)
9	835.0	144.5	GP STUD M6 x 18mm (Inside)
10	965.0	144.5	GP STUD M6 x 18mm (Inside)

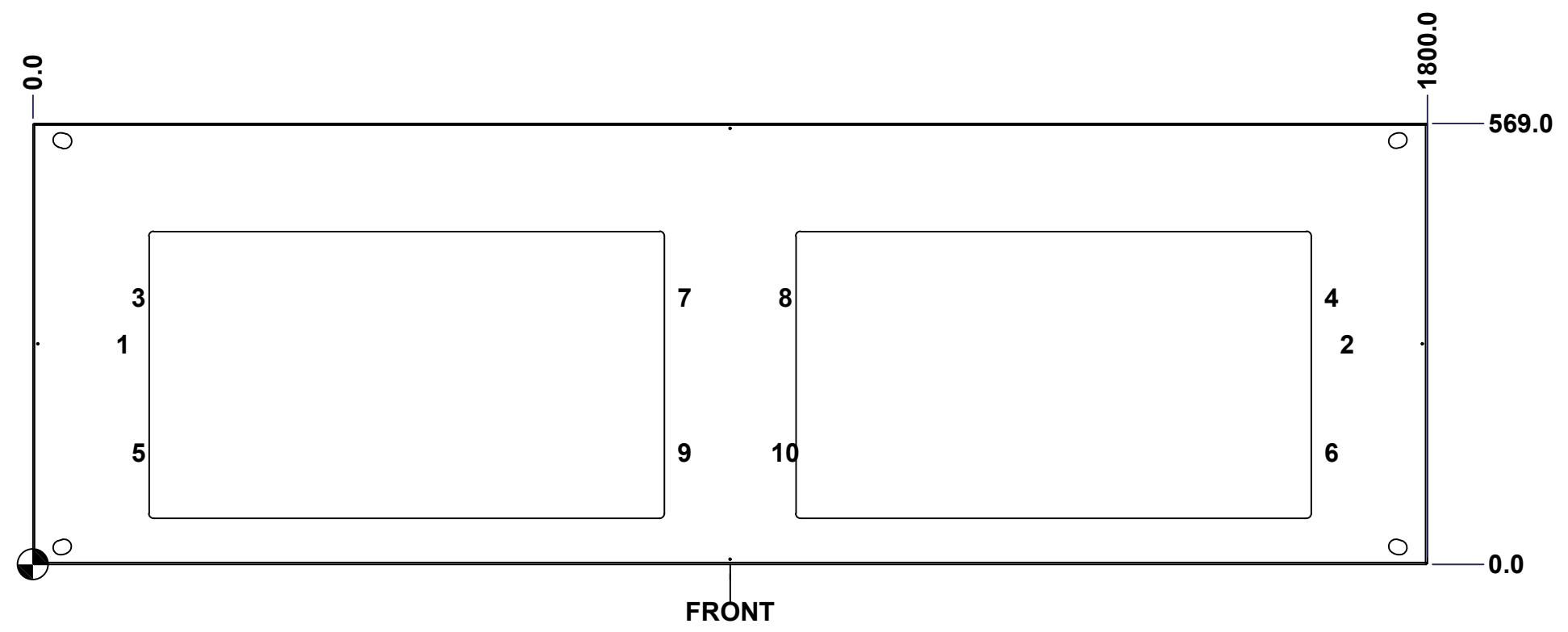

Use bending program path 6500 MX > 6500MXB

	Description	Status
	6500 MXB 1800mm x 600mm Bottom	(NULL)
Part Number Numéro Pièce <b>6500MXUDD201806BT</b>	Rev.	9
	<b>0</b>	24

This drawing is confidential and must not be reproduced or used without the consent of EXM

Ce dessin est confidentiel et ne doit pas être reproduit ou utilisé sans le consentement de EXM

No.	Revisions	Date	By/Par

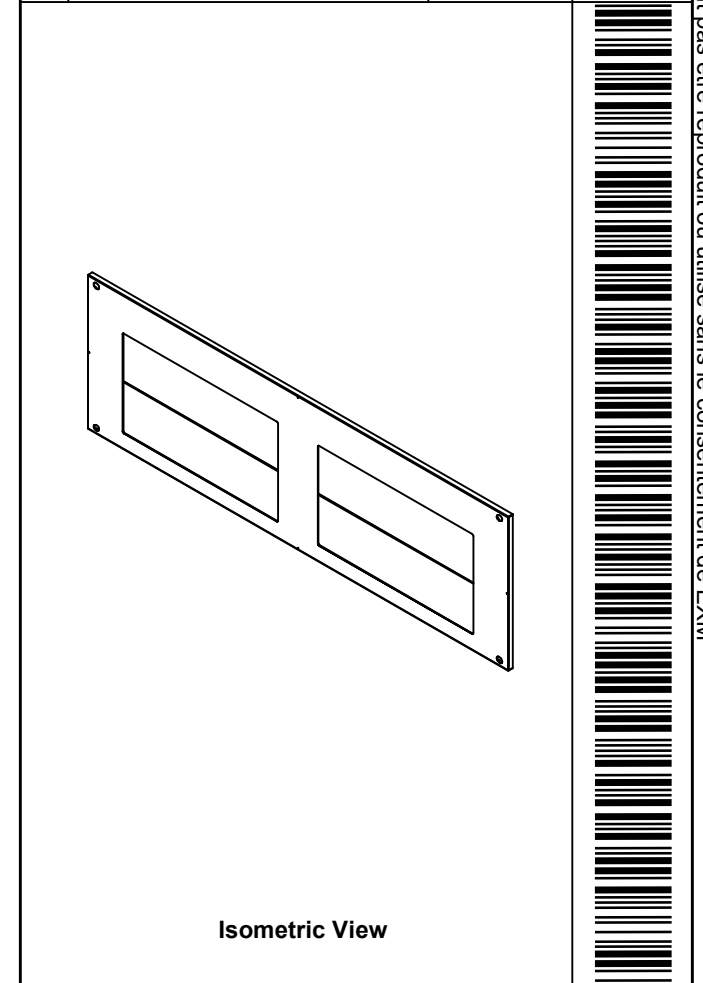

 Tél: (450) 979-4373 Fax: (450) 979-4626 <a href="http://www.exmweb.com">www.exmweb.com</a>	Flatness Aplatissement
	Max 3.0mm
Projection	

Customer Client	Date
Drawn By Dessiné Par	Date 10-Mar-15
Material Matière	16 Ga Cold Rolled A1008 CS Type B

Color Couleur	Iron Grey RAL7011	Finish Fini	Textured
Description	6500 MXB 1800mm x 600mm Bottom		
Detail Rev.			

Qty	Part Number	Rev	Description
1	STK-P-03810ST	0	Powder Paint (Iron Grey /Sand Textured)
8	STK-Q-06001	0	Mtrx - Gland Plate M6 Plastic Thumb Nut
10	STK-Q-16055	1	M6 x 18mm Stud (No Paint Cap Required)
4	6500MXUDD201806GP20 0-P	0	6500 MXB 1800mm Gland Plate Part (200mm)
2	6500MXUDD201806BTGP G	0	6500 MXB 1800mm x 600mm Bottom Gland Plate Gasket
1	6500MXUDD201806BTG	0	6500 MXB 1800mm x 600mm Bottom Gasket
1	6500MXUDD201806BT-P	0	6500 MXB 1800mm x 600mm Bottom Part
Parts List			

Part Number Numéro Pièce	Rev.	10
<b>6500MXUDD201806BT</b>	<b>0</b>	24

This drawing is confidential and must not be reproduced or used without the consent of EXM

Ce dessin est confidentiel et ne doit pas être reproduit ou utilisé sans le consentement de EXM



TOP

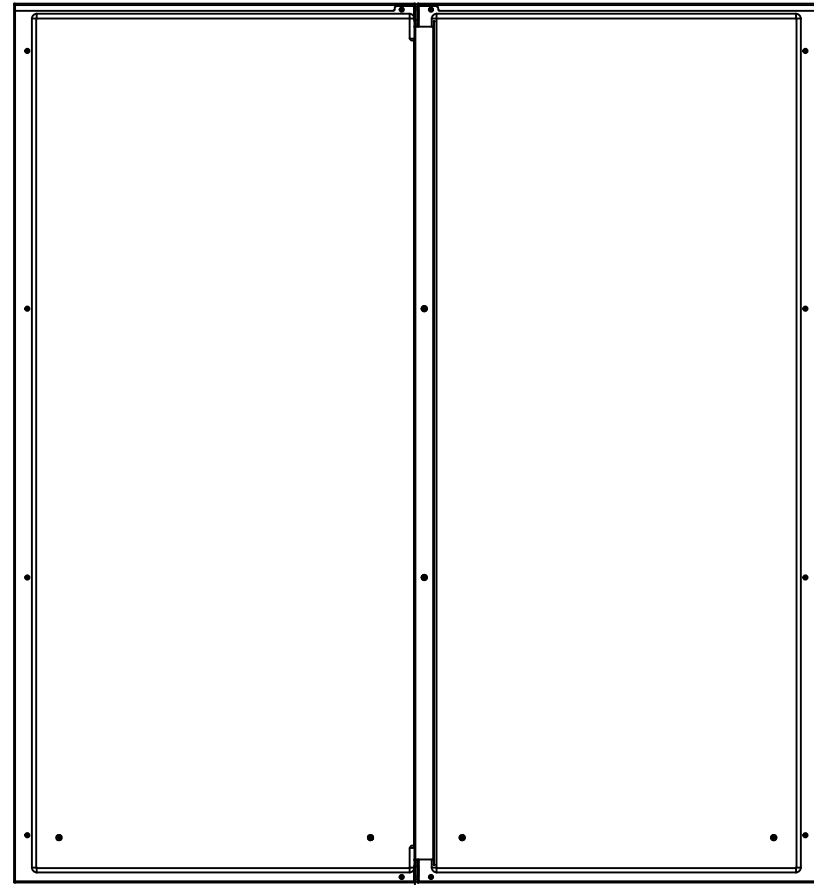

BACK



BOTTOM

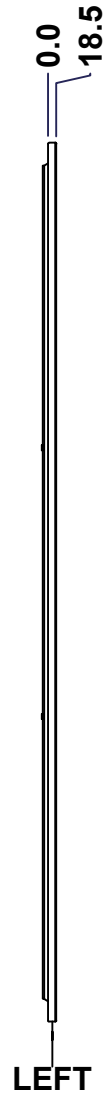

LEFT

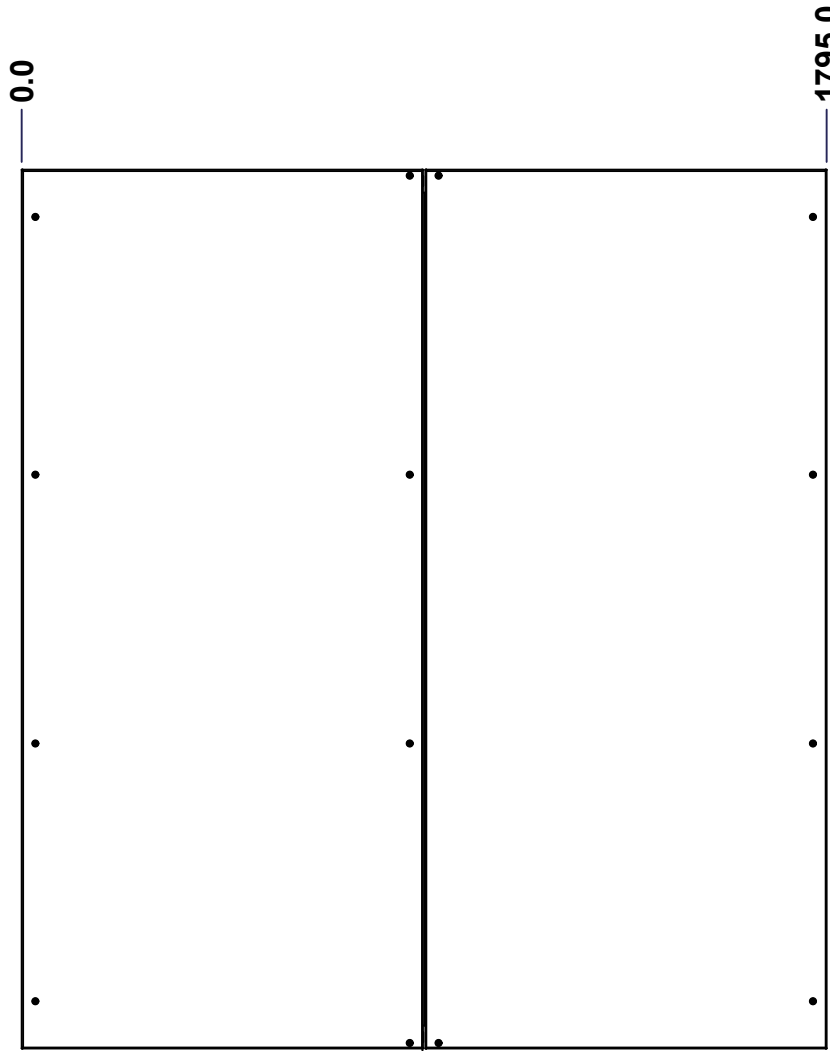

FRONT

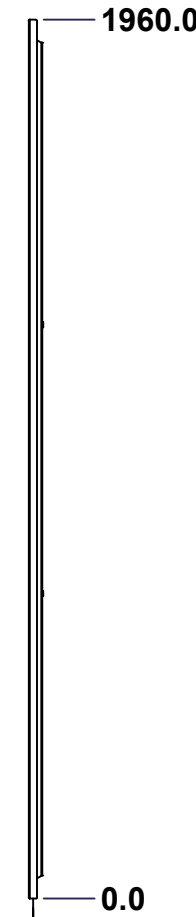

RIGHT

No.	Revisions	Date	By/Par

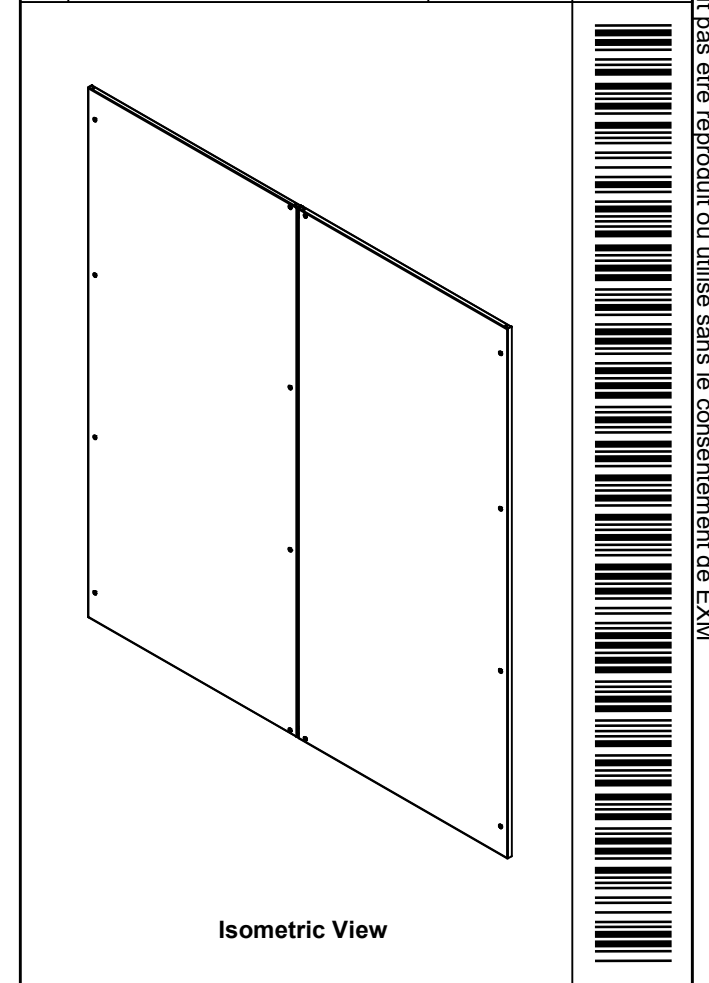

Isometric View

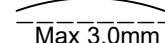
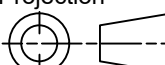

 Tél: (450) 979-4373 Fax: (450) 979-4626 <a href="http://www.exmweb.com">www.exmweb.com</a>		Flatness Aplatissement  Max 3.0mm Projection 
Customer Client	Date	
Drawn By Dessiné Par	BoxCad: BoxCad	Date 10-Mar-15
Material Matière	14 Ga Cold Rolled A1008 CS Type B	
Color Couleur	Light Grey RAL7035	Finish Fini Textured
Description	Detail Rev.	
6500 MXR 2000mm x 1800mm Back		
Part Number Numéro Pièce	Rev.	11
<b>6500MXUDD201806B</b>	<b>0</b>	24

Use gasket program path 6500 MX > 6500 MXR  
 Use gasket program path 6500 MX > 6500 MXRFD

SEE BILL OF MATERIAL ON LAST PAGE

This drawing is confidential and must not be reproduced or used without the consent of EXM

Ce dessin est confidentiel et ne doit pas être reproduit ou utilisé sans le consentement de EXM

**STANDARD FEATURES ARE NOT LISTED IN THIS HOLE TABLE**

**HOLE TABLE - FRONT VIEW (CUSTOM FEATURE ONLY)**

CUT-OUT	XDIM	YDIM	DESCRIPTION
1	100.0	100.0	GND STUD M6 x 16mm (Inside)
2	1695.0	100.0	GND STUD M6 x 16mm (Inside)
3	795.0	100.0	GND STUD M6 x 16mm (Inside)
4	1000.0	100.0	GND STUD M6 x 16mm (Inside)

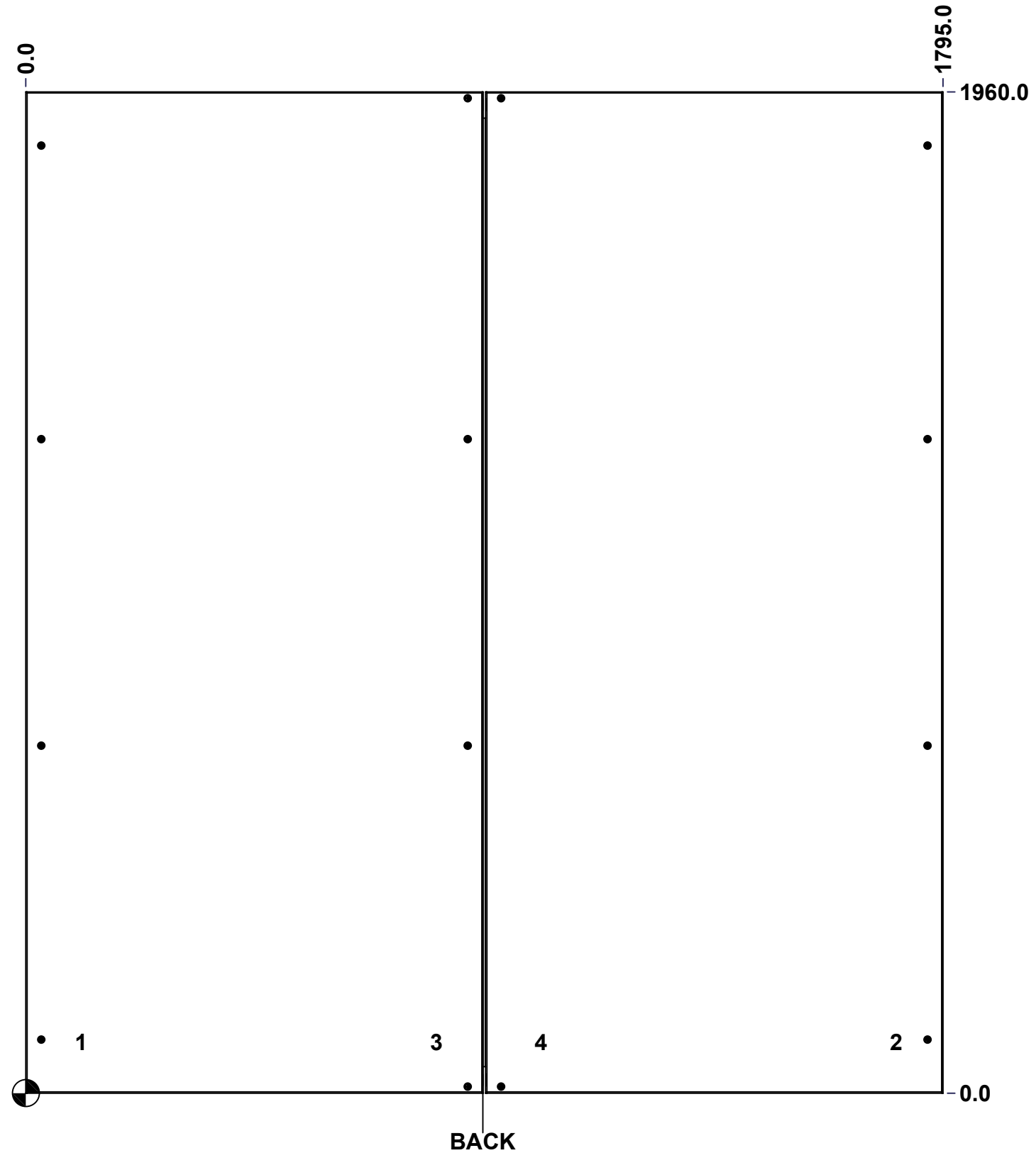

Use bending program path 6500 MX > 6500 MXR  
 Use bending program path 6500 MX > 6500 MXRFD

	Description	Status
	6500 MXR 2000mm x 1800mm Back	(NULL)
	Part Number Numéro Pièce	Rev.
	<b>6500MXUDD201806B</b>	<b>0</b>
		12
		24

This drawing is confidential and must not be reproduced or used without the consent of EXM

Ce dessin est confidentiel et ne doit pas être reproduit ou utilisé sans le consentement de EXM

No.	Revisions	Date	By/Par

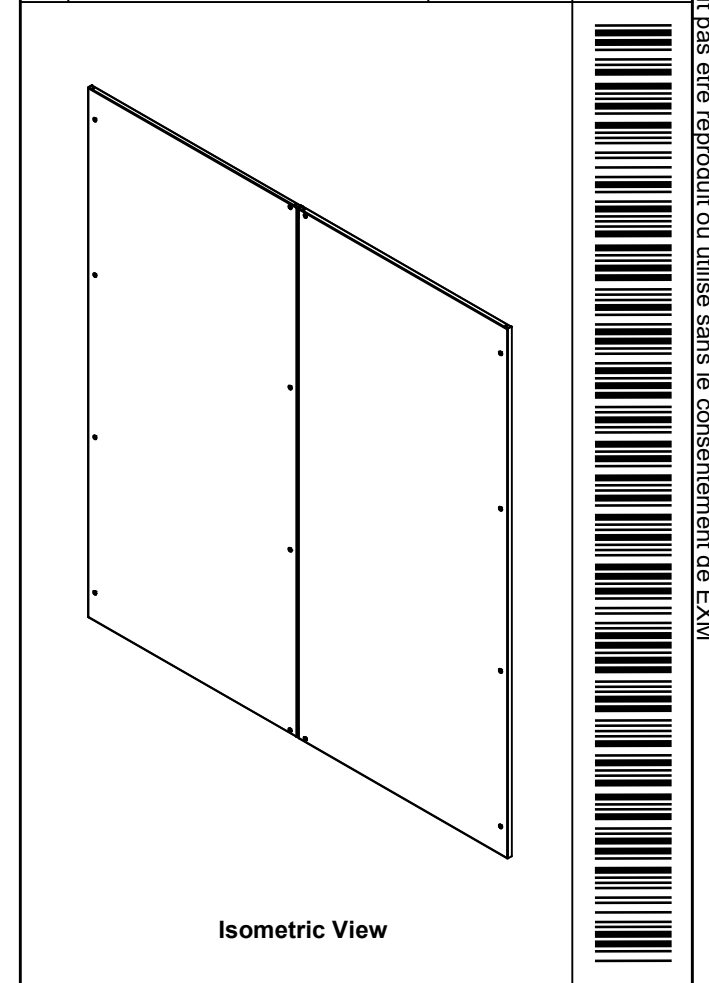

 Tél: (450) 979-4373 Fax: (450) 979-4626 <a href="http://www.exmweb.com">www.exmweb.com</a>	Flatness Aplatissement
	Max 3.0mm
Projection	

Customer Client	Date
Drawn By Dessiné Par	Date 10-Mar-15

Material Matière: 14 Ga Cold Rolled A1008 CS Type B

Color Couleur	Light Grey RAL7035	Finish Fini	Textured
---------------	--------------------	-------------	----------

Description	Detail Rev.
6500 MXR 2000mm x 1800mm Back	

Part Number Numéro Pièce	Rev.	13
<b>6500MXUDD201806B</b>	<b>0</b>	24

Qty	Part Number	Rev	Description
1	STK-P-03820R	0	Powder Paint (Light Grey / Rough Textured)
2	STK-Q-04050-08	0	M6 x 8mm Hexagon Socket Head Machine Screw
1	6500MXUDD201806B1G	0	6500 MXR 2000mm x 1800mm Back Gasket
1	6500MXUDD201806BG	0	6500 MXR 2000mm x 1800mm Back Gasket
2	STK-Q-11017	0	Rear Panel Single Bracket
14	STK-Q-03071	0	M6 x 16mm Machine Screw
1	6500MXUDD201806B1-P	0	6500 MXR 2000mm x 1800mm Back 1 Part
4	STK-Q-16080	0	Ground Stud M6 x 16mm Steel
1	6500MXUDD201806B-P	0	6500 MXR 2000mm x 1800mm Back Part
Parts List			

This drawing is confidential and must not be reproduced or used without the consent of EXM

Ce dessin est confidentiel et ne doit pas être reproduit ou utilisé sans le consentement de EXM

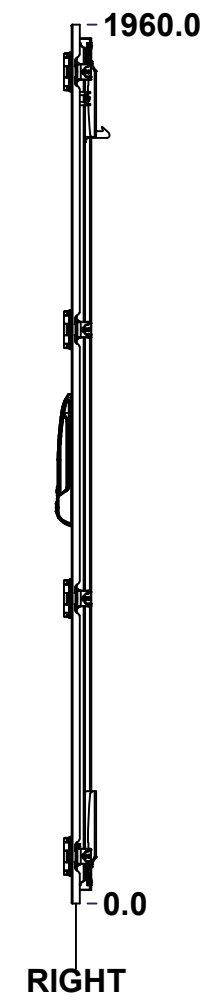
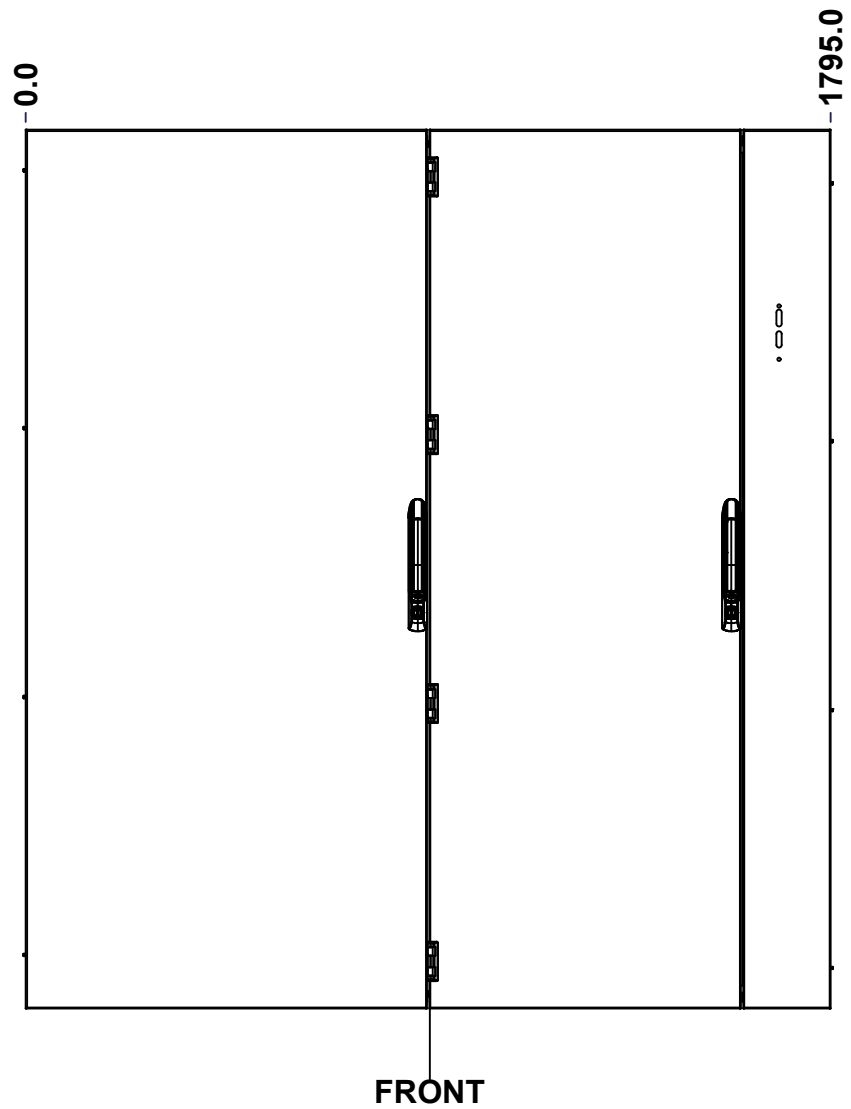
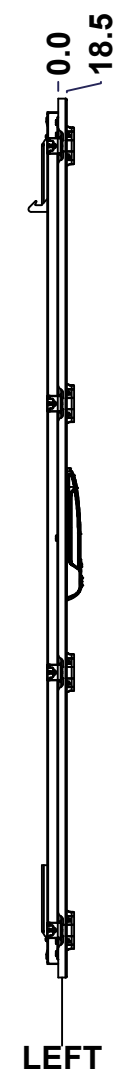
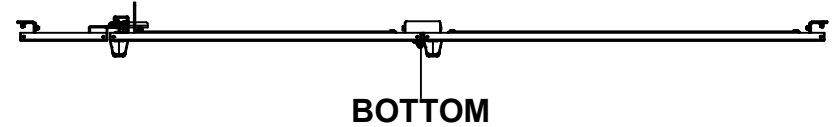
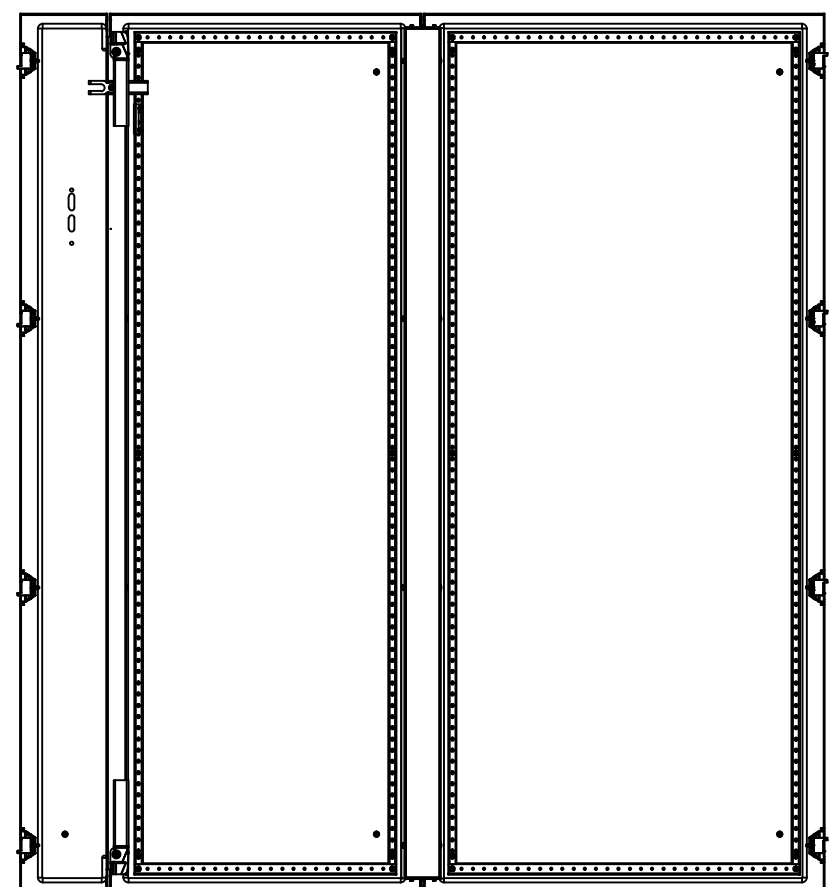
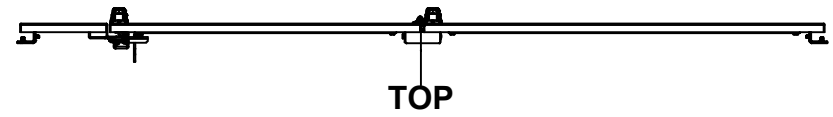

No.	Revisions	Date	By/Par

**Isometric View**

Tél: (450) 979-4373 Fax: (450) 979-4626 <a href="http://www.exmweb.com">www.exmweb.com</a>		Flatness Aplatissement
		Max 3.0mm
Customer Client		Date
Drawn By / Dessiné Par: BoxCad: BoxCad		Date: 10-Mar-15
Material / Matière: 14 Ga Cold Rolled A1008 CS Type B		
Color / Couleur: Light Grey RAL7035	Finish / Fini: Textured	
Description: 6500 MXDDU 2000mm x 1800mm Front		Detail Rev.
Part Number / Numéro Pièce: <b>6500MXUDD201806F</b>		Rev. 14 <b>0</b> / 24

**SEE BILL OF MATERIAL ON LAST PAGE**

This drawing is confidential and must not be reproduced or used without the consent of EXM

Ce dessin est confidentiel et ne doit pas être reproduit ou utilisé sans le consentement de EXM

STANDARD FEATURES ARE NOT LISTED IN THIS HOLE TABLE			
HOLE TABLE - FRONT VIEW (CUSTOM FEATURE ONLY)			
CUT-OUT	XDIM	YDIM	DESCRIPTION
1	1695.0	130.0	GND STUD M6 x 16mm (Inside)
2	100.0	130.0	GND STUD M6 x 16mm (Inside)
3	100.0	1830.0	GND STUD M6 x 16mm (Inside)
4	1000.0	130.0	GND STUD M6 x 16mm (Inside)
5	1000.0	1830.0	GND STUD M6 x 16mm (Inside)
6	1530.5	49.5	STIFF. STUD M6 x 18mm (Inside)
7	1530.5	980.0	STIFF. STUD M6 x 18mm (Inside)
8	1530.5	1910.5	STIFF. STUD M6 x 18mm (Inside)
9	64.5	49.5	STIFF. STUD M6 x 18mm (Inside)
10	64.5	980.0	STIFF. STUD M6 x 18mm (Inside)
11	64.5	1910.5	STIFF. STUD M6 x 18mm (Inside)
12	1530.5	81.0	STIFF. STUD M6 x 18mm (Inside)
13	1530.5	1879.0	STIFF. STUD M6 x 18mm (Inside)
14	964.5	81.0	STIFF. STUD M6 x 18mm (Inside)
15	964.5	1879.0	STIFF. STUD M6 x 18mm (Inside)
16	964.5	49.5	STIFF. STUD M6 x 18mm (Inside)
17	964.5	980.0	STIFF. STUD M6 x 18mm (Inside)
18	964.5	1910.5	STIFF. STUD M6 x 18mm (Inside)
19	830.5	49.5	STIFF. STUD M6 x 18mm (Inside)
20	830.5	980.0	STIFF. STUD M6 x 18mm (Inside)
21	830.5	1910.5	STIFF. STUD M6 x 18mm (Inside)
22	64.5	81.0	STIFF. STUD M6 x 18mm (Inside)
23	64.5	1879.0	STIFF. STUD M6 x 18mm (Inside)
24	830.5	81.0	STIFF. STUD M6 x 18mm (Inside)
25	830.5	1879.0	STIFF. STUD M6 x 18mm (Inside)
26	1574.0	170.0	LARGE CBAR GUIDE (Inside)
27	1574.0	1790.0	LARGE CBAR GUIDE (Inside)
28	1574.0	730.0	LARGE CBAR GUIDE (Inside)
29	1574.0	1230.0	LARGE CBAR GUIDE (Inside)
30	874.0	170.0	LARGE CBAR GUIDE (Inside)
31	874.0	1790.0	LARGE CBAR GUIDE (Inside)
32	874.0	730.0	LARGE CBAR GUIDE (Inside)
33	874.0	1230.0	LARGE CBAR GUIDE (Inside)

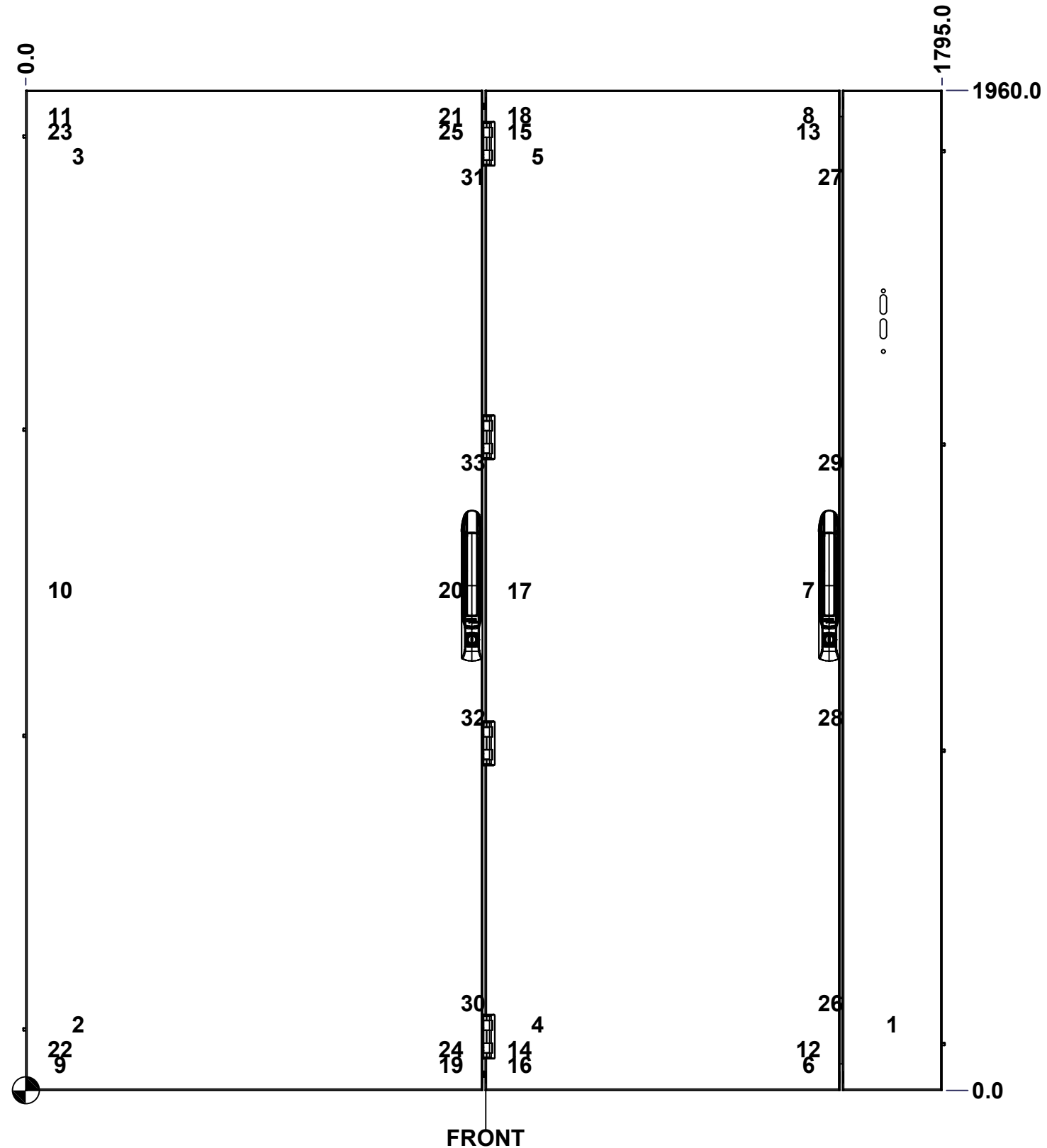

	Description	Status
	6500 MXDDU 2000mm x 1800mm Front	(NULL)
	Part Number	Rev.
	Numéro Pièce	15
	<b>6500MXUDD201806F</b>	<b>0</b>
		24

This drawing is confidential and must not be reproduced or used without the consent of EXM

Ce dessin est confidentiel et ne doit pas être reproduit ou utilisé sans le consentement de EXM

No.	Revisions	Date	By/Par

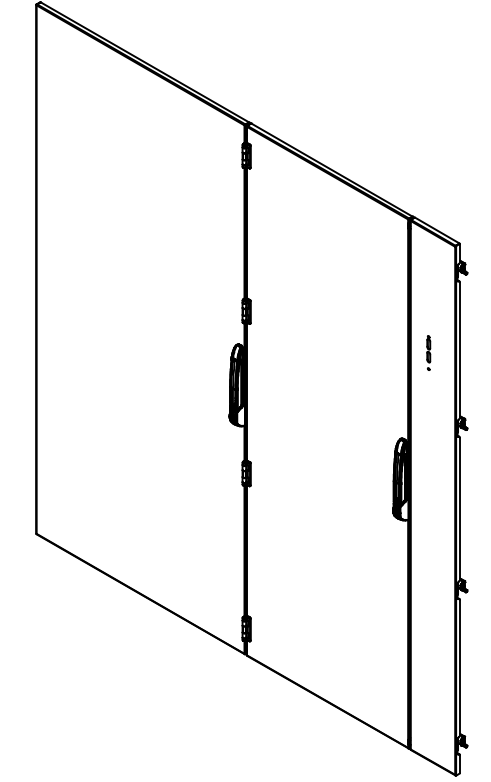

Isometric View



1	STK-P-03820R	0	Powder Paint (Light Grey / Rough Textured)
1	STK-Q-45758	1	886 PH2 Pull Handle Bridge Part
1	STK-A-51160	0	886PH2-SL - Pull Handle Lock - Assembly
1	6500MXUDD201806FCP	5	6500 MX 2000mm x 1800mm Center Part
1	6500MXUDD201806F1G	0	6500 MXDDU 2000mm x 1800mm Front Gasket
1	6500MXUDD201806DS1	5	6500 MX 2000mm x 1800mm Door Stiffener
1	6500MXUDD201806FG	0	6500 MXDDU 2000mm x 1800mm Front Gasket
4	STK-Q-16410	0	Guide Stud - Large (No Paint Cap Required)
4	STK-A-70586	3	Fixed Double Door Bracket Assembly
1	STK-Q-45662-20	1	6500 MX - Lower Closing Bar 2000mm
1	STK-Q-45661-20	1	6500 MX - Upper Closing Bar 2000mm
4	STK-K-06800-3	2	6500 MX 270° Hinge
1	6500MXUDD201806FD	0	6500 MXDDU 2000mm x 1800mm Front
1	STK-Q-46650	3	6500 MXDU Disconnect Hook
2	STK-Q-05020	5	M5 x 8mm Thread Rolling Screw
1	STK-Q-07220-P	0	M6 Nylon Insert Lock Nut
1	STK-Q-46750	4	6500 MXDU Disconnect Defeater
1	STK-K-10102	3	6500MX - Lock Handle Kit for Flange Door - Right
1	STK-K-10101	3	6500MX - Lock Handle Kit for Flange Door - Left
1	STK-Q-16030	0	Stud M6 x 10mm
2	STK-Q-16050	0	Stud M6 x 18mm
4	STK-K-06810	7	6500 MX Hinge Assy
1	6500MXUDD201806F1-P	0	6500 MXDDU 2000mm x 1800mm Front Part
10	STK-Q-16055	1	M6 x 18mm Stud (No Paint Cap Required)
3	STK-Q-16080	0.1.1	Ground Stud M6 x 16mm Steel
1	6500MXUDD201806F-P	0	6500 MXDDU 2000mm x 1800mm Front Part

Qty	Part Number	Rev.	Description
Parts List			

<p>Tél: (450) 979-4373 Fax: (450) 979-4626 <a href="http://www.exmweb.com">www.exmweb.com</a></p>	Flatness Aplatissement	Max 3.0mm
	Projection	
Customer Client	Date	
Drawn By Dessiné Par	BoxCad: BoxCad	Date 10-Mar-15
Material Matière	14 Ga Cold Rolled A1008 CS Type B	
Color Couleur	Light Grey RAL7035	Finish Fini Textured
Description	Detail Rev.	
6500 MXDDU 2000mm x 1800mm Front		
Part Number Numéro Pièce	Rev.	16
<b>6500MXUDD201806F</b>	<b>0</b>	24

This drawing is confidential and must not be reproduced or used without the consent of EXM

Ce dessin est confidentiel et ne doit pas être reproduit ou utilisé sans le consentement de EXM

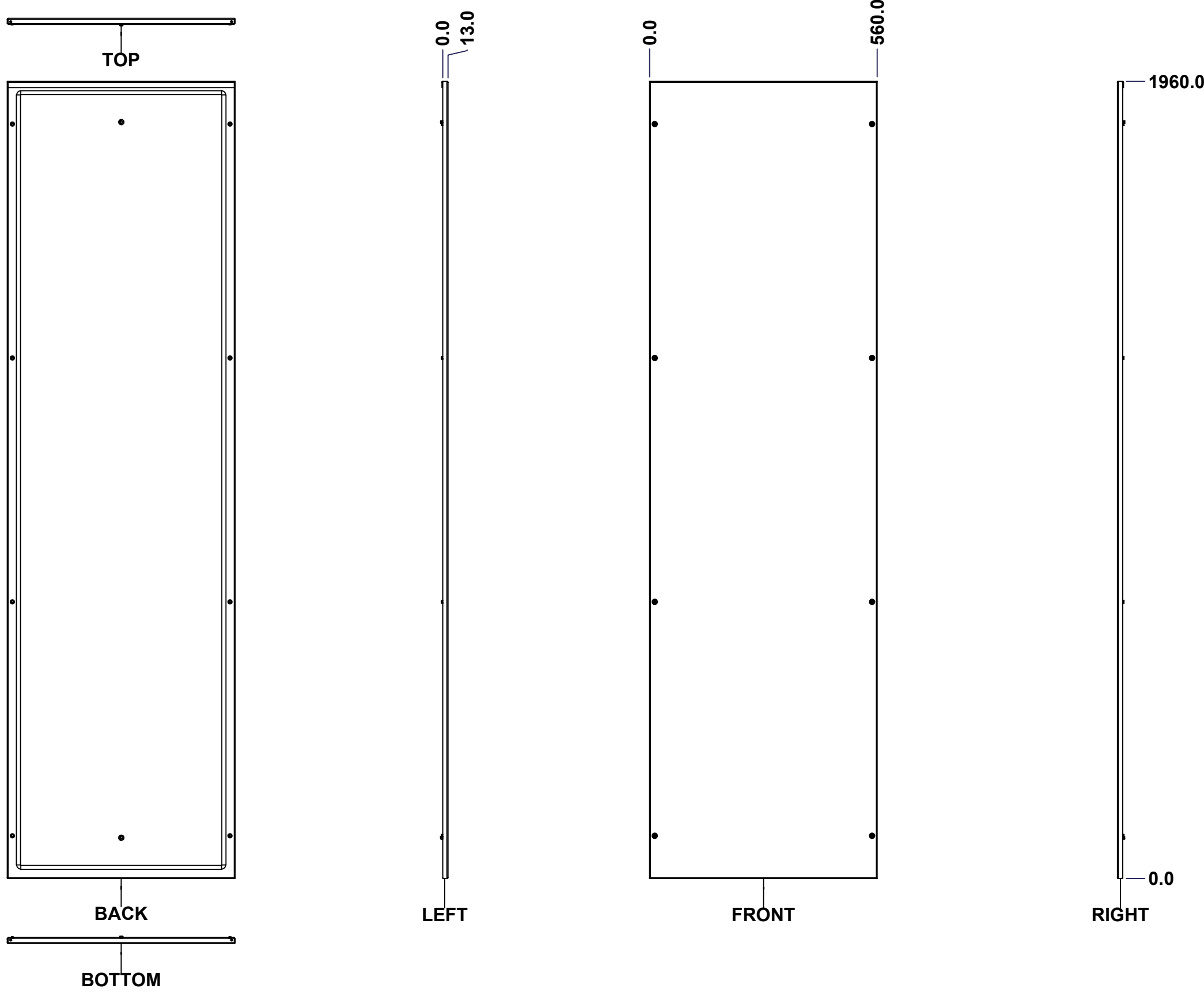

No.	Revisions	Date	By/Par

**Isometric View**

<p>Tél: (450) 979-4373 Fax: (450) 979-4626 <a href="http://www.exmweb.com">www.exmweb.com</a></p>		Flatness Aplatissement	
		Max 3.0mm	
Customer Client		Projection	
Date			
Drawn By Dessiné Par		Date	
BoxCad: BoxCad		10-Mar-15	
Material Matière			
16 Ga Cold Rolled A1008 CS Type B			
Color Couleur		Finish Fini	
Light Grey RAL7035		Textured	
Description			Detail Rev.
6500 MXC 2000mm x 600mm Left			
Part Number Numéro Pièce		Rev.	
6500MXUDD201806L		0	17 24

Use gasket program path 6500 MX > 6500 MXC

SEE BILL OF MATERIAL ON LAST PAGE

This drawing is confidential and must not be reproduced or used without the consent of EXM

Ce dessin est confidentiel et ne doit pas être reproduit ou utilisé sans le consentement de EXM

STANDARD FEATURES ARE NOT LISTED IN THIS HOLE TABLE			
HOLE TABLE - FRONT VIEW (CUSTOM FEATURE ONLY)			
CUT-OUT	XDIM	YDIM	DESCRIPTION
1	280.0	100.0	GND STUD M6 x 16mm (Inside)
2	280.0	1860.0	GND STUD M6 x 16mm (Inside)

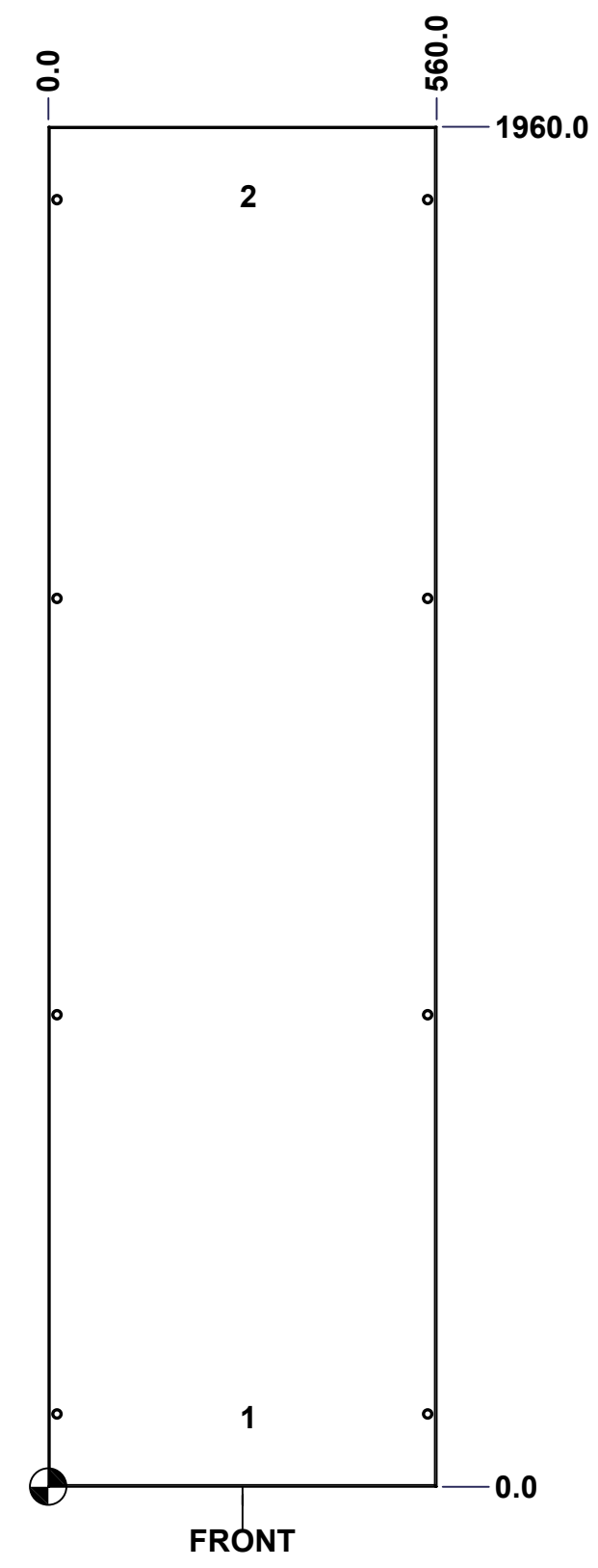

Use bending program path 6500 MX > 6500 MXC

	Description		Status
	6500 MXC 2000mm x 600mm Left		(NULL)
Part Number Numéro Pièce		Rev.	18
<b>6500MXUDD201806L</b>		<b>0</b>	24

This drawing is confidential and must not be reproduced or used without the consent of EXM

Ce dessin est confidentiel et ne doit pas être reproduit ou utilisé sans le consentement de EXM

No.	Revisions	Date	By/Par

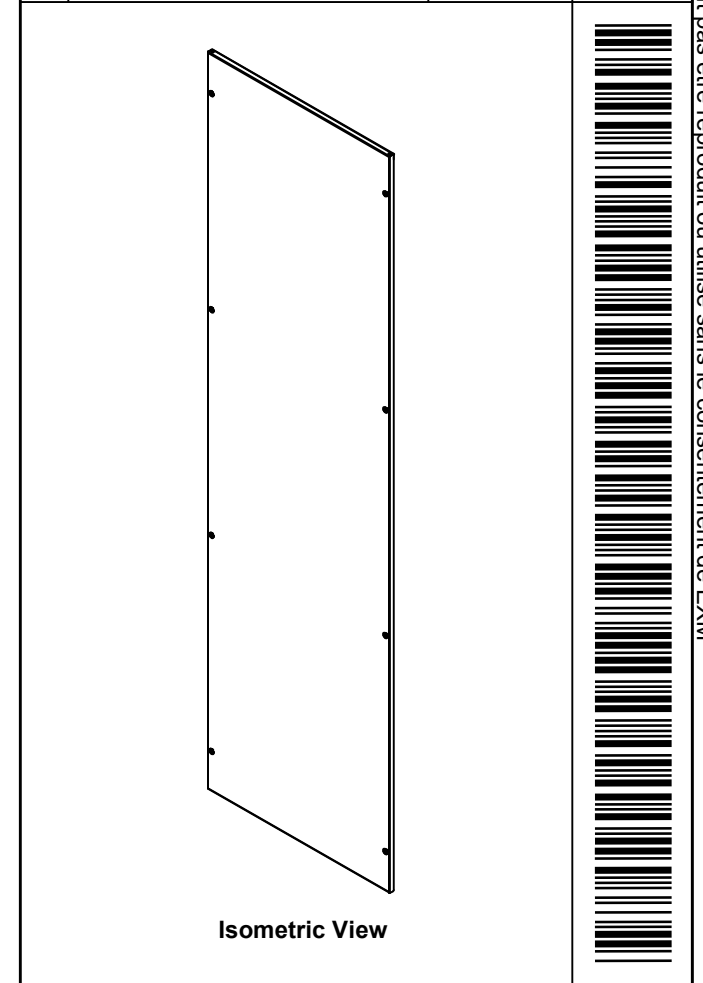

Tél: (450) 979-4373 Fax: (450) 979-4626 <a href="http://www.exmweb.com">www.exmweb.com</a>		Flatness Aplatissement
		Max 3.0mm
Projection 		Date
Customer Client	BoxCad: BoxCad	Date 10-Mar-15
Material Matière: 16 Ga Cold Rolled A1008 CS Type B		
Color Couleur: Light Grey RAL7035	Finish Fini: Textured	Detail Rev.
Description: 6500 MXC 2000mm x 600mm Left		Rev. 19
Part Number Numéro Pièce: <b>6500MXUDD201806L</b>		0 / 24

Qty	Part Number	Rev	Description
1	STK-P-03820R	0	Powder Paint (Light Grey / Rough Textured)
1	6500MXUDD201806LG	0	6500 MXC 2000mm x 600mm Left Gasket
8	STK-Q-03071	0	M6 x 16mm Machine Screw
2	STK-Q-16080	0	Ground Stud M6 x 16mm Steel
1	6500MXUDD201806L-P	0	6500 MXC 2000mm x 600mm Left Part
Parts List			

This drawing is confidential and must not be reproduced or used without the consent of EXM

Ce dessin est confidentiel et ne doit pas être reproduit ou utilisé sans le consentement de EXM

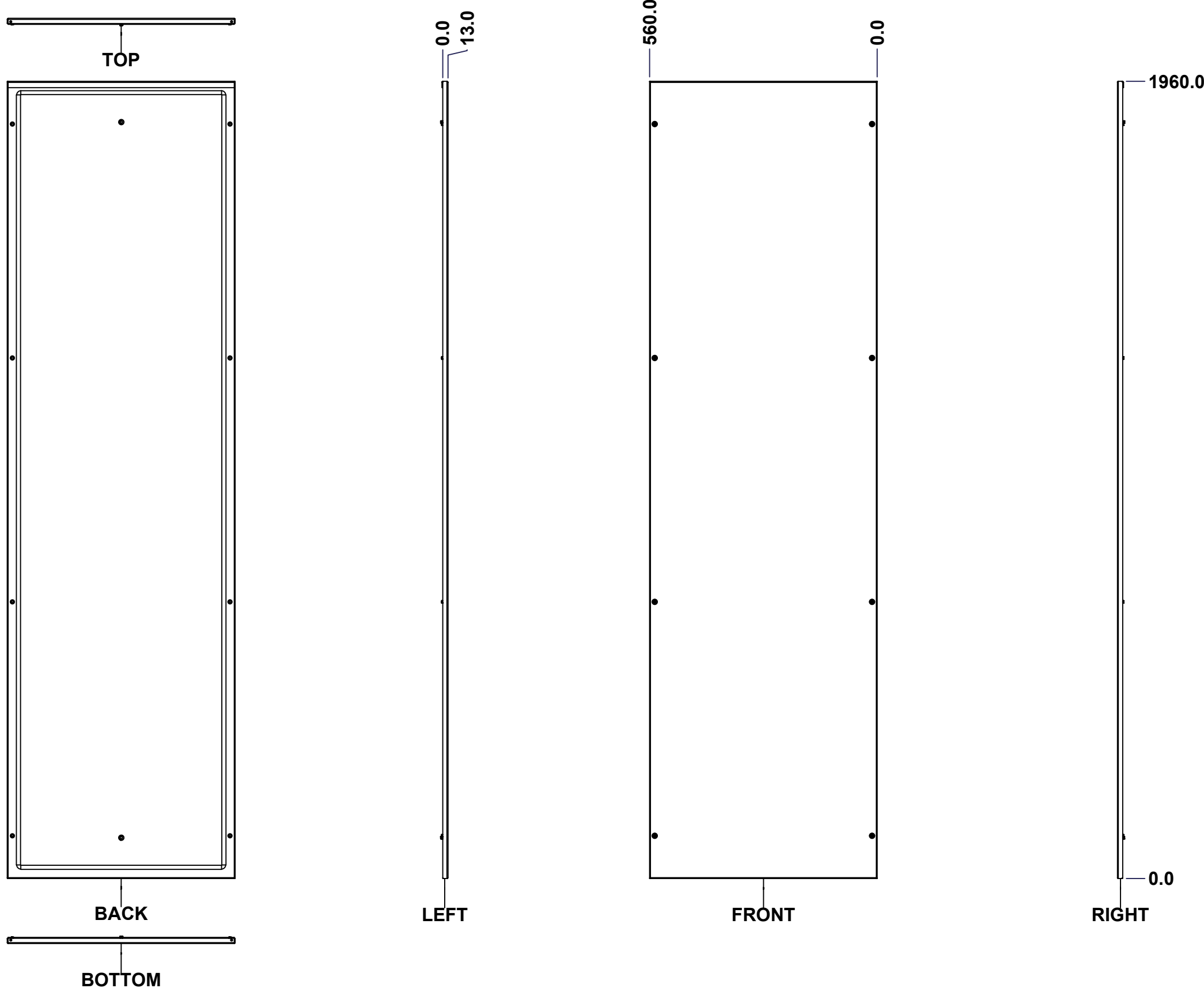

No.	Revisions	Date	By/Par

**Isometric View**

		Flatness Aplatissement Max 3.0mm	
Tél: (450) 979-4373 Fax: (450) 979-4626 <a href="http://www.exmweb.com">www.exmweb.com</a>		Projection 	
Customer Client		Date	
Drawn By / Dessiné Par: BoxCad: BoxCad		Date: 10-Mar-15	
Material / Matière: 16 Ga Cold Rolled A1008 CS Type B			
Color / Couleur: Light Grey RAL7035		Finish / Fini: Textured	
Description: 6500 MXC 2000mm x 600mm Right			Detail Rev.
Part Number / Numéro Pièce: <b>6500MXUDD201806R</b>		Rev.:	20 <b>0</b> 24

**Use gasket program path 6500 MX > 6500 MXC**

**SEE BILL OF MATERIAL ON LAST PAGE**

This drawing is confidential and must not be reproduced or used without the consent of EXM

Ce dessin est confidentiel et ne doit pas être reproduit ou utilisé sans le consentement de EXM

STANDARD FEATURES ARE NOT LISTED IN THIS HOLE TABLE			
HOLE TABLE - FRONT VIEW (CUSTOM FEATURE ONLY)			
CUT-OUT	XDIM	YDIM	DESCRIPTION
1	280.0	100.0	GND STUD M6 x 16mm (Inside)
2	280.0	1860.0	GND STUD M6 x 16mm (Inside)

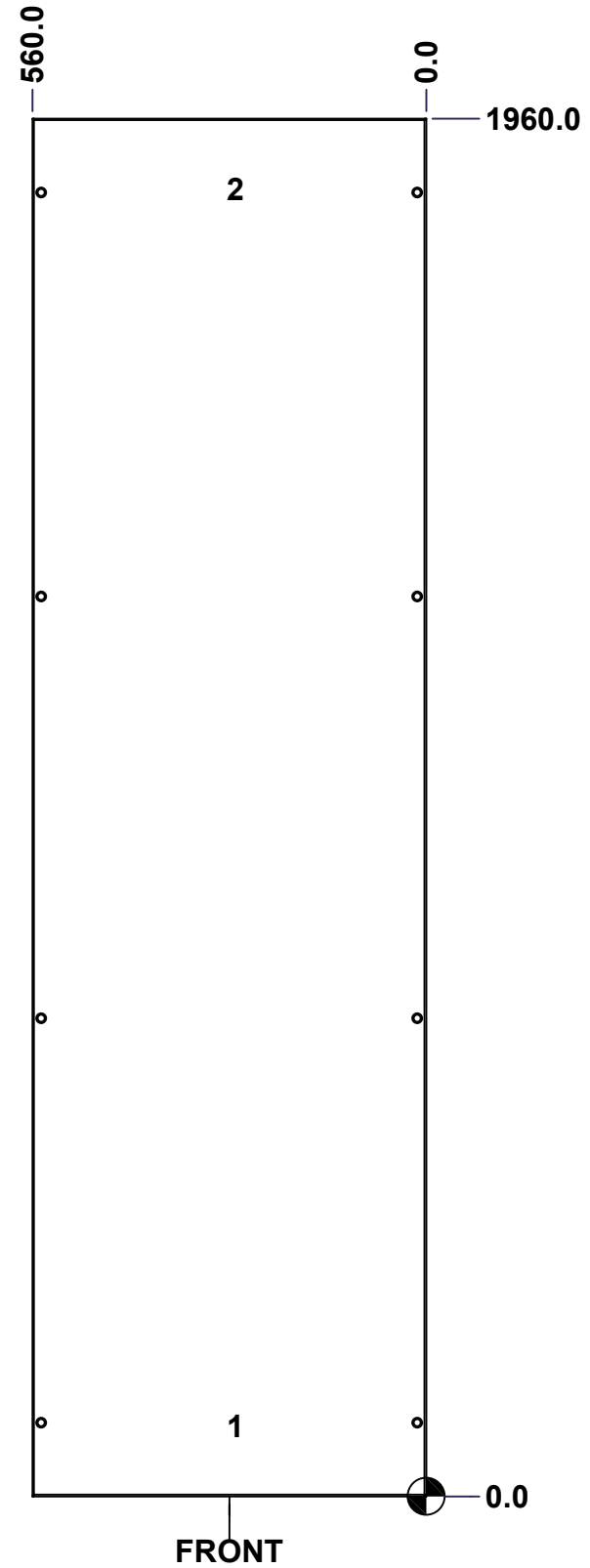

Use bending program path 6500 MX > 6500 MXC

	Description 6500 MXC 2000mm x 600mm Right	Status (NULL)
	Part Number Numéro Pièce <b>6500MXUDD201806R</b>	Rev. <b>0</b>
		21 24

This drawing is confidential and must not be reproduced or used without the consent of EXM

Ce dessin est confidentiel et ne doit pas être reproduit ou utilisé sans le consentement de EXM

No.	Revisions	Date	By/Par

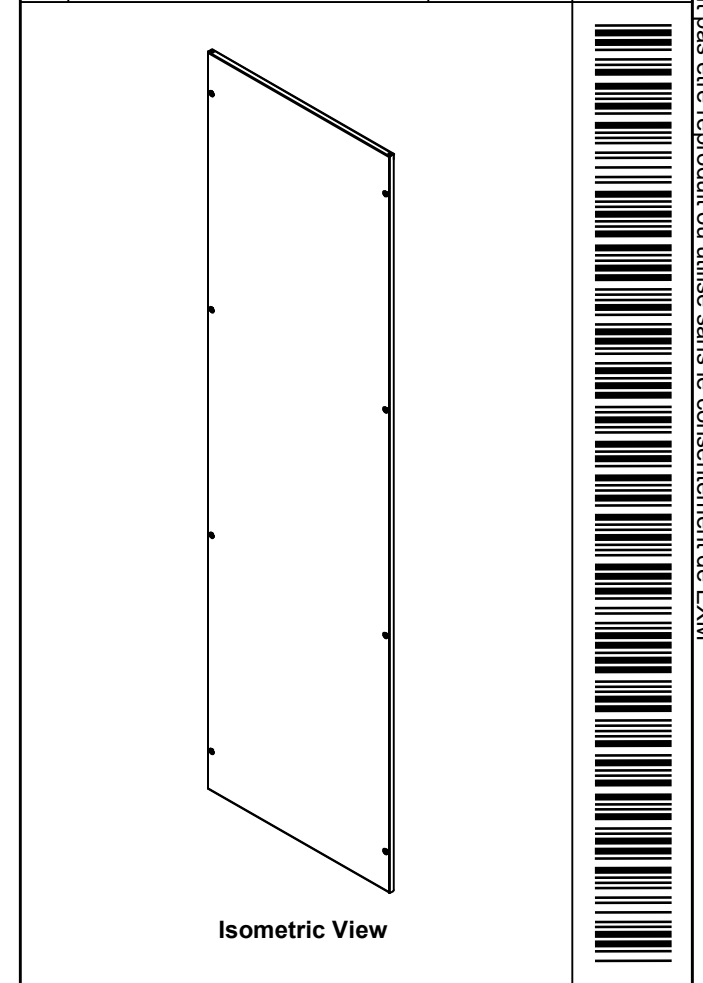

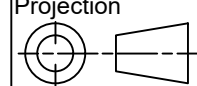
 Tél: (450) 979-4373 Fax: (450) 979-4626 <a href="http://www.exmweb.com">www.exmweb.com</a>		Flatness Aplatissement
		Max 3.0mm
Projection 		Date
Customer Client		Date 10-Mar-15
Drawn By / Dessiné Par: BoxCad: BoxCad		
Material / Matière: 16 Ga Cold Rolled A1008 CS Type B		
Color / Couleur: Light Grey RAL7035	Finish / Fini: Textured	
Description: 6500 MXC 2000mm x 600mm Right		Detail Rev.
Part Number / Numéro Pièce: <b>6500MXUDD201806R</b>		Rev. 22
		24

Qty	Part Number	Rev	Description
1	STK-P-03820R	0	Powder Paint (Light Grey / Rough Textured)
1	6500MXUDD201806RG	0	6500 MXC 2000mm x 600mm Right Gasket
8	STK-Q-03071	0	M6 x 16mm Machine Screw
2	STK-Q-16080	0	Ground Stud M6 x 16mm Steel
1	6500MXUDD201806R-P	0	6500 MXC 2000mm x 600mm Right Part
Parts List			

This drawing is confidential and must not be reproduced or used without the consent of EXM

Ce dessin est confidentiel et ne doit pas être reproduit ou utilisé sans le consentement de EXM



TOP

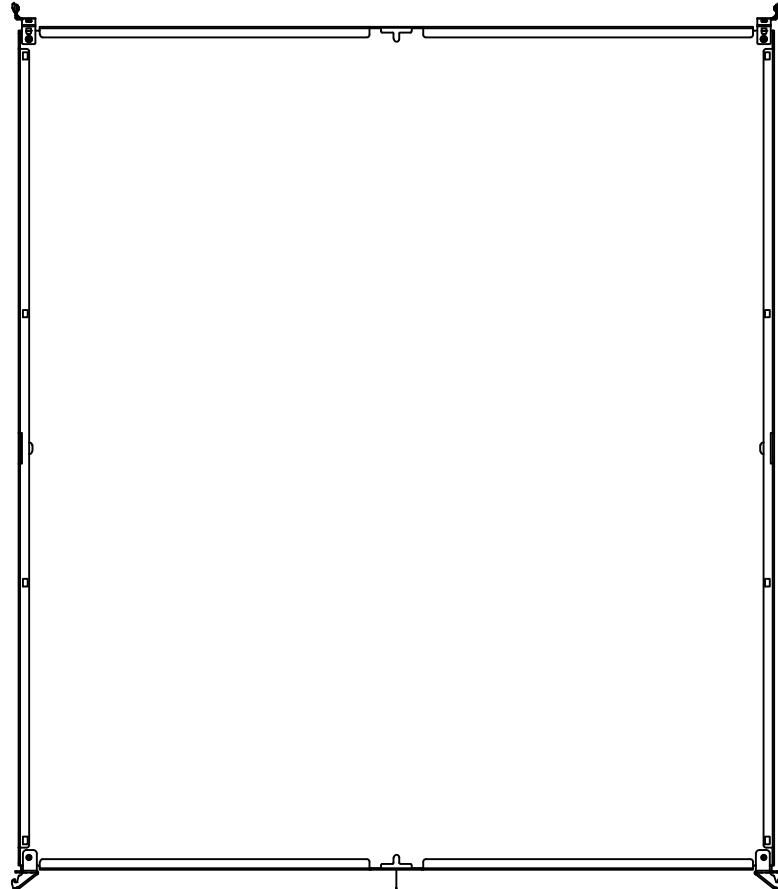

BACK

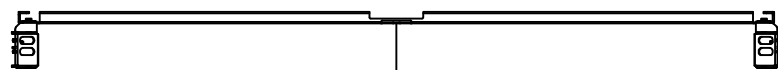

BOTTOM

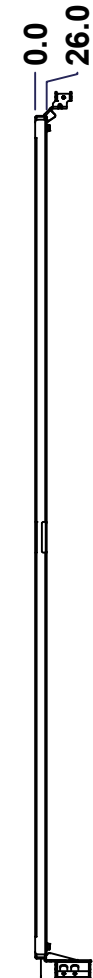

LEFT

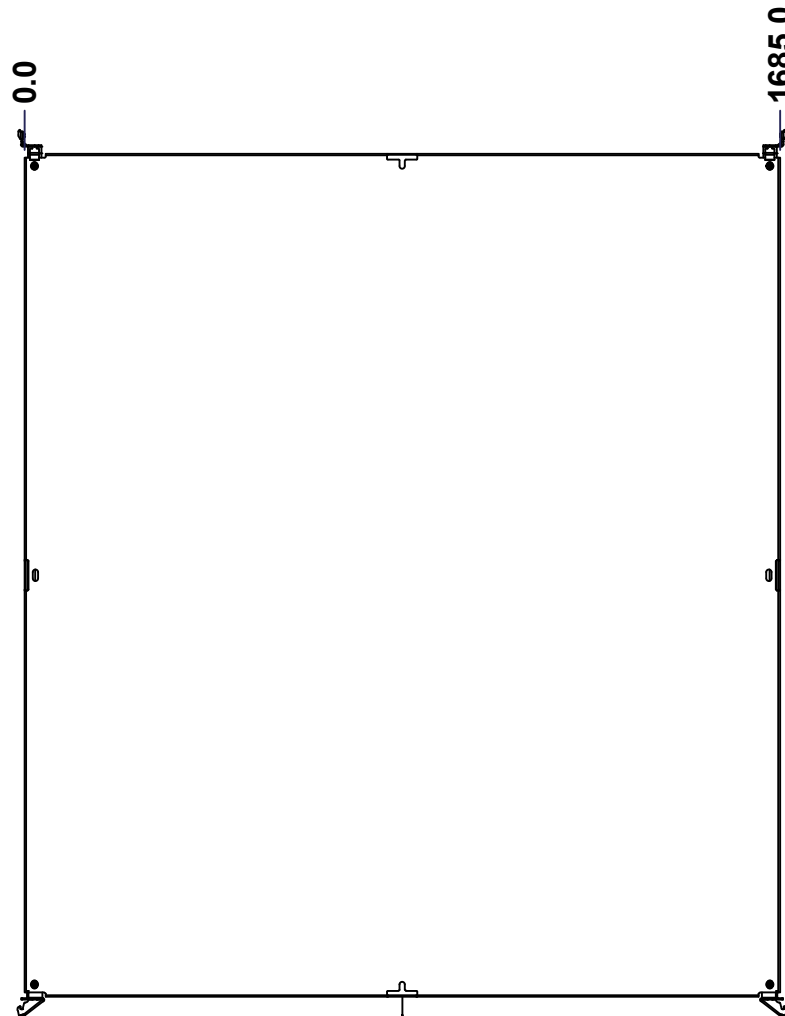

FRONT

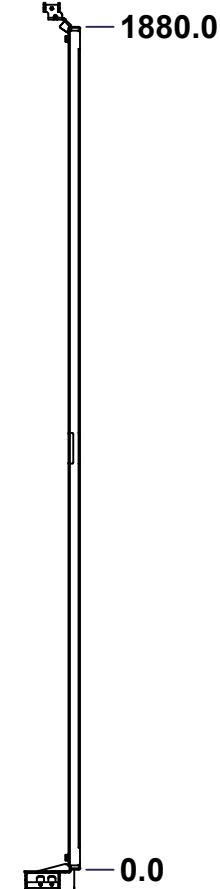

RIGHT

No.	Revisions	Date	By/Par

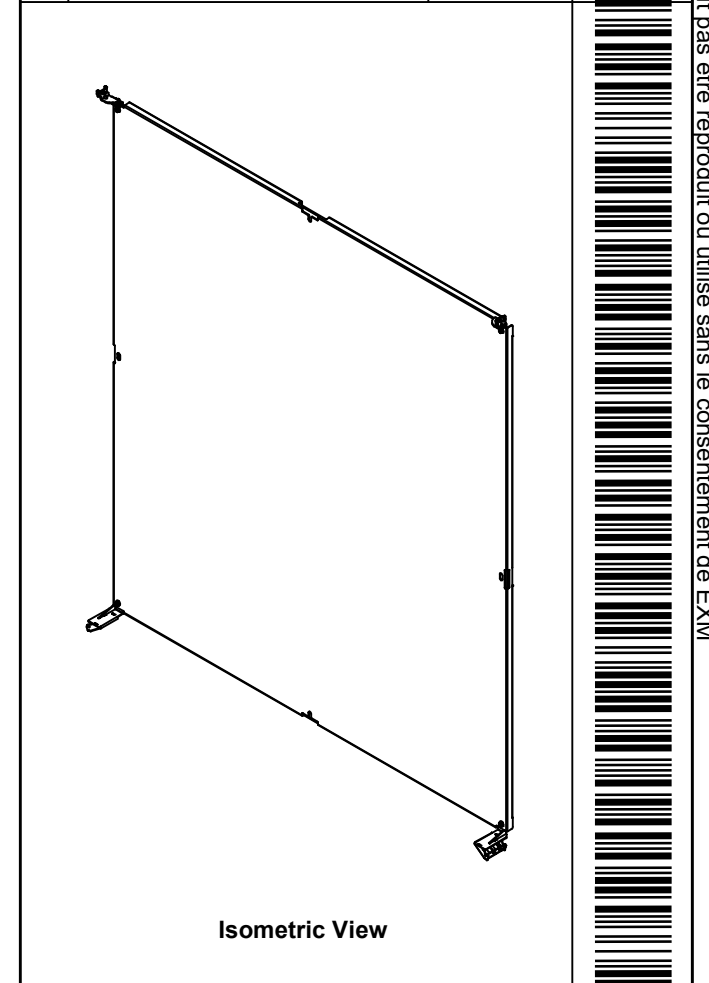

Isometric View

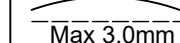
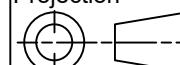

 Tél: (450) 979-4373 Fax: (450) 979-4626 <a href="http://www.exmweb.com">www.exmweb.com</a>		Flatness Aplatissement  Max 3.0mm Projection 
Customer Client	Date	
Drawn By Dessiné Par	BoxCad: BoxCad	Date 10-Mar-15
Material Matière	12 Ga Galvanized (2.5mm)	
Color Couleur	Unpainted	Finish Fini Unpainted
Description	Detail Rev.	
6500 MXM 2000mm x 1800mm Back Inner Panel		
Part Number Numéro Pièce	Rev.	
6500MXUDD201806BIP	0	23 / 24

SEE BILL OF MATERIAL ON LAST PAGE

This drawing is confidential and must not be reproduced or used without the consent of EXM

Ce dessin est confidentiel et ne doit pas être reproduit ou utilisé sans le consentement de EXM

No.	Revisions	Date	By/Par

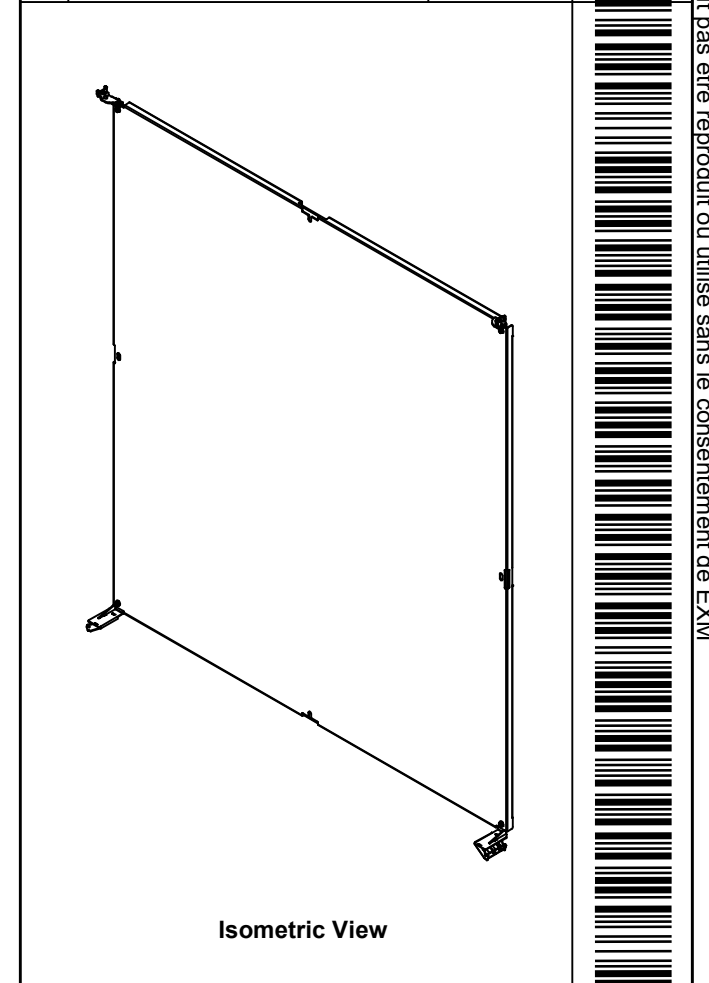

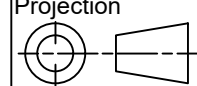
 Tél: (450) 979-4373 Fax: (450) 979-4626 <a href="http://www.exmweb.com">www.exmweb.com</a>		Flatness Aplatissement Max 3.0mm Projection 
Customer Client	Date	
Drawn By Dessiné Par	BoxCad: BoxCad	Date 10-Mar-15
Material Matière	12 Ga Galvanized (2.5mm)	
Color Couleur	Unpainted	Finish Fini Unpainted
Description 6500 MXM 2000mm x 1800mm Back Inner Panel		Detail Rev.
Part Number Numéro Pièce	Rev. 0	24
<b>6500MXUDD201806BIP</b>		24

Qty	Part Number	Rev	Description
1	STK-A-49005	5	6500 MXM - Bottom Inner Panel Support Assembly (Right)
1	STK-A-49000	5	6500 MXM - Bottom Inner Panel Support Assembly (Left)
1	STK-A-49015	0	6500MXM - Top Inner Panel Support Kit (Right)
1	STK-A-49010	0	6500MXM - Top Inner Panel Support Kit (Left)
1	6500MXUDD201806BIP-P	0	6500 MXM 2000mm x 1800mm Back Inner Panel Part
Parts List			