

This drawing is confidential and must not be reproduced or used without the consent of EXM

Ce dessin est confidentiel et ne doit pas être reproduit ou utilisé sans le consentement de EXM

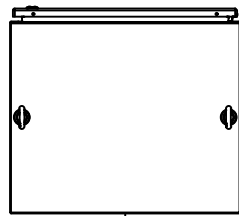

TOP

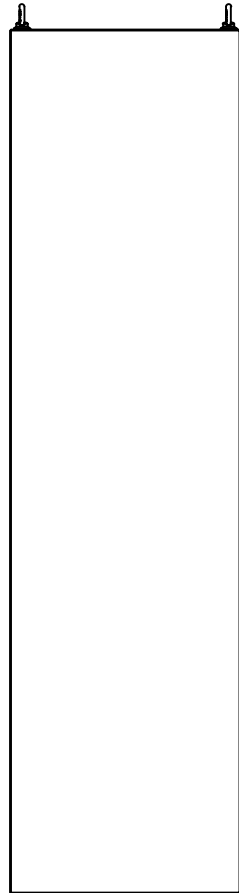

BACK

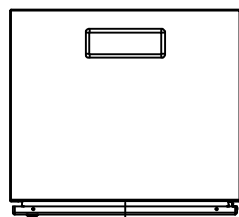

BOTTOM

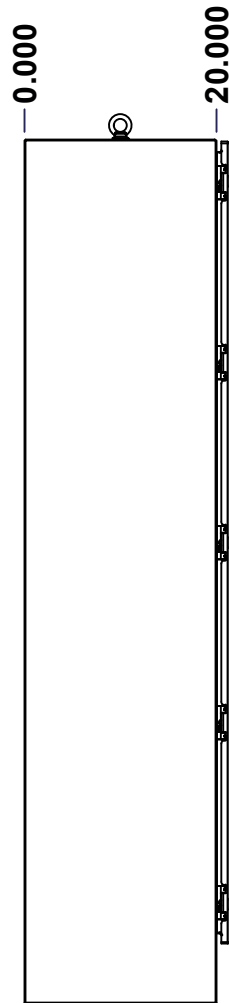

LEFT

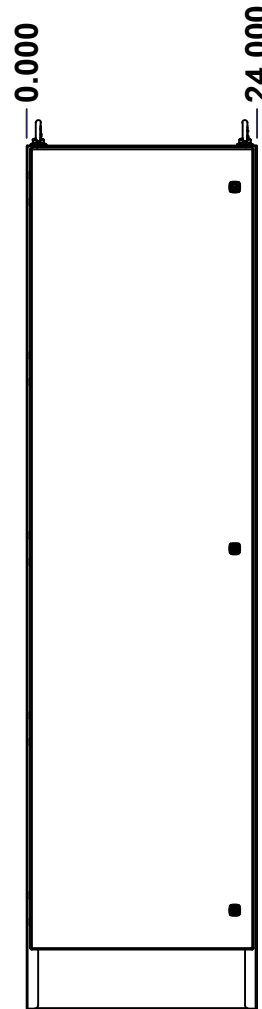

FRONT

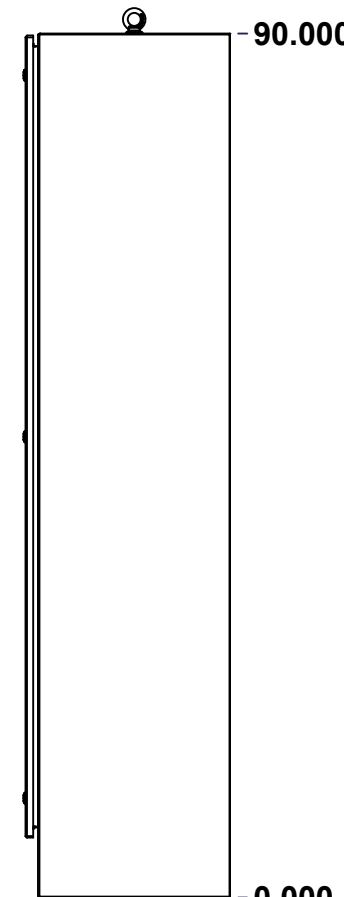

RIGHT

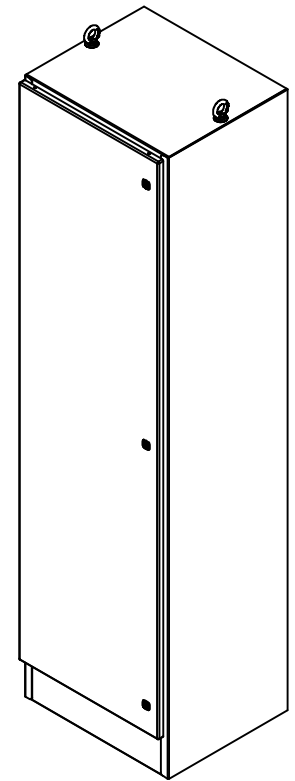

Isometric View

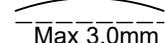
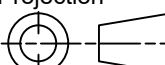

No.	Revisions	Date	By/Par

 Tél: (450) 979-4373 Fax: (450) 979-4626 www.exmweb.com		Flatness Aplatissement  Max 3.0mm Projection 
Customer Client	Date	
Drawn By Dessiné Par	BoxCad: BoxCad	Date 07-Oct-19
Material Matière	12 Ga Cold Rolled A1008 CS Type B (2.5mm)	
Color Couleur	Asa-61 Grey	Finish Fini Smooth
Description	Detail Rev.	
9412 90" x 24" x 20" Assembly		
Part Number Numéro Pièce	Rev. 0	1 / 12

SEE BILL OF MATERIAL ON LAST PAGE

9412902420

This drawing is confidential and must not be reproduced or used without the consent of EXM

Ce dessin est confidentiel et ne doit pas être reproduit ou utilisé sans le consentement de EXM

NOTE

ITEM	DESCRIPTION
1	NEMA 4, 12 Enclosure (IP66)
2	C/W Standard ground studs on box and cover
3	W/O Standard door stiffener
4	W/O Inner panel
5	C/W Standard inner panel mounting struts
6	C/W Eyebolts sold separately (Installed by EXM)
7	C/W Struts installed (Included)

No.	Revisions	Date	By/Par

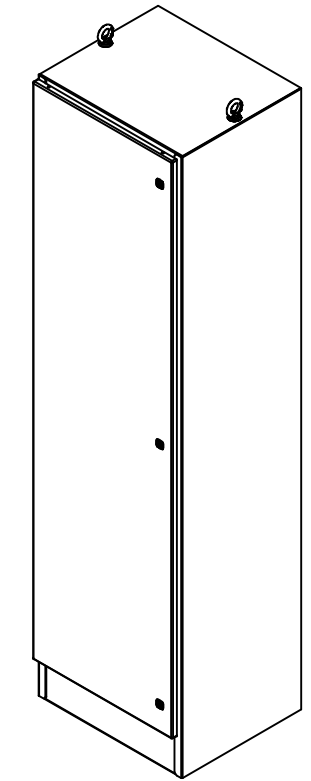

Isometric View

EXM
www.exmweb.com

Tél: (450) 979-4373
Fax: (450) 979-4626

Flatness
Aplatissement
Max 3.0mm

Projection

Customer Client	Date
Drawn By / Dessiné Par: BoxCad: BoxCad	Date: 07-Oct-19
Material / Matière: 12 Ga Cold Rolled A1008 CS Type B (2.5mm)	

Color / Couleur: Asa-61 Grey	Finish / Fini: Smooth
Description: 9412 90" x 24" x 20" Assembly	Detail Rev.
Part Number / Numéro Pièce: 9412902420	Rev. 0

PACKING		
ITEM	QTY	DESCRIPTION
Cardboard sleeve	2	Top and Bottom
Cardboard strip	2	Between back of enclosure and inner panel
Plastic bag	1	To protect cover surface and inside gasket
Cardboard corner	4	To reinforced for the plastic strap tightening
Plastic strap - Black	2	To Squeeze 2 cardboard sleeve together
Packaging label	3	White label with PN
Plastic strap- Green	2	To secure the enclosure to the wood pallet
Wood Pallet	1	2" deeper and 3" larger than enclosure size

Qty	Part Number	Rev	Description
1	9412902420GP	0	9412 Gland Plate
1	880EB14	2	Eye Bolt M14 (Pack of 2)
1	889BPS	0	Inner Panel Strut Mounting Kit
1	9412902420C	0	9412 90" x 24" Cover
1	9412902420B	0	9412 90" x 24" x 20" Body
5	STK-Q-04050-10	8	M6 x 10mm Hexagon Socket Head Machine Screw with Nyseal

Parts List

This drawing is confidential and must not be reproduced or used without the consent of EXM

Ce dessin est confidentiel et ne doit pas être reproduit ou utilisé sans le consentement de EXM

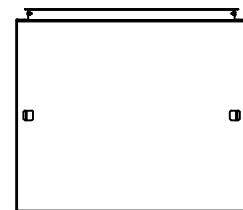

TOP



BACK

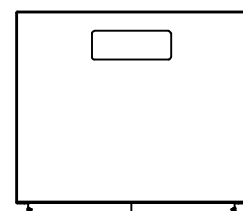

BOTTOM

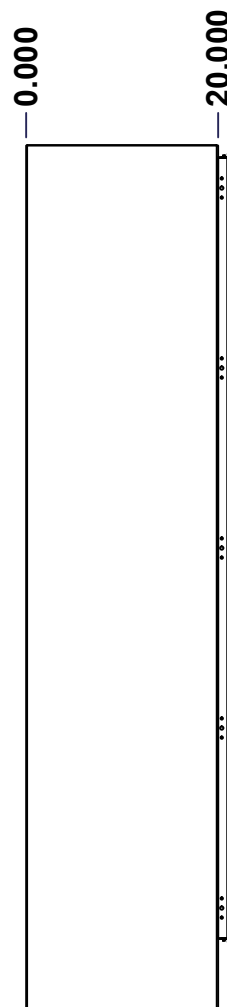

LEFT

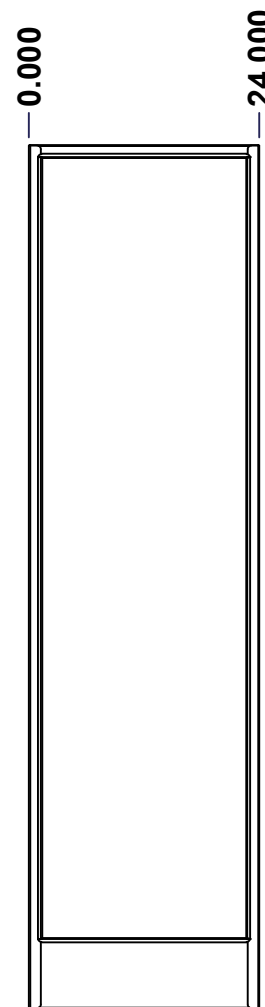

FRONT

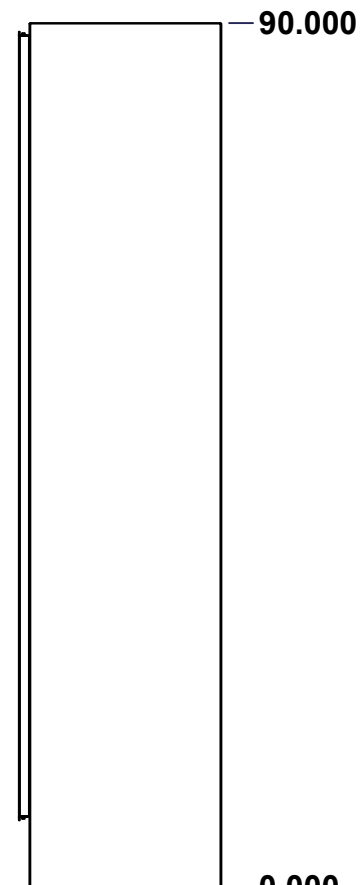

RIGHT

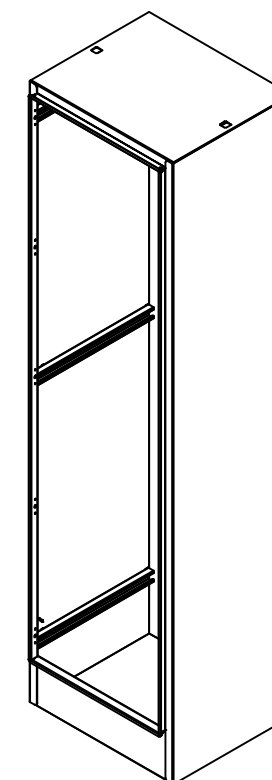

Isometric View

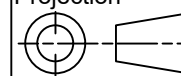

No.	Revisions	Date	By/Par

 Tél: (450) 979-4373 Fax: (450) 979-4626 www.exmweb.com		Flatness Aplatissement Max 3.0mm Projection 
Customer Client	Date	
Drawn By Dessiné Par	BoxCad: BoxCad	Date 07-Oct-19
Material Matière	12 Ga Cold Rolled A1008 CS Type B (2.5mm)	
Color Couleur	Asa-61 Grey	Finish Fini Smooth
Description	Detail Rev.	
9412 90" x 24" x 20" Body		
Part Number Numéro Pièce	Rev. 0	3 / 12
9412902420B		

SEE BILL OF MATERIAL ON LAST PAGE

This drawing is confidential and must not be reproduced or used without the consent of EXM

Ce dessin est confidentiel et ne doit pas être reproduit ou utilisé sans le consentement de EXM

STANDARD FEATURES ARE NOT LISTED IN THIS HOLE TABLE

HOLE TABLE - TOP VIEW (CUSTOM FEATURE ONLY)

CUT-OUT	XDIM	YDIM	DESCRIPTION
1	11.911	15.911	Struts CR400 17.500" (Inside)
2	11.911	16.840	STUDS M6 x 10mm (Inside)
3	20.777	15.911	STUDS M6 x 10mm (Inside)

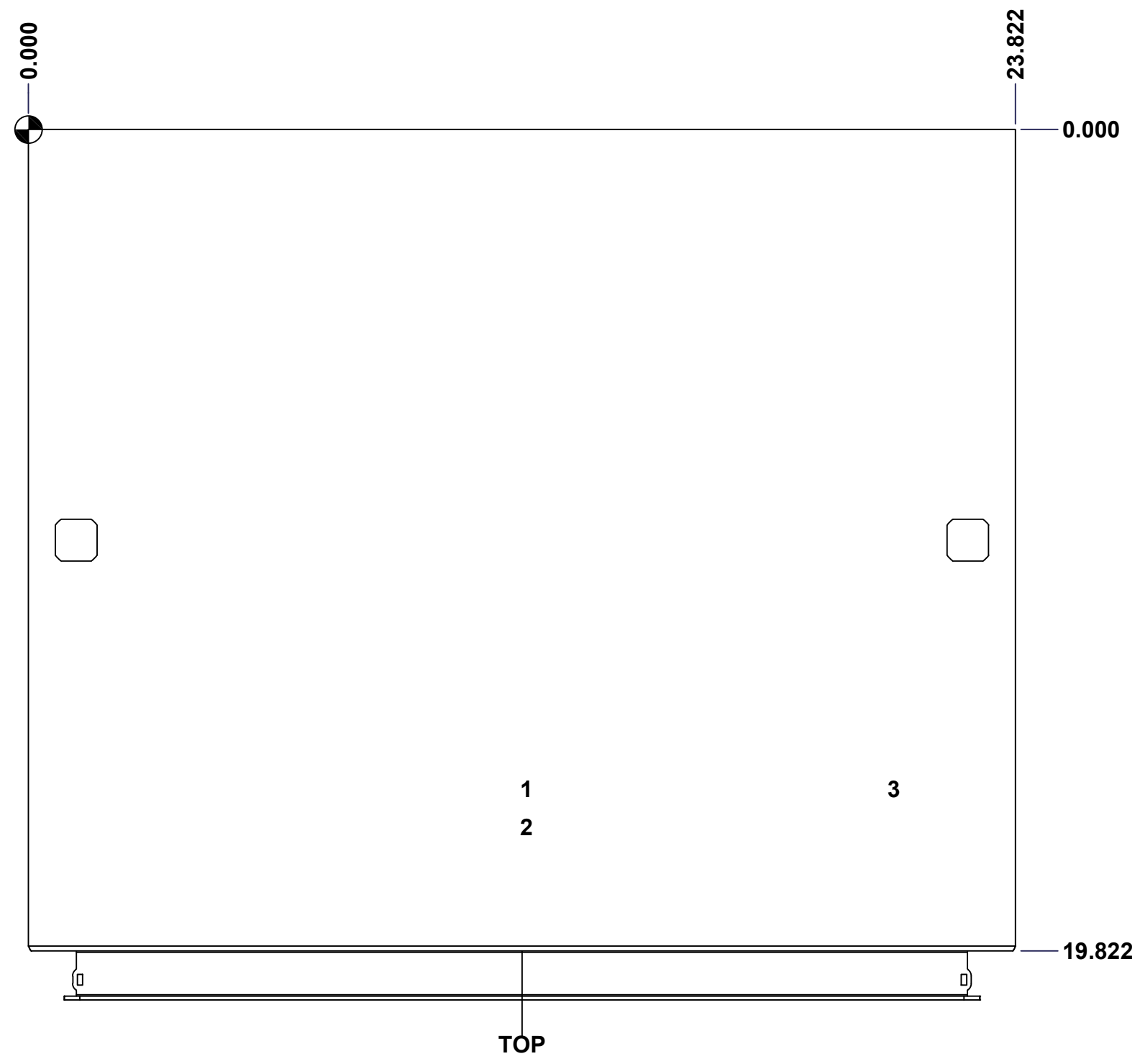

	Description	Status	
	9412 90" x 24" x 20" Body	(NULL)	
	Part Number Numéro Pièce	Rev.	4
	9412902420B	0	12

This drawing is confidential and must not be reproduced or used without the consent of EXM

Ce dessin est confidentiel et ne doit pas être reproduit ou utilisé sans le consentement de EXM

STANDARD FEATURES ARE NOT LISTED IN THIS HOLE TABLE

HOLE TABLE - RIGHT VIEW (CUSTOM FEATURE ONLY)

CUT-OUT	XDIM	YDIM	DESCRIPTION
1	6.536	84.107	STUDS M6 x 10mm (Inside)
2	13.286	84.107	STUDS M6 x 10mm (Inside)
3	6.536	7.857	STUDS M6 x 10mm (Inside)
4	13.286	7.857	STUDS M6 x 10mm (Inside)
5	6.536	45.982	STUDS M6 x 10mm (Inside)
6	13.286	45.982	STUDS M6 x 10mm (Inside)

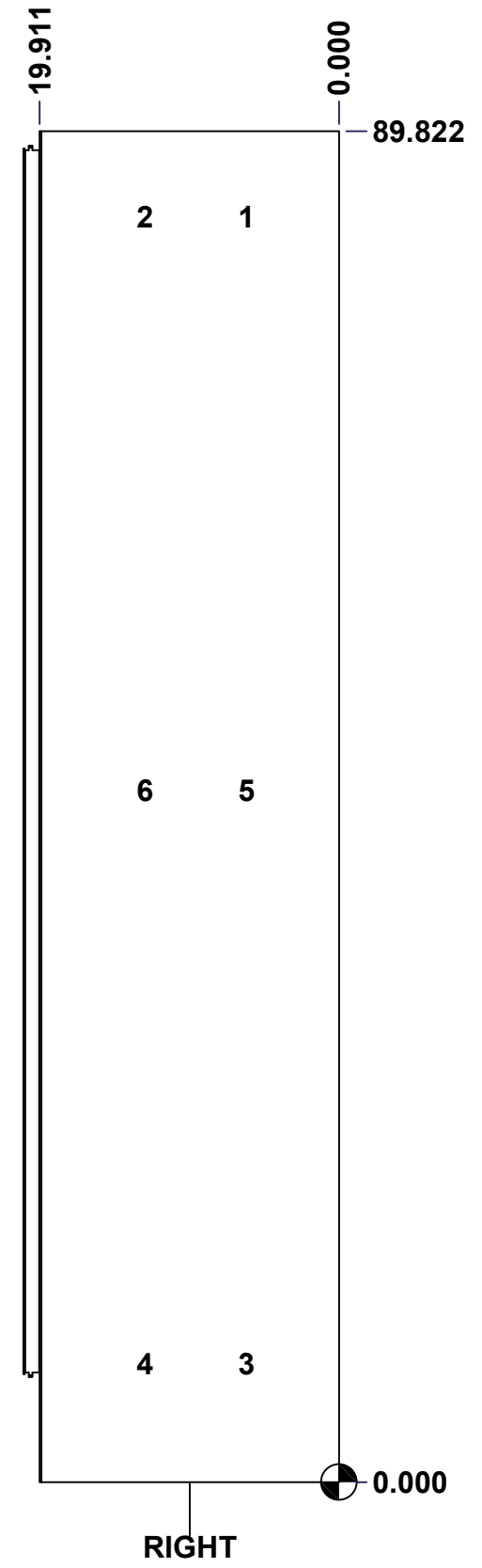

	Description 9412 90" x 24" x 20" Body	Status (NULL)
	Part Number Numéro Pièce 9412902420B	Rev. 5 0

This drawing is confidential and must not be reproduced or used without the consent of EXM

Ce dessin est confidentiel et ne doit pas être reproduit ou utilisé sans le consentement de EXM

STANDARD FEATURES ARE NOT LISTED IN THIS HOLE TABLE			
HOLE TABLE - BOTTOM VIEW (CUSTOM FEATURE ONLY)			
CUT-OUT	XDIM	YDIM	DESCRIPTION
1	7.286	3.411	GP STUD M6 x 16mm (Inside)
2	16.536	3.411	GP STUD M6 x 16mm (Inside)

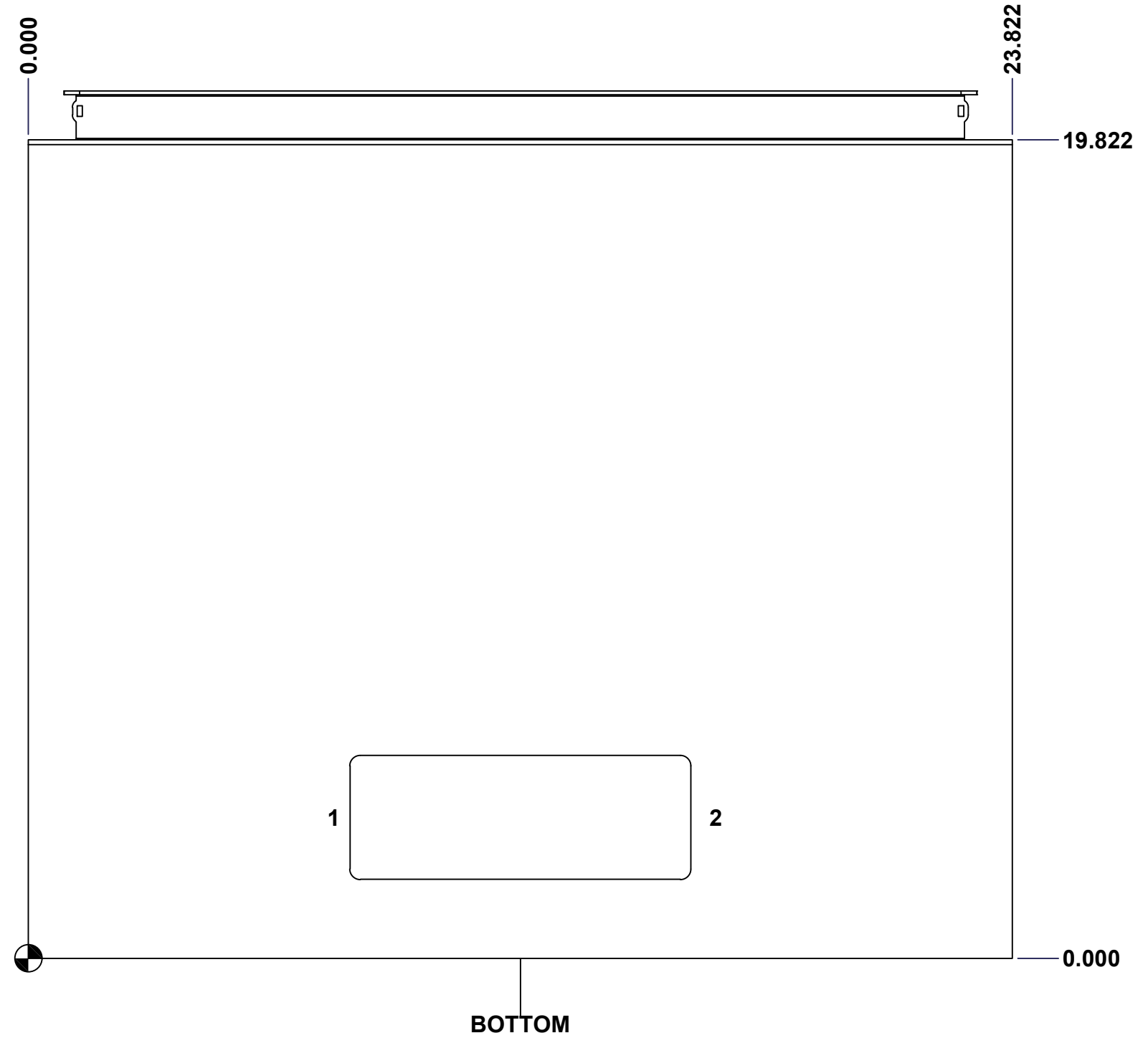

	Description 9412 90" x 24" x 20" Body	Status (NULL)
	Part Number Numéro Pièce 9412902420B	Rev. 6 0

This drawing is confidential and must not be reproduced or used without the consent of EXM

Ce dessin est confidentiel et ne doit pas être reproduit ou utilisé sans le consentement de EXM

STANDARD FEATURES ARE NOT LISTED IN THIS HOLE TABLE			
HOLE TABLE - LEFT VIEW (CUSTOM FEATURE ONLY)			
CUT-OUT	XDIM	YDIM	DESCRIPTION
1	18.411	11.286	GND STUD M6 x 16mm (Inside)
2	6.536	84.107	STUDS M6 x 10mm (Inside)
3	13.286	84.107	STUDS M6 x 10mm (Inside)
4	6.536	7.857	STUDS M6 x 10mm (Inside)
5	13.286	7.857	STUDS M6 x 10mm (Inside)
6	6.536	45.982	STUDS M6 x 10mm (Inside)
7	13.286	45.982	STUDS M6 x 10mm (Inside)

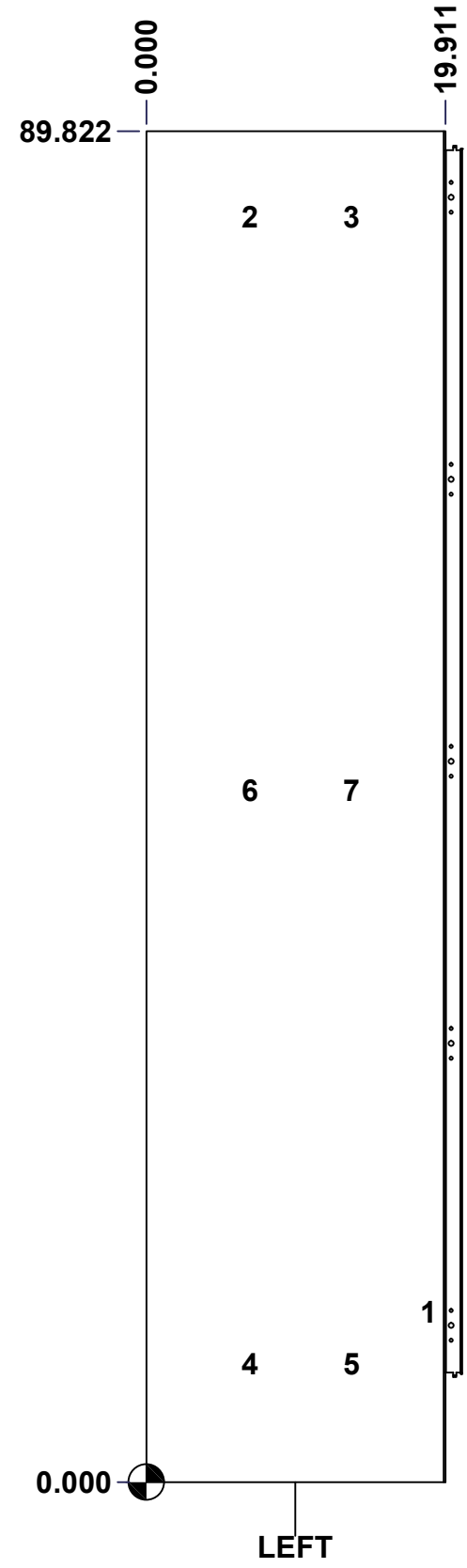

	Description 9412 90" x 24" x 20" Body	Status (NULL)
	Part Number Numéro Pièce 9412902420B	Rev. 7 0

This drawing is confidential and must not be reproduced or used without the consent of EXM

Ce dessin est confidentiel et ne doit pas être reproduit ou utilisé sans le consentement de EXM

No.	Revisions	Date	By/Par

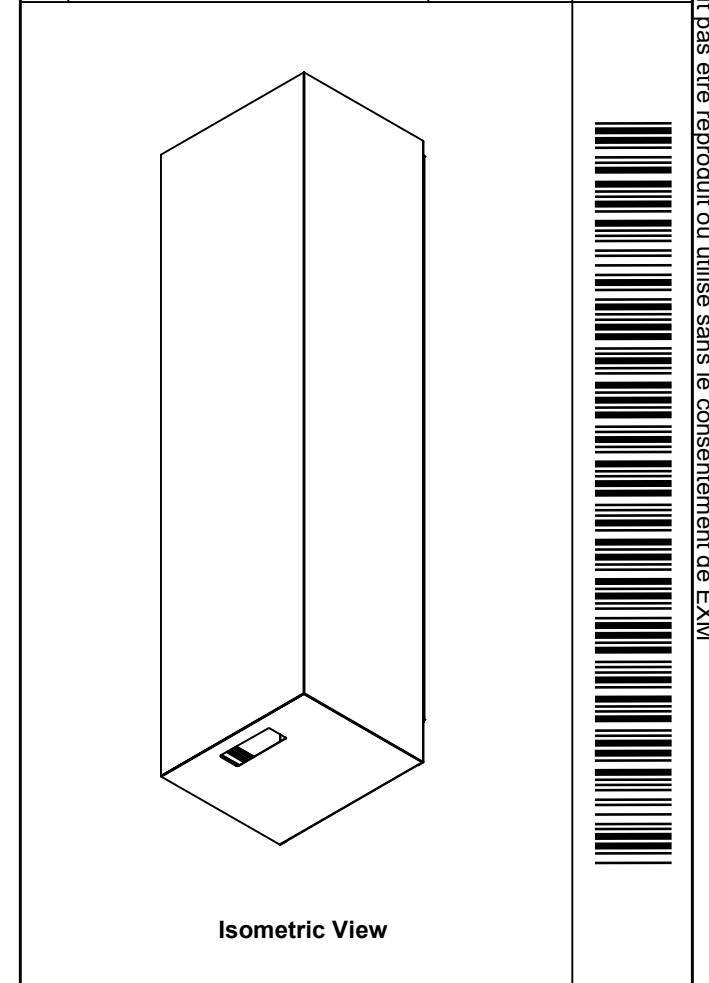

Isometric View

14	STK-Q-16030	0	Stud M6 x 10mm Steel
1	9412902420_CR400MS_1 7.5	0	Commercial Roll Mild Steel (17.5in long)
2	STK-Q-74910	0	Eyebolt Lifting Angle (15.500")
1	STK-P-02400S	0	Powder Paint (Asa-61 Grey / Smooth)
3	STK-Q-52200-20	2	Sasco Strut S5 (17.500" Long)
3	STK-Q-52250-20	2	Sasco Strut S5 (19.500" Long)
1	9412902420BT-P	0	9412 24" x 20" Bottom Part
1	9412902420T-P	0	9412 24" x 20" Top Part
1	9412902420RS-P	0	9412 90" x 24" Right Part
1	9412902420LS-P	0	9412 90" x 24" Left Part
1	9412902420B-P	0	9412 90" x 24" Back Part
3	STK-Q-16080	0	Ground Stud M6 x 16mm Steel
Qty	Part Number	Rev	Description
Parts List			

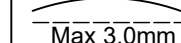
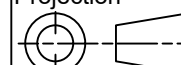
 Tél: (450) 979-4373 Fax: (450) 979-4626 www.exmweb.com		Flatness Aplatissement  Max 3.0mm
Projection 		Date
Customer Client		Date 07-Oct-19
Drawn By Dessiné Par BoxCad: BoxCad		Date
Material Matière 12 Ga Cold Rolled A1008 CS Type B (2.5mm)		
Color Couleur Asa-61 Grey	Finish Fini Smooth	
Description 9412 90" x 24" x 20" Body		Detail Rev.
Part Number Numéro Pièce 9412902420B		Rev. 8 0
		12

This drawing is confidential and must not be reproduced or used without the consent of EXM

Ce dessin est confidentiel et ne doit pas être reproduit ou utilisé sans le consentement de EXM

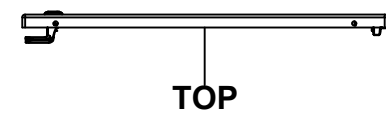

TOP

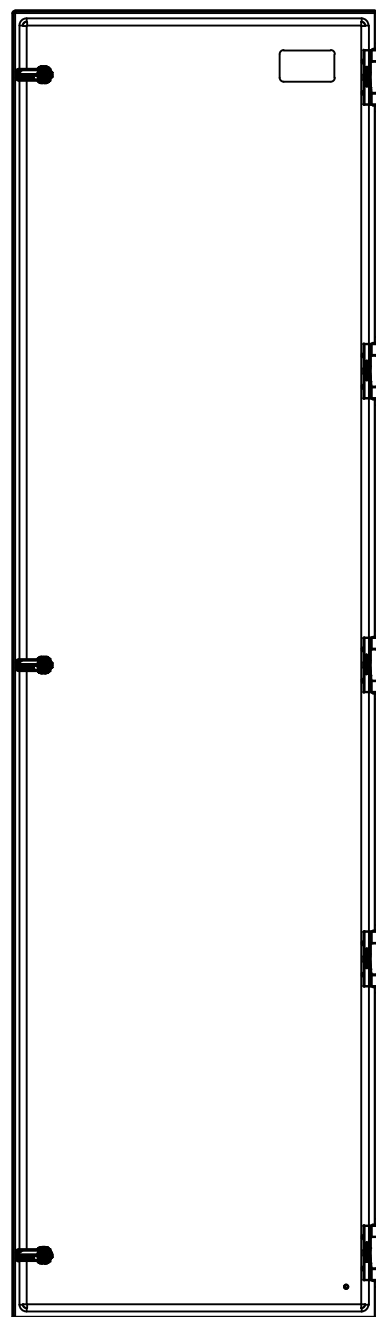

BACK

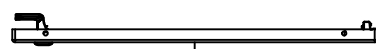

BOTTOM

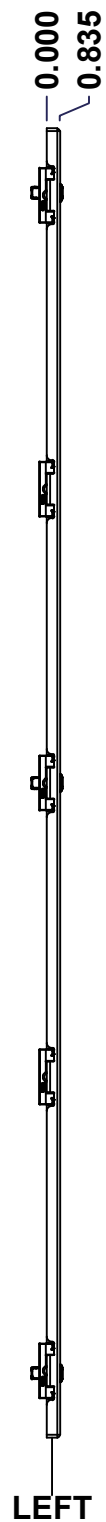

LEFT

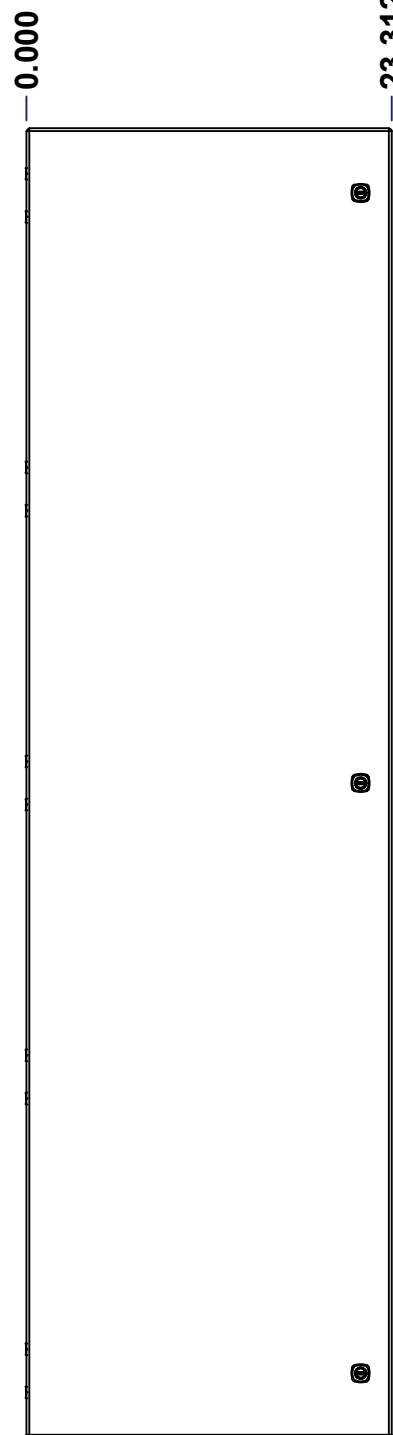

FRONT

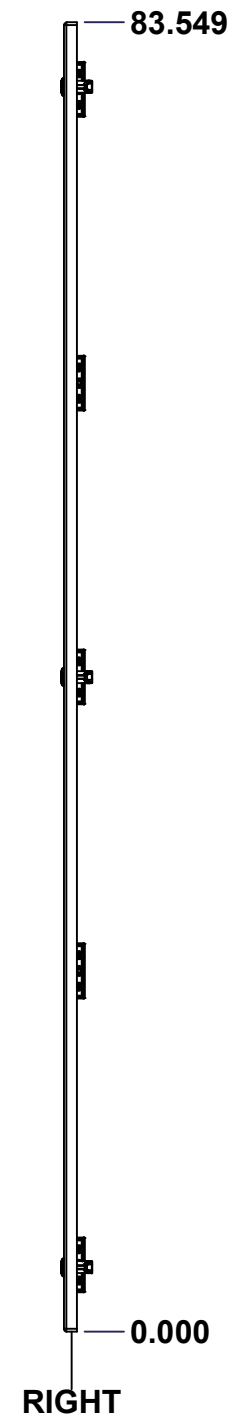

RIGHT

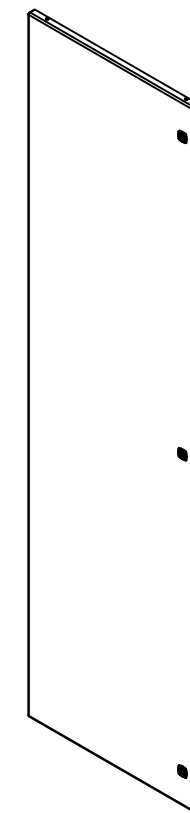

Isometric View

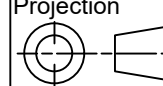

No.	Revisions	Date	By/Par

 Tél: (450) 979-4373 Fax: (450) 979-4626 www.exmweb.com		Flatness Aplatissement Max 3.0mm Projection 
Customer Client	Date	
Drawn By Dessiné Par	BoxCad: BoxCad	Date 07-Oct-19
Material Matière	12 Ga Cold Rolled A1008 CS Type B (2.5mm)	
Color Couleur	Asa-61 Grey	Finish Fini Smooth
Description	Detail Rev.	
9412 90" x 24" Cover		
Part Number Numéro Pièce	Rev.	9
9412902420C	0	12

SEE BILL OF MATERIAL ON LAST PAGE

This drawing is confidential and must not be reproduced or used without the consent of EXM

Ce dessin est confidentiel et ne doit pas être reproduit ou utilisé sans le consentement de EXM

STANDARD FEATURES ARE NOT LISTED IN THIS HOLE TABLE

HOLE TABLE - FRONT VIEW (CUSTOM FEATURE ONLY)

CUT-OUT	XDIM	YDIM	DESCRIPTION
1	2.000	2.118	GND STUD M6 x 16mm (Inside)
2	21.312	79.430	LOCK 889 SCQ4-SL @ 0.0°
3	21.312	41.774	LOCK 889 SCQ4-SL @ 0.0°
4	21.312	4.118	LOCK 889 SCQ4-SL @ 0.0°

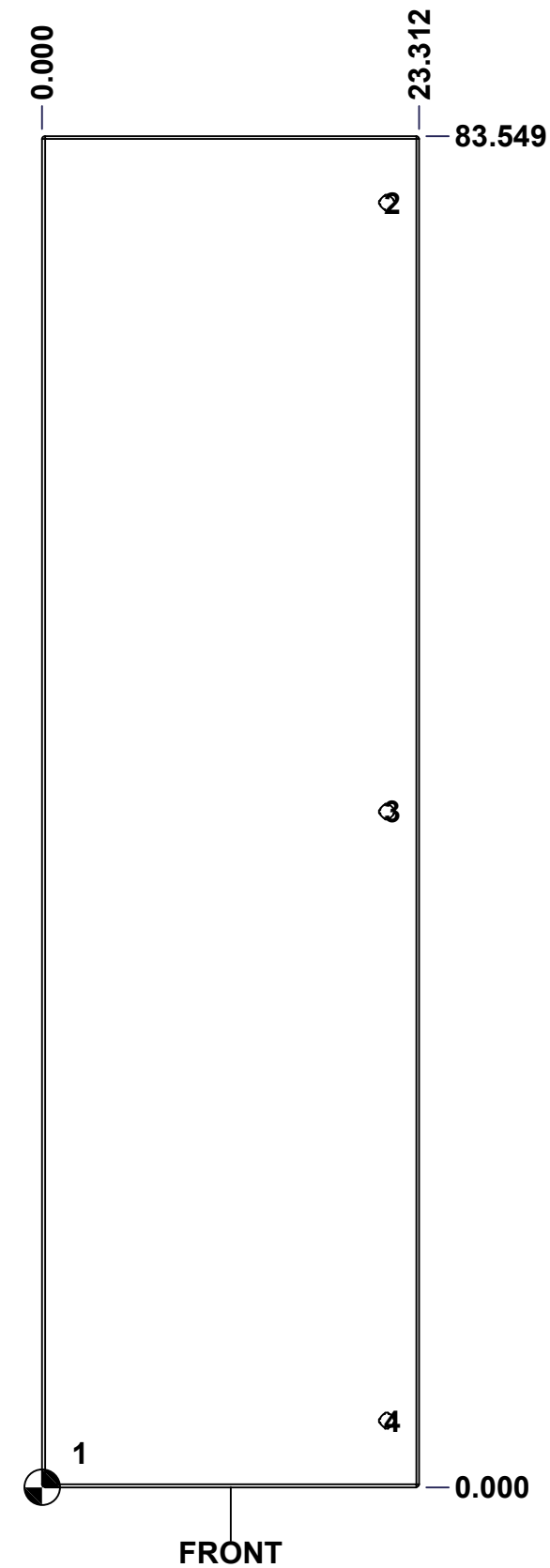

	Description	Status	
	9412 90" x 24" Cover	(NULL)	
	Part Number Numéro Pièce	Rev.	10
	9412902420C	0	12

This drawing is confidential and must not be reproduced or used without the consent of EXM

Ce dessin est confidentiel et ne doit pas être reproduit ou utilisé sans le consentement de EXM

No.	Revisions	Date	By/Par

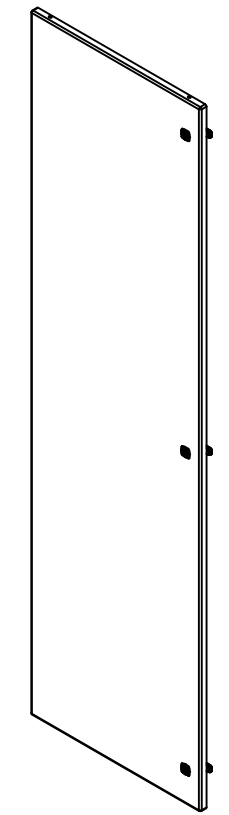

Isometric View

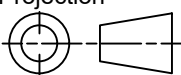

 Tél: (450) 979-4373 Fax: (450) 979-4626 www.exmweb.com		Flatness Aplatissement Max 3.0mm Projection 
Customer Client	Date	
Drawn By / Dessiné Par: BoxCad: BoxCad	Date: 07-Oct-19	
Material / Matière: 12 Ga Cold Rolled A1008 CS Type B (2.5mm)	Color / Couleur: Asa-61 Grey	
Description: 9412 90" x 24" Cover		Finish / Fini: Smooth
Part Number / Numéro Pièce: 9412902420C	Rev.:	11 / 12

QTY	Part Number	Rev	Description
1	STK-Q-16080	0	Ground Stud M6 x 16mm Steel
1	STK-P-02400S	0	Powder Paint (Asa-61 Grey / Smooth)
1	STK-S-00100	0	3.5" x 2" Silver Milar Flexcon Sticker
1	9412902420G	0	9412 90" x 24" Cover Gasket
1	9412902420C-P	0	9412 90" x 24" Cover Part
5	STK-K-09860	7	Cabinet Hinge with Captive Pins
3	STK-K-12580	0	9412 1/4 Turn Lock
Parts List			

All knockouts are actual size / Les disques défonçables sont grandeur réel
 All dimensions are before paint / Toutes les dimensions sont avant peinture

This drawing is confidential and must not be reproduced or used without the consent of EXM

Ce dessin est confidentiel et ne doit pas être reproduit ou utilisé sans le consentement de EXM

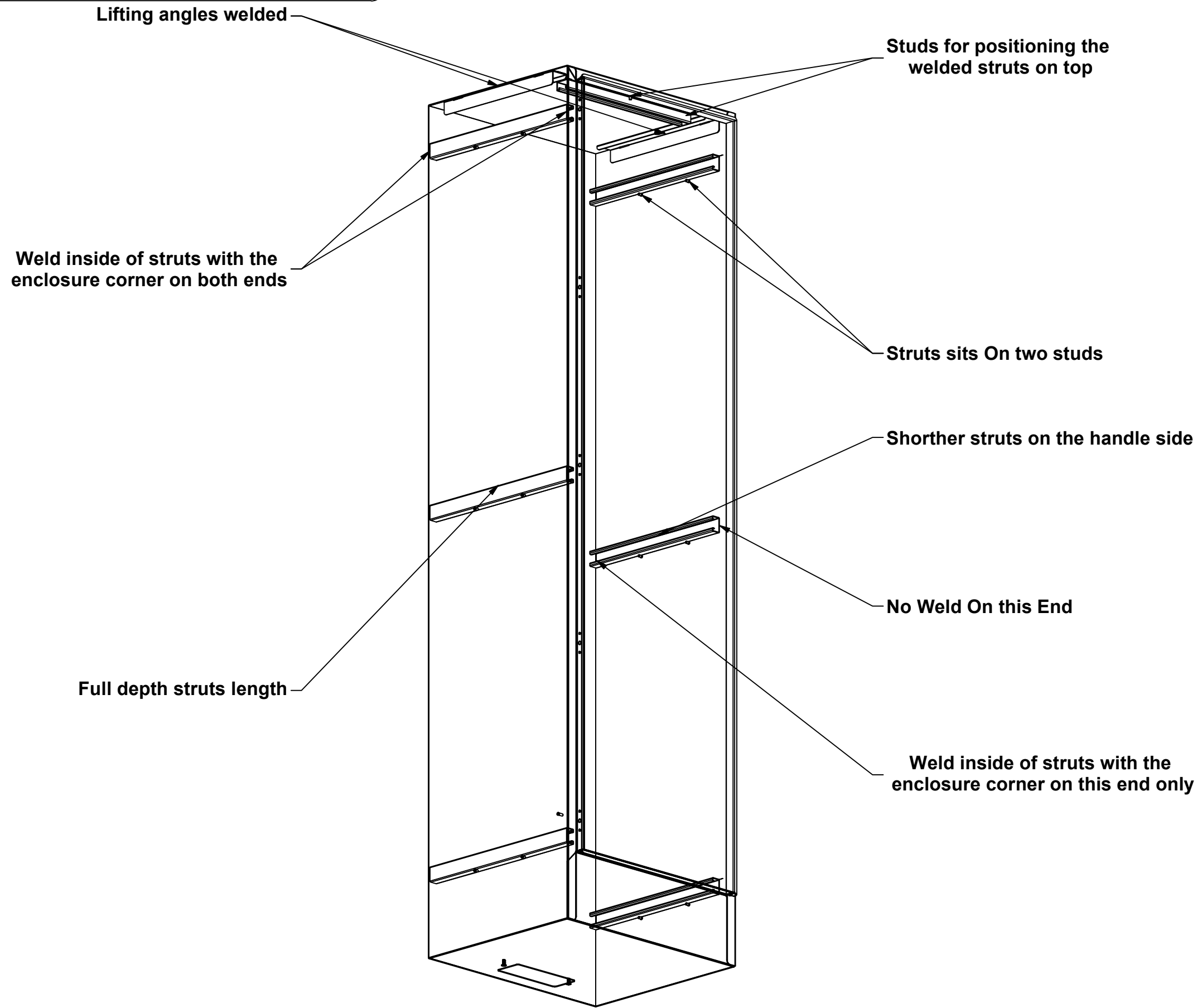

No.	Revisions	Date	By/Par

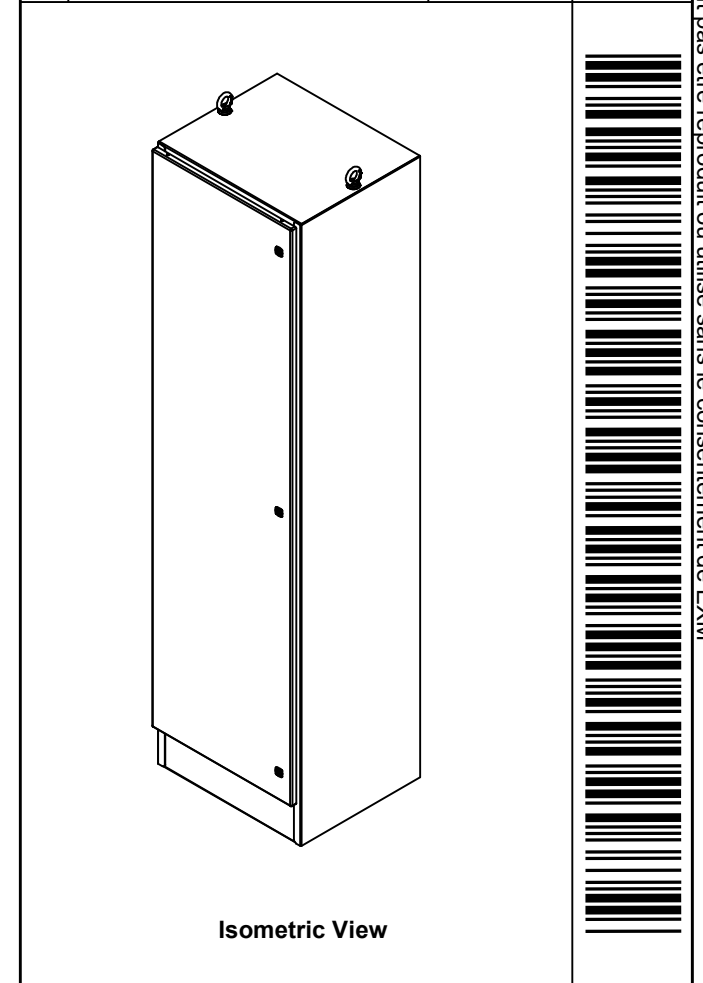

 Tél: (450) 979-4373 Fax: (450) 979-4626 www.exmweb.com		Flatness Aplatissement
		Max 3.0mm
Customer Client		Date
Drawn By Dessiné Par BoxCad		Date 11-Aug-05
Material Matière 12 Ga Cold Rolled A1008 CS Type B (2.5mm)		
Color Couleur Asa-61 Grey	Finish Fini Smooth	
Description 9412 90" x 24" x 20" Assembly		Detail Rev.
Part Number Numéro Pièce 9412 Welding Details		Rev. 12 0 12