

This drawing is confidential and must not be reproduced or used without the consent of EXM

Ce dessin est confidentiel et ne doit pas être reproduit ou utilisé sans le consentement de EXM

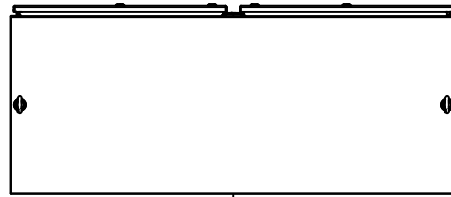

TOP

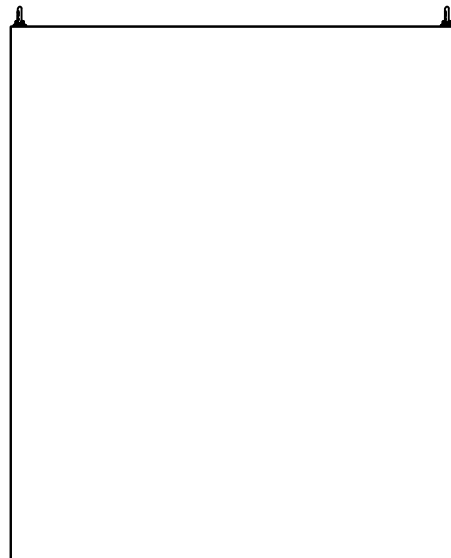

BACK

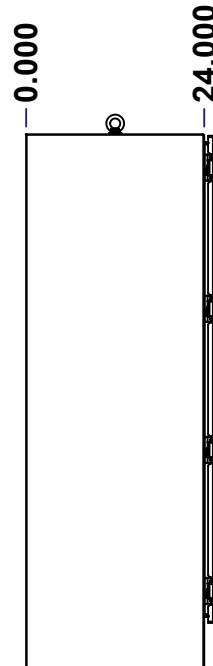

LEFT

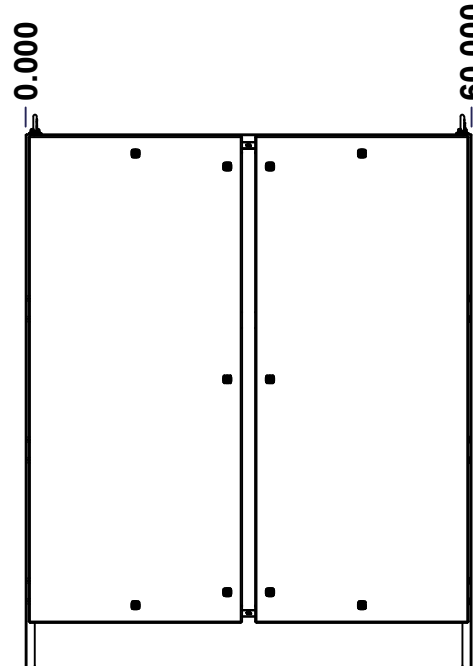

FRONT

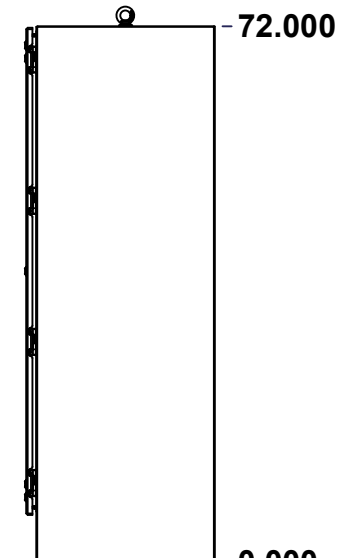

RIGHT



BOTTOM

No.	Revisions	Date	By/Par

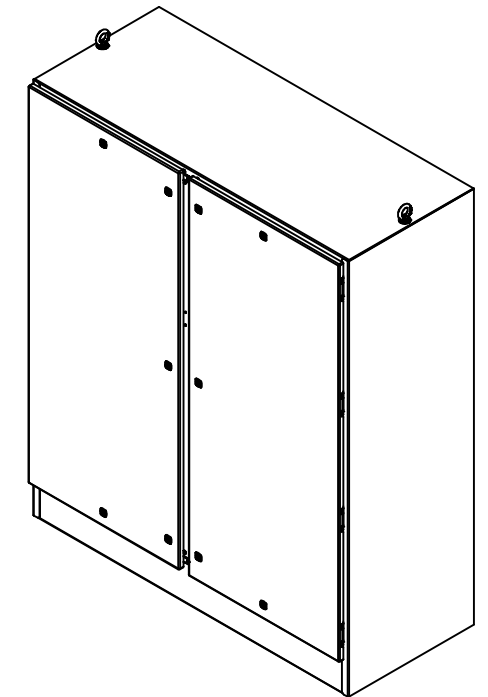

Isometric View



Tél: (450) 979-4373
 Fax: (450) 979-4626
www.exmweb.com

Flatness
Aplatissement

Max 3.0mm

Projection

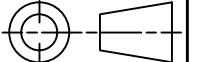

Customer Client	Date
Drawn By / Dessiné Par: BoxCad: BoxCad	Date: 10/10/2019
Material / Matière: 12 Ga Cold Rolled A1008 CS Type B (2.5mm)	

Color / Couleur: Asa-61 Grey	Finish / Fini: Smooth
------------------------------	-----------------------

Description: 9412DD 72" x 60" x 24" Assembly	Detail Rev.
--	-------------

Part Number / Numéro Pièce: 9412DD726024	Rev. 0	1
--	--------	---

SEE BILL OF MATERIAL ON LAST PAGE

This drawing is confidential and must not be reproduced or used without the consent of EXM

Ce dessin est confidentiel et ne doit pas être reproduit ou utilisé sans le consentement de EXM

NOTE	
ITEM	DESCRIPTION
1	NEMA 4, 12 Enclosure (IP66)
2	C/W Standard ground studs on box and cover
3	W/O Standard door stiffener
4	W/O Inner panel
5	C/W Standard inner panel mounting struts
6	C/W Eyebolts sold separately (Installed by EXM)
7	C/W Struts installed (Included)
8	C/W Interlock Kit (Installed by EXM)

No.	Revisions	Date	By/Par

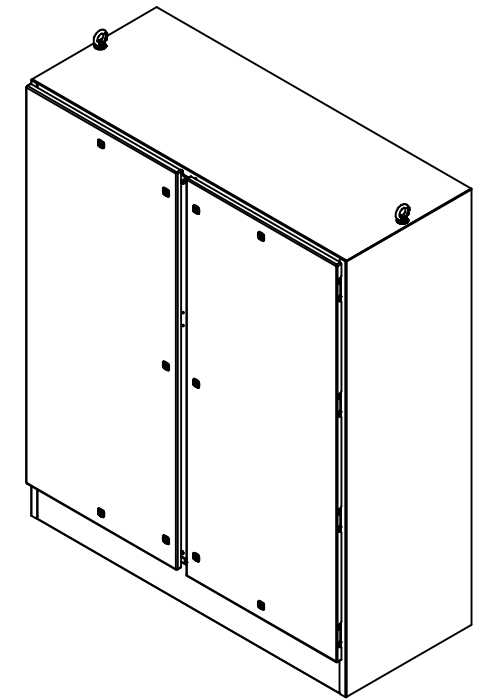

Isometric View



Tél: (450) 979-4373
 Fax: (450) 979-4626
www.exmweb.com

Flatness
Aplatissement

Max 3.0mm

Projection

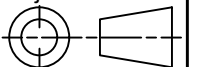

Customer Client	Date
Drawn By Dessiné Par: BoxCad: BoxCad	Date: 10/10/2019

Material Matière	12 Ga Cold Rolled A1008 CS Type B (2.5mm)
------------------	---

Color Couleur	Asa-61 Grey	Finish Fini	Smooth
---------------	-------------	-------------	--------

Description	9412DD 72" x 60" x 24" Assembly	Detail Rev.
-------------	---------------------------------	-------------

Part Number Numéro Pièce	9412DD726024	Rev.	0	2
--------------------------	--------------	------	---	---

PACKING		
ITEM	QTY	DESCRIPTION
Cardboard sleeve	2	Top and Bottom
Cardboard strip	2	Between back of enclosure and inner panel
Plastic bag	1	To protect cover surface and inside gasket
Cardboard corner	4	To reinforced for the plastic strap tightening
Plastic strap - Black	2	To Squeeze 2 cardboard sleeve together
Packaging label	3	White label with PN
Plastic strap- Green	2	To secure the enclosure to the wood pallet
Wood Pallet	1	2" deeper and 3" larger than enclosure size

Qty	Part Number	Rev	Description
1	880INTI	4	880 INTI - Interlock Post Kit
1	880EB14	2	Eye Bolt M14 (Pack of 2)
1	889BPS	0	Inner Panel Strut Mounting Kit
1	9412DD726024FD	0	9412DD 72" x 60" Flange Door
1	9412DD726024LD	0	9412DD 72" x 60" Lock Door
1	9412DD726024B	0	9412DD 72" x 60" x 24" Body
2	9412DD726024GP	0	9412DD Gland Plate
8	STK-Q-04050-10	8	M6 x 10mm Hexagon Socket Head Machine Screw with Nyseal
Parts List			

This drawing is confidential and must not be reproduced or used without the consent of EXM

Ce dessin est confidentiel et ne doit pas être reproduit ou utilisé sans le consentement de EXM

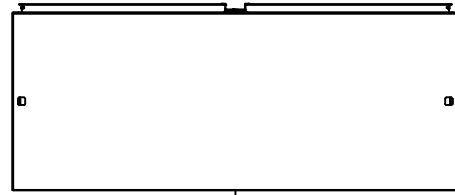

TOP

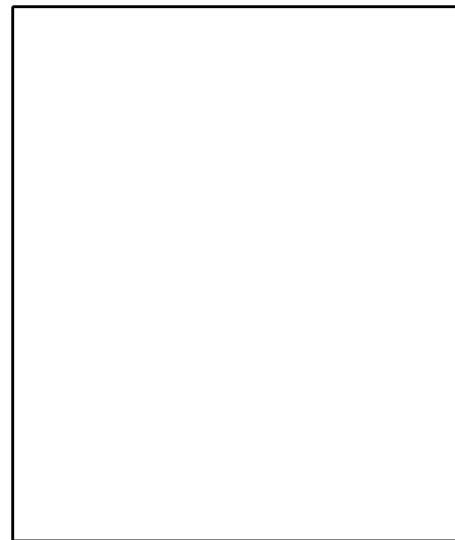

BACK

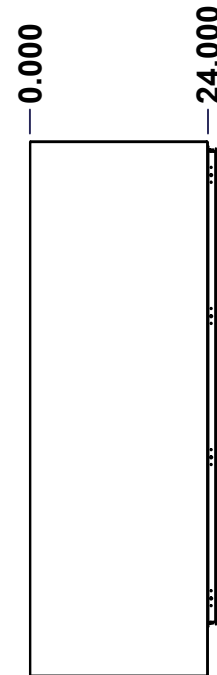

LEFT

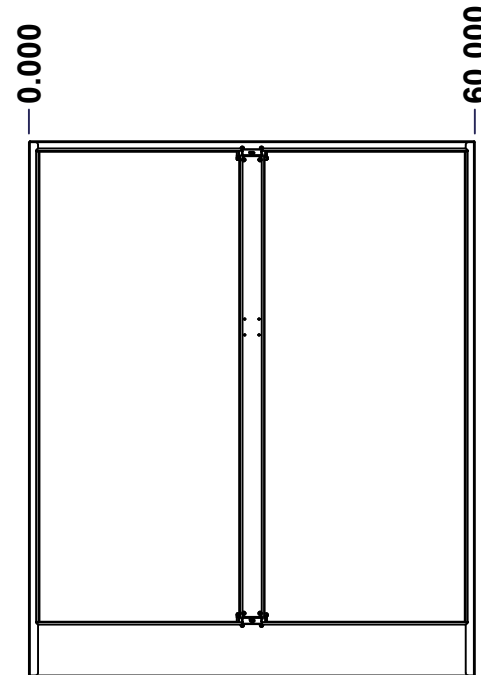

FRONT

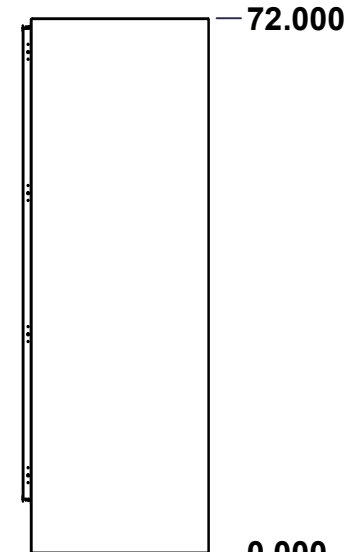

RIGHT

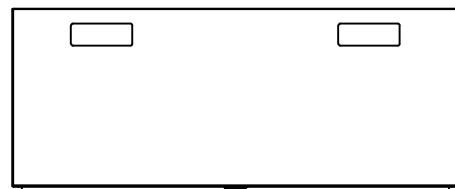

BOTTOM

No.	Revisions	Date	By/Par

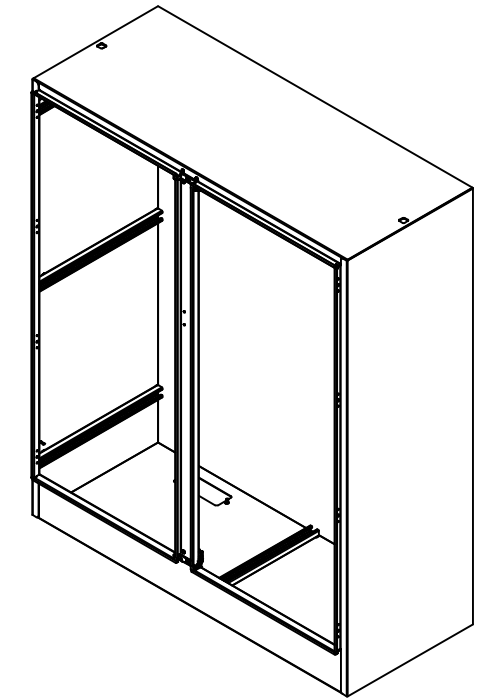

Isometric View



Tél: (450) 979-4373
 Fax: (450) 979-4626
www.exmweb.com

Flatness
Aplatissement

Max 3.0mm

Projection



Customer Client	Date
Drawn By Dessiné Par BoxCad: BoxCad	Date 10/10/2019
Material Matière 12 Ga Cold Rolled A1008 CS Type B (2.5mm)	

Color Couleur Asa-61 Grey	Finish Fini Smooth
------------------------------	-----------------------

Description 9412DD 72" x 60" x 24" Body	Detail Rev.
--	-------------

Part Number Numéro Pièce 9412DD726024B	Rev. 0	3
--	---------------	---

SEE BILL OF MATERIAL ON LAST PAGE

This drawing is confidential and must not be reproduced or used without the consent of EXM

Ce dessin est confidentiel et ne doit pas être reproduit ou utilisé sans le consentement de EXM

STANDARD FEATURES ARE NOT LISTED IN THIS HOLE TABLE

HOLE TABLE - TOP VIEW (CUSTOM FEATURE ONLY)

CUT-OUT	XDIM	YDIM	DESCRIPTION
1	44.911	19.911	Struts CR400 21.500" (Inside)
2	14.911	19.911	Struts CR400 21.500" (Inside)
3	44.911	20.840	STUDS M6 x 10mm (Inside)
4	55.777	19.911	STUDS M6 x 10mm (Inside)
5	14.911	20.840	STUDS M6 x 10mm (Inside)
6	25.777	19.911	STUDS M6 x 10mm (Inside)
7	28.982	7.536	STUDS M6 x 10mm (Inside)
8	28.982	16.286	STUDS M6 x 10mm (Inside)

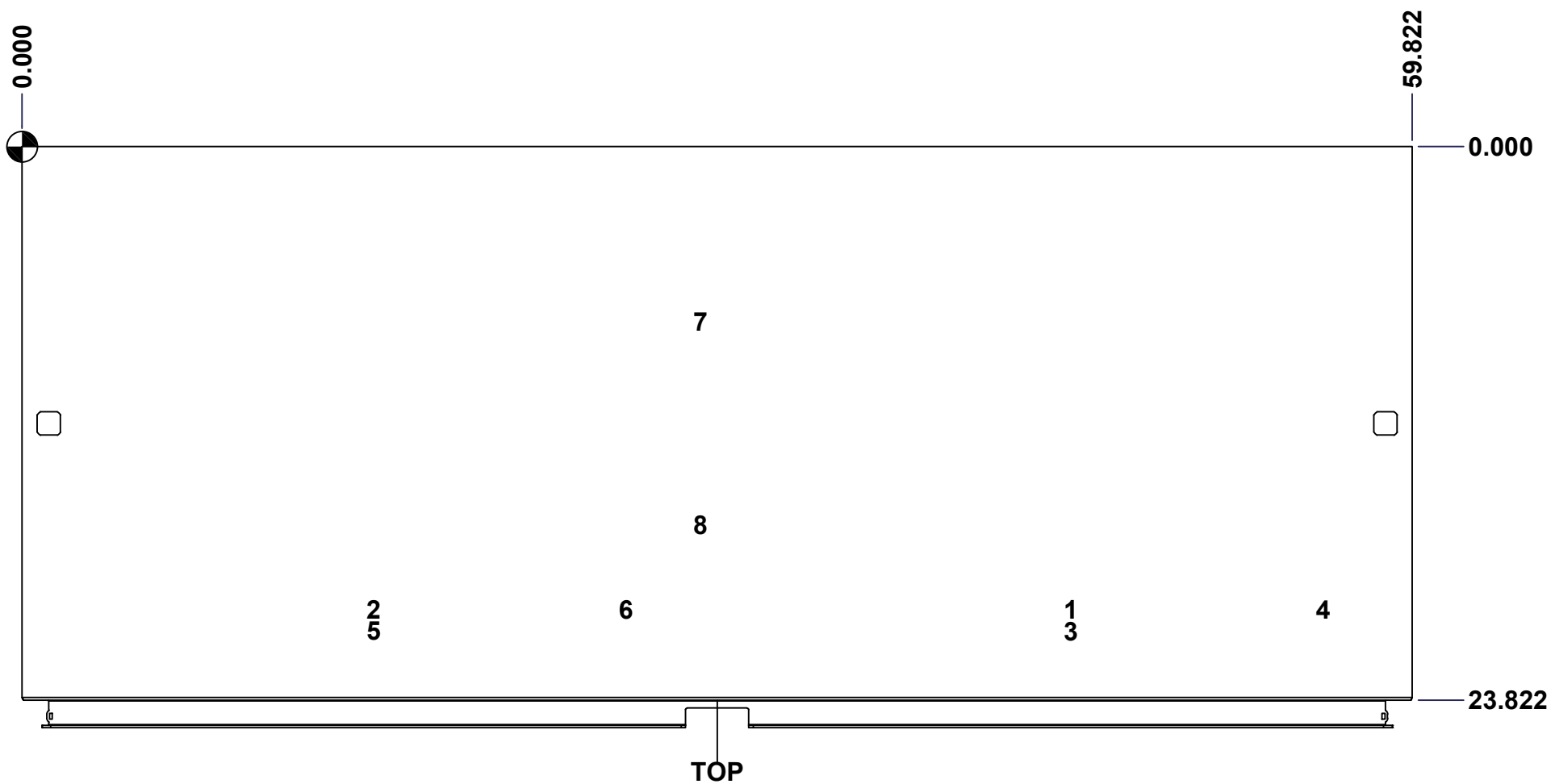

	Description 9412DD 72" x 60" x 24" Body	Status (NULL)
	Part Number Numéro Pièce 9412DD726024B	Rev. 4 0

This drawing is confidential and must not be reproduced or used without the consent of EXM

Ce dessin est confidentiel et ne doit pas être reproduit ou utilisé sans le consentement de EXM

STANDARD FEATURES ARE NOT LISTED IN THIS HOLE TABLE

HOLE TABLE - RIGHT VIEW (CUSTOM FEATURE ONLY)

CUT-OUT	XDIM	YDIM	DESCRIPTION
1	22.411	11.286	GND STUD M6 x 16mm (Inside)
2	7.536	66.107	STUDS M6 x 10mm (Inside)
3	16.286	66.107	STUDS M6 x 10mm (Inside)
4	7.536	7.857	STUDS M6 x 10mm (Inside)
5	16.286	7.857	STUDS M6 x 10mm (Inside)
6	7.536	36.982	STUDS M6 x 10mm (Inside)
7	16.286	36.982	STUDS M6 x 10mm (Inside)

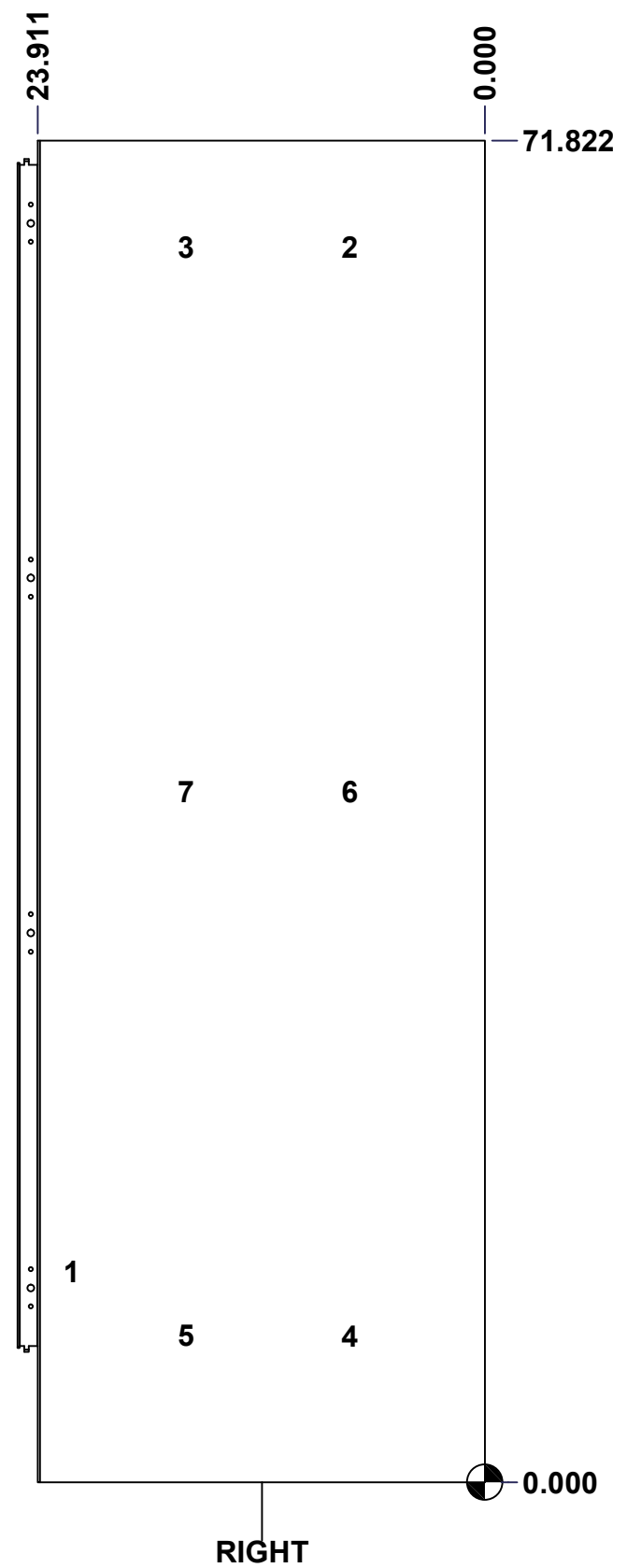

	Description	Status
	9412DD 72" x 60" x 24" Body	(NULL)
	Part Number Numéro Pièce	Rev.
	9412DD726024B	0 / 5
		16

This drawing is confidential and must not be reproduced or used without the consent of EXM

Ce dessin est confidentiel et ne doit pas être reproduit ou utilisé sans le consentement de EXM

STANDARD FEATURES ARE NOT LISTED IN THIS HOLE TABLE

HOLE TABLE - BOTTOM VIEW (CUSTOM FEATURE ONLY)

CUT-OUT	XDIM	YDIM	DESCRIPTION
1	7.286	3.411	GP STUD M6 x 16mm (Inside)
2	16.536	3.411	GP STUD M6 x 16mm (Inside)
3	43.286	3.411	GP STUD M6 x 16mm (Inside)
4	52.536	3.411	GP STUD M6 x 16mm (Inside)

5	28.982	7.536	STUDS M6 x 10mm (Inside)
6	28.982	16.286	STUDS M6 x 10mm (Inside)

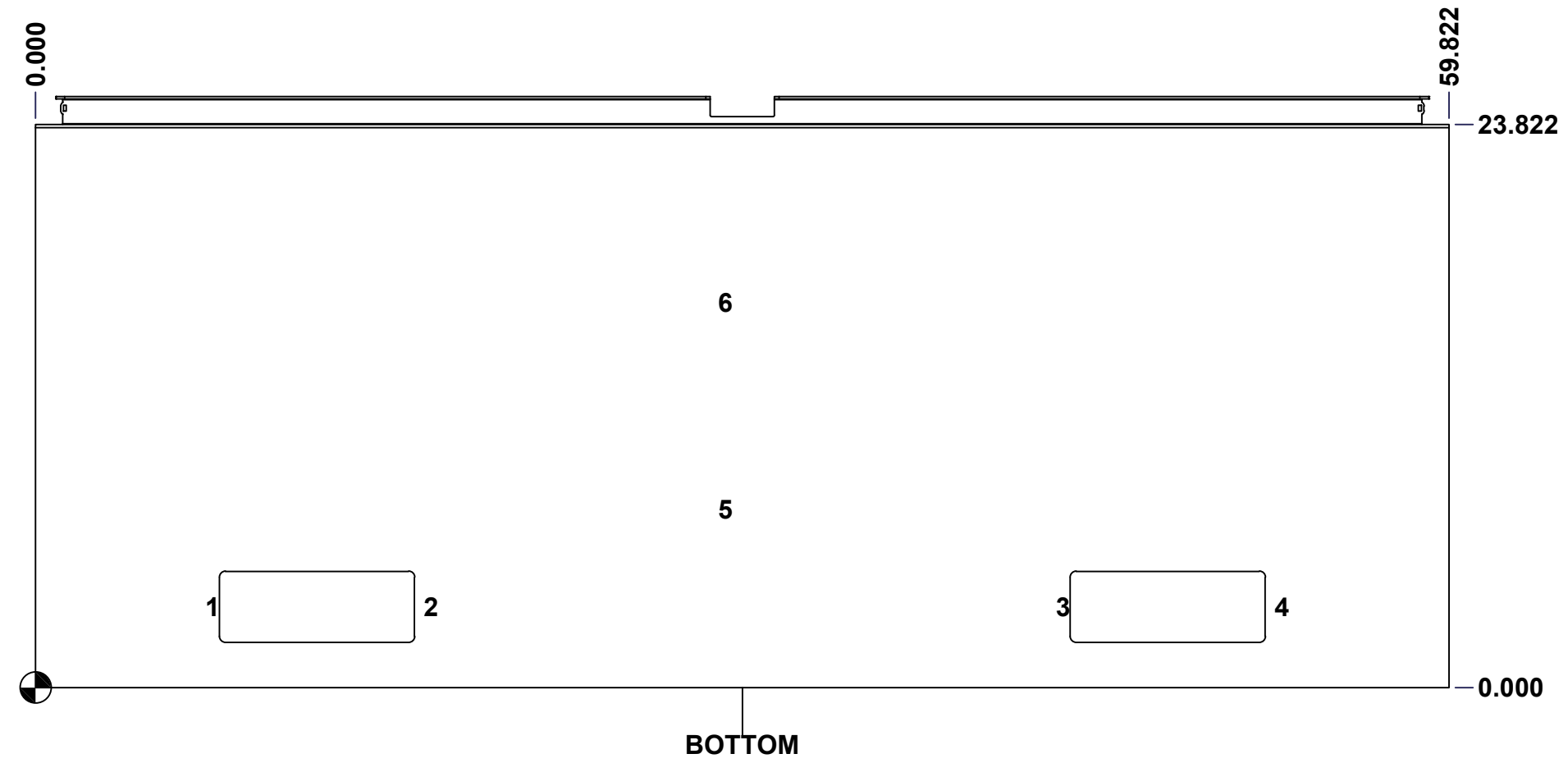

	Description 9412DD 72" x 60" x 24" Body	Status (NULL)
	Part Number Numéro Pièce 9412DD726024B	Rev. 6 0

This drawing is confidential and must not be reproduced or used without the consent of EXM

Ce dessin est confidentiel et ne doit pas être reproduit ou utilisé sans le consentement de EXM

STANDARD FEATURES ARE NOT LISTED IN THIS HOLE TABLE

HOLE TABLE - LEFT VIEW (CUSTOM FEATURE ONLY)

CUT-OUT	XDIM	YDIM	DESCRIPTION
1	22.411	11.286	GND STUD M6 x 16mm (Inside)
2	7.536	66.107	STUDS M6 x 10mm (Inside)
3	16.286	66.107	STUDS M6 x 10mm (Inside)
4	7.536	7.857	STUDS M6 x 10mm (Inside)
5	16.286	7.857	STUDS M6 x 10mm (Inside)
6	7.536	36.982	STUDS M6 x 10mm (Inside)
7	16.286	36.982	STUDS M6 x 10mm (Inside)

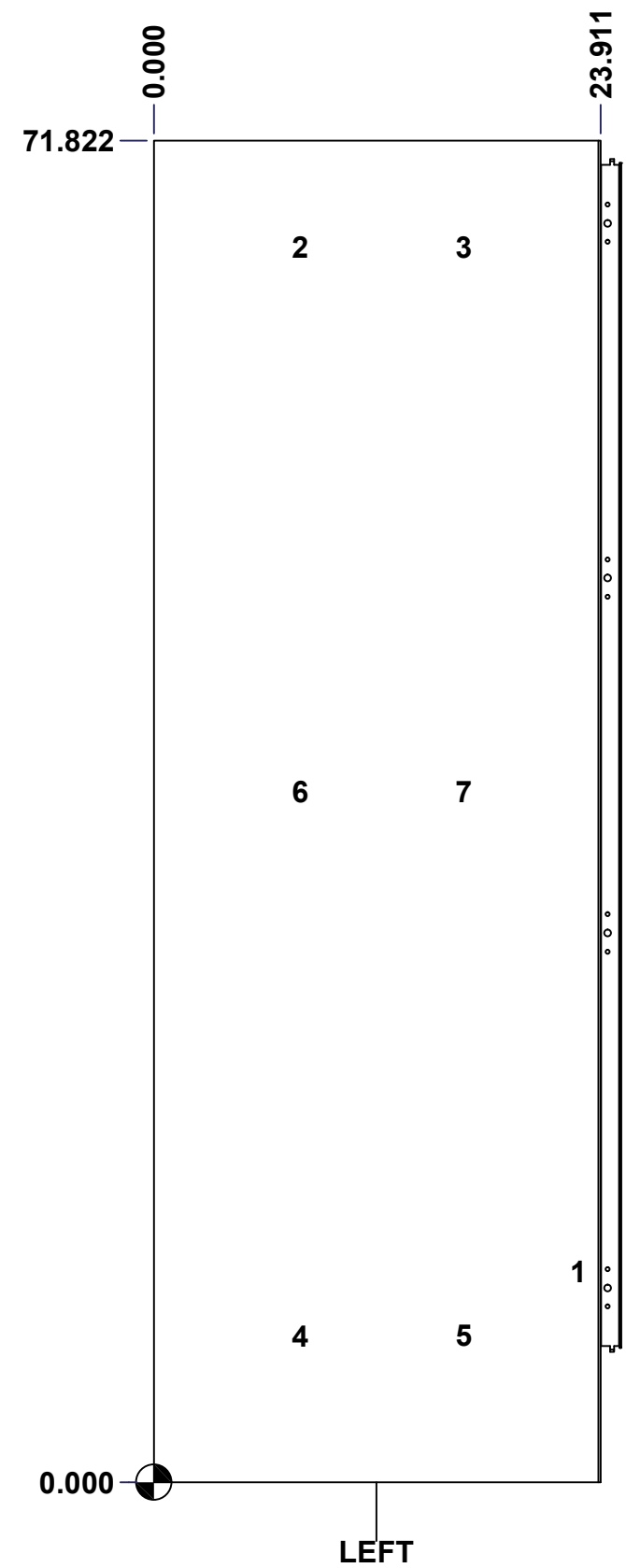

	Description	Status
	9412DD 72" x 60" x 24" Body	(NULL)
Part Number Numéro Pièce 9412DD726024B	Rev.	7
	0	16

This drawing is confidential and must not be reproduced or used without the consent of EXM

Ce dessin est confidentiel et ne doit pas être reproduit ou utilisé sans le consentement de EXM

STANDARD FEATURES ARE NOT LISTED IN THIS HOLE TABLE

HOLE TABLE - CENTER VIEW (CUSTOM FEATURE ONLY)

CUT-OUT	XDIM	YDIM	DESCRIPTION
1	0.748	38.210	PEM FH-M6-15ZI (Inside)
2	0.748	40.336	PEM FH-M6-15ZI (Inside)
3	2.717	38.210	PEM FH-M6-15ZI (Inside)
4	2.717	40.336	PEM FH-M6-15ZI (Inside)

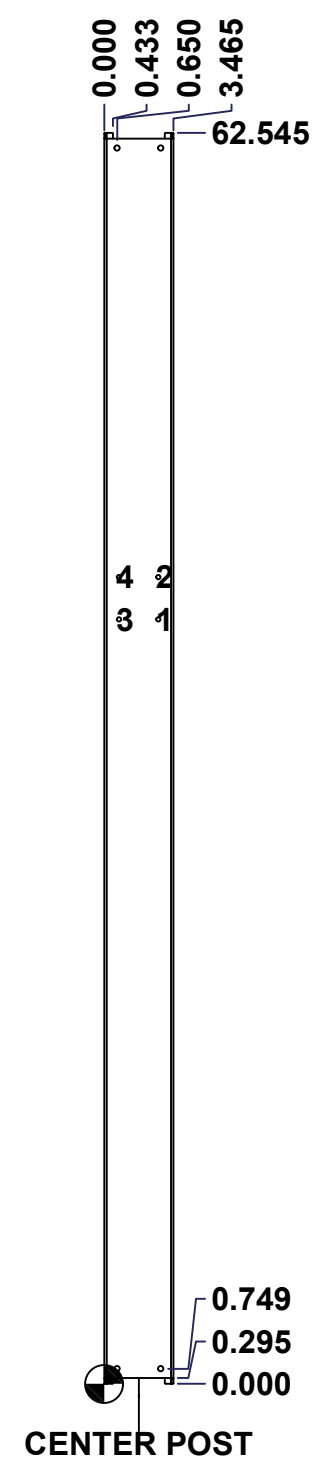

	Description	Status	
	9412DD 72" x 60" x 24" Body	(NULL)	
	Part Number Numéro Pièce	Rev.	8
	9412DD726024B	0	16

This drawing is confidential and must not be reproduced or used without the consent of EXM

Ce dessin est confidentiel et ne doit pas être reproduit ou utilisé sans le consentement de EXM

No.	Revisions	Date	By/Par

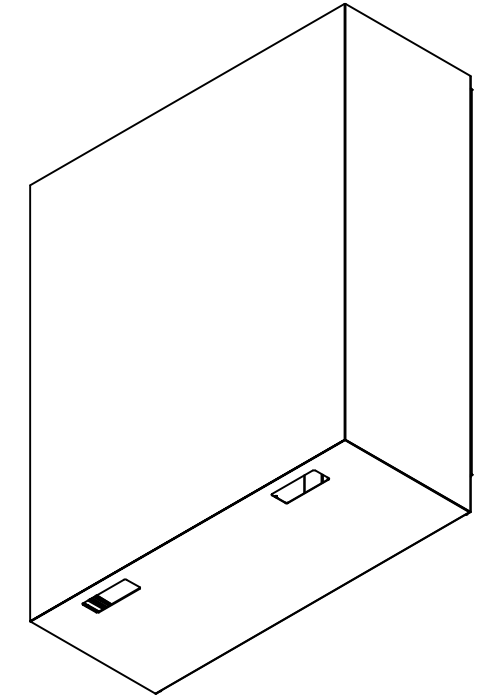

Isometric View



20	STK-Q-16030	0	Stud M6 x 10mm Steel
4	STK-PEM-FH-M6-15ZI	0	PEM Self-Clinching Stud M6 x 15.0mm
2	STK-Q-74910	0	Eyebolt Lifting Angle (15.500")
1	STK-P-02400S	0	Powder Paint (Asa-61 Grey / Smooth)
1	STK-Q-52200-24	2	Sasco Strut S5 (21.500" Long)
7	STK-Q-52250-24	2	Sasco Strut S5 (23.500" Long)
1	STK-A-75454	3	Center Post - Sealing Block with Latch Assembly (Large)
1	9412DD726024CP-P	0	9412DD 72" Center Post Part
1	9412DD726024BT-P	0	9412DD 60" x 24" Bottom Part
1	9412DD726024T-P	0	9412DD 60" x 24" Top Part
1	9412DD726024RS-P	0	9412DD 72" x 60" Right Part
1	9412DD726024LS-P	0	9412DD 72" x 60" Left Part
1	9412DD726024B-P	0	9412DD 72" x 60" Back Part
2	9412DD726024_CR400M S_21.5	0	Commercial Roll Mild Steel (21.5in long)
6	STK-Q-16080	0	Ground Stud M6 x 16mm Steel

Qty	Part Number	Rev	Description
Parts List			

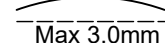
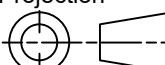
 Tél: (450) 979-4373 Fax: (450) 979-4626 www.exmweb.com	Flatness Aplatissement	 Max 3.0mm	
	Projection		
Customer Client	Date	Date 10/10/2019	
Drawn By Dessiné Par	BoxCad: BoxCad	Date 10/10/2019	
Material Matière	12 Ga Cold Rolled A1008 CS Type B (2.5mm)		
Color Couleur	Asa-61 Grey	Finish Fini	Smooth
Description	9412DD 72" x 60" x 24" Body		Detail Rev.
Part Number Numéro Pièce	9412DD726024B		Rev. 9 0

This drawing is confidential and must not be reproduced or used without the consent of EXM

Ce dessin est confidentiel et ne doit pas être reproduit ou utilisé sans le consentement de EXM

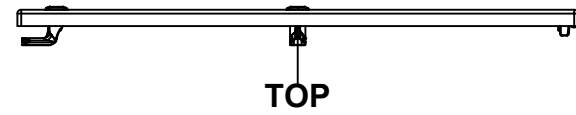

TOP

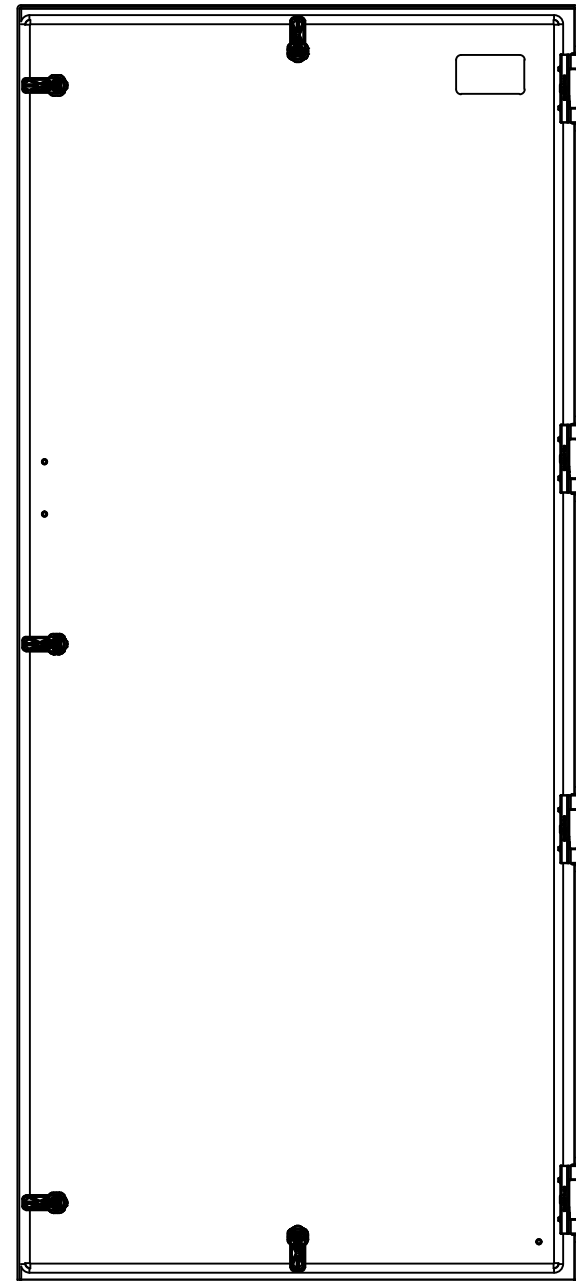

BACK



BOTTOM

0.000
0.835



LEFT

0.000

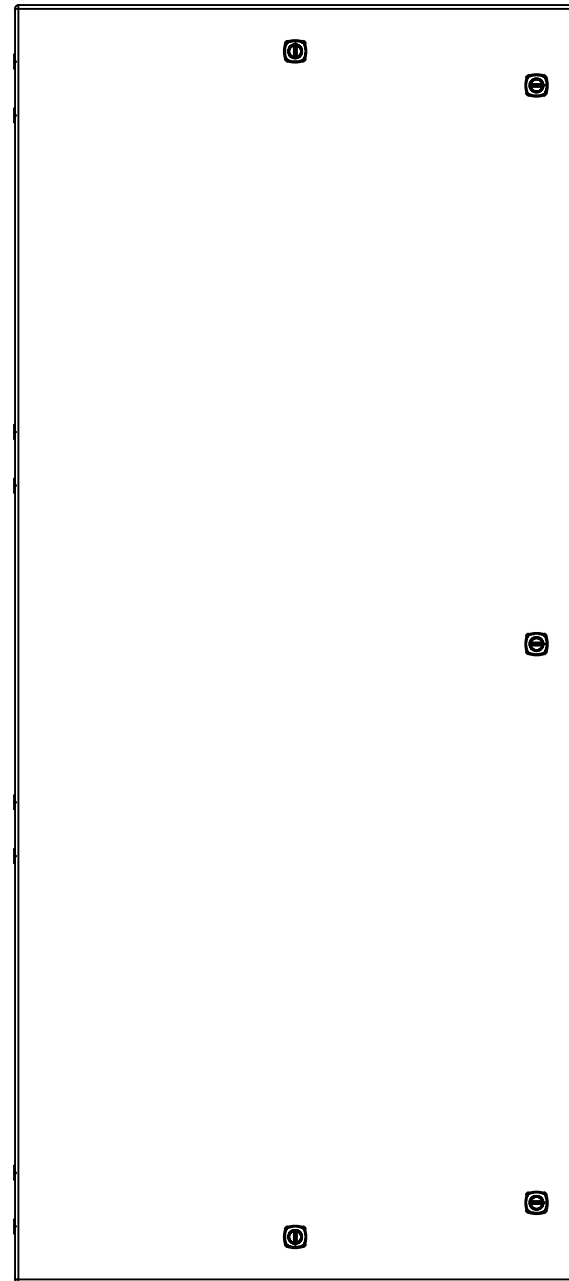

FRONT

28.750

65.549

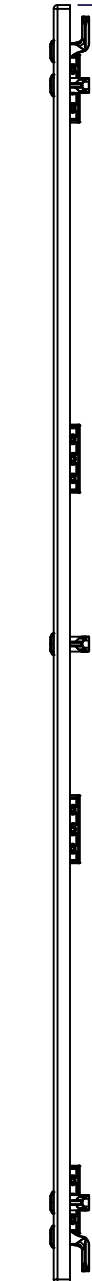

RIGHT

0.000

No.	Revisions	Date	By/Par

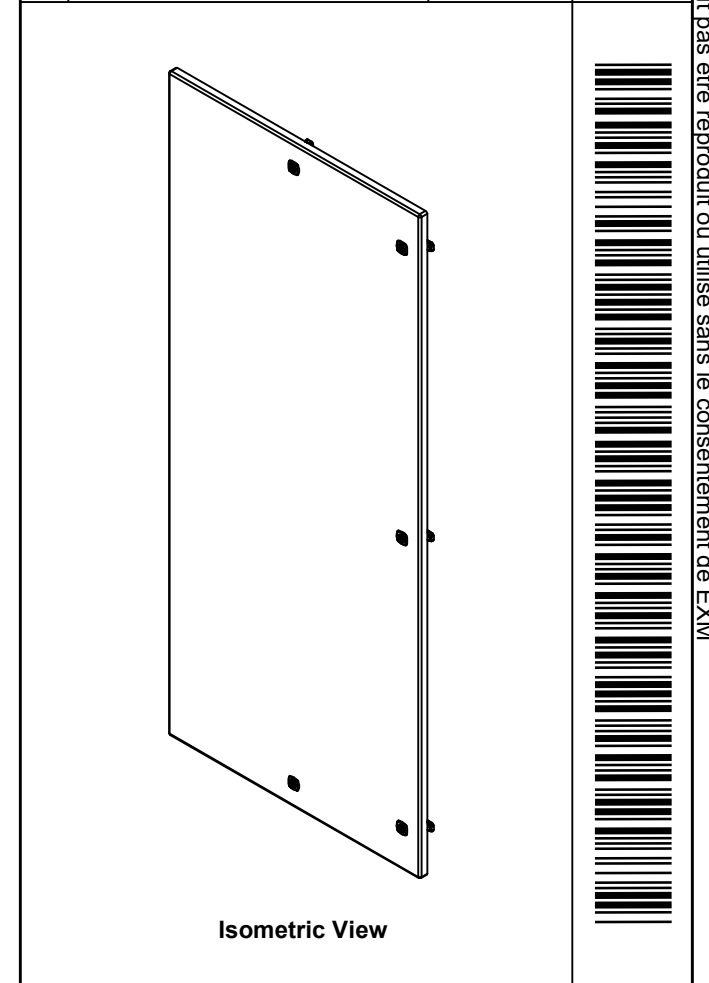

Isometric View

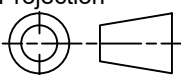

 Tél: (450) 979-4373 Fax: (450) 979-4626 www.exmweb.com		Flatness Aplatissement Max 3.0mm Projection 
Customer Client		Date
Drawn By / Dessiné Par	BoxCad: BoxCad	Date
Material / Matière	12 Ga Cold Rolled A1008 CS Type B (2.5mm)	
Color / Couleur	Asa-61 Grey	Finish / Fini: Smooth
Description		Detail Rev.
9412DD 72" x 60" Lock Door		
Part Number / Numéro Pièce	Rev.	
9412DD726024LD	0	10 / 16

SEE BILL OF MATERIAL ON LAST PAGE

This drawing is confidential and must not be reproduced or used without the consent of EXM

Ce dessin est confidentiel et ne doit pas être reproduit ou utilisé sans le consentement de EXM

STANDARD FEATURES ARE NOT LISTED IN THIS HOLE TABLE

HOLE TABLE - FRONT VIEW (CUSTOM FEATURE ONLY)

CUT-OUT	XDIM	YDIM	DESCRIPTION
1	26.750	4.118	LOCK 889 SCQ4-SL @ 0.0°
2	14.375	63.180	LOCK 889 SCQ4-SL @ 90.0°
3	14.375	2.368	LOCK 889 SCQ4-SL @ 270.0°
4	26.750	61.430	LOCK 889 SCQ4-SL @ 0.0°
5	26.750	32.774	LOCK 889 SCQ4-SL @ 0.0°
6	2.000	2.118	GND STUD M6 x 16mm (Inside)
7	27.372	39.435	STUDS M6 x 18mm (Inside)
8	27.372	42.113	STUDS M6 x 18mm (Inside)

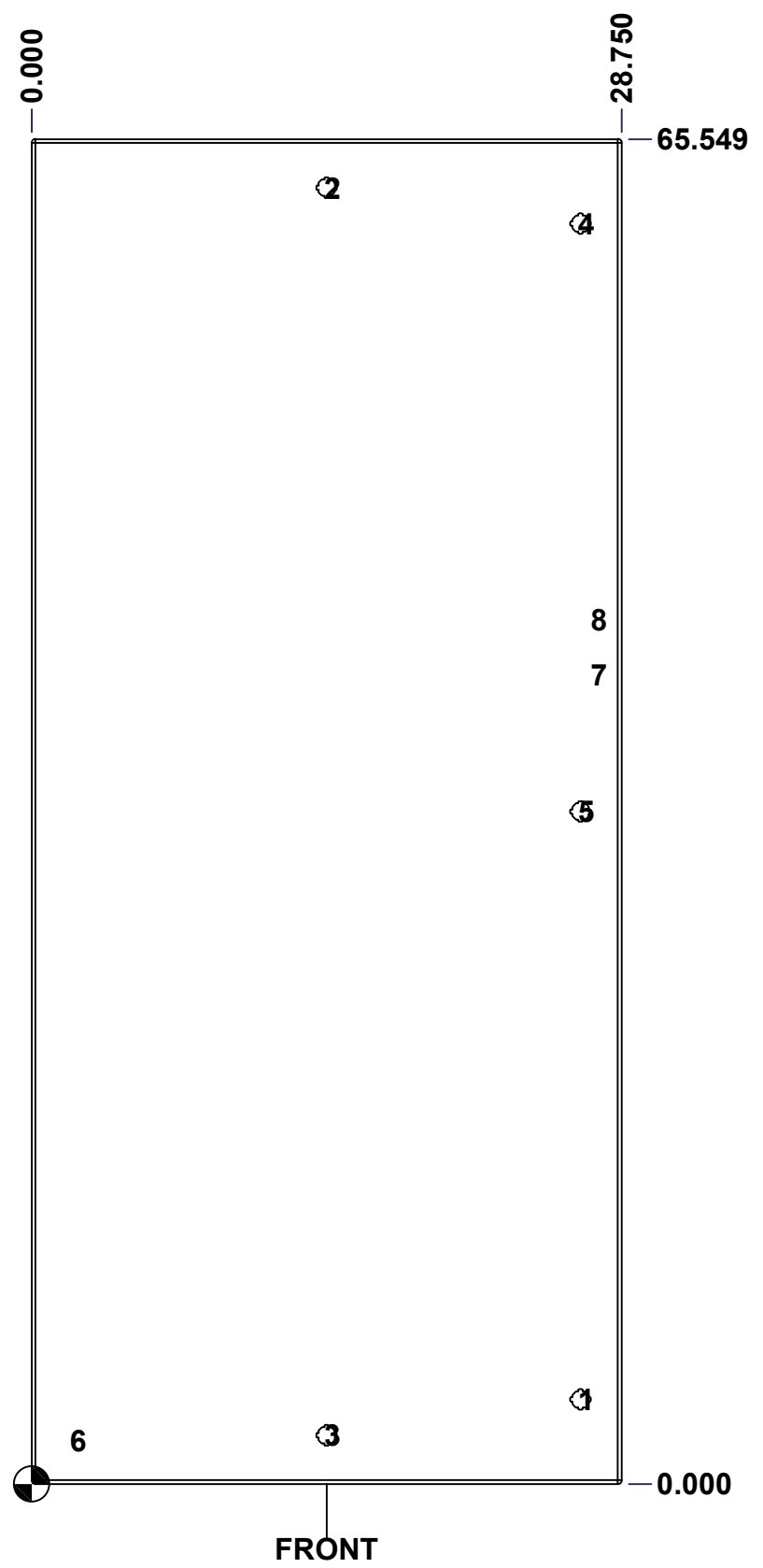

	Description	Status
	9412DD 72" x 60" Lock Door	(NULL)
	Part Number Numéro Pièce	Rev.
	9412DD726024LD	0
		11
		16

This drawing is confidential and must not be reproduced or used without the consent of EXM

Ce dessin est confidentiel et ne doit pas être reproduit ou utilisé sans le consentement de EXM

No.	Revisions	Date	By/Par

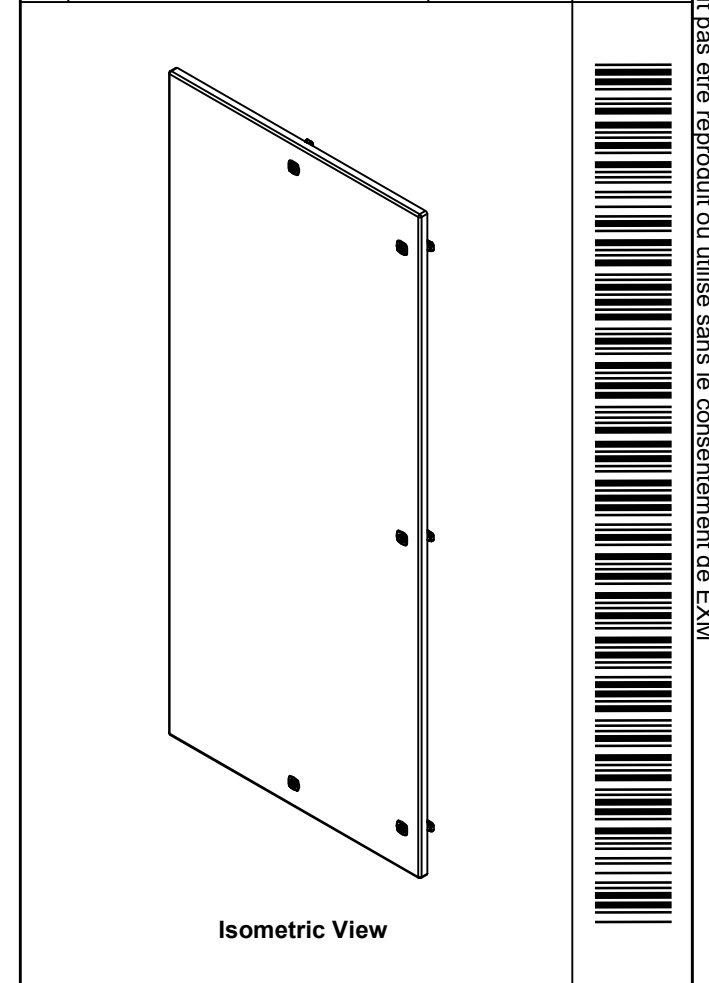

EXM
www.exmweb.com

Tél: (450) 979-4373
Fax: (450) 979-4626

Flatness
Aplatissement
Max 3.0mm

Projection

Customer Client _____ Date _____

Drawn By Dessiné Par BoxCad: BoxCad Date 10/10/2019

Material Matière 12 Ga Cold Rolled A1008 CS Type B (2.5mm)

Color Couleur Asa-61 Grey Finish Fini Smooth

Description 9412DD 72" x 60" Lock Door Detail Rev. _____

Part Number Numéro Pièce **9412DD726024LD** Rev. **0** 12/16

QTY	Part Number	Rev	Description
2	STK-Q-16050	1	Stud M6 x 18mm Steel
1	STK-Q-16080	0	Ground Stud M6 x 16mm Steel
1	STK-P-02400S	0	Powder Paint (Asa-61 Grey / Smooth)
1	STK-S-00100	0	3.5" x 2" Silver Milar Flexcon Sticker
1	9412DD726024DG	0	9412DD 72" x 60" Door Gasket
1	9412DD726024LD-P	0	9412DD 72" x 60" Slave Door Part
4	STK-K-09860	7	Cabinet Hinge with Captive Pins
5	STK-K-12580	0	9412 1/4 Turn Lock
Parts List			

This drawing is confidential and must not be reproduced or used without the consent of EXM

Ce dessin est confidentiel et ne doit pas être reproduit ou utilisé sans le consentement de EXM

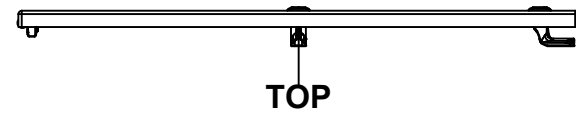

TOP

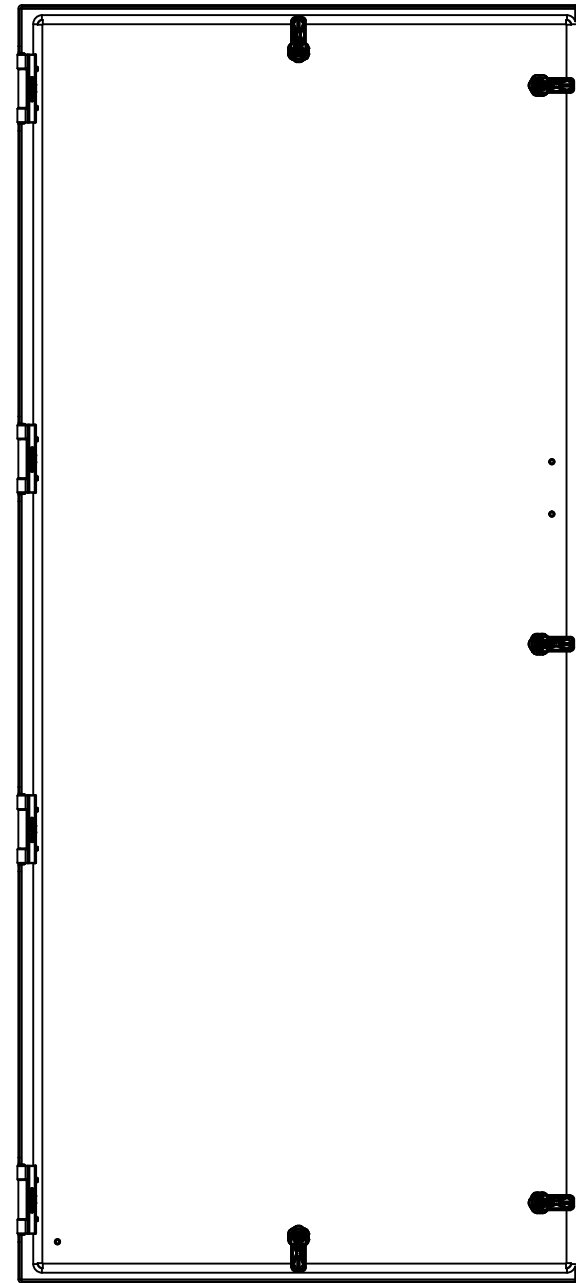

BACK



BOTTOM

0.000
0.835



LEFT

28.750

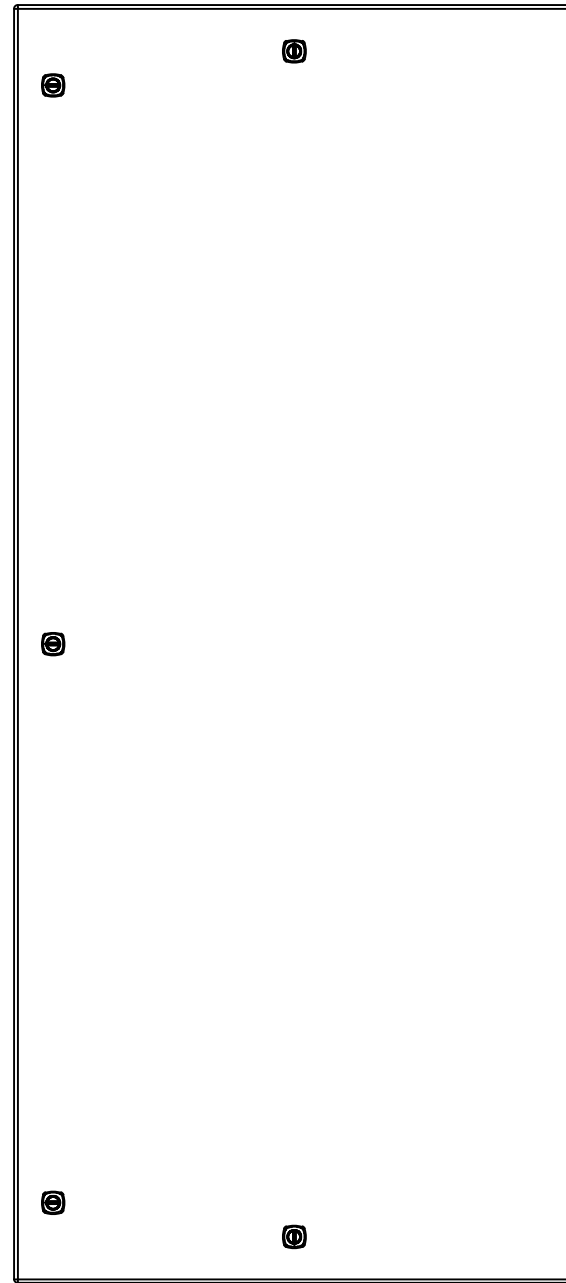

FRONT

0.000

65.549



RIGHT

0.000

No.	Revisions	Date	By/Par

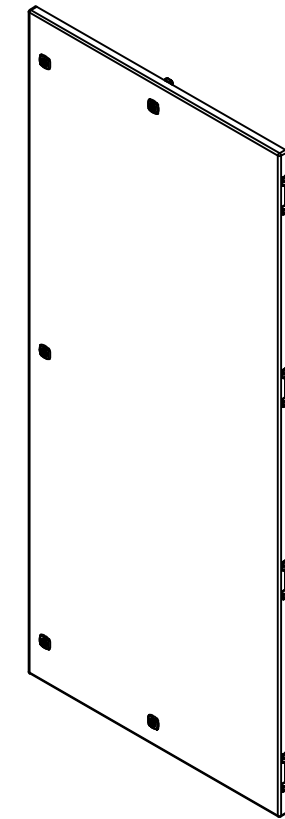

Isometric View



Tél: (450) 979-4373
Fax: (450) 979-4626
www.exmweb.com

Flatness
Aplatissement

Max 3.0mm

Projection

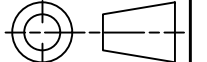

Customer Client	Date
Drawn By / Dessiné Par: BoxCad: BoxCad	Date: 10/10/2019
Material / Matière: 12 Ga Cold Rolled A1008 CS Type B (2.5mm)	
Color / Couleur: Asa-61 Grey	Finish / Fini: Smooth

Description: 9412DD 72" x 60" Flange Door	Detail Rev.
---	-------------

Part Number / Numéro Pièce: 9412DD726024FD	Rev. 0	13
--	--------	----

SEE BILL OF MATERIAL ON LAST PAGE

This drawing is confidential and must not be reproduced or used without the consent of EXM

Ce dessin est confidentiel et ne doit pas être reproduit ou utilisé sans le consentement de EXM

STANDARD FEATURES ARE NOT LISTED IN THIS HOLE TABLE

HOLE TABLE - FRONT VIEW (CUSTOM FEATURE ONLY)

CUT-OUT	XDIM	YDIM	DESCRIPTION
1	26.750	4.118	LOCK 889 SCQ4-SL @ 180.0°
2	26.750	61.430	LOCK 889 SCQ4-SL @ 180.0°
3	26.750	32.774	LOCK 889 SCQ4-SL @ 180.0°
4	14.375	63.180	LOCK 889 SCQ4-SL @ 90.0°
5	14.375	2.368	LOCK 889 SCQ4-SL @ 270.0°
6	2.000	2.118	GND STUD M6 x 16mm (Inside)
7	27.372	39.435	STUDS M6 x 18mm (Inside)
8	27.372	42.113	STUDS M6 x 18mm (Inside)

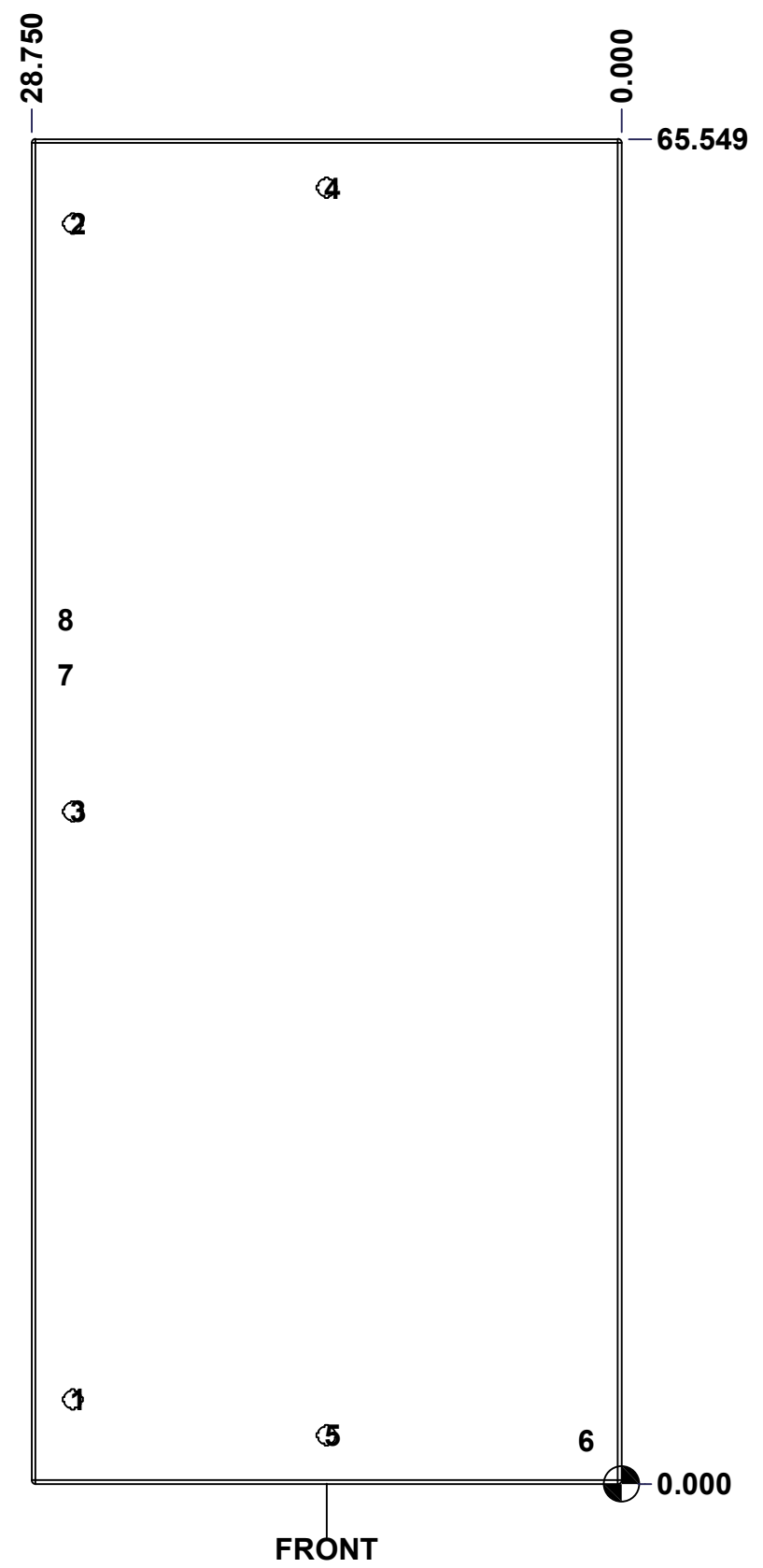

	Description	Status
	9412DD 72" x 60" Flange Door	(NULL)
	Part Number Numéro Pièce	Rev.
	9412DD726024FD	0 / 14
		16

This drawing is confidential and must not be reproduced or used without the consent of EXM

Ce dessin est confidentiel et ne doit pas être reproduit ou utilisé sans le consentement de EXM

No.	Revisions	Date	By/Par

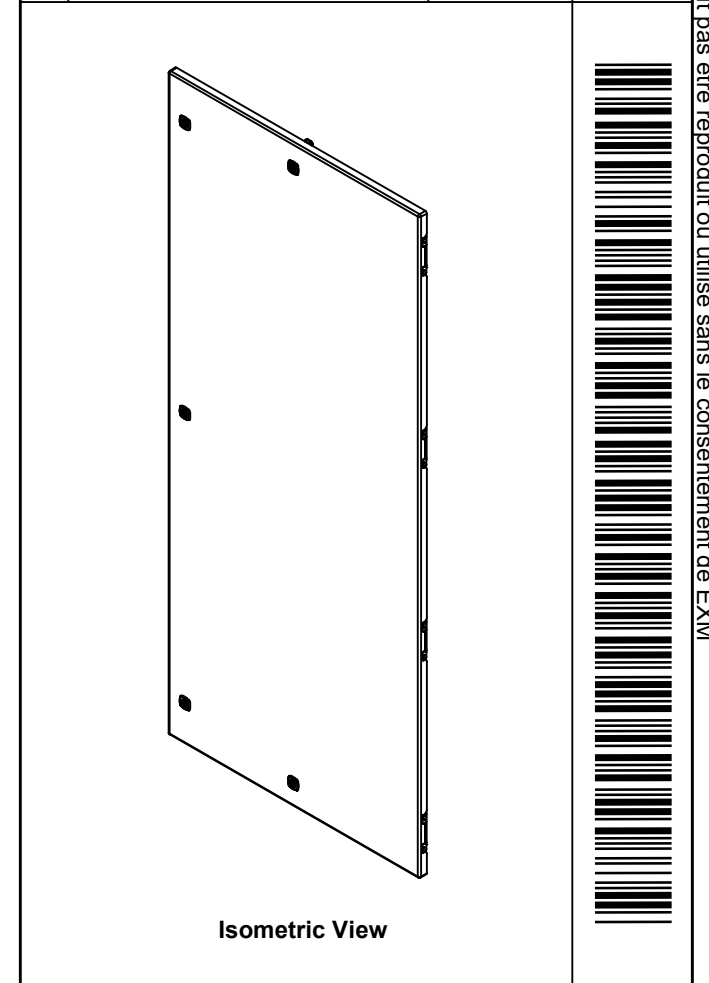

Tél: (450) 979-4373 Fax: (450) 979-4626 www.exmweb.com		Flatness Aplatissement
		Max 3.0mm
Customer Client		Date
Drawn By Dessiné Par		Date
Material Matière		Projection
Color Couleur		Finish Fini
Description		Detail Rev.
Part Number Numéro Pièce		Rev.

QTY	Part Number	Rev	Description
2	STK-Q-16050	1	Stud M6 x 18mm Steel
1	STK-Q-16080	0	Ground Stud M6 x 16mm Steel
1	STK-P-02400S	0	Powder Paint (Asa-61 Grey / Smooth)
1	9412DD726024DG	0	9412DD 72" x 60" Door Gasket
1	9412DD726024FD-P	0	9412DD 72" x 60" Master Door Part
4	STK-K-09860	7	Cabinet Hinge with Captive Pins
5	STK-K-12580	0	9412 1/4 Turn Lock
Parts List			

All knockouts are actual size / Les disques défonçables sont grandeur réel
 All dimensions are before paint / Toutes les dimensions sont avant peinture

This drawing is confidential and must not be reproduced or used without the consent of EXM

Ce dessin est confidentiel et ne doit pas être reproduit ou utilisé sans le consentement de EXM

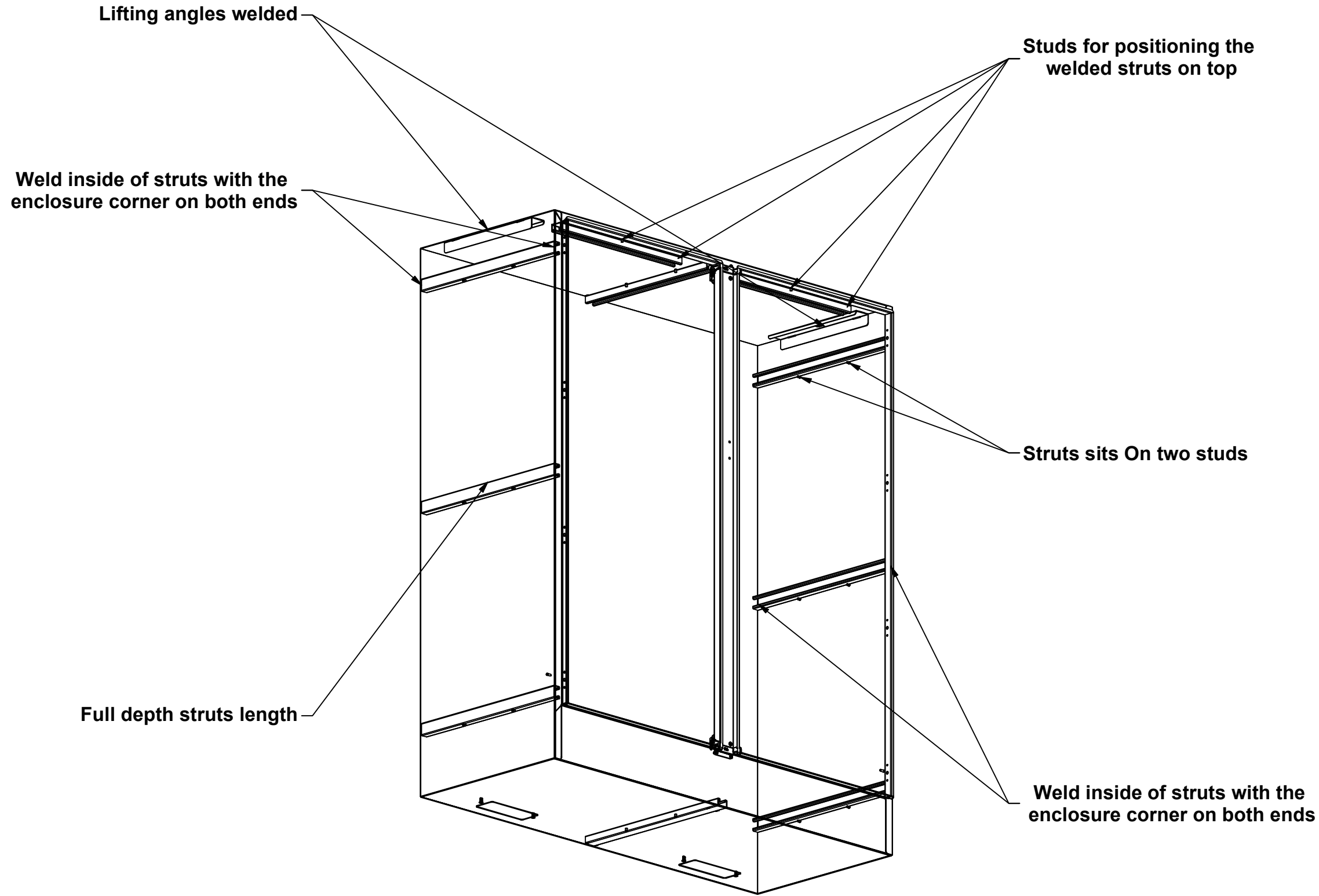

No.	Revisions	Date	By/Par

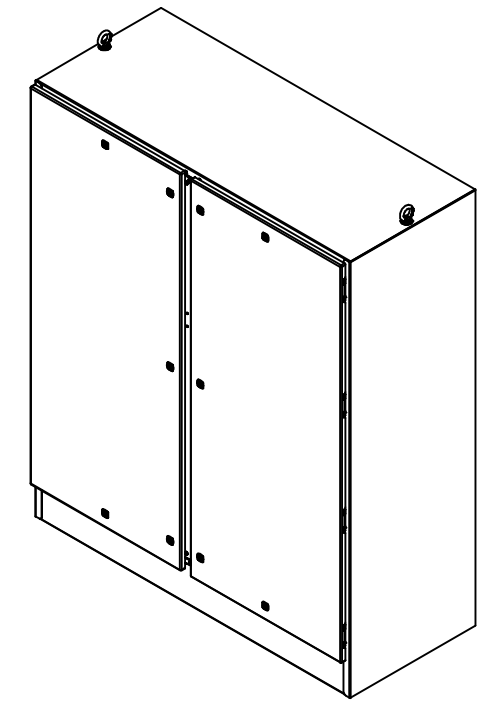

Isometric View

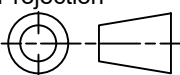

 Tél: (450) 979-4373 Fax: (450) 979-4626 www.exmweb.com	Flatness Aplatissement
	Max 3.0mm
	Projection
	
Customer Client	Date
Drawn By Dessiné Par BoxCad	Date 8/11/2005
Material Matière 12 Ga Cold Rolled A1008 CS Type B (2.5mm)	
Color Couleur Asa-61 Grey	Finish Fini Smooth
Description 9412DD 72" x 60" x 24" Assembly	Detail Rev.
Part Number Numéro Pièce 9412DD Welding Details	Rev. 16 0