

This drawing is confidential and must not be reproduced or used without the consent of EXM

Ce dessin est confidentiel et ne doit pas être reproduit ou utilisé sans le consentement de EXM

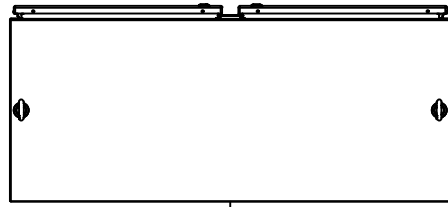

TOP

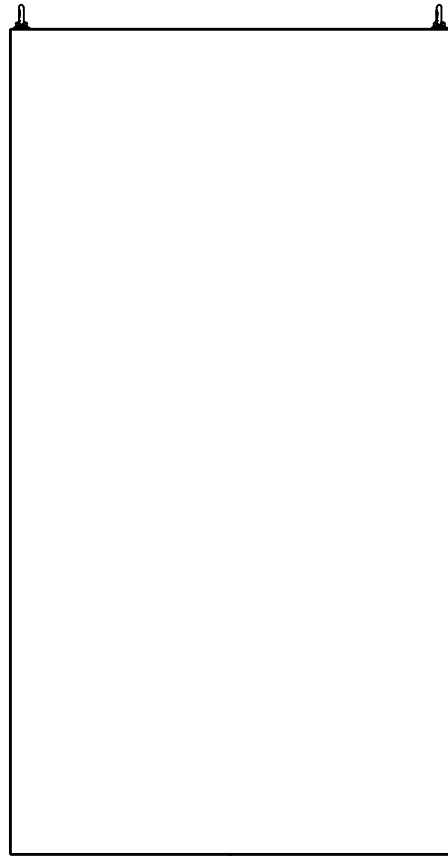

BACK

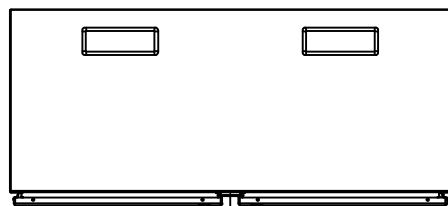

BOTTOM

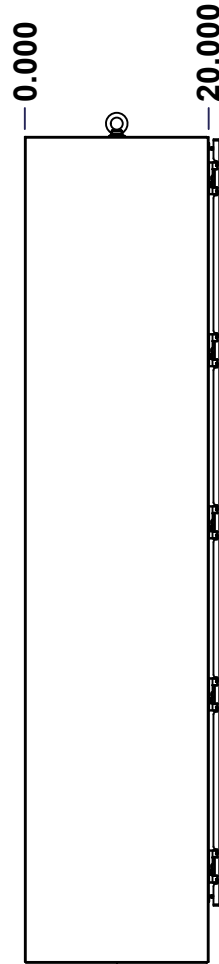

LEFT

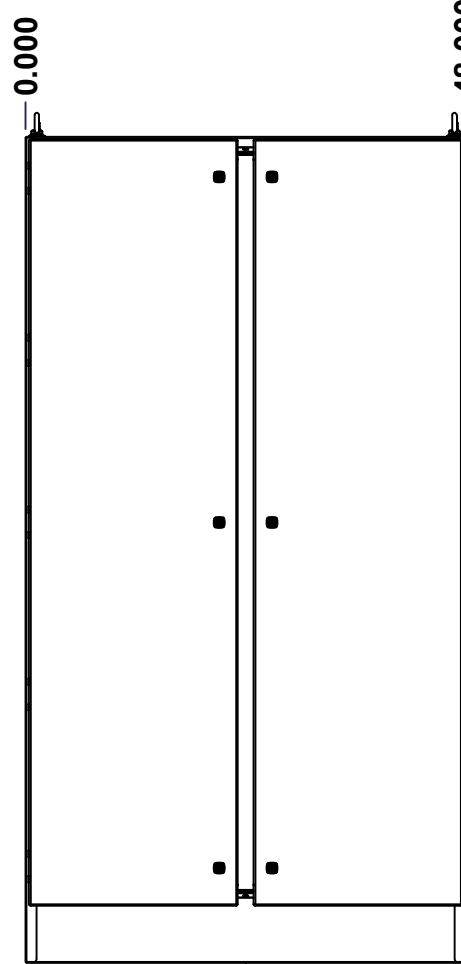

FRONT

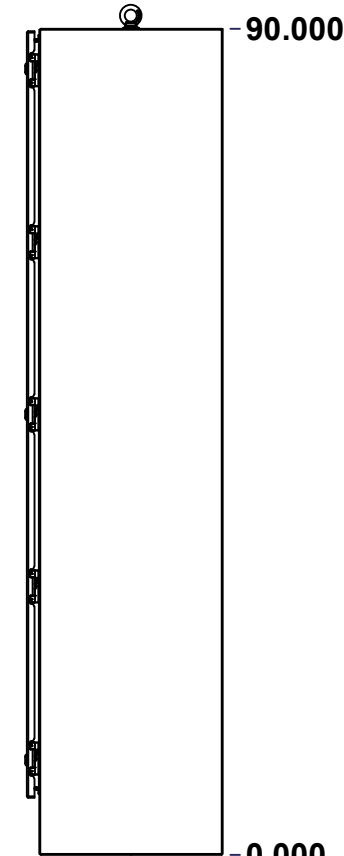

RIGHT

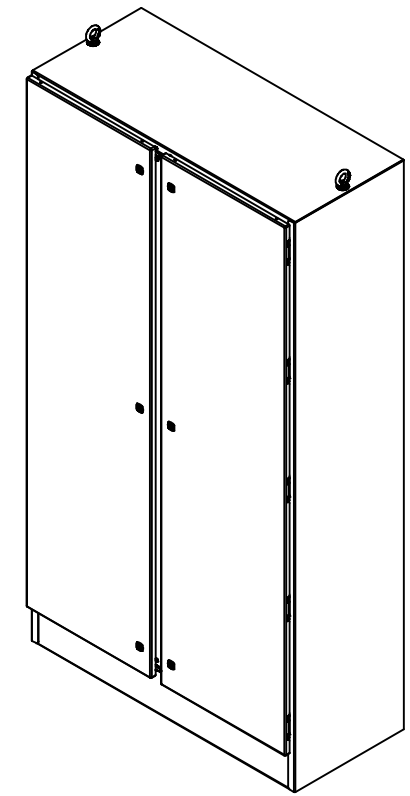

Isometric View

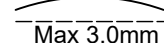
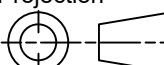

No.	Revisions	Date	By/Par

 Tél: (450) 979-4373 Fax: (450) 979-4626 www.exmweb.com		Flatness Aplatissement  Max 3.0mm Projection 
Customer Client	Date	
Drawn By Dessiné Par	BoxCad: BoxCad	Date 10-Oct-19
Material Matière	12 Ga Cold Rolled A1008 CS Type B (2.5mm)	
Color Couleur	Asa-61 Grey	Finish Fini Smooth
Description	Detail Rev.	
9412DD 90" x 48" x 20" Assembly		
Part Number Numéro Pièce	Rev.	1
9412DD904820	0	16

SEE BILL OF MATERIAL ON LAST PAGE

This drawing is confidential and must not be reproduced or used without the consent of EXM

Ce dessin est confidentiel et ne doit pas être reproduit ou utilisé sans le consentement de EXM

NOTE	
ITEM	DESCRIPTION
1	NEMA 4, 12 Enclosure (IP66)
2	C/W Standard ground studs on box and cover
3	W/O Standard door stiffener
4	W/O Inner panel
5	C/W Standard inner panel mounting struts
6	C/W Eyebolts sold separately (Installed by EXM)
7	C/W Struts installed (Included)
8	C/W Interlock Kit (Installed by EXM)

No.	Revisions	Date	By/Par

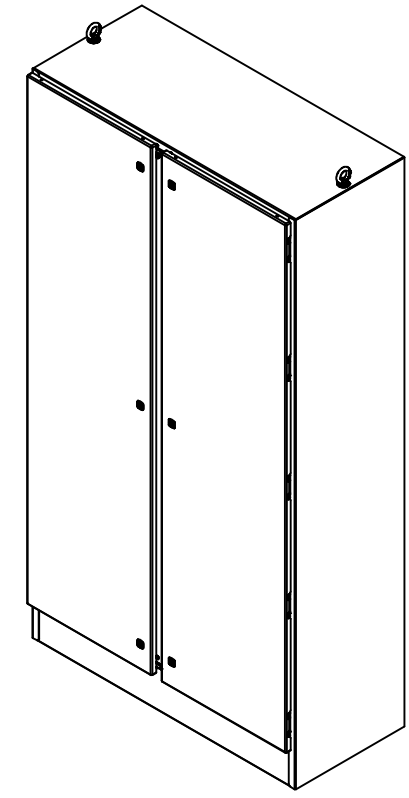

Isometric View

PACKING		
ITEM	QTY	DESCRIPTION
Cardboard sleeve	2	Top and Bottom
Cardboard strip	2	Between back of enclosure and inner panel
Plastic bag	1	To protect cover surface and inside gasket
Cardboard corner	4	To reinforced for the plastic strap tightening
Plastic strap - Black	2	To Squeeze 2 cardboard sleeve together
Packaging label	3	White label with PN
Plastic strap- Green	2	To secure the enclosure to the wood pallet
Wood Pallet	1	2" deeper and 3" larger than enclosure size

1	880INTI	4	880 INTI - Interlock Post Kit
1	880EB14	2	Eye Bolt M14 (Pack of 2)
1	889BPS	0	Inner Panel Strut Mounting Kit
1	9412DD904820FD	0	9412DD 90" x 48" Flange Door
1	9412DD904820LD	0	9412DD 90" x 48" Lock Door
1	9412DD904820B	0	9412DD 90" x 48" x 20" Body
2	9412DD904820GP	0	9412DD Gland Plate
10	STK-Q-04050-10	8	M6 x 10mm Hexagon Socket Head Machine Screw with Nyseal
Qty	Part Number	Rev	Description
Parts List			

	Tél: (450) 979-4373 Fax: (450) 979-4626 www.exmweb.com	Flatness Aplatissement Max 3.0mm
	Projection 	Customer Client Date
Drawn By Dessiné Par BoxCad: BoxCad	Date 10-Oct-19	Material Matière 12 Ga Cold Rolled A1008 CS Type B (2.5mm)
Color Couleur Asa-61 Grey	Finish Fini Smooth	Description 9412DD 90" x 48" x 20" Assembly
Part Number Numéro Pièce 9412DD904820	Rev. 0	Detail Rev. 2 16

This drawing is confidential and must not be reproduced or used without the consent of EXM

Ce dessin est confidentiel et ne doit pas être reproduit ou utilisé sans le consentement de EXM

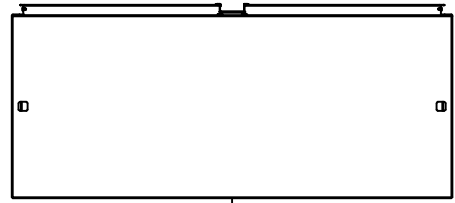

TOP

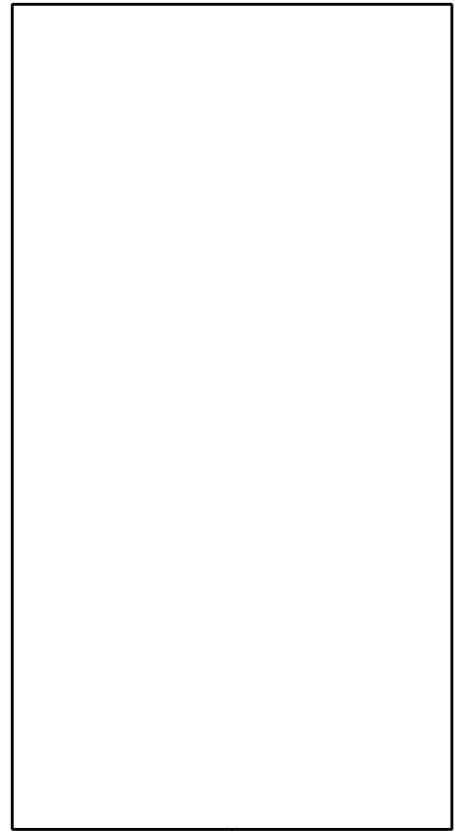

BACK

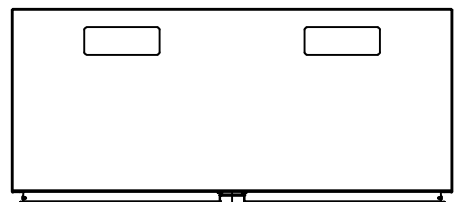

BOTTOM

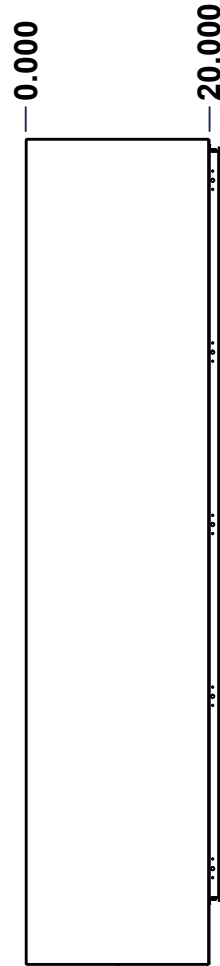

LEFT

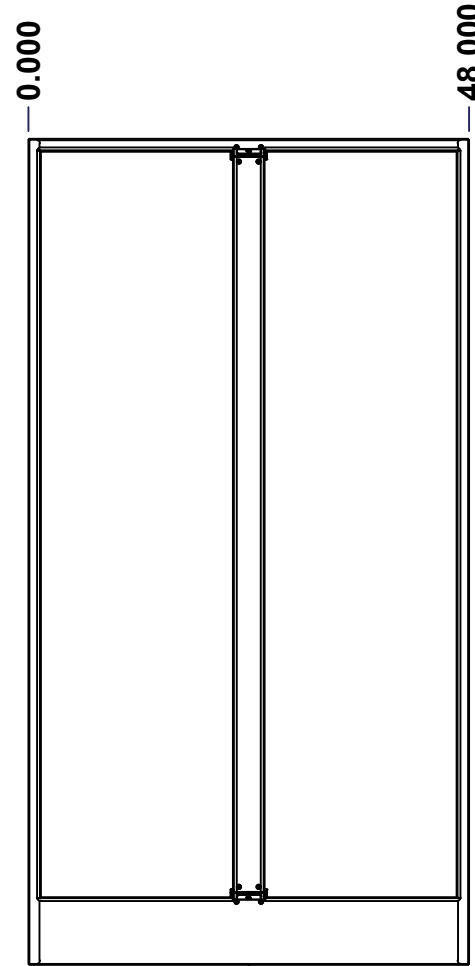

FRONT

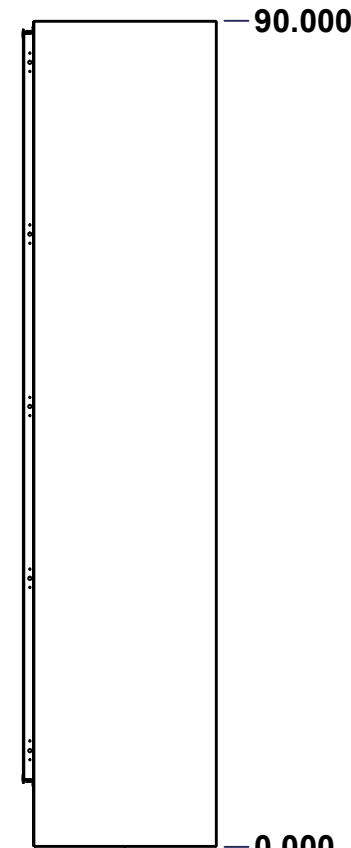

RIGHT

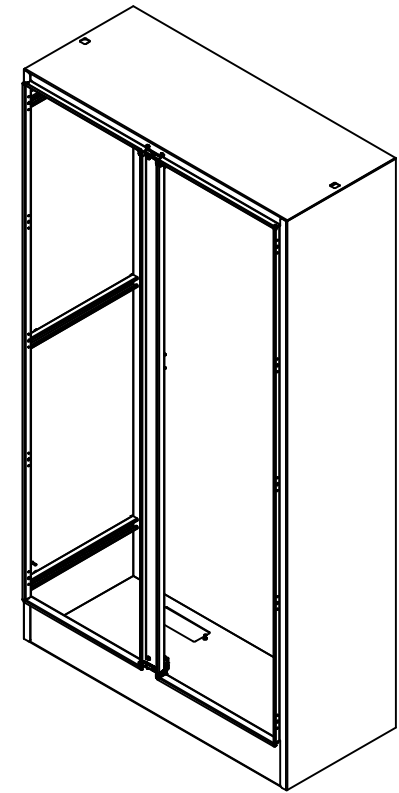

Isometric View

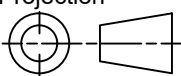

No.	Revisions	Date	By/Par

 Tél: (450) 979-4373 Fax: (450) 979-4626 www.exmweb.com		Flatness Aplatissement Max 3.0mm Projection 
Customer Client	Date	
Drawn By Dessiné Par	BoxCad: BoxCad	Date 10-Oct-19
Material Matière	12 Ga Cold Rolled A1008 CS Type B (2.5mm)	
Color Couleur	Asa-61 Grey	Finish Fini Smooth
Description	Detail Rev.	
9412DD 90" x 48" x 20" Body		
Part Number Numéro Pièce	Rev. 0	3 / 16
9412DD904820B		

SEE BILL OF MATERIAL ON LAST PAGE

This drawing is confidential and must not be reproduced or used without the consent of EXM

Ce dessin est confidentiel et ne doit pas être reproduit ou utilisé sans le consentement de EXM

STANDARD FEATURES ARE NOT LISTED IN THIS HOLE TABLE

HOLE TABLE - TOP VIEW (CUSTOM FEATURE ONLY)

CUT-OUT	XDIM	YDIM	DESCRIPTION
1	35.911	15.911	Struts CR400 17.500" (Inside)
2	11.911	15.911	Struts CR400 17.500" (Inside)
3	35.911	16.840	STUDS M6 x 10mm (Inside)
4	44.777	15.911	STUDS M6 x 10mm (Inside)
5	11.911	16.840	STUDS M6 x 10mm (Inside)
6	20.777	15.911	STUDS M6 x 10mm (Inside)

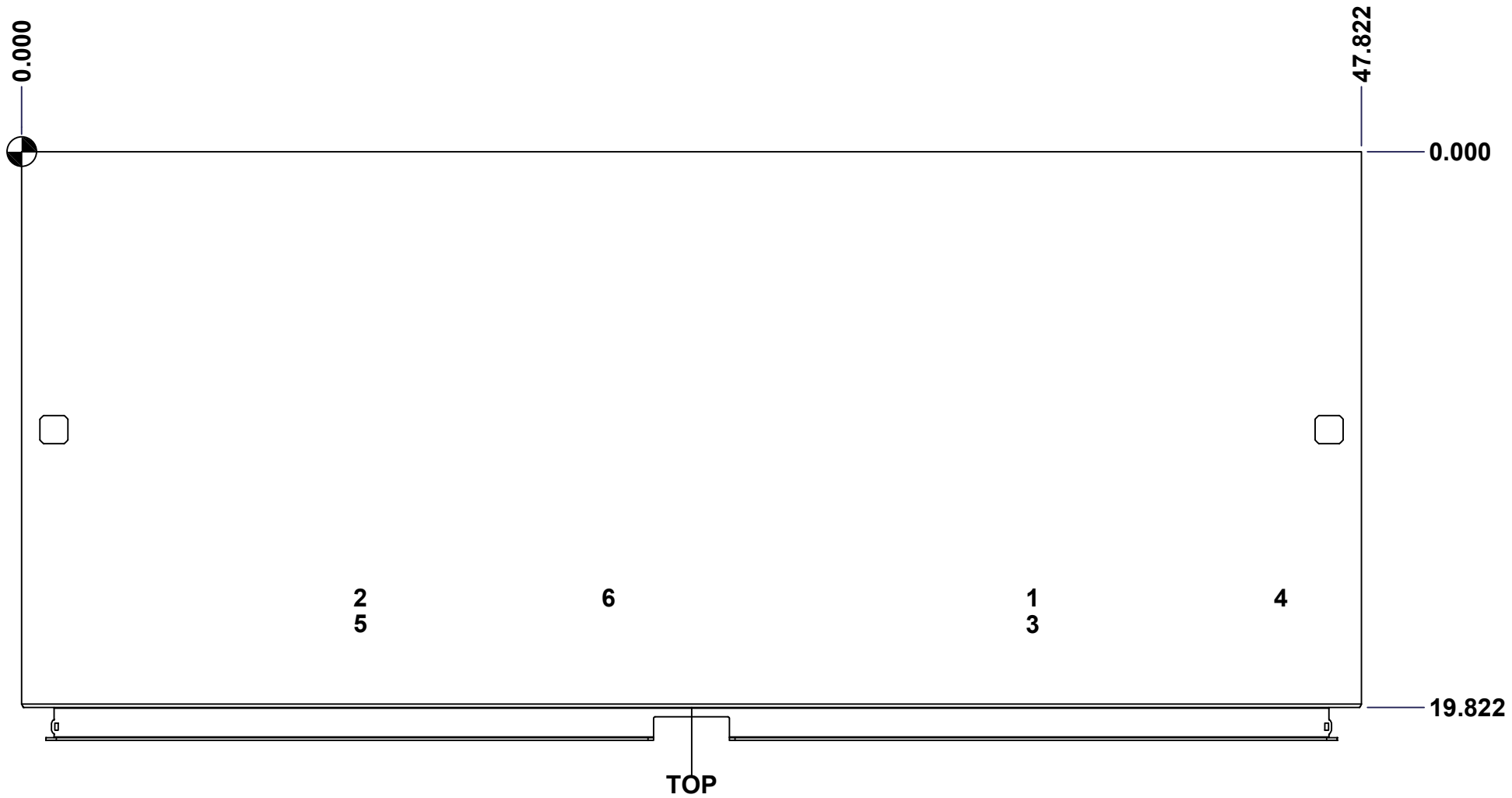

	Description 9412DD 90" x 48" x 20" Body	Status (NULL)
	Part Number Numéro Pièce 9412DD904820B	Rev. 4 0

This drawing is confidential and must not be reproduced or used without the consent of EXM

Ce dessin est confidentiel et ne doit pas être reproduit ou utilisé sans le consentement de EXM

STANDARD FEATURES ARE NOT LISTED IN THIS HOLE TABLE

HOLE TABLE - RIGHT VIEW (CUSTOM FEATURE ONLY)

CUT-OUT	XDIM	YDIM	DESCRIPTION
1	18.411	11.286	GND STUD M6 x 16mm (Inside)
2	6.536	84.107	STUDS M6 x 10mm (Inside)
3	13.286	84.107	STUDS M6 x 10mm (Inside)
4	6.536	7.857	STUDS M6 x 10mm (Inside)
5	13.286	7.857	STUDS M6 x 10mm (Inside)
6	6.536	45.982	STUDS M6 x 10mm (Inside)
7	13.286	45.982	STUDS M6 x 10mm (Inside)

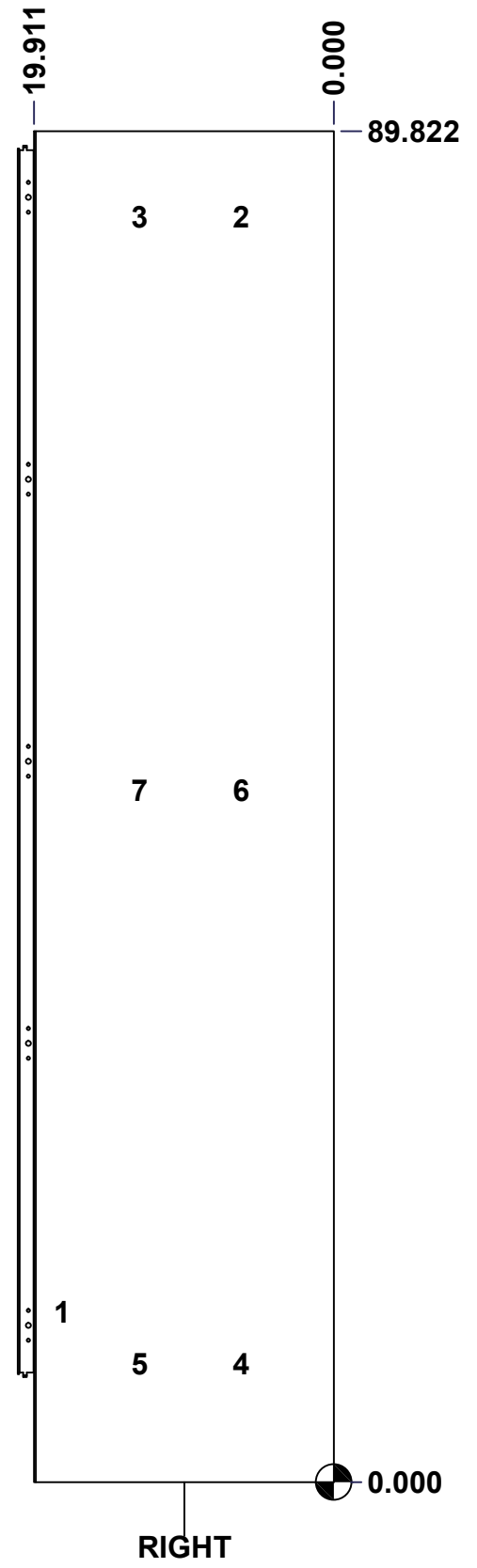

	Description	Status
	9412DD 90" x 48" x 20" Body	(NULL)
	Part Number Numéro Pièce	Rev.
	9412DD904820B	0 / 5
		16

This drawing is confidential and must not be reproduced or used without the consent of EXM

Ce dessin est confidentiel et ne doit pas être reproduit ou utilisé sans le consentement de EXM

STANDARD FEATURES ARE NOT LISTED IN THIS HOLE TABLE

HOLE TABLE - BOTTOM VIEW (CUSTOM FEATURE ONLY)

CUT-OUT	XDIM	YDIM	DESCRIPTION
1	7.286	3.411	GP STUD M6 x 16mm (Inside)
2	16.536	3.411	GP STUD M6 x 16mm (Inside)
3	31.286	3.411	GP STUD M6 x 16mm (Inside)
4	40.536	3.411	GP STUD M6 x 16mm (Inside)

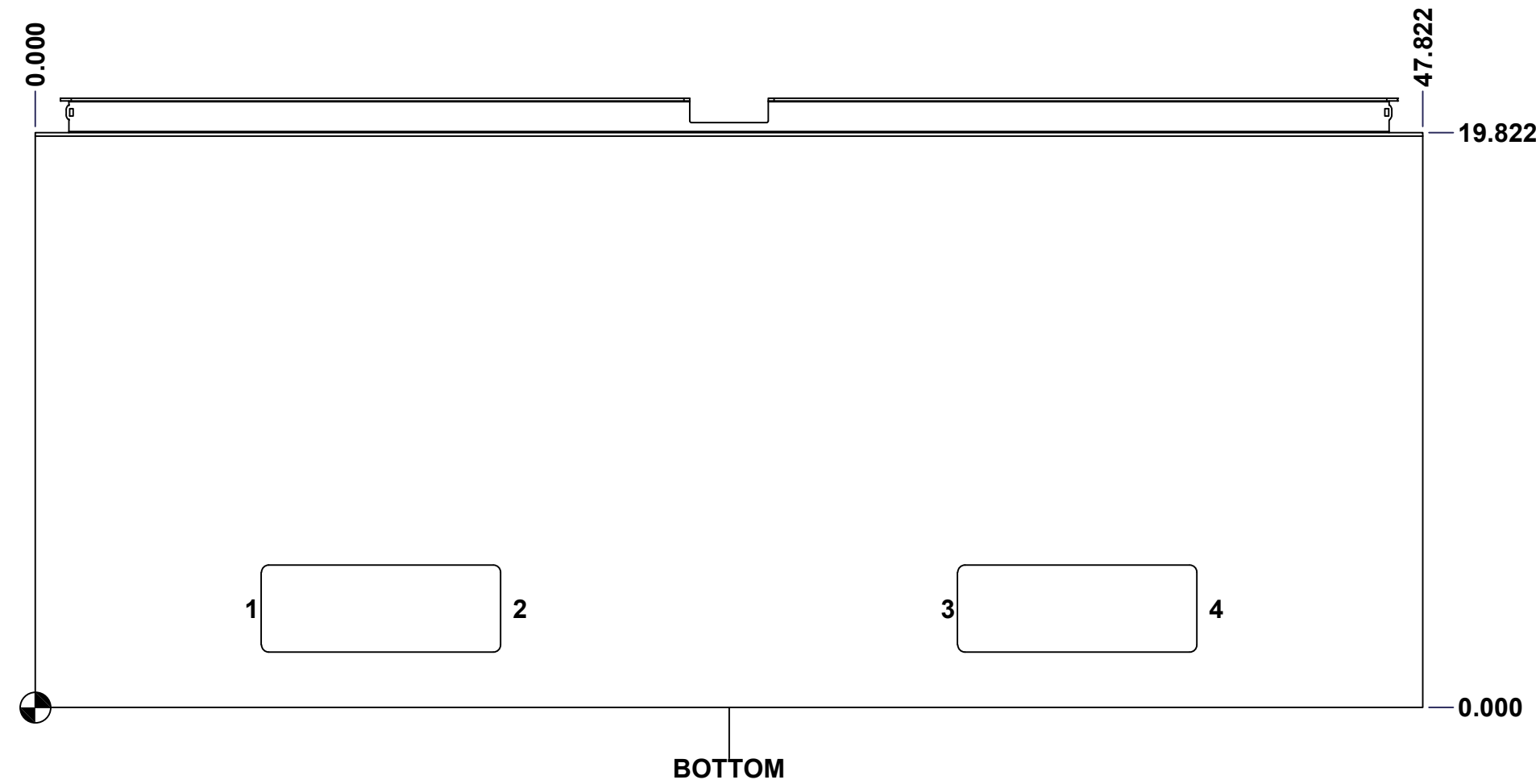

	Description	Status
	9412DD 90" x 48" x 20" Body	(NULL)
	Part Number Numéro Pièce	Rev.
	9412DD904820B	0
		6
		16

This drawing is confidential and must not be reproduced or used without the consent of EXM

Ce dessin est confidentiel et ne doit pas être reproduit ou utilisé sans le consentement de EXM

STANDARD FEATURES ARE NOT LISTED IN THIS HOLE TABLE

HOLE TABLE - LEFT VIEW (CUSTOM FEATURE ONLY)

CUT-OUT	XDIM	YDIM	DESCRIPTION
1	18.411	11.286	GND STUD M6 x 16mm (Inside)
2	6.536	84.107	STUDS M6 x 10mm (Inside)
3	13.286	84.107	STUDS M6 x 10mm (Inside)
4	6.536	7.857	STUDS M6 x 10mm (Inside)
5	13.286	7.857	STUDS M6 x 10mm (Inside)
6	6.536	45.982	STUDS M6 x 10mm (Inside)
7	13.286	45.982	STUDS M6 x 10mm (Inside)

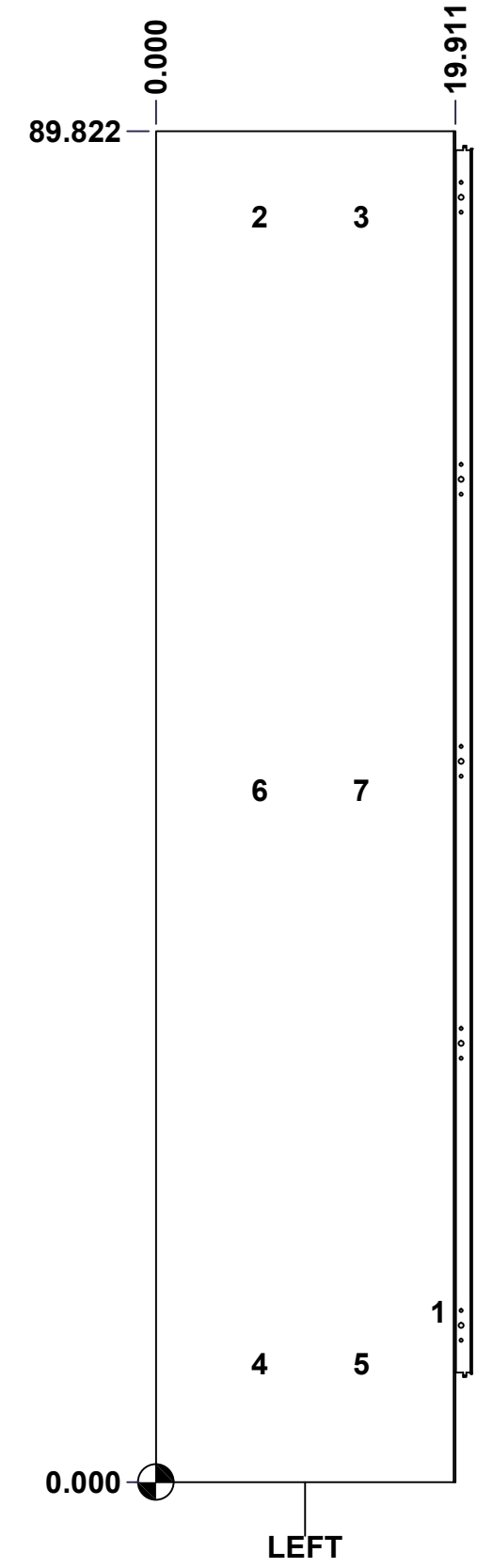

	Description	Status	
	9412DD 90" x 48" x 20" Body	(NULL)	
	Part Number Numéro Pièce	Rev.	
	9412DD904820B	0	7
			16

This drawing is confidential and must not be reproduced or used without the consent of EXM

Ce dessin est confidentiel et ne doit pas être reproduit ou utilisé sans le consentement de EXM

STANDARD FEATURES ARE NOT LISTED IN THIS HOLE TABLE			
HOLE TABLE - CENTER VIEW (CUSTOM FEATURE ONLY)			
CUT-OUT	XDIM	YDIM	DESCRIPTION
1	0.748	47.210	INTERLOCK STUD M6 x 16mm (Inside)
2	0.748	49.336	INTERLOCK STUD M6 x 16mm (Inside)
3	2.717	47.210	INTERLOCK STUD M6 x 16mm (Inside)
4	2.717	49.336	INTERLOCK STUD M6 x 16mm (Inside)

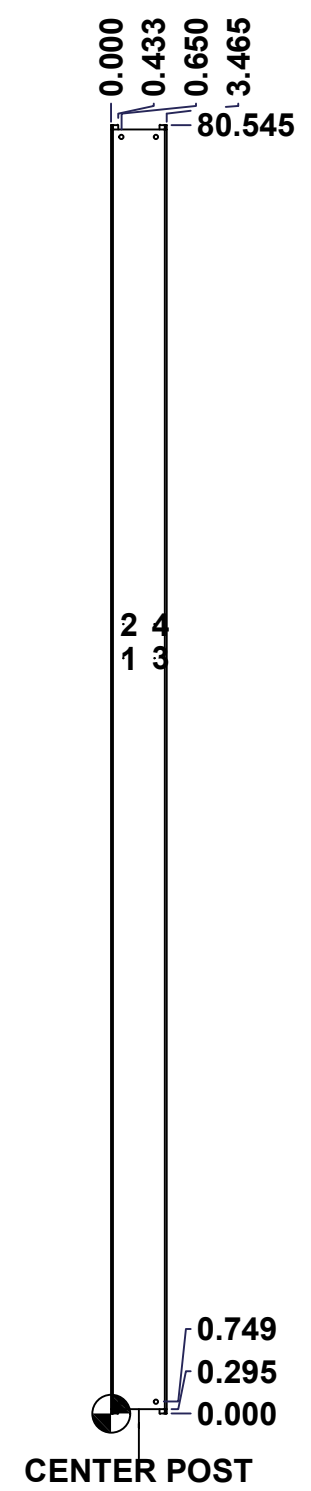

	Description	Status	
	9412DD 90" x 48" x 20" Body	(NULL)	
	Part Number Numéro Pièce	Rev.	
	9412DD904820B	0	8
			16

This drawing is confidential and must not be reproduced or used without the consent of EXM

Ce dessin est confidentiel et ne doit pas être reproduit ou utilisé sans le consentement de EXM

No.	Revisions	Date	By/Par

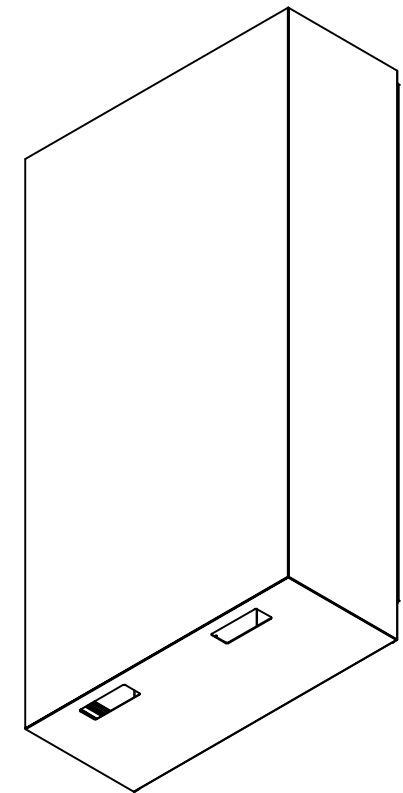

Isometric View



16	STK-Q-16030	0	Stud M6 x 10mm Steel
2	STK-Q-74910	0	Eyebolt Lifting Angle (15.500")
1	STK-P-02400S	0	Powder Paint (Asa-61 Grey / Smooth)
6	STK-Q-52250-20	2	Sasco Strut S5 (19.500" Long)
4	STK-Q-16055	1	M6 x 18mm Stud (No Paint Cap Required)
1	STK-A-75454	3	Center Post - Sealing Block with Latch Assembly (Large)
1	9412DD904820CP-P	0	9412DD 90" Center Post Part
1	9412DD904820BT-P	0	9412DD 48" x 20" Bottom Part
1	9412DD904820T-P	0	9412DD 48" x 20" Top Part
1	9412DD904820RS-P	0	9412DD 90" x 48" Right Part
1	9412DD904820LS-P	0	9412DD 90" x 48" Left Part
1	9412DD904820B-P	0	9412DD 90" x 48" Back Part
2	9412DD904820_CR400M S_17.5	0	Commercial Roll Mild Steel (17.5in long)
6	STK-Q-16080	0	Ground Stud M6 x 16mm Steel

Qty	Part Number	Rev	Description
Parts List			

Tél: (450) 979-4373 Fax: (450) 979-4626 www.exmweb.com	Flatness Aplatissement	Max 3.0mm
	Projection	
Customer Client	Date	
Drawn By Dessiné Par	BoxCad: BoxCad	Date 10-Oct-19
Material Matière	12 Ga Cold Rolled A1008 CS Type B (2.5mm)	
Color Couleur	Asa-61 Grey	Finish Fini Smooth
Description	9412DD 90" x 48" x 20" Body	Detail Rev.
Part Number Numéro Pièce	9412DD904820B	Rev. 0
		9 / 16

This drawing is confidential and must not be reproduced or used without the consent of EXM

Ce dessin est confidentiel et ne doit pas être reproduit ou utilisé sans le consentement de EXM

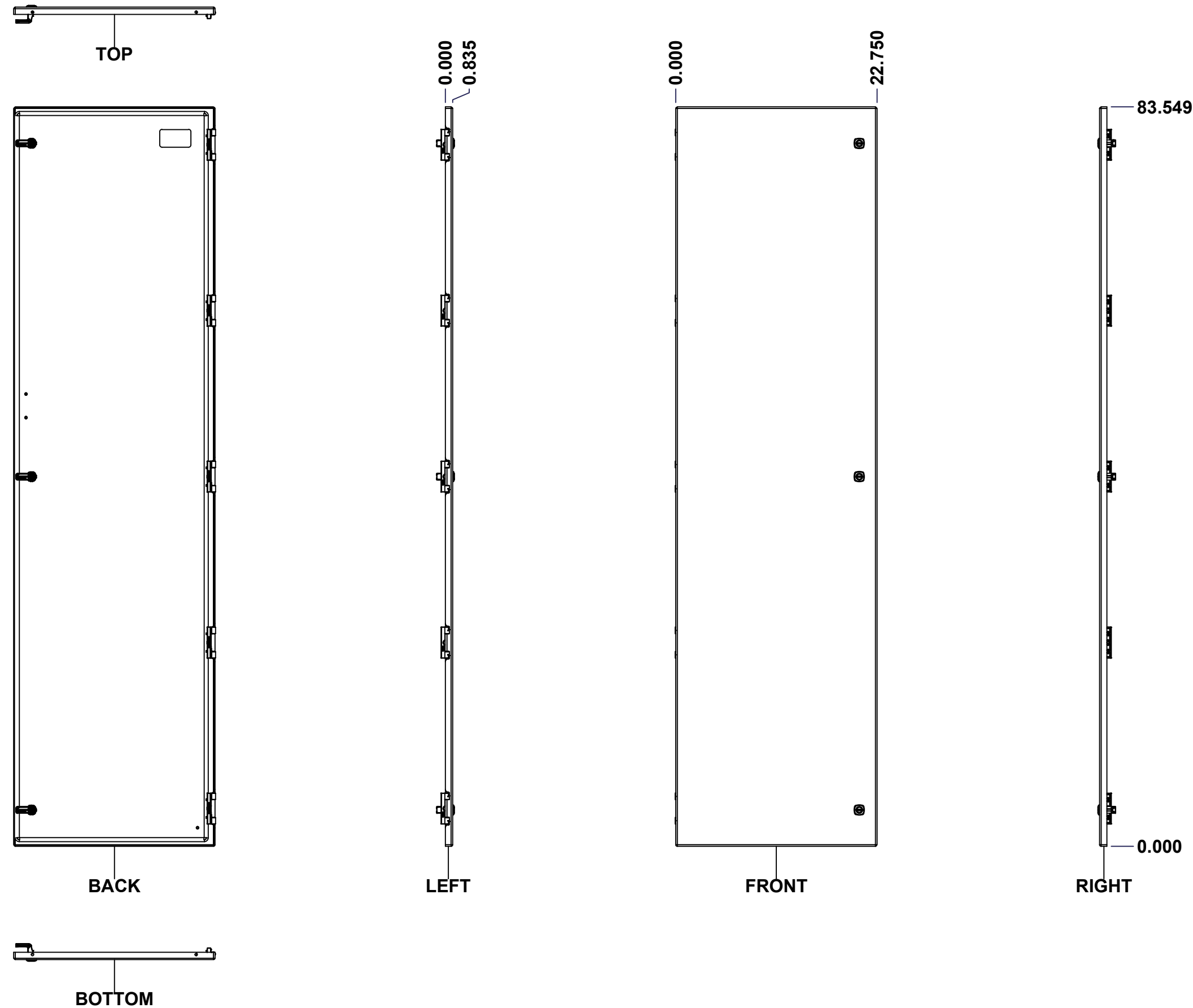

No.	Revisions	Date	By/Par

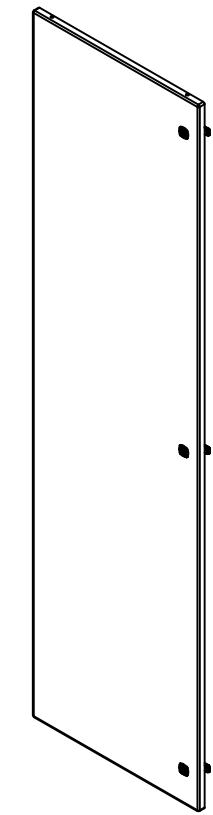

Isometric View

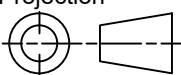

 Tél: (450) 979-4373 Fax: (450) 979-4626 www.exmweb.com		Flatness Aplatissement Max 3.0mm Projection 
Customer Client	Date	
Drawn By Dessiné Par	BoxCad: BoxCad	Date 10-Oct-19
Material Matière	12 Ga Cold Rolled A1008 CS Type B (2.5mm)	
Color Couleur	Asa-61 Grey	Finish Fini Smooth
Description 9412DD 90" x 48" Lock Door		Detail Rev.
Part Number Numéro Pièce	9412DD904820LD	Rev. 10 0 16

SEE BILL OF MATERIAL ON LAST PAGE

This drawing is confidential and must not be reproduced or used without the consent of EXM

Ce dessin est confidentiel et ne doit pas être reproduit ou utilisé sans le consentement de EXM

STANDARD FEATURES ARE NOT LISTED IN THIS HOLE TABLE

HOLE TABLE - FRONT VIEW (CUSTOM FEATURE ONLY)

CUT-OUT	XDIM	YDIM	DESCRIPTION
1	20.750	4.118	LOCK 889 SCQ4-SL @ 0.0°
2	2.000	2.118	GND STUD M6 x 16mm (Inside)
3	20.750	79.430	LOCK 889 SCQ4-SL @ 0.0°
4	20.750	41.774	LOCK 889 SCQ4-SL @ 0.0°
5	21.372	48.435	STUDS M6 x 18mm (Inside)
6	21.372	51.113	STUDS M6 x 18mm (Inside)

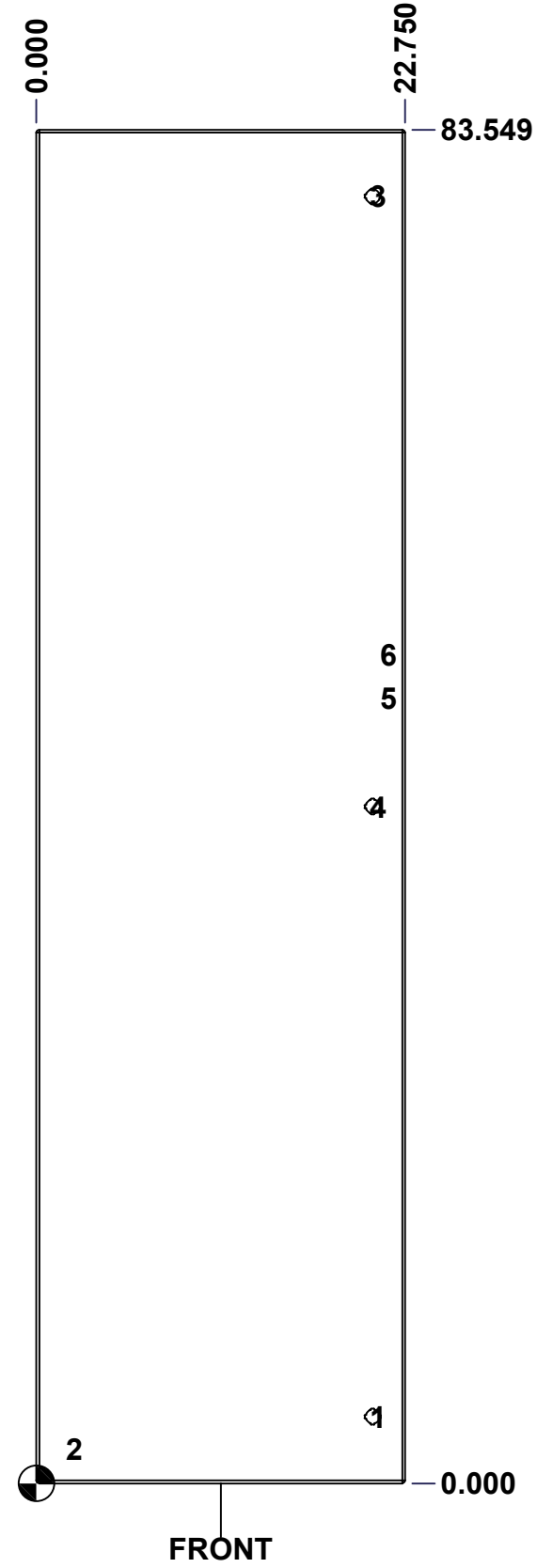

	Description	Status
	9412DD 90" x 48" Lock Door	(NULL)
Part Number Numéro Pièce 9412DD904820LD	Rev.	11
	0	16

This drawing is confidential and must not be reproduced or used without the consent of EXM

Ce dessin est confidentiel et ne doit pas être reproduit ou utilisé sans le consentement de EXM

No.	Revisions	Date	By/Par

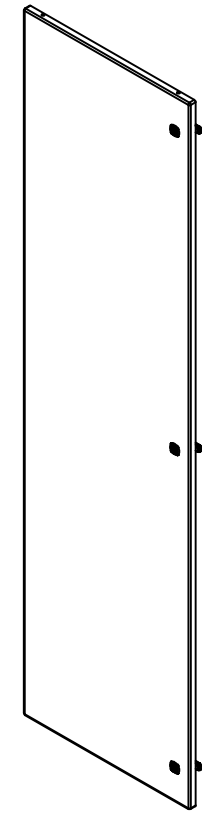

Isometric View

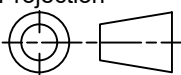

 Tél: (450) 979-4373 Fax: (450) 979-4626 www.exmweb.com		Flatness Aplatissement Max 3.0mm
Customer Client		Projection 
Drawn By / Dessiné Par: BoxCad: BoxCad		Date: 10-Oct-19
Material / Matière: 12 Ga Cold Rolled A1008 CS Type B (2.5mm)		
Color / Couleur: Asa-61 Grey	Finish / Fini: Smooth	
Description: 9412DD 90" x 48" Lock Door		Detail Rev.
Part Number / Numéro Pièce: 9412DD904820LD		Rev. 0 / 12 / 16

QTY	Part Number	Rev	Description
2	STK-Q-16050	1	Stud M6 x 18mm Steel
1	STK-Q-16080	0	Ground Stud M6 x 16mm Steel
1	STK-P-02400S	0	Powder Paint (Asa-61 Grey / Smooth)
1	STK-S-00100	0	3.5" x 2" Silver Milar Flexcon Sticker
1	9412DD904820DG	0	9412DD 90" x 48" Door Gasket
1	9412DD904820LD-P	0	9412DD 90" x 48" Slave Door Part
5	STK-K-09860	7	Cabinet Hinge with Captive Pins
3	STK-K-12580	0	9412 1/4 Turn Lock
Parts List			

This drawing is confidential and must not be reproduced or used without the consent of EXM

Ce dessin est confidentiel et ne doit pas être reproduit ou utilisé sans le consentement de EXM

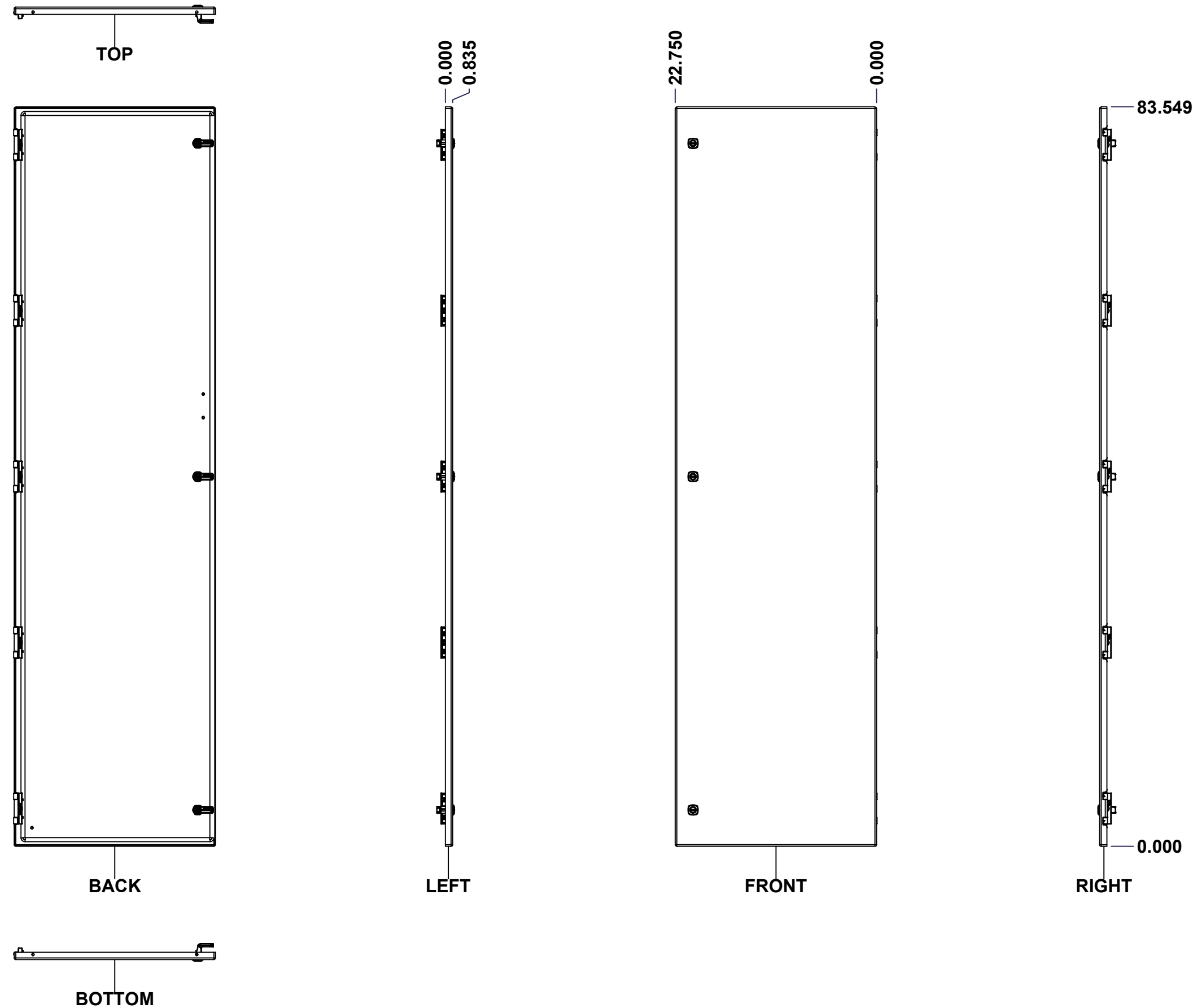

No.	Revisions	Date	By/Par

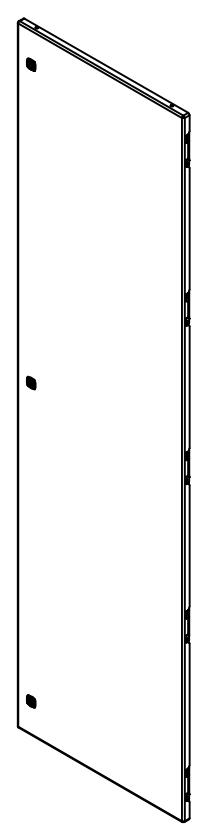

Isometric View

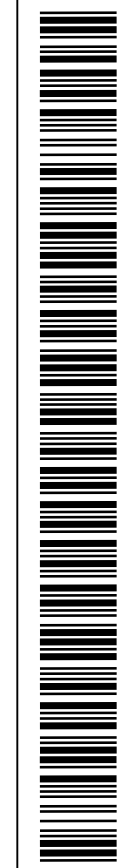

 Tél: (450) 979-4373 Fax: (450) 979-4626 www.exmweb.com		Flatness Aplatissement	
		Max 3.0mm	
Customer Client		Date	
Drawn By Dessiné Par BoxCad: BoxCad		Date 10-Oct-19	
Material Matière 12 Ga Cold Rolled A1008 CS Type B (2.5mm)			
Color Couleur Asa-61 Grey		Finish Fini Smooth	
Description 9412DD 90" x 48" Flange Door			Detail Rev.
Part Number Numéro Pièce 9412DD904820FD		Rev. 0	13 16

SEE BILL OF MATERIAL ON LAST PAGE

This drawing is confidential and must not be reproduced or used without the consent of EXM

Ce dessin est confidentiel et ne doit pas être reproduit ou utilisé sans le consentement de EXM

STANDARD FEATURES ARE NOT LISTED IN THIS HOLE TABLE

HOLE TABLE - FRONT VIEW (CUSTOM FEATURE ONLY)

CUT-OUT	XDIM	YDIM	DESCRIPTION
1	20.750	79.430	LOCK 889 SCQ4-SL @ 180.0°
2	20.750	41.774	LOCK 889 SCQ4-SL @ 180.0°
3	20.750	4.118	LOCK 889 SCQ4-SL @ 180.0°
4	2.000	2.118	GND STUD M6 x 16mm (Inside)
5	21.372	48.435	STUDS M6 x 18mm (Inside)
6	21.372	51.113	STUDS M6 x 18mm (Inside)

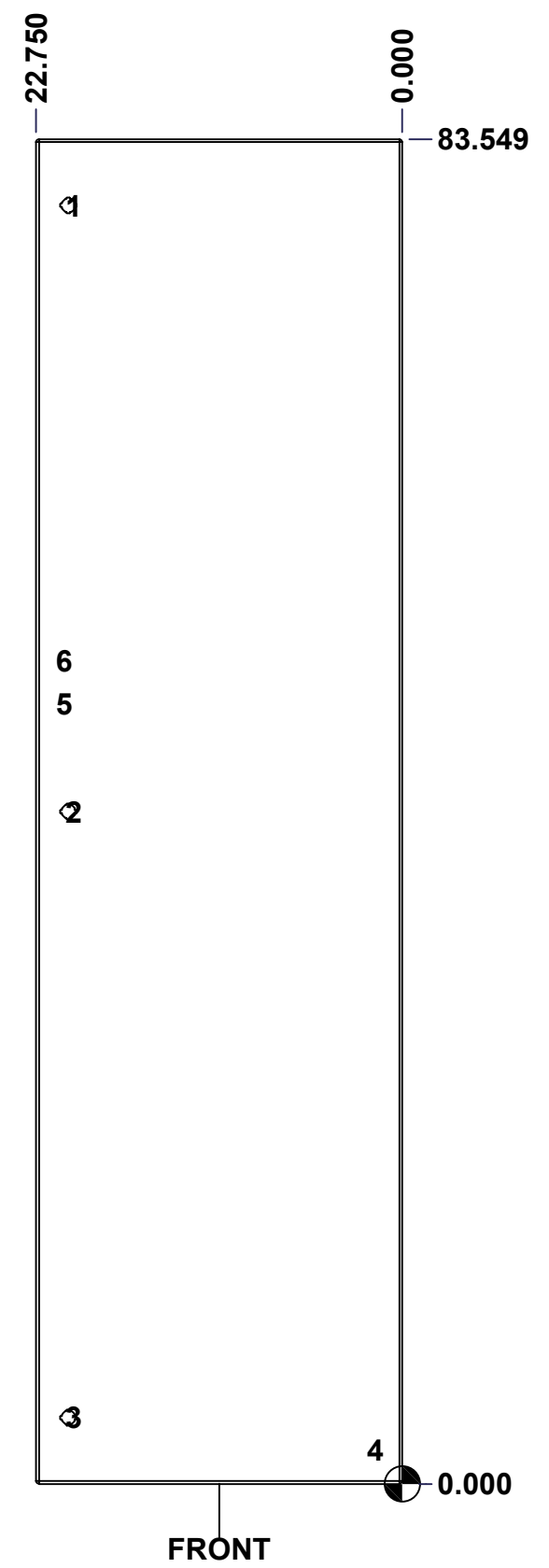

	Description	Status
	9412DD 90" x 48" Flange Door	(NULL)
	Part Number Numéro Pièce	Rev.
	9412DD904820FD	0 / 14
		16

This drawing is confidential and must not be reproduced or used without the consent of EXM

Ce dessin est confidentiel et ne doit pas être reproduit ou utilisé sans le consentement de EXM

No.	Revisions	Date	By/Par

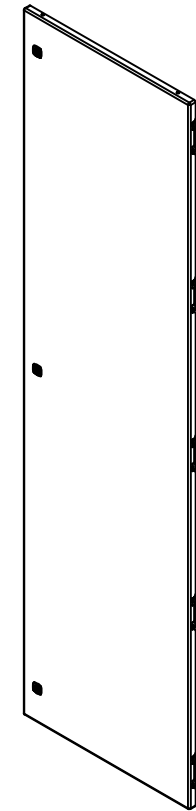

Isometric View

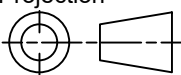

 Tél: (450) 979-4373 Fax: (450) 979-4626 www.exmweb.com	Flatness Aplatissement	Max 3.0mm
	Projection	
Customer Client	Date	
Drawn By Dessiné Par	BoxCad: BoxCad	Date 10-Oct-19
Material Matière	12 Ga Cold Rolled A1008 CS Type B (2.5mm)	
Color Couleur	Asa-61 Grey	Finish Fini Smooth
Description	Detail Rev.	
9412DD 90" x 48" Flange Door		
Part Number Numéro Pièce	Rev.	15
9412DD904820FD	0	16

QTY	Part Number	Rev	Description
2	STK-Q-16050	1	Stud M6 x 18mm Steel
1	STK-Q-16080	0	Ground Stud M6 x 16mm Steel
1	STK-P-02400S	0	Powder Paint (Asa-61 Grey / Smooth)
1	9412DD904820DG	0	9412DD 90" x 48" Door Gasket
1	9412DD904820FD-P	0	9412DD 90" x 48" Master Door Part
5	STK-K-09860	7	Cabinet Hinge with Captive Pins
3	STK-K-12580	0	9412 1/4 Turn Lock
Parts List			

All knockouts are actual size / Les disques défonçables sont grandeur réel
 All dimensions are before paint / Toutes les dimensions sont avant peinture

This drawing is confidential and must not be reproduced or used without the consent of EXM

Ce dessin est confidentiel et ne doit pas être reproduit ou utilisé sans le consentement de EXM

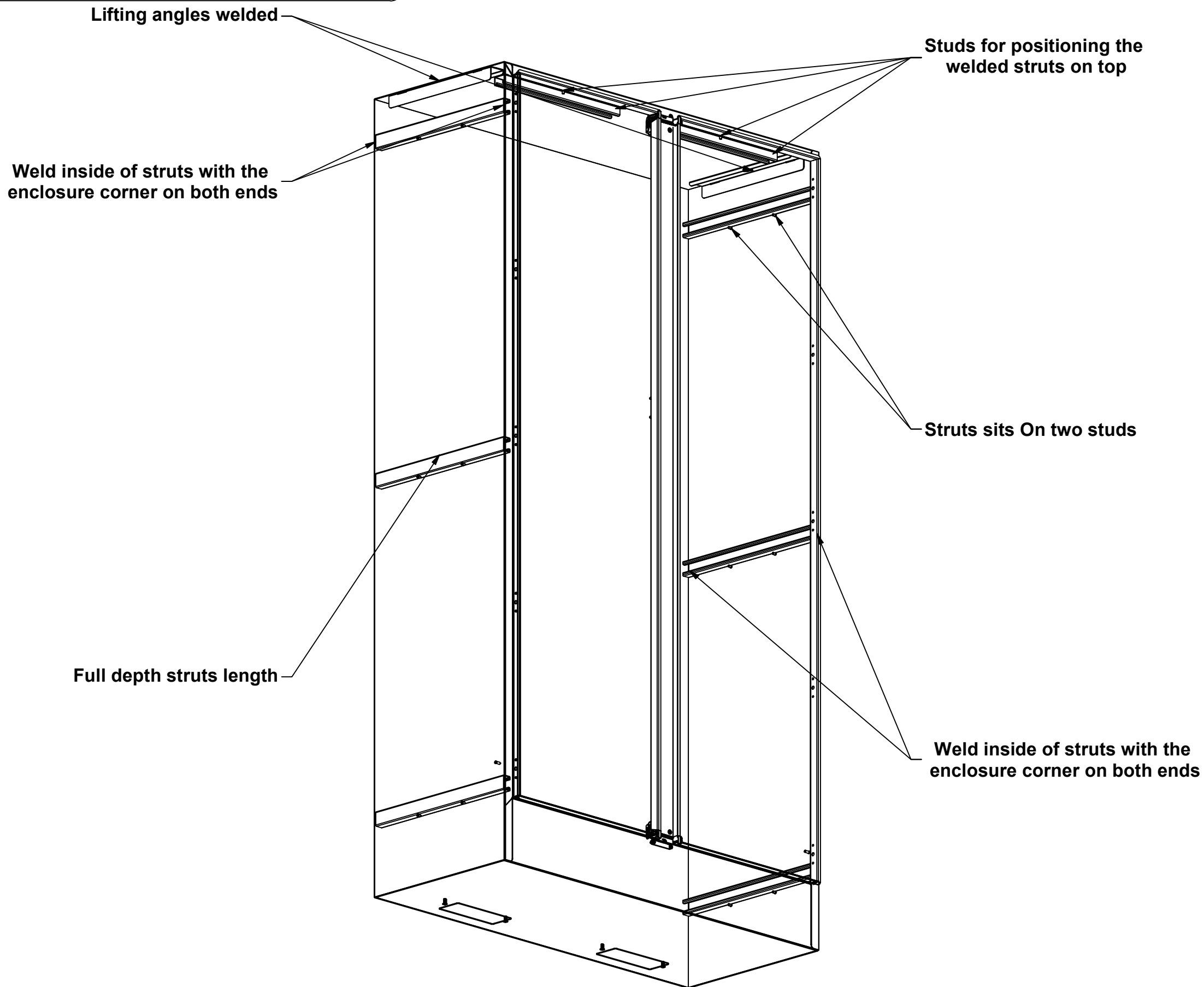

No.	Revisions	Date	By/Par

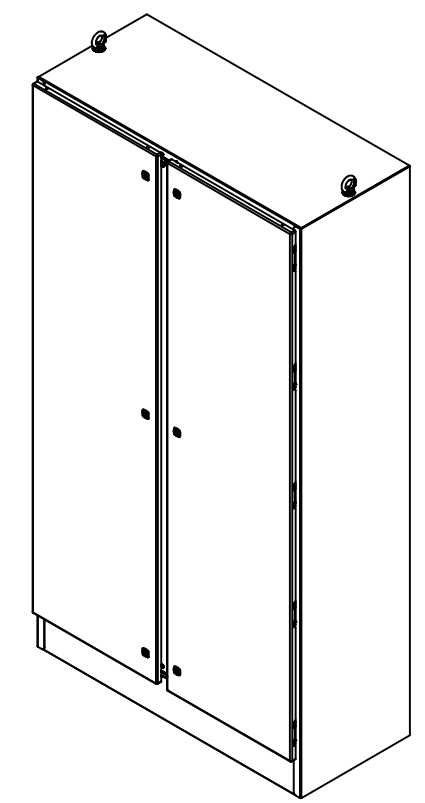

Isometric View

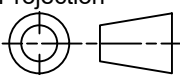

 Tél: (450) 979-4373 Fax: (450) 979-4626 www.exmweb.com	Flatness Aplatissement
	Max 3.0mm
Projection	
Customer Client	Date
Drawn By Dessiné Par BoxCad	Date 11-Aug-05
Material Matière 12 Ga Cold Rolled A1008 CS Type B (2.5mm)	
Color Couleur Asa-61 Grey	Finish Fini Smooth
Description 9412DD 90" x 48" x 20" Assembly	Detail Rev.
Part Number Numéro Pièce 9412DD Welding Details	Rev. 0
	16 / 16