

This drawing is confidential and must not be reproduced or used without the consent of EXM

Ce dessin est confidentiel et ne doit pas être reproduit ou utilisé sans le consentement de EXM

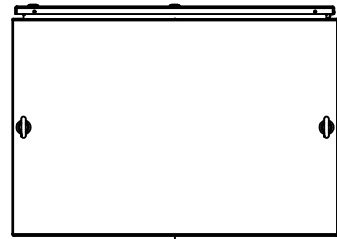

TOP

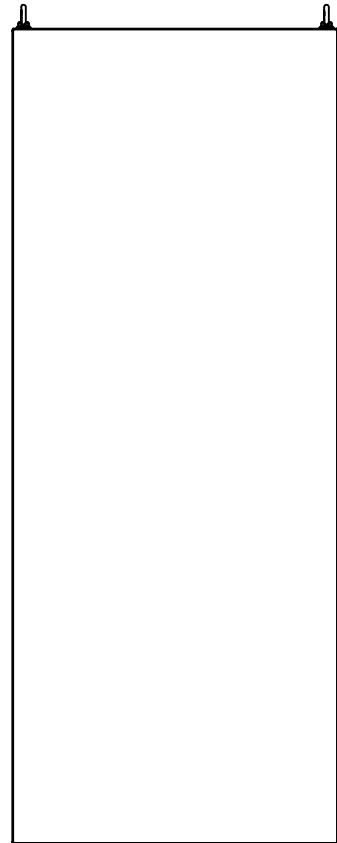

BACK

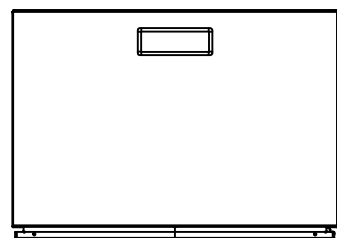

BOTTOM

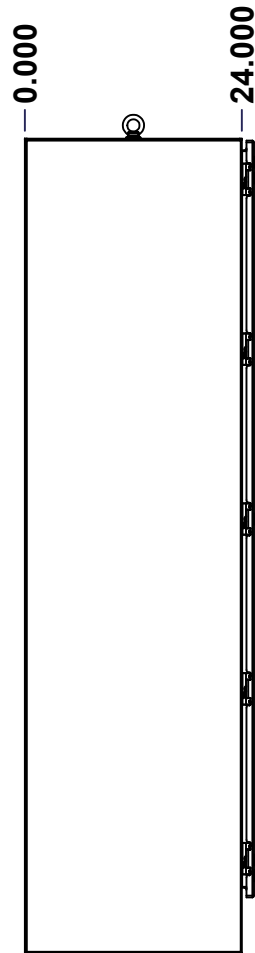

LEFT

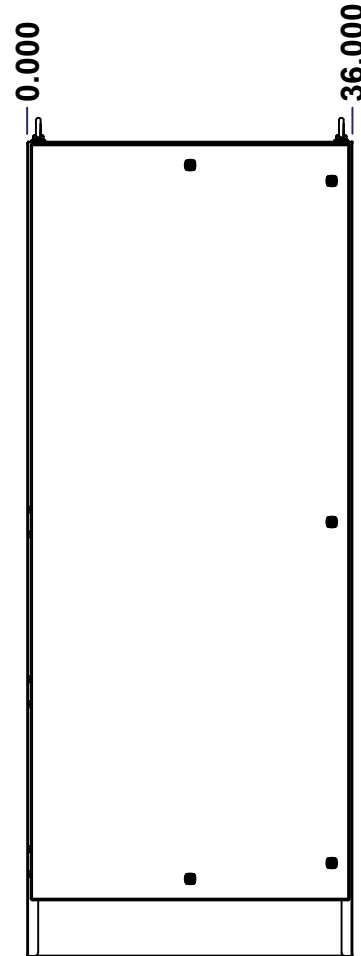

FRONT

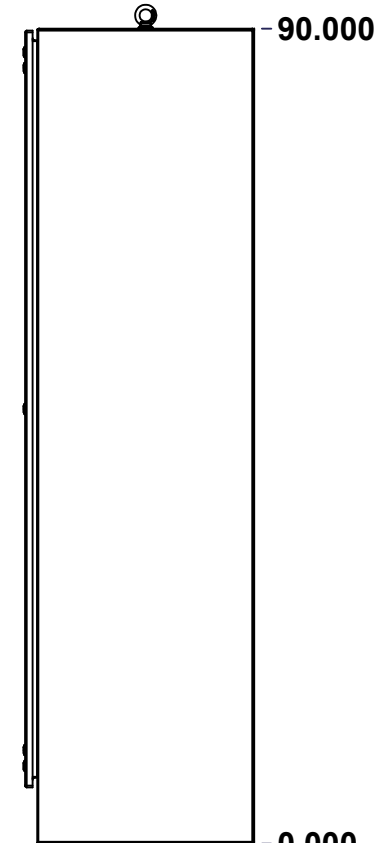

RIGHT

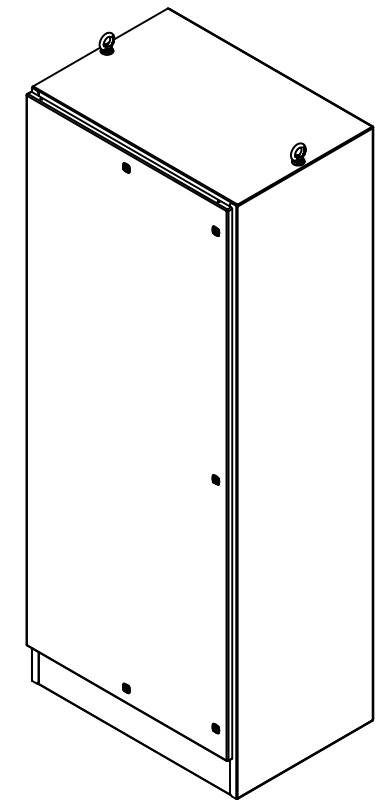

Isometric View

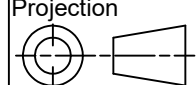

No.	Revisions	Date	By/Par

 Tél: (450) 979-4373 Fax: (450) 979-4626 www.exmweb.com		Flatness Aplatissement Max 3.0mm Projection 
Customer Client	Date	
Drawn By Dessiné Par	BoxCad: BoxCad	Date 23-Nov-21
Material Matière	12 Ga Cold Rolled A1008 CS Type B (2.5mm)	
Color Couleur	Asa-61 Grey	Finish Fini Smooth
Description	Detail Rev.	
9412 90" x 36" x 24" Assembly		
Part Number Numéro Pièce	Rev. 0	1 / 2
9412ST903624		

SEE BILL OF MATERIAL ON LAST PAGE

This drawing is confidential and must not be reproduced or used without the consent of EXM

Ce dessin est confidentiel et ne doit pas être reproduit ou utilisé sans le consentement de EXM

NOTE	
ITEM	DESCRIPTION
1	NEMA 4/12 Enclosure
2	C/W Standard ground studs on box and cover
3	W/O Standard door stiffener
4	W/O Inner panel
5	C/W Standard inner panel mounting studs
6	C/W Eyebolts
7	C/W Struts installed (Included)

No.	Revisions	Date	By/Par

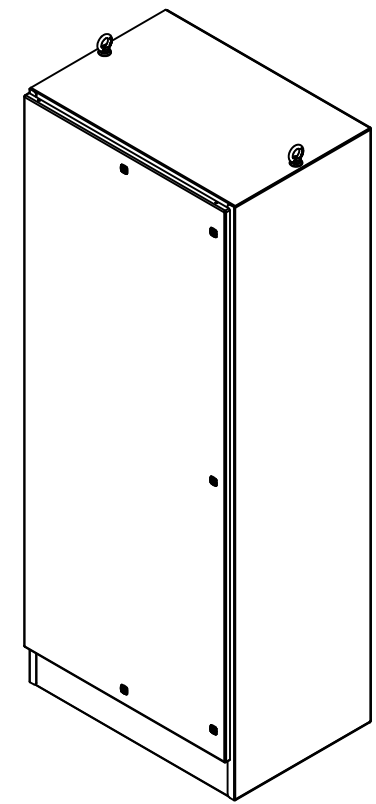

Isometric View

PACKING		
ITEM	QTY	DESCRIPTION
Cardboard sleeve	2	Top and Bottom
Cardboard strip	2	Between back of enclosure and inner panel
Plastic bag	1	To protect cover surface and inside gasket
Cardboard corner	4	To reinforced for the plastic strap tightening
Plastic strap - Black	2	To Squeeze 2 cardboard sleeve together
Packaging label	3	White label with PN
Plastic strap- Green	2	To secure the enclosure to the wood pallet
Wood Pallet	1	2" deeper and 3" larger than enclosure size

Qty	Part Number	Rev	Description
1	9412ST903624GP	0	9412 Gland Plate
1	880EB14	2	Eye Bolt M14 (Pack of 2)
1	9412ST903624C	0	9412 90" x 36" Cover
1	9412ST903624B	0	9412 90" x 36" x 24" Body
5	STK-Q-04050-10	8	M6 x 10mm Hexagon Socket Head Machine Screw with Nyseal
Parts List			

		Tél: (450) 979-4373 Fax: (450) 979-4626 www.exmweb.com		Flatness Aplatissement Max 3.0mm Projection 	
Customer Client		Date		Date 23-Nov-21	
Drawn By Dessiné Par		BoxCad: BoxCad		Date 23-Nov-21	
Material Matière		12 Ga Cold Rolled A1008 CS Type B (2.5mm)			
Color Couleur		Asa-61 Grey		Finish Fini Smooth	
Description				Detail Rev.	
9412 90" x 36" x 24" Assembly					
Part Number Numéro Pièce				Rev.	
9412ST903624				0 / 2	

This drawing is confidential and must not be reproduced or used without the consent of EXM

Ce dessin est confidentiel et ne doit pas être reproduit ou utilisé sans le consentement de EXM



TOP



BACK

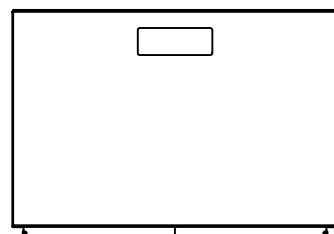

BOTTOM

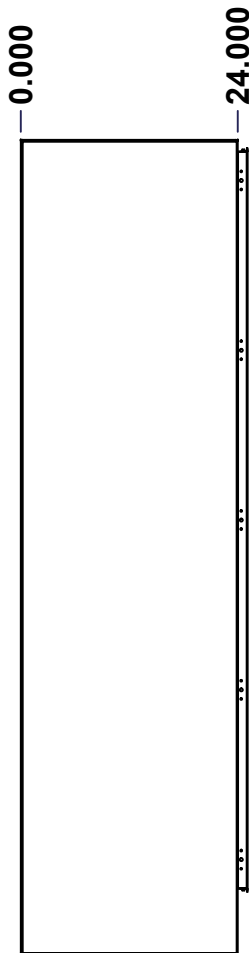

LEFT

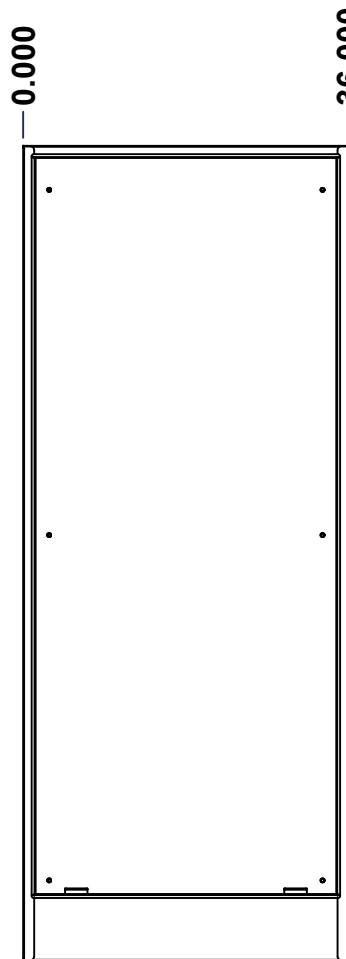

FRONT

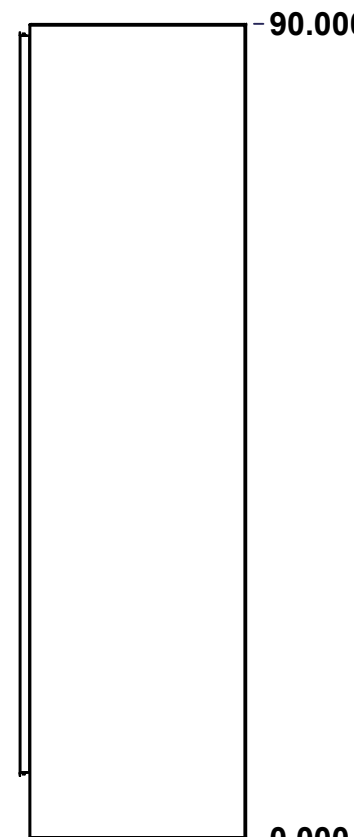

RIGHT

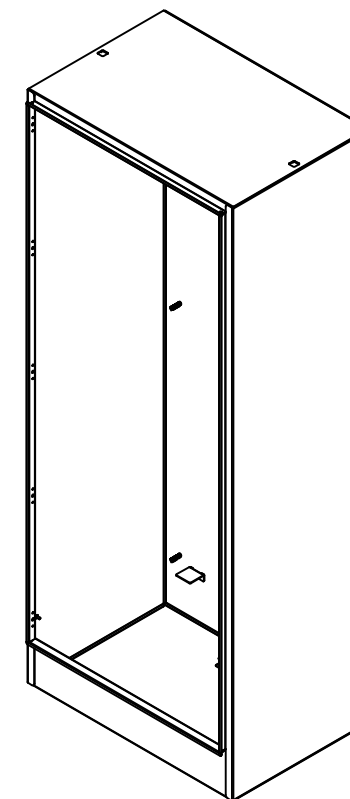

Isometric View

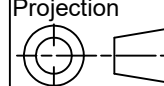

No.	Revisions	Date	By/Par

 Tél: (450) 979-4373 Fax: (450) 979-4626 www.exmweb.com		Flatness Aplatissement Max 3.0mm Projection 
Customer Client	Date	Date
Drawn By Dessiné Par	BoxCad: BoxCad	23-Nov-21
Material Matière	12 Ga Cold Rolled A1008 CS Type B (2.5mm)	
Color Couleur	Asa-61 Grey	Finish Fini: Smooth
Description	9412 90" x 36" x 24" Body	
Part Number Numéro Pièce	Rev. 0	1/2

SEE BILL OF MATERIAL ON LAST PAGE

9412ST903624B

This drawing is confidential and must not be reproduced or used without the consent of EXM

Ce dessin est confidentiel et ne doit pas être reproduit ou utilisé sans le consentement de EXM

STANDARD FEATURES ARE NOT LISTED IN THIS HOLE TABLE

HOLE TABLE - TOP VIEW (CUSTOM FEATURE ONLY)

CUT-OUT	XDIM	YDIM	DESCRIPTION
1	17.911	19.911	Struts CR400 27.500" (Inside)
2	17.911	19.911	STUDS M6 x 10mm (Inside)
3	7.161	19.911	STUDS M6 x 10mm (Inside)
4	28.661	19.911	STUDS M6 x 10mm (Inside)

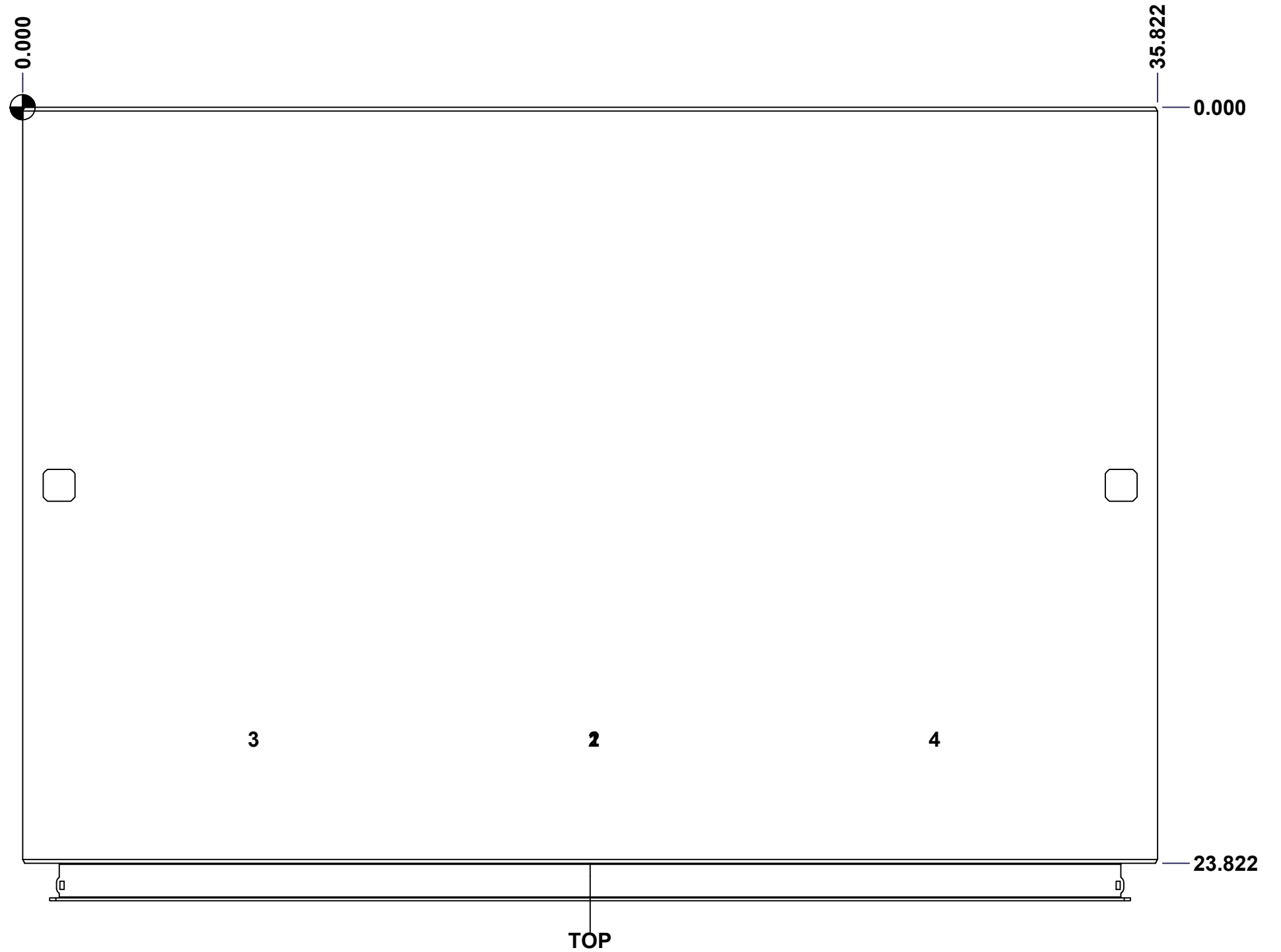

	Description	Status	
	9412 90" x 36" x 24" Body	Released	
	Part Number Numéro Pièce	Rev.	2 / 7
	9412ST903624B	0	

This drawing is confidential and must not be reproduced or used without the consent of EXM

Ce dessin est confidentiel et ne doit pas être reproduit ou utilisé sans le consentement de EXM

STANDARD FEATURES ARE NOT LISTED IN THIS HOLE TABLE			
HOLE TABLE - BOTTOM VIEW (CUSTOM FEATURE ONLY)			
CUT-OUT	XDIM	YDIM	DESCRIPTION
1	13.286	3.411	GP STUD M6 x 16mm (Inside)
2	22.536	3.411	GP STUD M6 x 16mm (Inside)

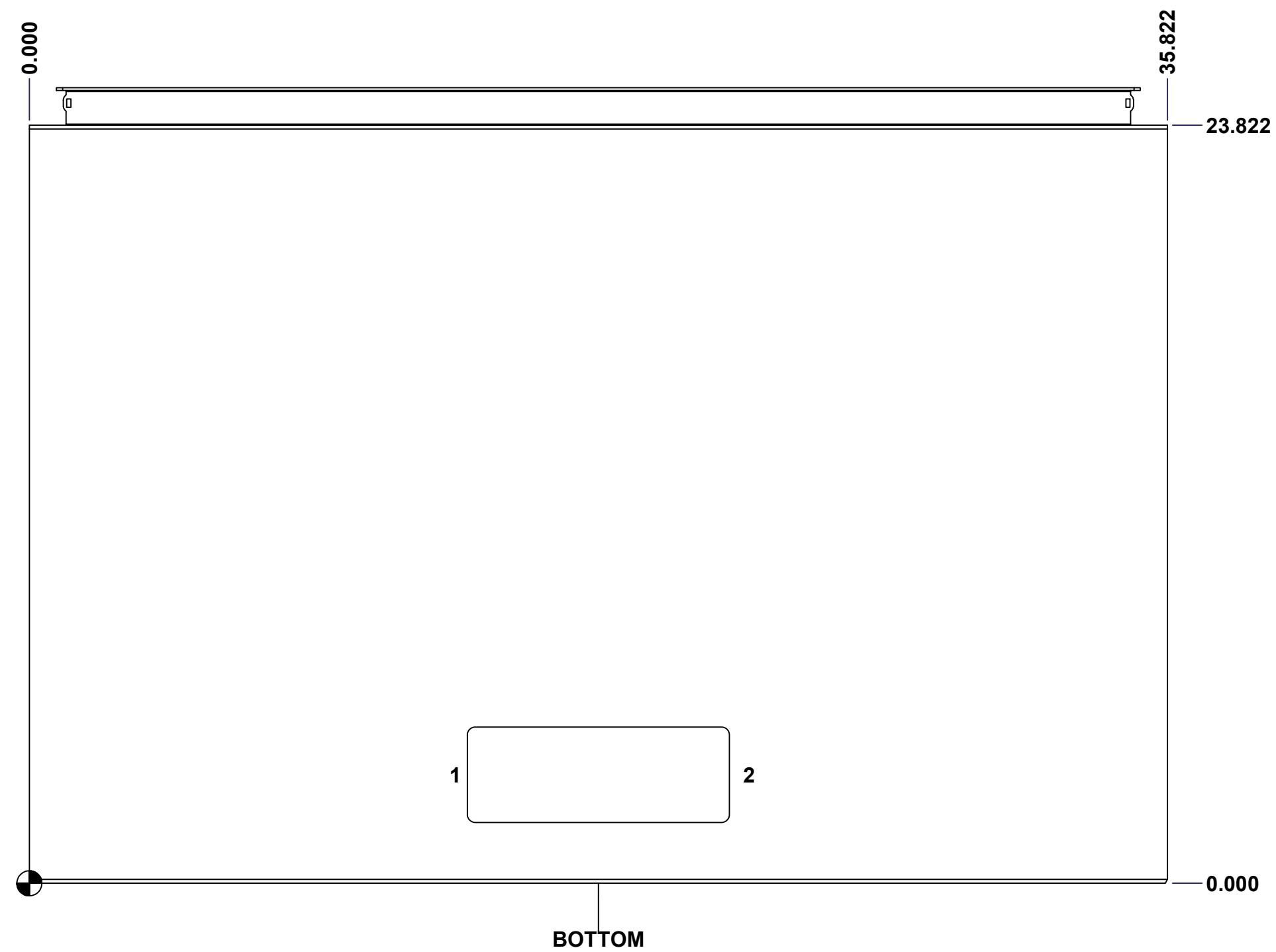

	Description	Status
	9412 90" x 36" x 24" Body	Released
	Part Number Numéro Pièce	Rev.
	9412ST903624B	0
		4
		7

This drawing is confidential and must not be reproduced or used without the consent of EXM

Ce dessin est confidentiel et ne doit pas être reproduit ou utilisé sans le consentement de EXM

STANDARD FEATURES ARE NOT LISTED IN THIS HOLE TABLE			
HOLE TABLE - LEFT VIEW (CUSTOM FEATURE ONLY)			
CUT-OUT	XDIM	YDIM	DESCRIPTION
1	22.411	9.286	GND STUD M6 x 16mm (Inside)

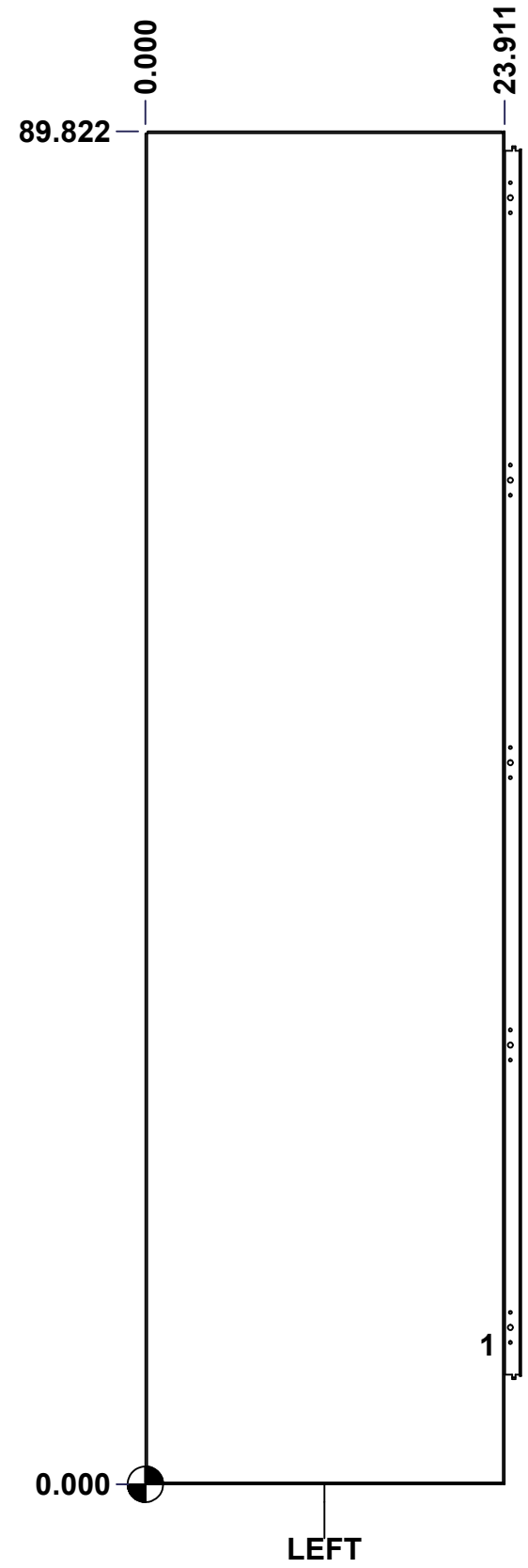

	Description	Status	
	9412 90" x 36" x 24" Body	Released	
	Part Number Numéro Pièce	Rev.	
	9412ST903624B	0	5 / 7

This drawing is confidential and must not be reproduced or used without the consent of EXM

Ce dessin est confidentiel et ne doit pas être reproduit ou utilisé sans le consentement de EXM

STANDARD FEATURES ARE NOT LISTED IN THIS HOLE TABLE

HOLE TABLE - BACK VIEW (CUSTOM FEATURE ONLY)

CUT-OUT	XDIM	YDIM	DESCRIPTION
1	2.786	8.786	IP STUD M10 x 40mm (Inside)
2	33.036	8.786	IP STUD M10 x 40mm (Inside)
3	2.786	46.911	IP STUD M10 x 40mm (Inside)
4	33.036	46.911	IP STUD M10 x 40mm (Inside)
5	2.786	85.036	IP STUD M10 x 40mm (Inside)
6	33.036	85.036	IP STUD M10 x 40mm (Inside)
-----	-----	-----	-----
7	30.036	7.411	IP SUPPORT ANGLE (Inside)
8	5.786	7.411	IP SUPPORT ANGLE (Inside)

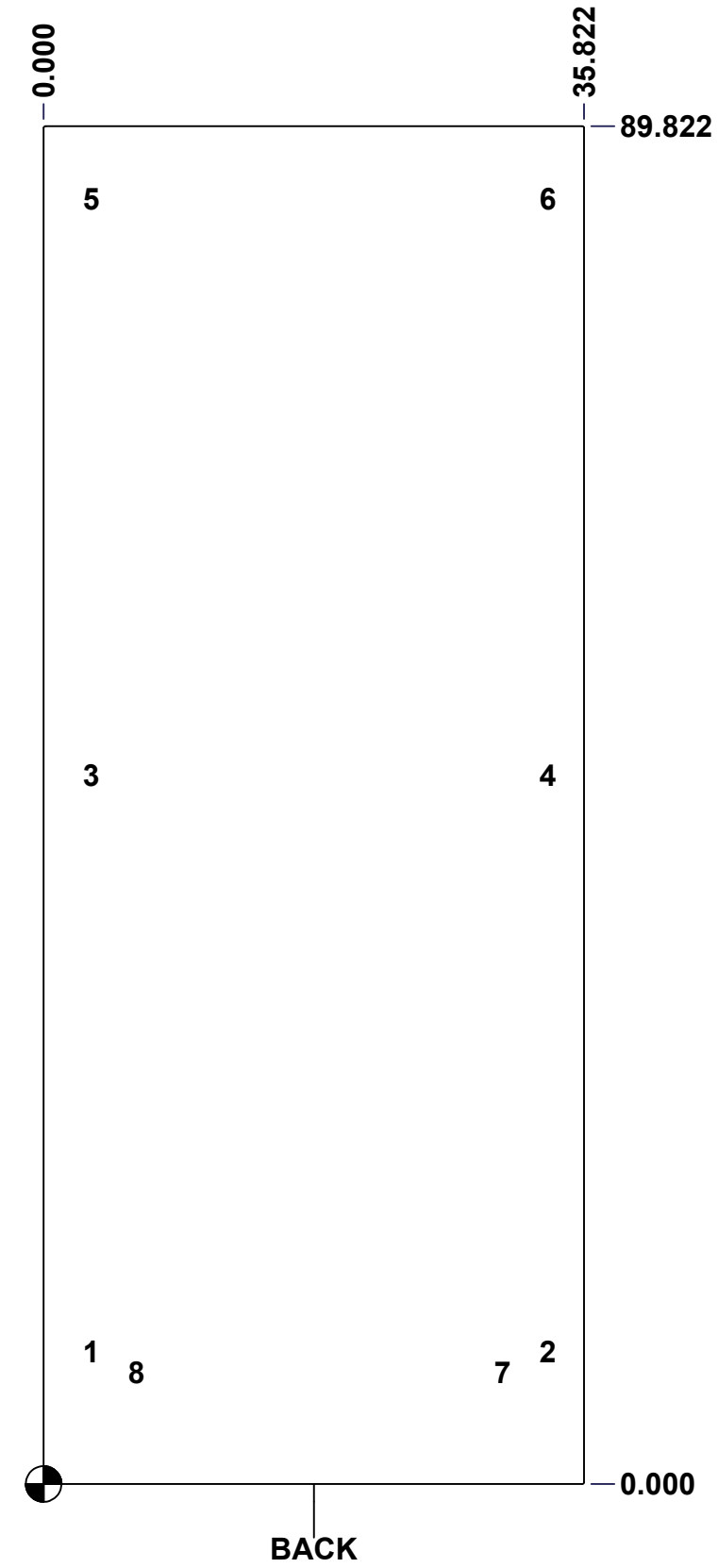

	Description	Status
	9412 90" x 36" x 24" Body	Released
	Part Number Numéro Pièce	Rev.
	9412ST903624B	0
		6
		7

This drawing is confidential and must not be reproduced or used without the consent of EXM

Ce dessin est confidentiel et ne doit pas être reproduit ou utilisé sans le consentement de EXM

No.	Revisions	Date	By/Par

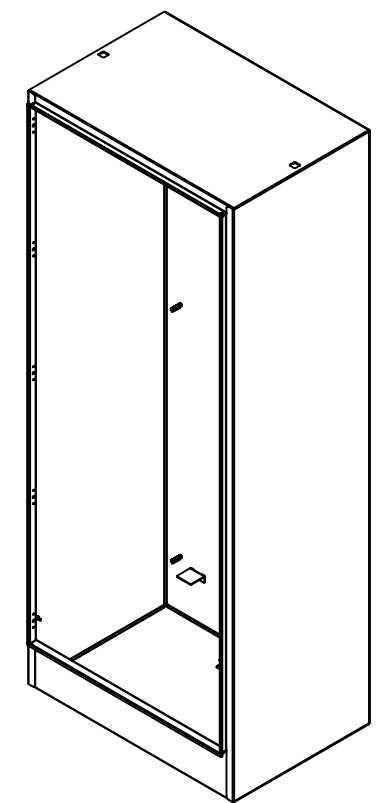

Isometric View

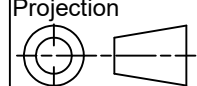

Qty	Part Number	Rev	Description
3	STK-Q-16030	0	Stud M6 x 10mm
3	STK-Q-07220	1	M6 Nylon Insert Lock Nut
1	CR400MS_27.5	0	Commercial Roll Mild Steel (27.5in long)
2	9412ST903624BPA-P	0	9412 Inner Panel Support Angle
1	STK-P-02400S	0	Powder Paint (Asa-61 Grey / Smooth)
6	STK-Q-16100	0	Stud M10 x 40mm
1	9412ST903624BT-P	0	9412 36" x 24" Bottom Part
1	9412ST903624T-P	0	9412 36" x 24" Top Part
1	9412ST903624RS-P	0	9412 90" x 36" Right Part
1	9412ST903624LS-P	0	9412 90" x 36" Left Part
1	9412ST903624B-P	0	9412 90" x 36" Back Part
3	STK-Q-16080	0	Ground Stud M6 x 16mm
Qty	Part Number	Rev	Description
Parts List			

 Tél: (450) 979-4373 Fax: (450) 979-4626 www.exmweb.com		Flatness Aplatissement Max 3.0mm Projection 
Customer Client	Date	Date
Drawn By Dessiné Par	BoxCad: BoxCad	23-Nov-21
Material Matière	12 Ga Cold Rolled A1008 CS Type B (2.5mm)	
Color Couleur	Asa-61 Grey	Finish Fini: Smooth
Description	9412 90" x 36" x 24" Body	
Part Number Numéro Pièce	Rev.	2
9412ST903624B	0	2

This drawing is confidential and must not be reproduced or used without the consent of EXM

Ce dessin est confidentiel et ne doit pas être reproduit ou utilisé sans le consentement de EXM

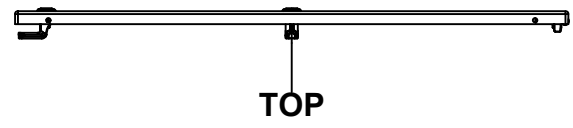

TOP

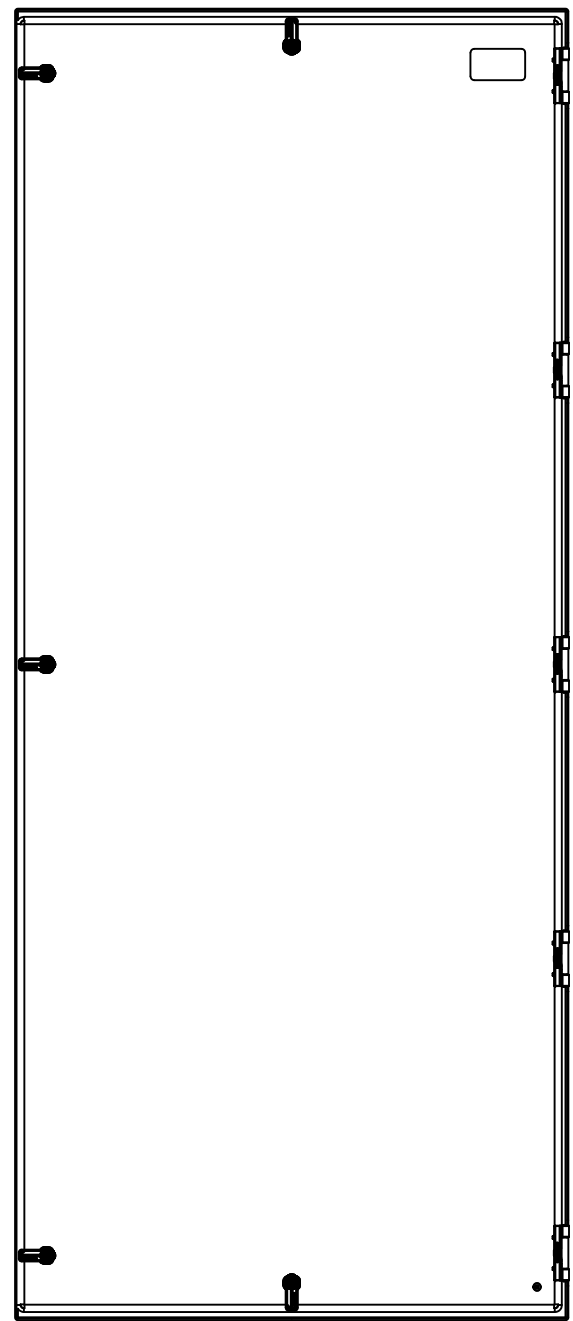

BACK



BOTTOM

0.000
0.835

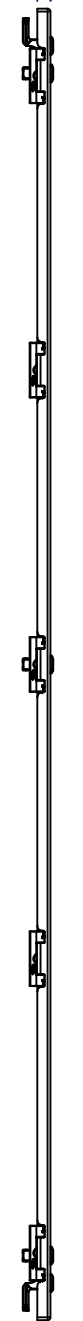

LEFT

0.000

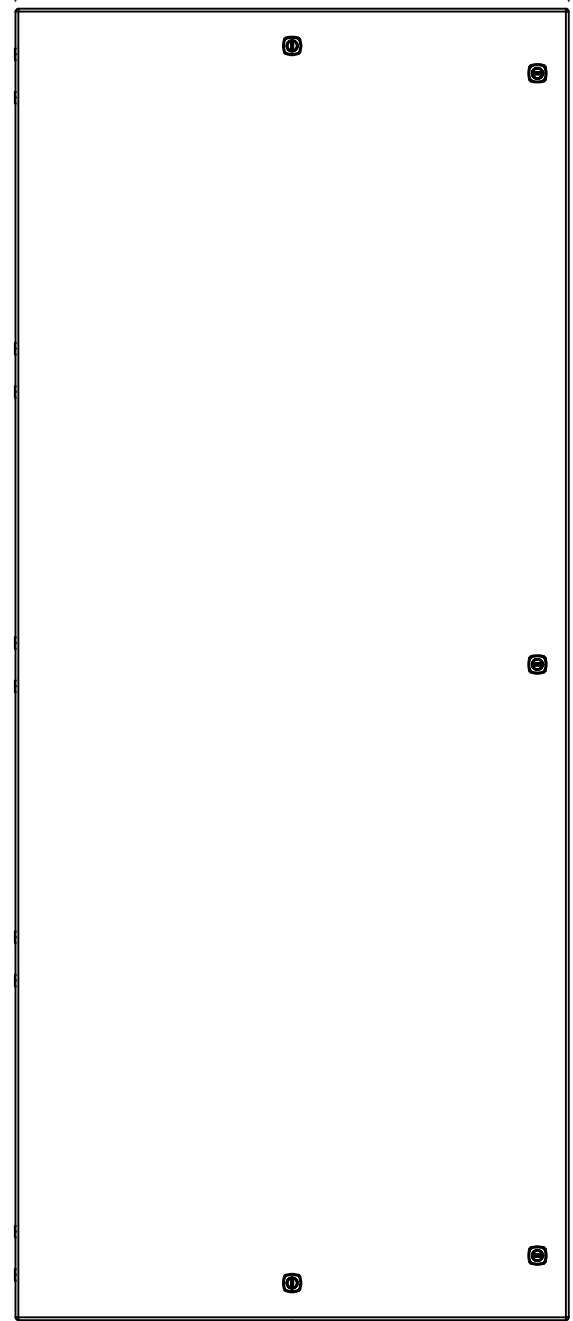

FRONT

35.312

83.549

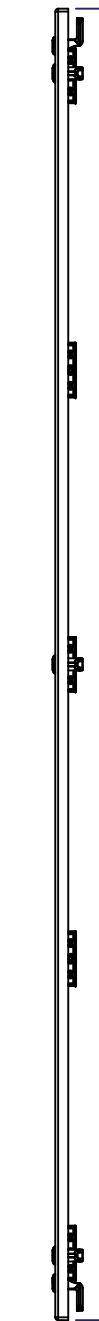

RIGHT

0.000

No.	Revisions	Date	By/Par

Isometric View

<p>Tél: (450) 979-4373 Fax: (450) 979-4626 www.exmweb.com</p>		Flatness Aplatissement	
		Max 3.0mm	
Customer Client		Projection	
Date			
Drawn By Dessiné Par BoxCad: BoxCad		Date 23-Nov-21	
Material Matière 12 Ga Cold Rolled A1008 CS Type B (2.5mm)			
Color Couleur Asa-61 Grey		Finish Fini Smooth	
Description 9412 90" x 36" Cover		Detail Rev.	
Part Number Numéro Pièce 9412ST903624C		Rev. 0	1 3

SEE BILL OF MATERIAL ON LAST PAGE

This drawing is confidential and must not be reproduced or used without the consent of EXM

Ce dessin est confidentiel et ne doit pas être reproduit ou utilisé sans le consentement de EXM

STANDARD FEATURES ARE NOT LISTED IN THIS HOLE TABLE

HOLE TABLE - FRONT VIEW (CUSTOM FEATURE ONLY)

CUT-OUT	XDIM	YDIM	DESCRIPTION
1	2.000	2.118	GND STUD M6 x 16mm (Inside)
2	33.312	79.430	LOCK 889 SCQ4-SL @ 0.0°
3	33.312	41.774	LOCK 889 SCQ4-SL @ 0.0°
4	33.312	4.118	LOCK 889 SCQ4-SL @ 0.0°
5	17.656	81.180	LOCK 889 SCQ4-SL @ 90.0°
6	17.656	2.368	LOCK 889 SCQ4-SL @ 270.0°

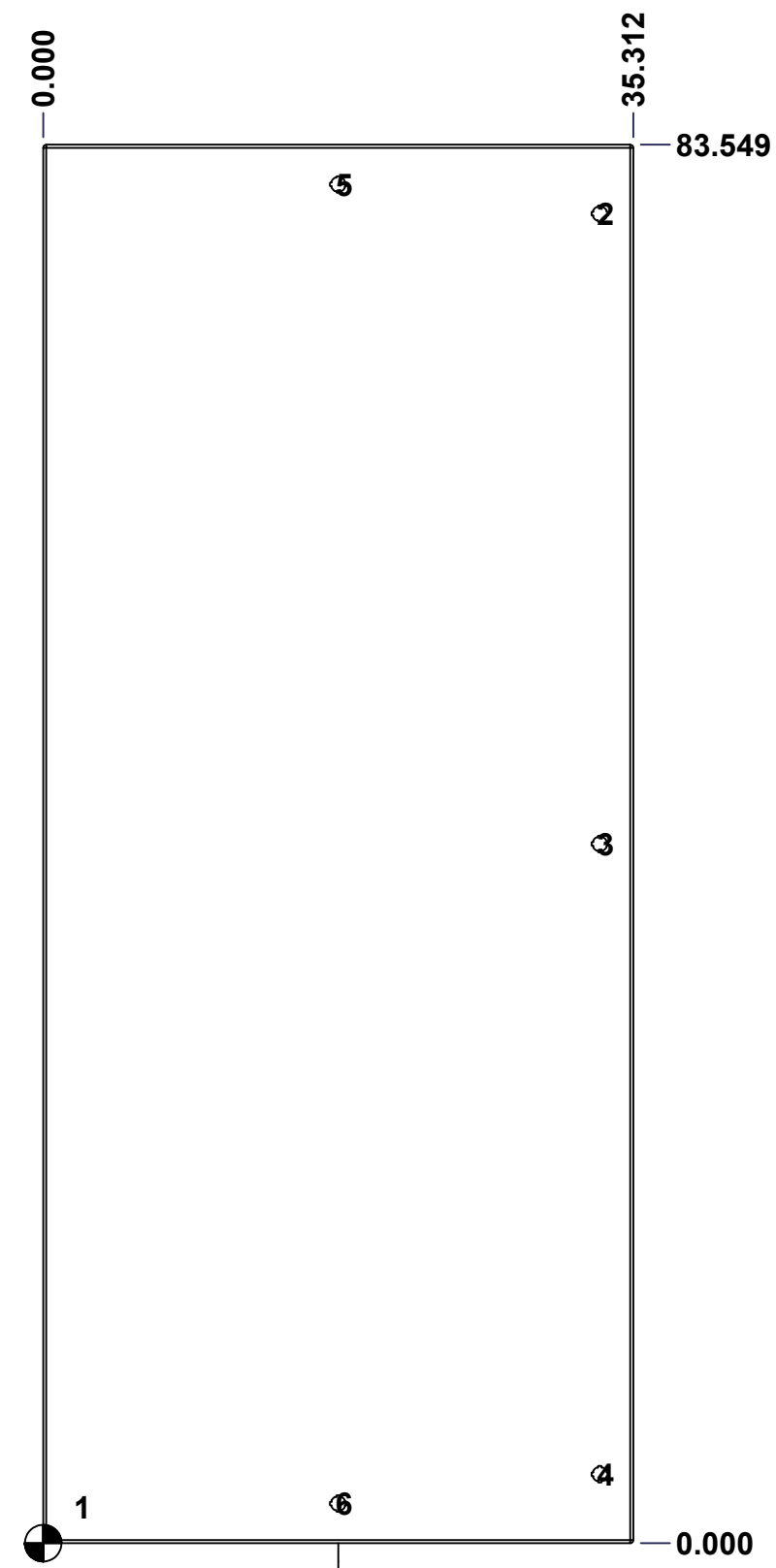

FRONT

	Description	Status	
	9412 90" x 36" Cover	(NULL)	
	Part Number Numéro Pièce	Rev.	
	9412ST903624C	0	2 3

This drawing is confidential and must not be reproduced or used without the consent of EXM

Ce dessin est confidentiel et ne doit pas être reproduit ou utilisé sans le consentement de EXM

No.	Revisions	Date	By/Par

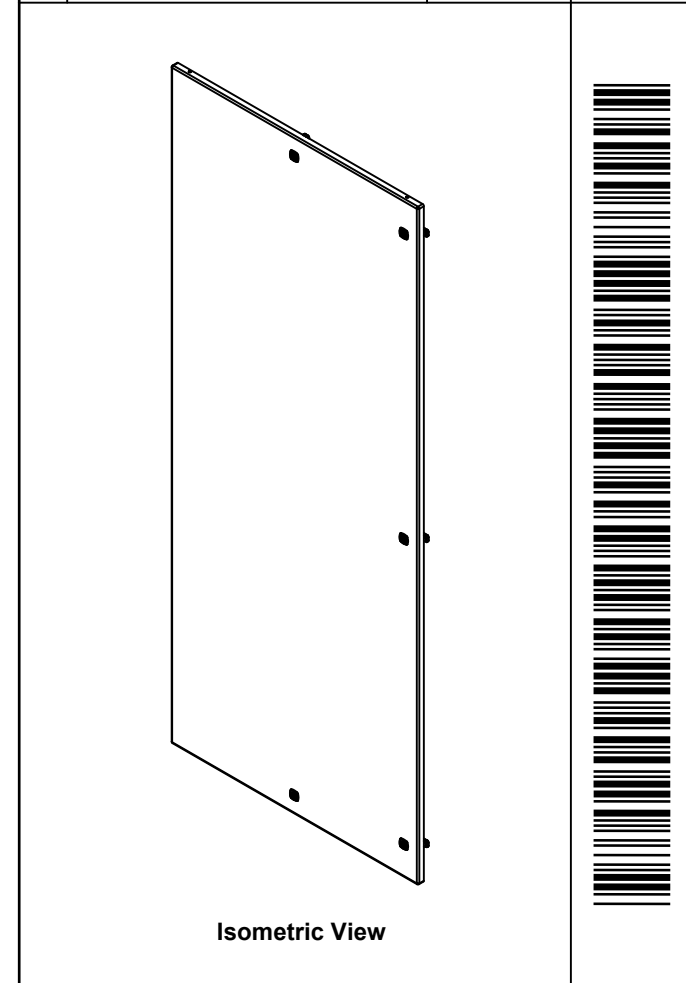

Tél: (450) 979-4373 Fax: (450) 979-4626 www.exmweb.com		Flatness Aplatissement
		Max 3.0mm
Projection		Date
Customer Client		Date 23-Nov-21
Drawn By / Dessiné Par: BoxCad: BoxCad		
Material / Matière: 12 Ga Cold Rolled A1008 CS Type B (2.5mm)		
Color / Couleur: Asa-61 Grey	Finish / Fini: Smooth	
Description: 9412 90" x 36" Cover		Detail Rev.
Part Number / Numéro Pièce: 9412ST903624C		Rev. 3 0

1	STK-Q-16080	0	Ground Stud M6 x 16mm
1	9412ST903624G	0	9412 90" x 36" Cover Gasket
1	STK-P-02400S	0	Powder Paint (Asa-61 Grey / Smooth)
1	STK-S-00100	0	3.5" x 2" Silver Milar Flexcon Sticker
1	9412ST903624C-P	0	9412 90" x 36" Cover Part
5	STK-K-09860	7	Cabinet Hinge with Captive Pins
5	STK-K-12580	0	9412 1/4 Turn Lock
Qty	Part Name	Rev	Description
Parts List			