

This drawing is confidential and must not be reproduced or used without the consent of EXM

Ce dessin est confidentiel et ne doit pas être reproduit ou utilisé sans le consentement de EXM

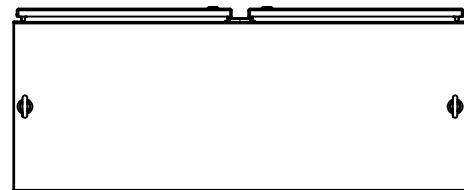

TOP



BACK

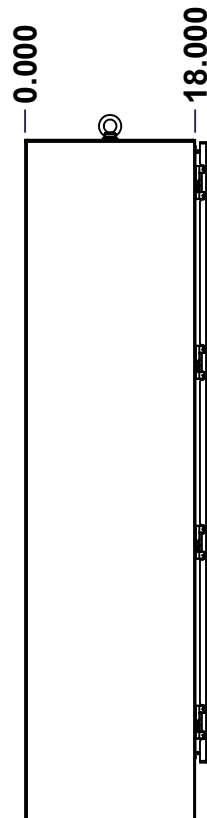

LEFT

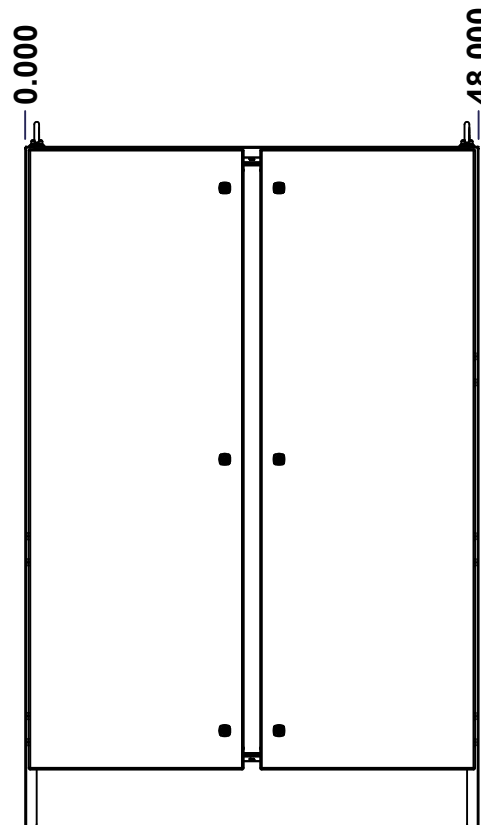

FRONT

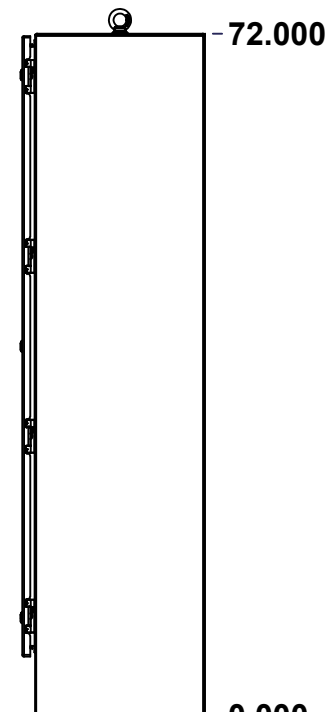

RIGHT

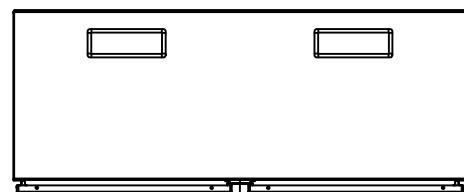

BOTTOM

No.	Revisions	Date	By/Par

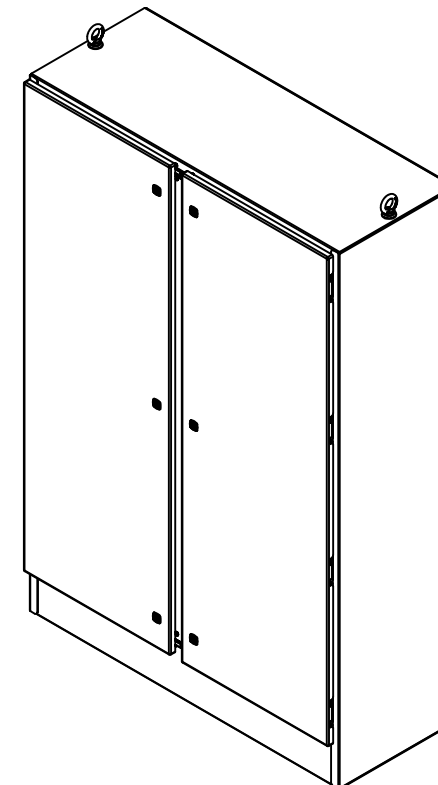

Isometric View



Tél: (450) 979-4373  
 Fax: (450) 979-4626  
[www.exmweb.com](http://www.exmweb.com)

Flatness  
Aplatissement

Max 3.0mm

Projection

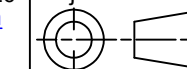

Customer Client	Date
Drawn By / Dessiné Par: BoxCad: BoxCad	Date: 26-Nov-21

Material / Matière: 12 Ga Cold Rolled A1008 CS Type B (2.5mm)

Color / Couleur: Asa-61 Grey      Finish / Fini: Smooth

Description: 9412DD 72" x 48" x 18" Assembly      Detail Rev.

Part Number / Numéro Pièce: <b>9412STDD724818</b>	Rev. 1
SEE BILL OF MATERIAL ON LAST PAGE	Rev. 0

2

This drawing is confidential and must not be reproduced or used without the consent of EXM

Ce dessin est confidentiel et ne doit pas être reproduit ou utilisé sans le consentement de EXM

NOTE	
ITEM	DESCRIPTION
1	NEMA 4/12 Enclosure
2	C/W Standard ground studs on box and cover
3	W/O Standard door stiffener
4	W/O Inner panel
5	C/W Standard inner panel mounting studs
6	C/W Eyebolts
7	C/W Struts installed (Included)

No.	Revisions	Date	By/Par

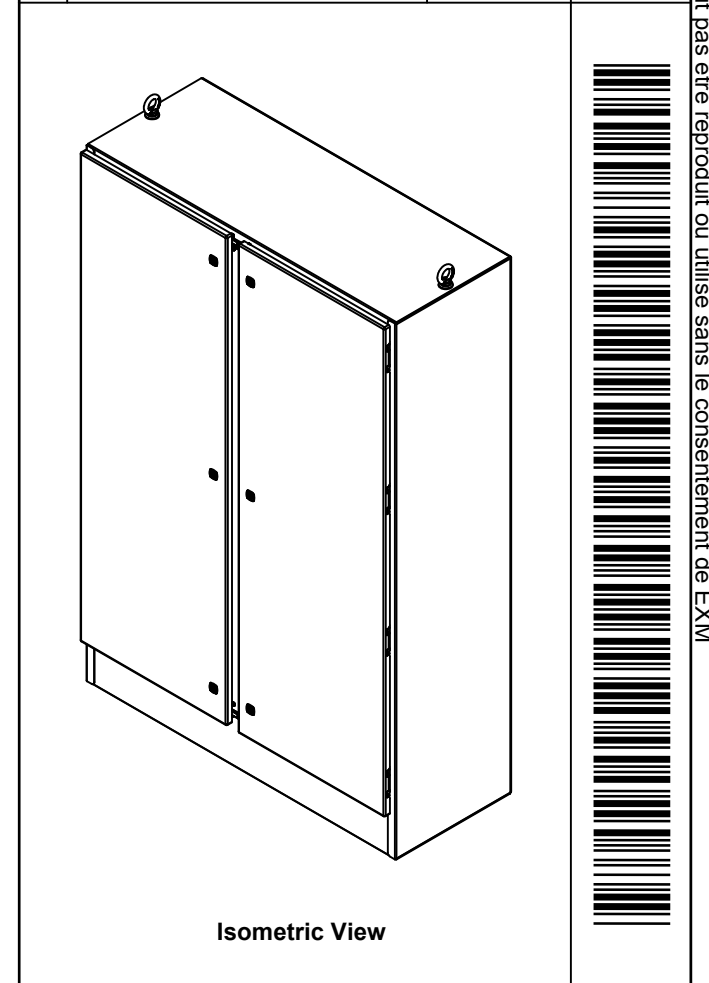

PACKING		
ITEM	QTY	DESCRIPTION
Cardboard sleeve	2	Top and Bottom
Cardboard strip	2	Between back of enclosure and inner panel
Plastic bag	1	To protect cover surface and inside gasket
Cardboard corner	4	To reinforced for the plastic strap tightening
Plastic strap - Black	2	To Squeeze 2 cardboard sleeve together
Packaging label	3	White label with PN
Plastic strap- Green	2	To secure the enclosure to the wood pallet
Wood Pallet	1	2" deeper and 3" larger than enclosure size

1	880INTI	2	880 INTI - Interlock Post Kit
1	880EB14	2	Eye Bolt M14 (Pack of 2)
1	9412STDD724818FD	0	9412DD 72" x 48" Master Door
1	9412STDD724818LD	0	9412DD 72" x 48" Slave Door
1	9412STDD724818B	0	9412DD 72" x 48" x 18" Body
2	9412STDD724818GP	0	9412DD Gland Plate
8	STK-Q-04050-10	8	M6 x 10mm Hexagon Socket Head Machine Screw with Nyseal
Qty	Part Number	Rev	Description
Parts List			

		Tél: (450) 979-4373 Fax: (450) 979-4626 <a href="http://www.exmweb.com">www.exmweb.com</a>		Flatness Aplatissement Max 3.0mm Projection 
Customer Client		Date		
Drawn By / Dessiné Par: BoxCad: BoxCad		Date: 26-Nov-21		
Material / Matière: 12 Ga Cold Rolled A1008 CS Type B (2.5mm)		Color / Couleur: Asa-61 Grey		
Description: 9412DD 72" x 48" x 18" Assembly		Finish / Fini: Smooth		
Part Number / Numéro Pièce: <b>9412STDD724818</b>		Detail Rev. / Rev.: 0		

This drawing is confidential and must not be reproduced or used without the consent of EXM

Ce dessin est confidentiel et ne doit pas être reproduit ou utilisé sans le consentement de EXM

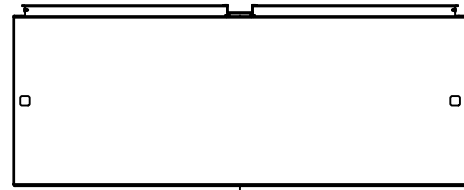

TOP

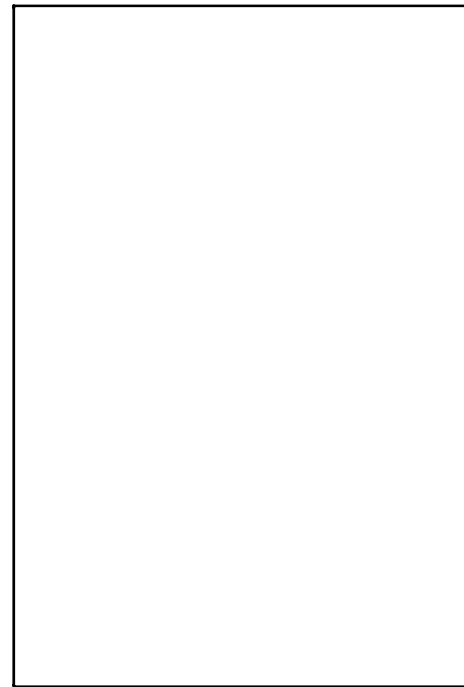

BACK

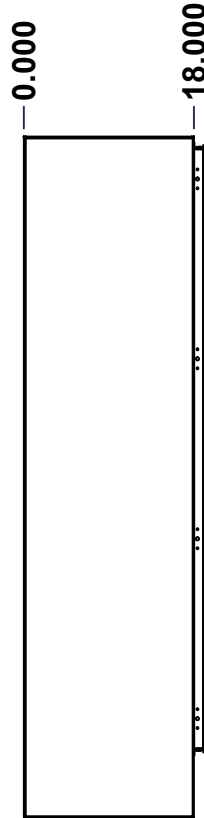

LEFT

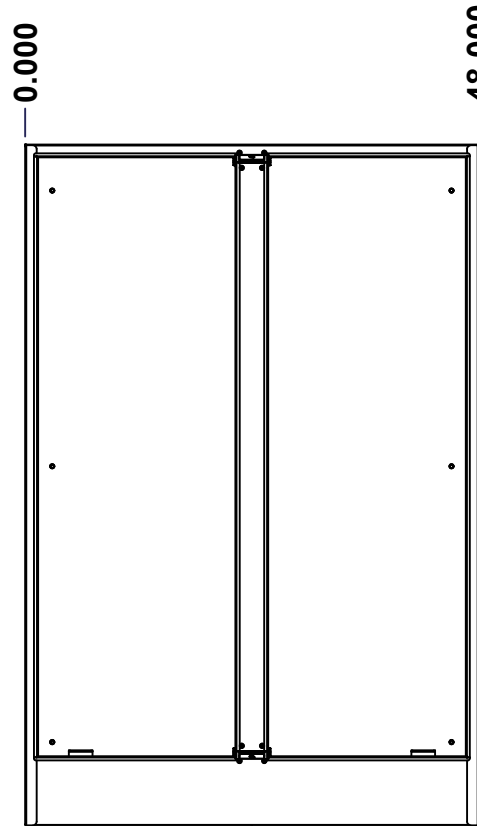

FRONT

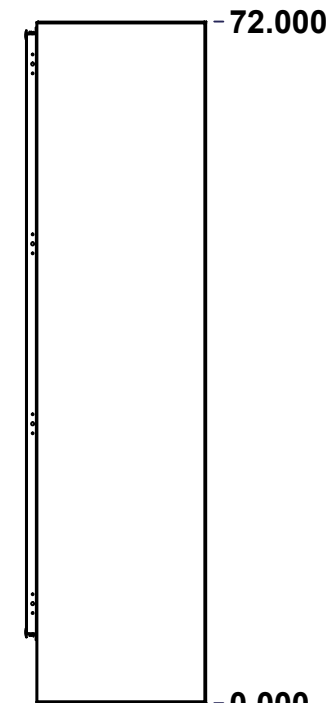

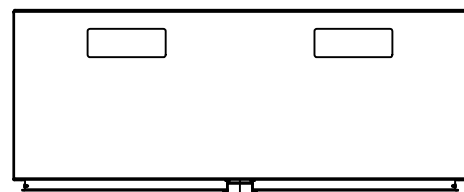

RIGHT

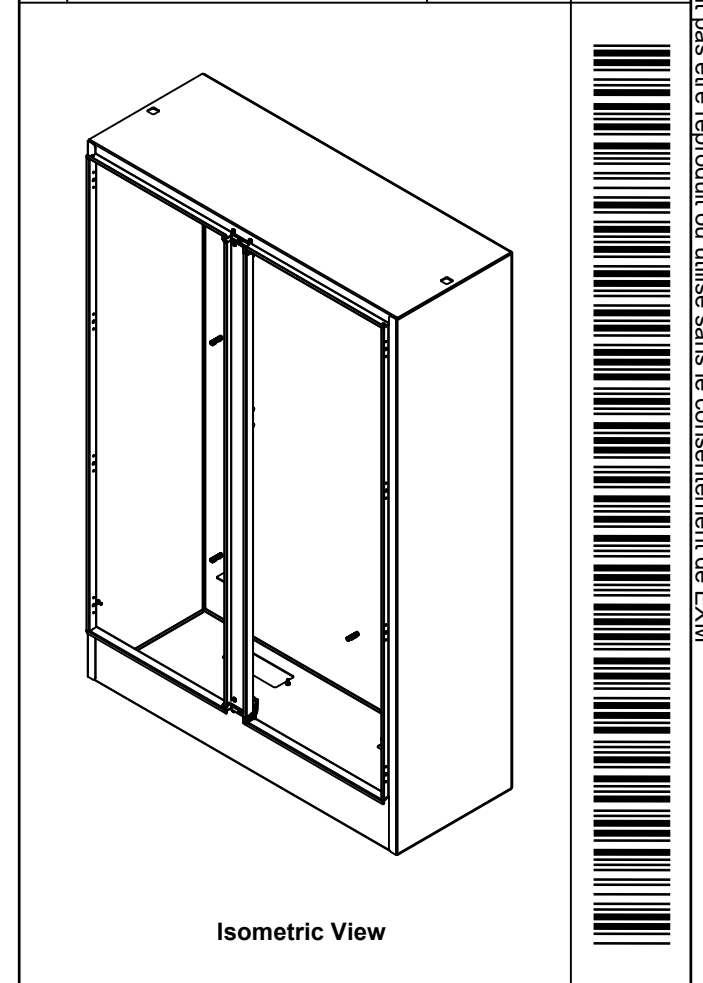

BOTTOM

No.	Revisions	Date	By/Par

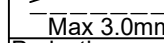
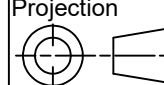

 Tél: (450) 979-4373 Fax: (450) 979-4626 <a href="http://www.exmweb.com">www.exmweb.com</a>		Flatness Aplatissement  Max 3.0mm Projection 
Customer Client	Date	
Drawn By Dessiné Par	BoxCad: BoxCad	Date 26-Nov-21
Material Matière	12 Ga Cold Rolled A1008 CS Type B (2.5mm)	
Color Couleur	Asa-61 Grey	Finish Fini Smooth
Description	Detail Rev.	
9412DD 72" x 48" x 18" Body		
Part Number Numéro Pièce	Rev.	1
<b>9412STDD724818B</b>	<b>0</b>	2

SEE BILL OF MATERIAL ON LAST PAGE

This drawing is confidential and must not be reproduced or used without the consent of EXM

Ce dessin est confidentiel et ne doit pas être reproduit ou utilisé sans le consentement de EXM

**STANDARD FEATURES ARE NOT LISTED IN THIS HOLE TABLE**

**HOLE TABLE - TOP VIEW (CUSTOM FEATURE ONLY)**

CUT-OUT	XDIM	YDIM	DESCRIPTION
1	35.911	13.911	Struts CR400 17.500" (Inside)
2	11.911	13.911	Struts CR400 17.500" (Inside)
3	35.911	13.911	STUDS M6 x 10mm (Inside)
4	30.161	13.911	STUDS M6 x 10mm (Inside)
5	41.661	13.911	STUDS M6 x 10mm (Inside)
6	11.911	13.911	STUDS M6 x 10mm (Inside)
7	6.161	13.911	STUDS M6 x 10mm (Inside)
8	17.661	13.911	STUDS M6 x 10mm (Inside)

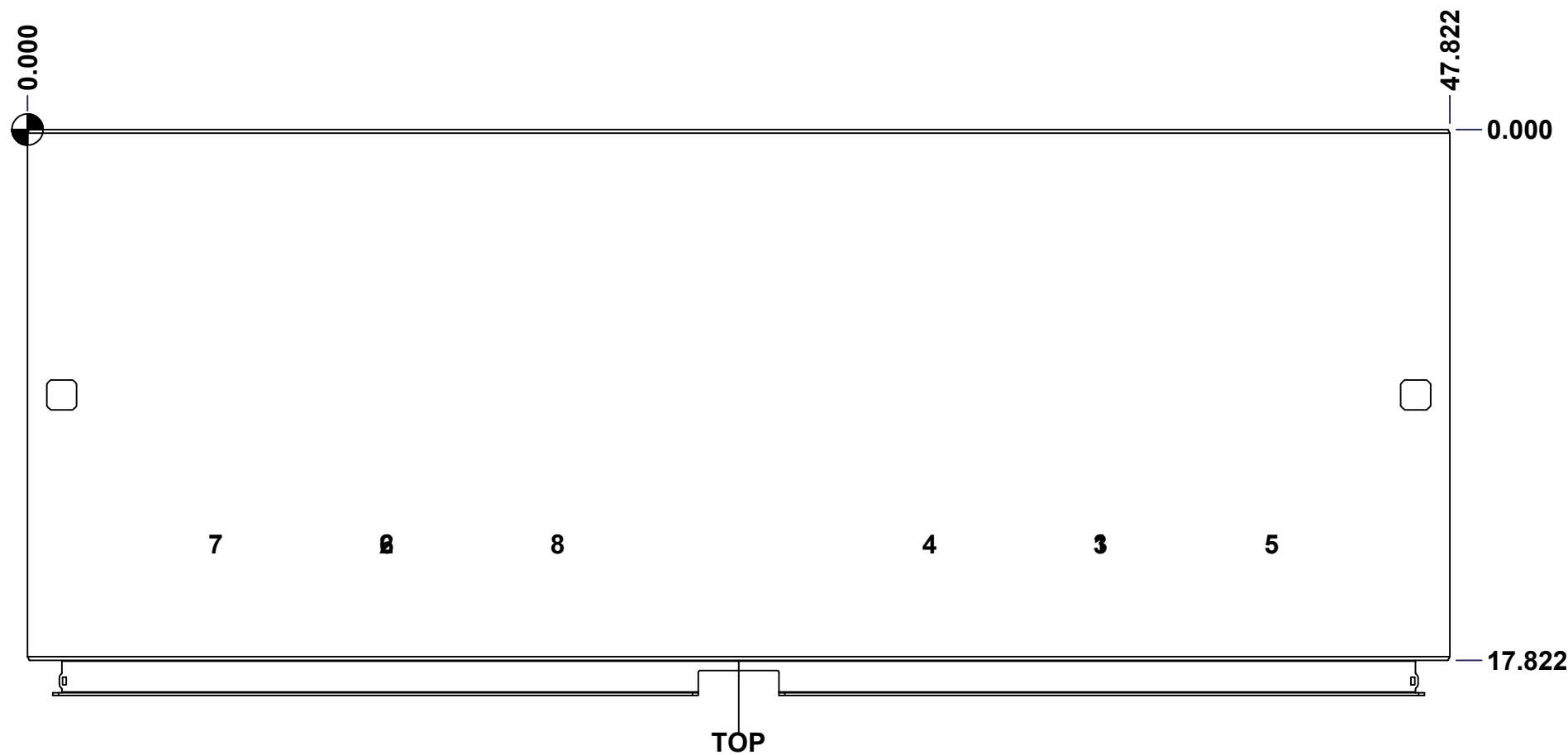

	Description	Status	
	9412DD 72" x 48" x 18" Body	Released	
	Part Number Numéro Pièce	Rev.	
	<b>9412STDD724818B</b>	<b>0</b>	2 / 7

This drawing is confidential and must not be reproduced or used without the consent of EXM

Ce dessin est confidentiel et ne doit pas être reproduit ou utilisé sans le consentement de EXM

<b>STANDARD FEATURES ARE NOT LISTED IN THIS HOLE TABLE</b>			
<b>HOLE TABLE - RIGHT VIEW (CUSTOM FEATURE ONLY)</b>			
CUT-OUT	XDIM	YDIM	DESCRIPTION
1	16.411	9.286	GND STUD M6 x 16mm (Inside)

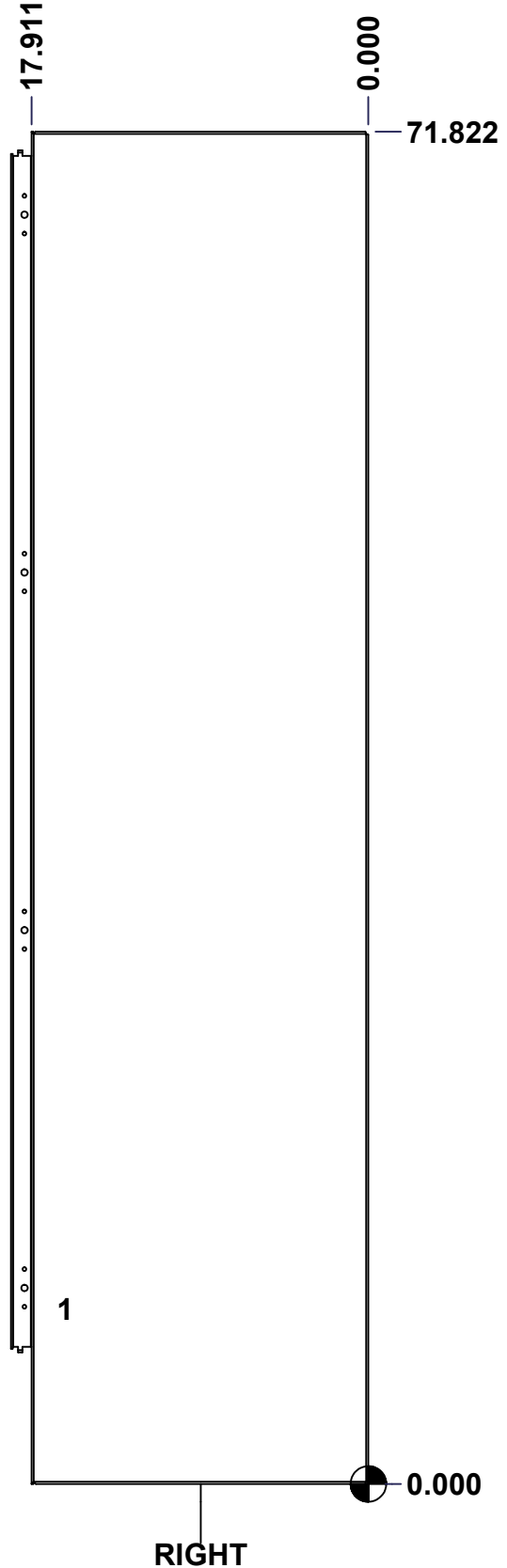

	Description	Status	
	9412DD 72" x 48" x 18" Body	Released	
	Part Number Numéro Pièce	Rev.	
	<b>9412STDD724818B</b>	<b>0</b>	3 / 7

This drawing is confidential and must not be reproduced or used without the consent of EXM

Ce dessin est confidentiel et ne doit pas être reproduit ou utilisé sans le consentement de EXM

STANDARD FEATURES ARE NOT LISTED IN THIS HOLE TABLE			
HOLE TABLE - BOTTOM VIEW (CUSTOM FEATURE ONLY)			
CUT-OUT	XDIM	YDIM	DESCRIPTION
1	7.286	3.411	GP STUD M6 x 16mm (Inside)
2	16.536	3.411	GP STUD M6 x 16mm (Inside)
3	31.286	3.411	GP STUD M6 x 16mm (Inside)
4	40.536	3.411	GP STUD M6 x 16mm (Inside)

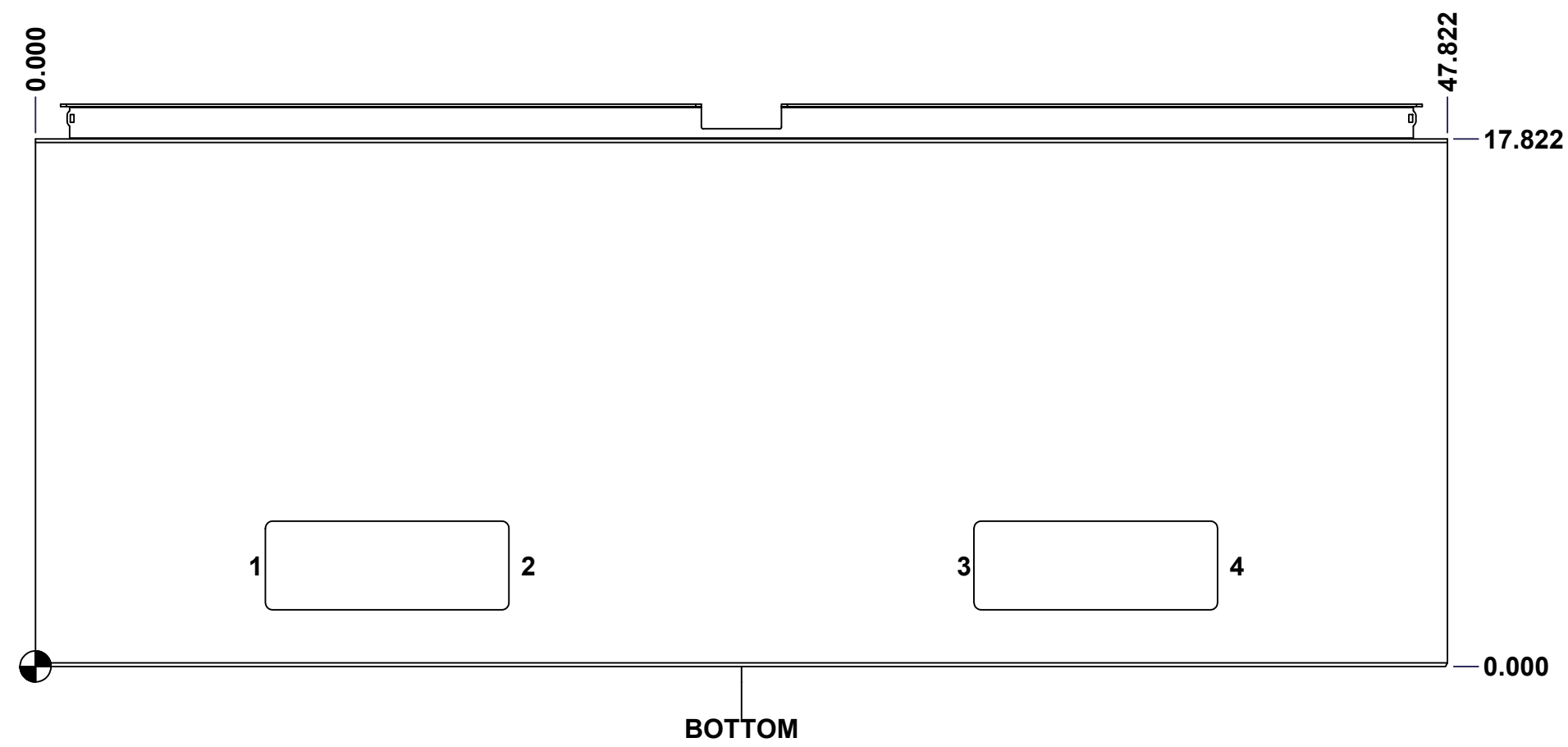

	Description	Status	
	9412DD 72" x 48" x 18" Body	Released	
	Part Number Numéro Pièce	Rev.	
	<b>9412STDD724818B</b>	<b>0</b>	4 / 7

This drawing is confidential and must not be reproduced or used without the consent of EXM

Ce dessin est confidentiel et ne doit pas être reproduit ou utilisé sans le consentement de EXM

<b>STANDARD FEATURES ARE NOT LISTED IN THIS HOLE TABLE</b>			
<b>HOLE TABLE - LEFT VIEW (CUSTOM FEATURE ONLY)</b>			
CUT-OUT	XDIM	YDIM	DESCRIPTION
1	16.411	9.286	GND STUD M6 x 16mm (Inside)

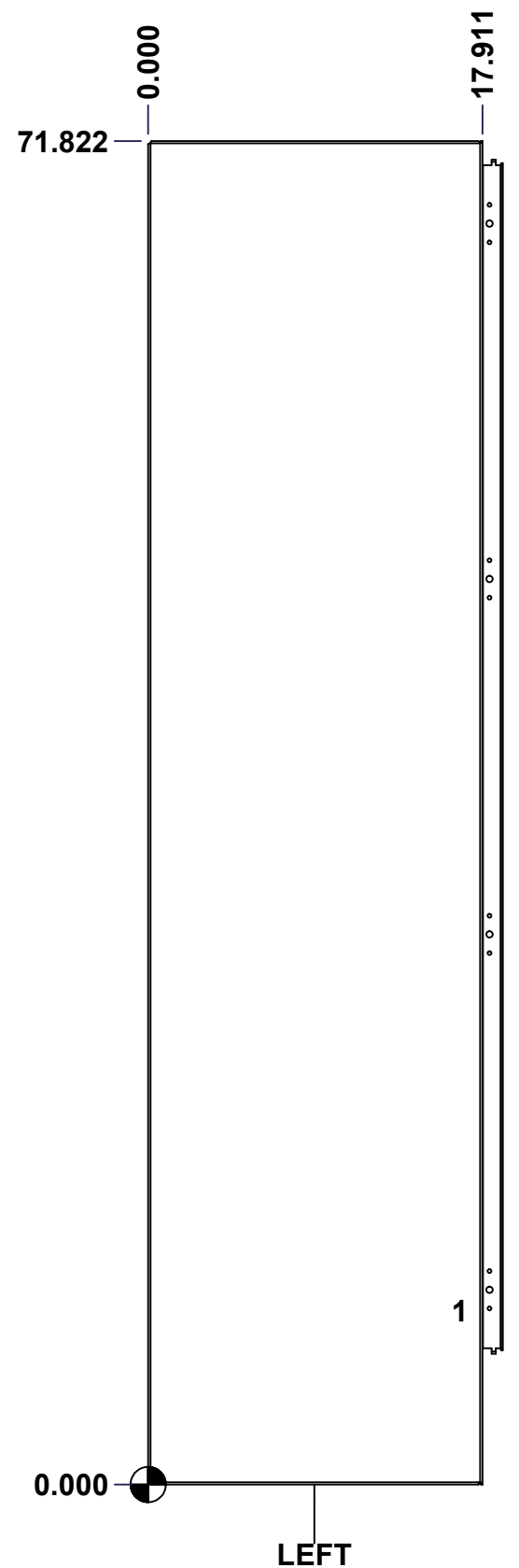

	Description	Status
	9412DD 72" x 48" x 18" Body	Released
	Part Number Numéro Pièce	Rev.
	<b>9412STDD724818B</b>	<b>0</b>
		5 / 7

This drawing is confidential and must not be reproduced or used without the consent of EXM

Ce dessin est confidentiel et ne doit pas être reproduit ou utilisé sans le consentement de EXM

**STANDARD FEATURES ARE NOT LISTED IN THIS HOLE TABLE**

**HOLE TABLE - BACK VIEW (CUSTOM FEATURE ONLY)**

CUT-OUT	XDIM	YDIM	DESCRIPTION
1	2.786	8.786	IP STUD M10 x 40mm (Inside)
2	45.036	8.786	IP STUD M10 x 40mm (Inside)
3	2.786	37.911	IP STUD M10 x 40mm (Inside)
4	45.036	37.911	IP STUD M10 x 40mm (Inside)
5	2.786	67.036	IP STUD M10 x 40mm (Inside)
6	45.036	67.036	IP STUD M10 x 40mm (Inside)
7	23.911	8.786	IP STUD M10 x 40mm (Inside)
8	23.911	67.036	IP STUD M10 x 40mm (Inside)
-----	-----	-----	-----
9	42.036	7.411	IP SUPPORT ANGLE (Inside)
10	5.786	7.411	IP SUPPORT ANGLE (Inside)

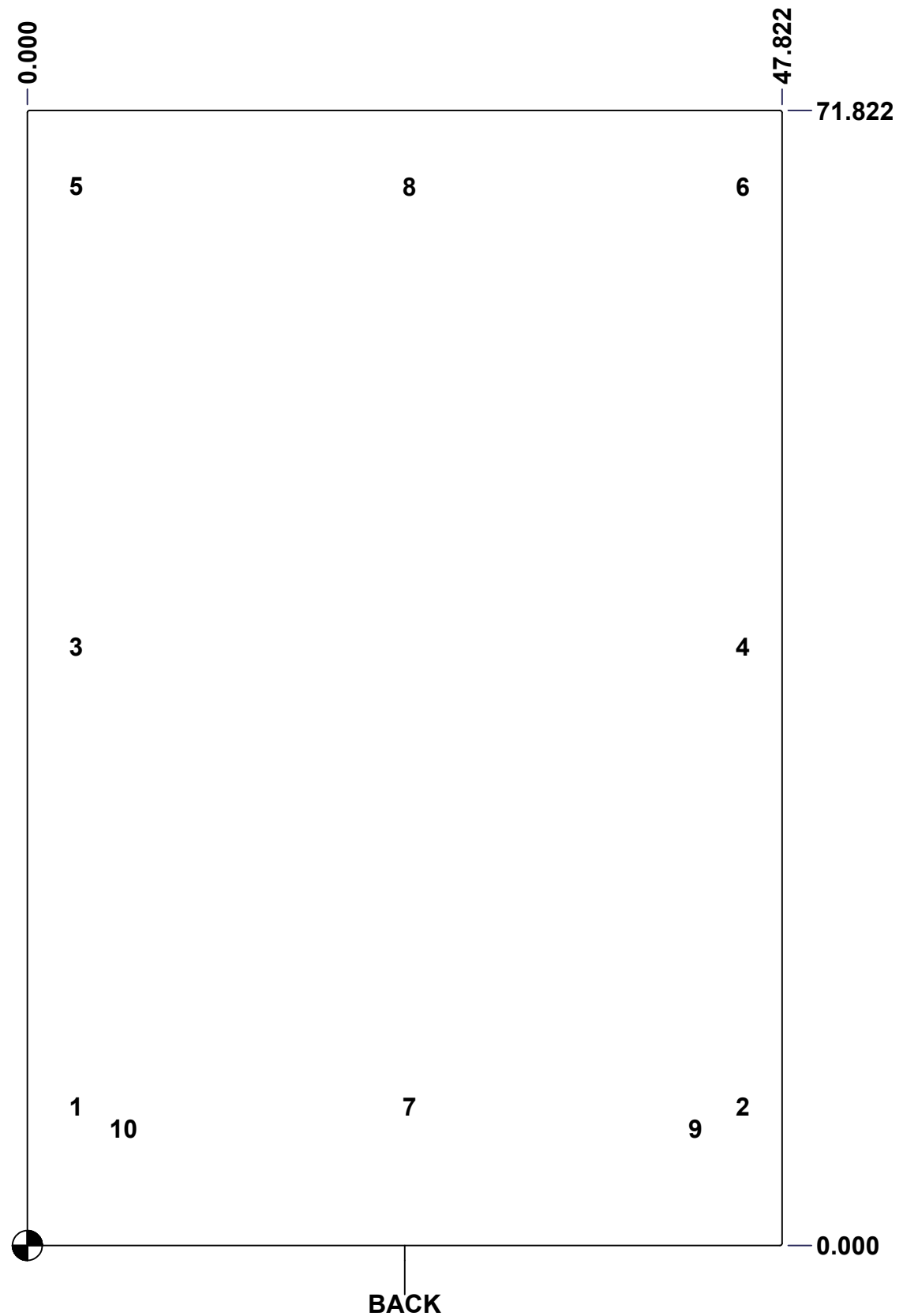

	Description	Status
	9412DD 72" x 48" x 18" Body	Released
	Part Number Numéro Pièce	Rev.
	<b>9412STDD724818B</b>	<b>0</b>
		6
		7

This drawing is confidential and must not be reproduced or used without the consent of EXM

Ce dessin est confidentiel et ne doit pas être reproduit ou utilisé sans le consentement de EXM

STANDARD FEATURES ARE NOT LISTED IN THIS HOLE TABLE			
HOLE TABLE - CENTER VIEW (CUSTOM FEATURE ONLY)			
CUT-OUT	XDIM	YDIM	DESCRIPTION
1	0.748	38.210	INTERLOCK STUD M6 x 16mm (Inside)
2	0.748	40.336	INTERLOCK STUD M6 x 16mm (Inside)
3	2.717	38.210	INTERLOCK STUD M6 x 16mm (Inside)
4	2.717	40.336	INTERLOCK STUD M6 x 16mm (Inside)

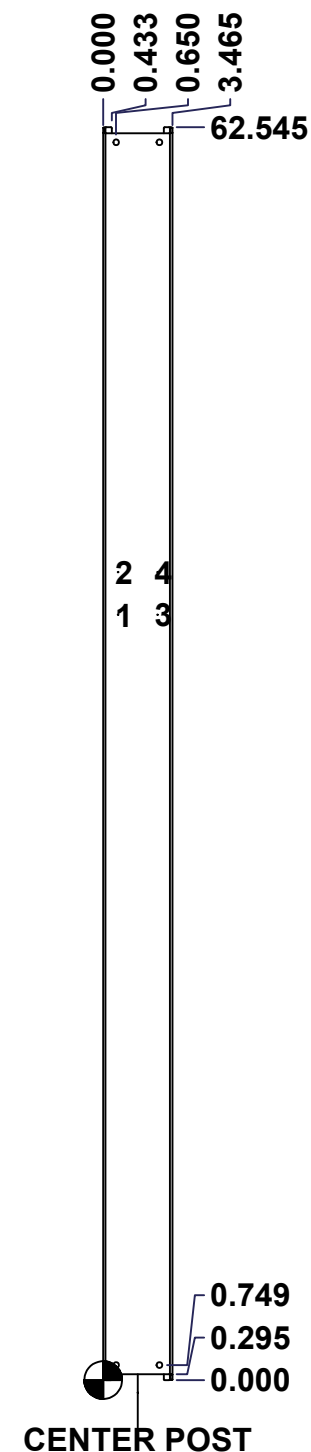

	Description	Status	
	9412DD 72" x 48" x 18" Body	Released	
	Part Number Numéro Pièce	Rev.	
	<b>9412STDD724818B</b>	<b>0</b>	6 7

This drawing is confidential and must not be reproduced or used without the consent of EXM

Ce dessin est confidentiel et ne doit pas être reproduit ou utilisé sans le consentement de EXM

No.	Revisions	Date	By/Par

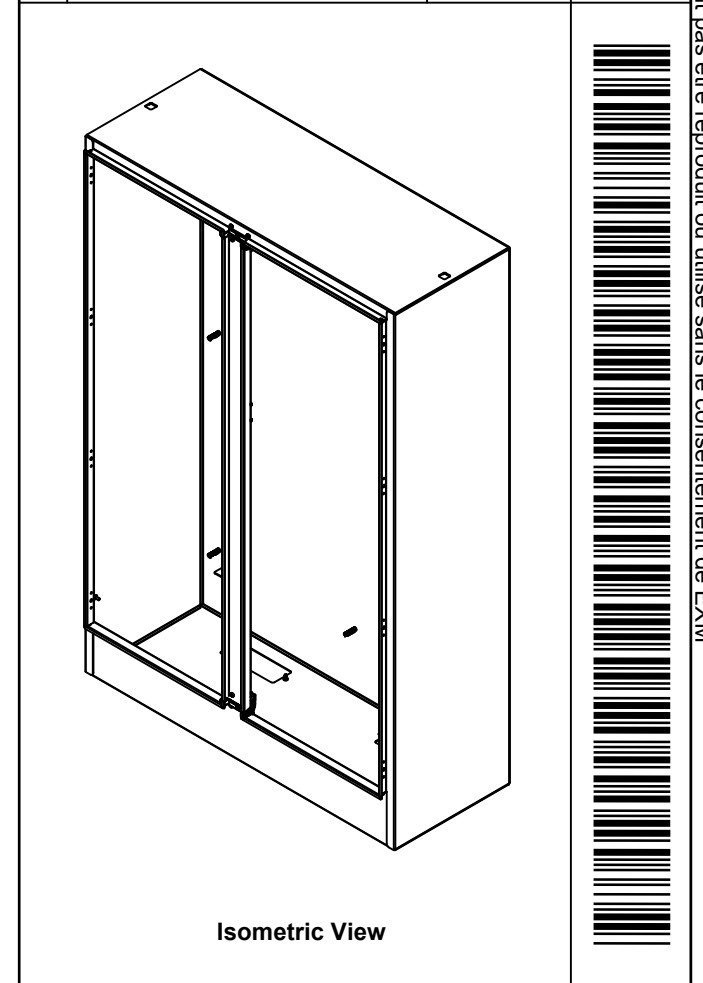

6	STK-Q-16030	0	Stud M6 x 10mm
6	STK-Q-07220	1	M6 Nylon Insert Lock Nut
2	9412STDD724818BPA-P	0	9412DD Inner Panel Support Angle
1	STK-P-02400S	0	Powder Paint (Asa-61 Grey / Smooth)
4	STK-Q-16055	1	M6 x 18mm Stud (No Paint Cap Required)
1	STK-A-75454	3	Center Post - Sealing Block with Latch Assembly (Large)
1	9412STDD724818CP-P	0	9412DD 72" Center Post Part
8	STK-Q-16100	0	Stud M10 x 40mm
1	9412STDD724818BT-P	0	9412DD 48" x 18" Bottom Part
1	9412STDD724818T-P	0	9412DD 48" x 18" Top Part
1	9412STDD724818RS-P	0	9412DD 72" x 48" Right Part
1	9412STDD724818LS-P	0	9412DD 72" x 48" Left Part
1	9412STDD724818B-P	0	9412DD 72" x 48" Back Part
2	CR400MS_17.5	0	Commercial Roll Mild Steel (17.5in long)
6	STK-Q-16080	0	Ground Stud M6 x 16mm
Qty	Part Number	Rev	Description
Parts List			

	Tél: (450) 979-4373 Fax: (450) 979-4626 <a href="http://www.exmweb.com">www.exmweb.com</a>	Flatness	Aplatissement	
		Max 3.0mm		Projection
Customer	Client	Date		
Drawn By	BoxCad: BoxCad	Date	26-Nov-21	
Material	12 Ga Cold Rolled A1008 CS Type B (2.5mm)			
Color	Asa-61 Grey	Finish	Smooth	
Description	9412DD 72" x 48" x 18" Body		Detail Rev.	
Part Number	9412STDD724818B		Rev.	2
Numéro Pièce	9412STDD724818B		0	2

This drawing is confidential and must not be reproduced or used without the consent of EXM

Ce dessin est confidentiel et ne doit pas être reproduit ou utilisé sans le consentement de EXM



TOP

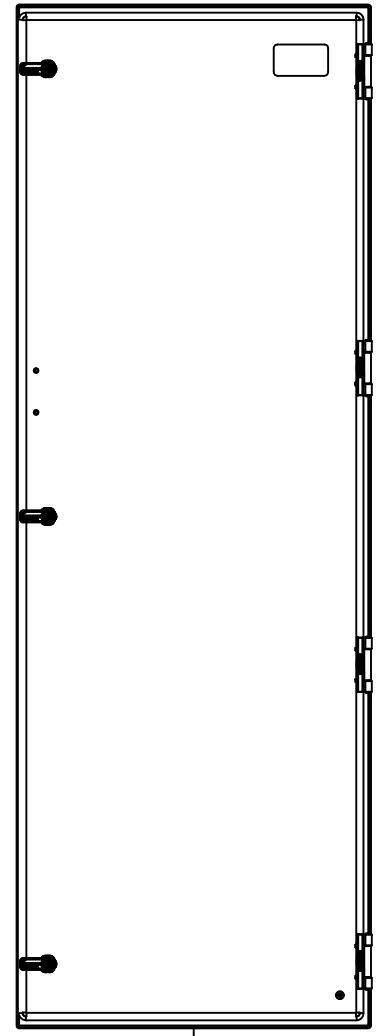

BACK

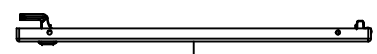

BOTTOM

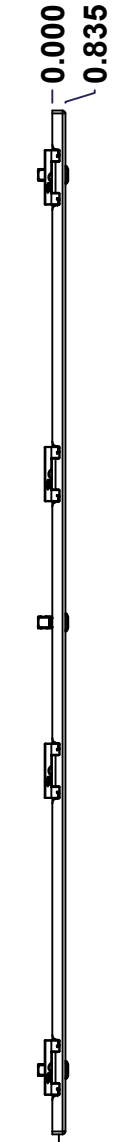

LEFT

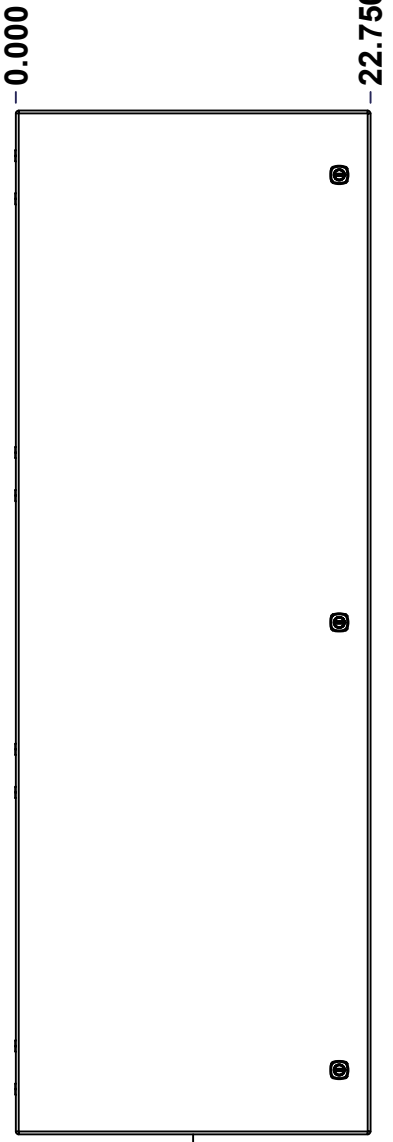

FRONT

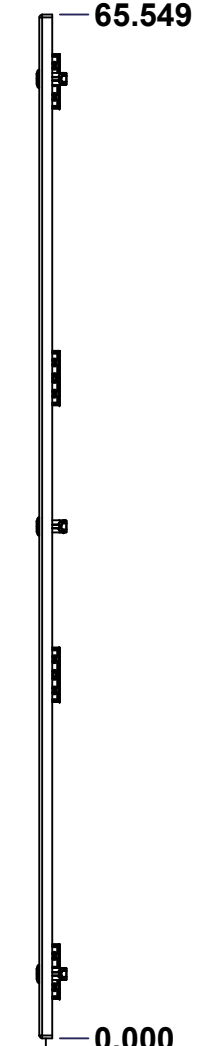

RIGHT

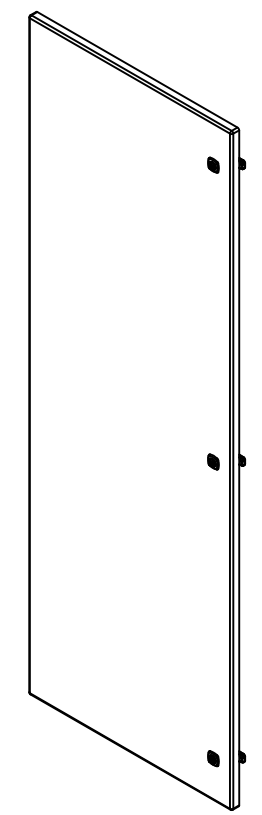

Isometric View

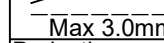
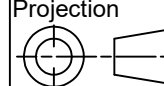

No.	Revisions	Date	By/Par

 Tél: (450) 979-4373 Fax: (450) 979-4626 <a href="http://www.exmweb.com">www.exmweb.com</a>		Flatness Aplatissement  Max 3.0mm Projection 
Customer Client	Date	
Drawn By Dessiné Par	BoxCad: BoxCad	Date 26-Nov-21
Material Matière	12 Ga Cold Rolled A1008 CS Type B (2.5mm)	
Color Couleur	Asa-61 Grey	Finish Fin Smooth
Description	Detail Rev.	
9412DD 72" x 48" Slave Door		
Part Number Numéro Pièce	Rev. 0	1 / 3
9412STDD724818LD		

SEE BILL OF MATERIAL ON LAST PAGE

This drawing is confidential and must not be reproduced or used without the consent of EXM

Ce dessin est confidentiel et ne doit pas être reproduit ou utilisé sans le consentement de EXM

**STANDARD FEATURES ARE NOT LISTED IN THIS HOLE TABLE**

**HOLE TABLE - FRONT VIEW (CUSTOM FEATURE ONLY)**

CUT-OUT	XDIM	YDIM	DESCRIPTION
1	2.000	2.118	GND STUD M6 x 16mm (Inside)
2	20.750	4.118	LOCK 889 SCQ4-SL @ 0.0°
3	20.750	61.430	LOCK 889 SCQ4-SL @ 0.0°
4	20.750	32.774	LOCK 889 SCQ4-SL @ 0.0°
5	21.489	39.435	STUDS M6 x 18mm (Inside)
6	21.489	42.113	STUDS M6 x 18mm (Inside)

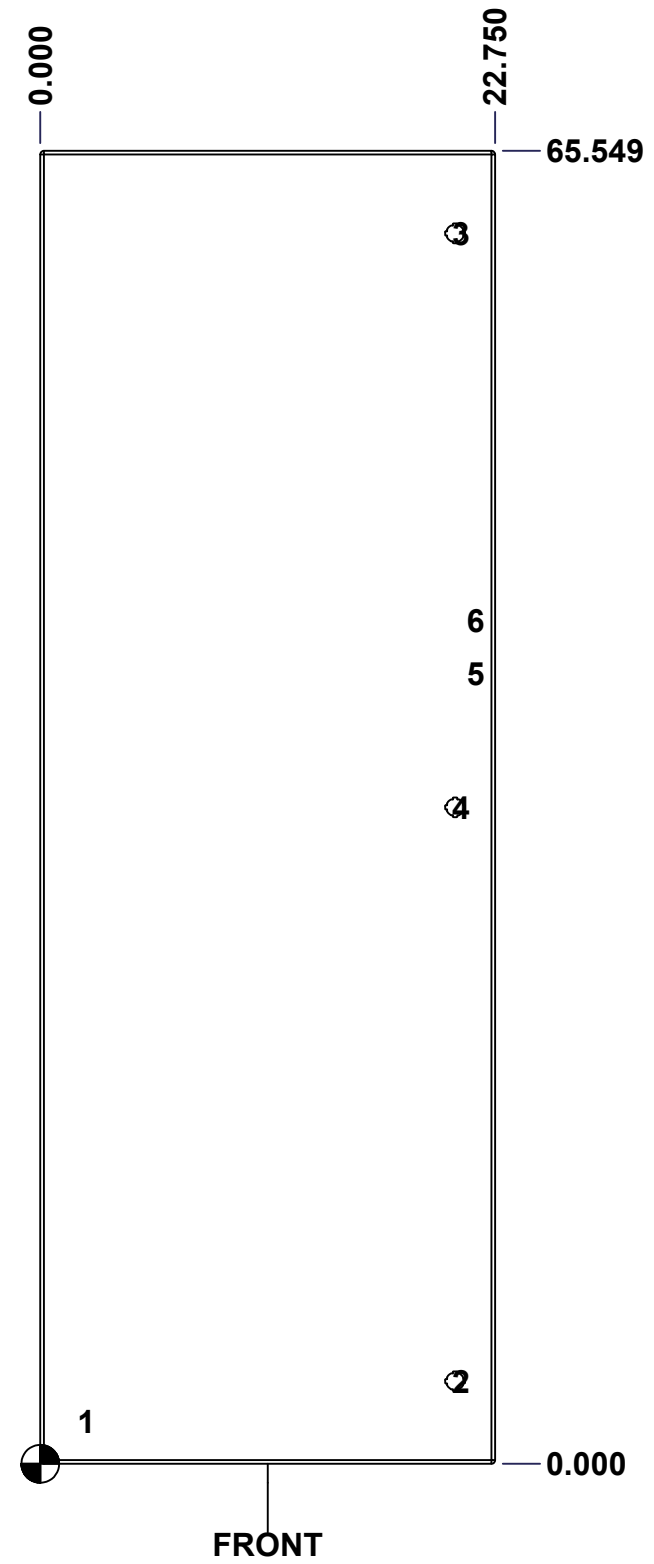

	Description	Status	
	9412DD 72" x 48" Slave Door	(NULL)	
	Part Number Numéro Pièce	Rev.	
	<b>9412STDD724818LD</b>	<b>0</b>	2 / 3

This drawing is confidential and must not be reproduced or used without the consent of EXM

Ce dessin est confidentiel et ne doit pas être reproduit ou utilisé sans le consentement de EXM

No.	Revisions	Date	By/Par

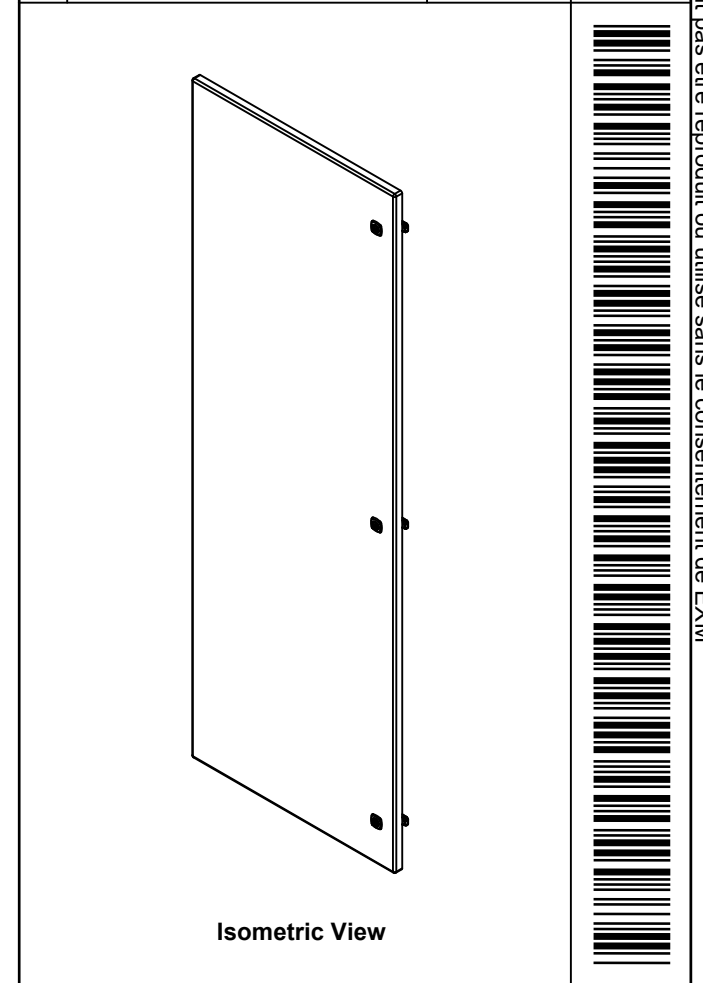

Tél: (450) 979-4373 Fax: (450) 979-4626 <a href="http://www.exmweb.com">www.exmweb.com</a>		Flatness Aplatissement	
		Max 3.0mm Projection	
Customer Client		Date	
Drawn By Dessiné Par BoxCad: BoxCad		Date 26-Nov-21	
Material Matière 12 Ga Cold Rolled A1008 CS Type B (2.5mm)			
Color Couleur Asa-61 Grey		Finish Fini Smooth	
Description 9412DD 72" x 48" Slave Door			Detail Rev.
Part Number Numéro Pièce		Rev.	3
<b>9412STDD724818LD</b>		<b>0</b>	<b>3</b>

2	STK-Q-16055	1	M6 x 18mm Stud (No Paint Cap Required)
1	9412STDD724818DG	0	9412DD 72" x 48" Door Gasket
1	STK-Q-16080	0	Ground Stud M6 x 16mm
1	STK-P-02400S	0	Powder Paint (Asa-61 Grey / Smooth)
1	STK-S-00100	0	3.5" x 2" Silver Milar Flexcon Sticker
1	9412STDD724818LD-P	0	9412DD 72" x 48" Slave Door Part
4	STK-K-09860	7	Cabinet Hinge with Captive Pins
3	STK-K-12580	0	9412 1/4 Turn Lock
Qty	Part Name	Rev	Description
Parts List			

This drawing is confidential and must not be reproduced or used without the consent of EXM

Ce dessin est confidentiel et ne doit pas être reproduit ou utilisé sans le consentement de EXM

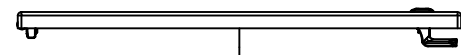

TOP

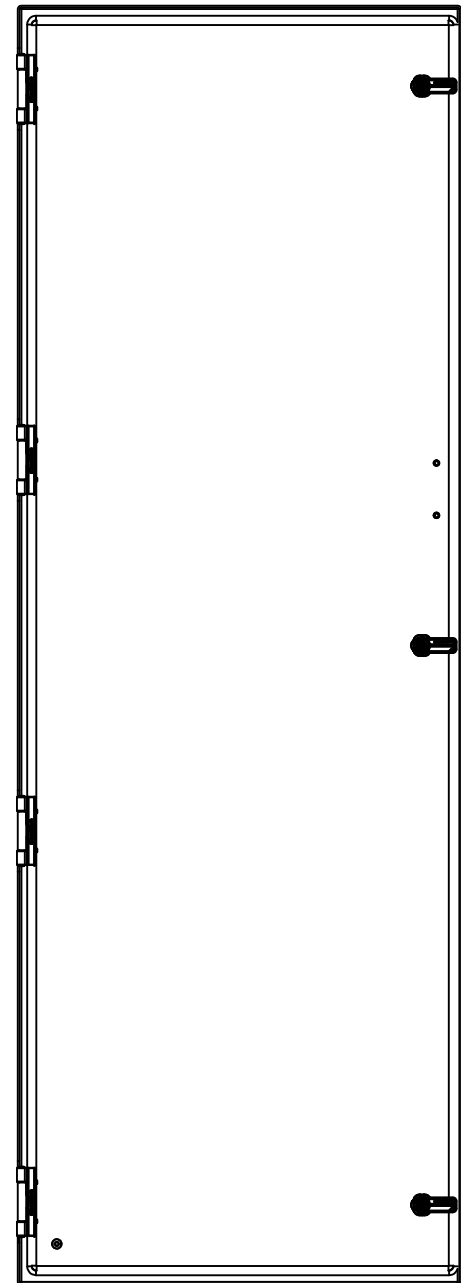

BACK

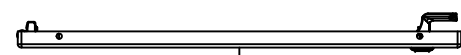

BOTTOM

0.000  
0.835

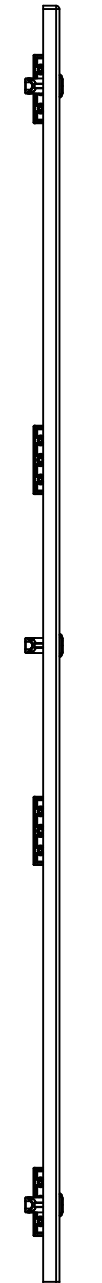

LEFT

22.750

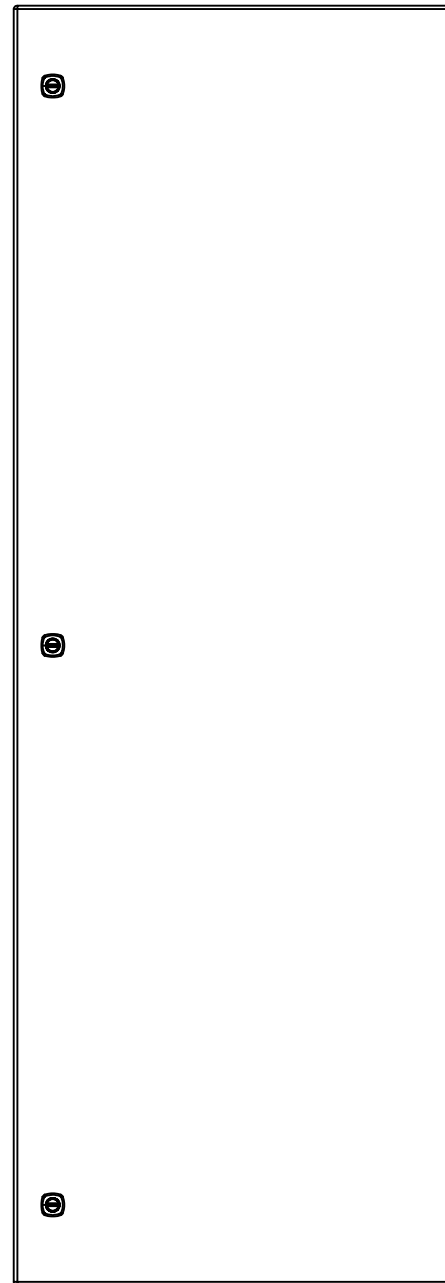

FRONT

0.000

65.549



RIGHT

0.000

No.	Revisions	Date	By/Par

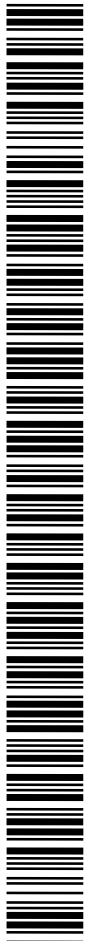
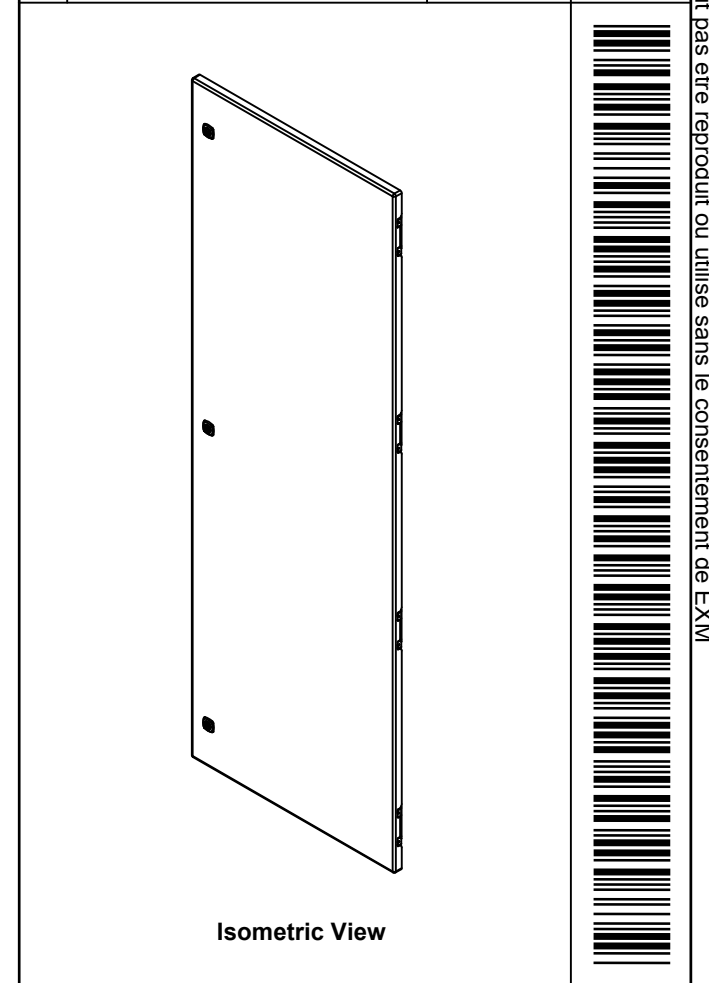

 Tél: (450) 979-4373 Fax: (450) 979-4626 <a href="http://www.exmweb.com">www.exmweb.com</a>		Flatness Aplatissement	
		Max 3.0mm	
Customer Client		Date	
Drawn By Dessiné Par BoxCad: BoxCad		Date 26-Nov-21	
Material Matière 12 Ga Cold Rolled A1008 CS Type B (2.5mm)			
Color Couleur Asa-61 Grey		Finish Fini Smooth	
Description 9412DD 72" x 48" Master Door			Detail Rev.
Part Number Numéro Pièce <b>9412STDD724818FD</b>		Rev. <b>0</b>	1 3

SEE BILL OF MATERIAL ON LAST PAGE

This drawing is confidential and must not be reproduced or used without the consent of EXM

Ce dessin est confidentiel et ne doit pas être reproduit ou utilisé sans le consentement de EXM

**STANDARD FEATURES ARE NOT LISTED IN THIS HOLE TABLE**

**HOLE TABLE - FRONT VIEW (CUSTOM FEATURE ONLY)**

CUT-OUT	XDIM	YDIM	DESCRIPTION
1	20.750	32.774	LOCK 889 SCQ4-SL @ 180.0°
2	20.750	4.118	LOCK 889 SCQ4-SL @ 180.0°
3	2.000	2.118	GND STUD M6 x 16mm (Inside)
4	20.750	61.430	LOCK 889 SCQ4-SL @ 180.0°
5	21.489	39.435	STUDS M6 x 18mm (Inside)
6	21.489	42.113	STUDS M6 x 18mm (Inside)

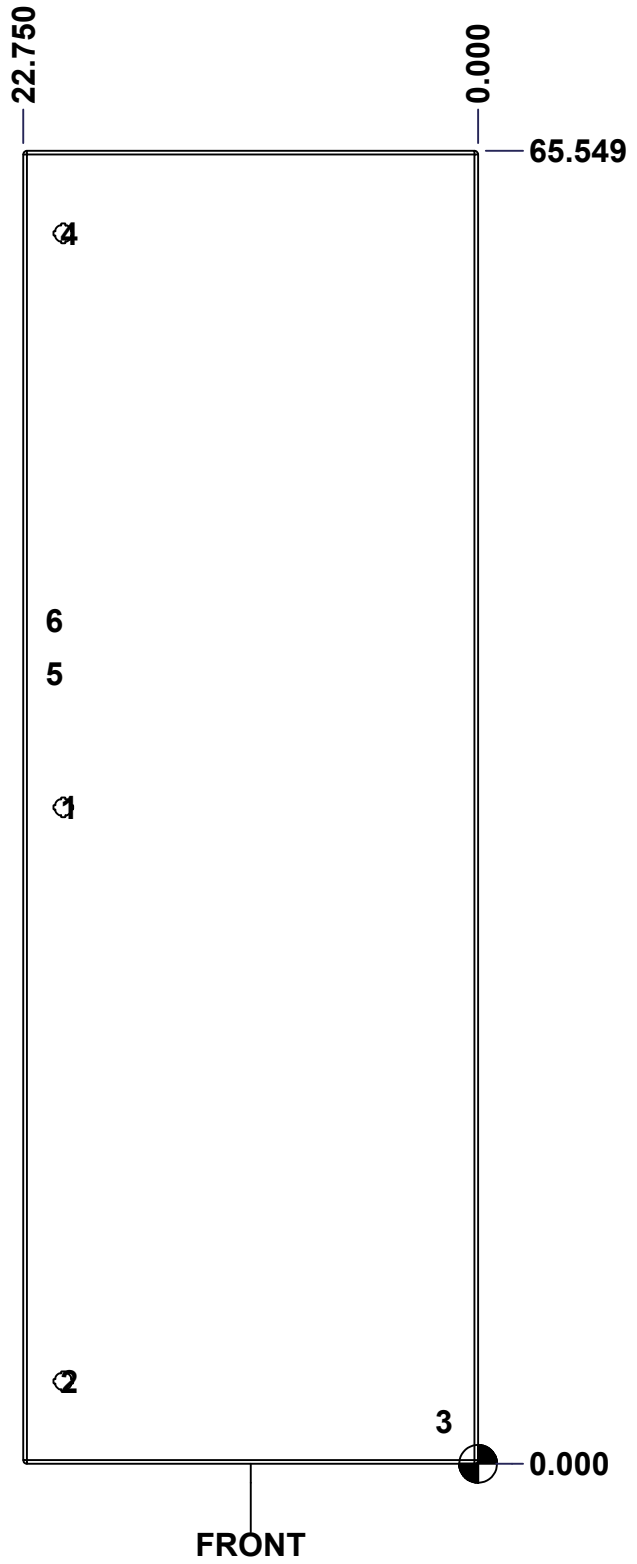

	Description		Status
	9412DD 72" x 48" Master Door		(NULL)
	Part Number Numéro Pièce		Rev.
	<b>9412STDD724818FD</b>		<b>0</b>
		2	3

This drawing is confidential and must not be reproduced or used without the consent of EXM

Ce dessin est confidentiel et ne doit pas être reproduit ou utilisé sans le consentement de EXM

No.	Revisions	Date	By/Par

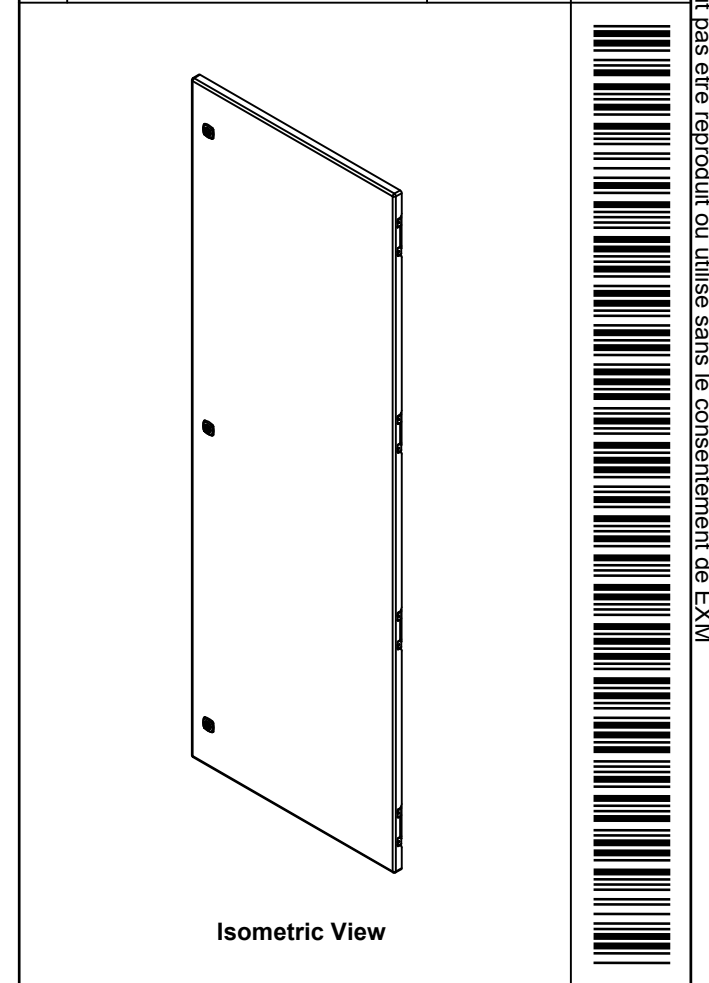

Tél: (450) 979-4373 Fax: (450) 979-4626 <a href="http://www.exmweb.com">www.exmweb.com</a>		Flatness Aplatissement Max 3.0mm Projection 
Customer Client	Date	
Drawn By Dessiné Par	BoxCad: BoxCad	Date 26-Nov-21
Material Matière	12 Ga Cold Rolled A1008 CS Type B (2.5mm)	
Color Couleur	Asa-61 Grey	Finish Fini Smooth
Description		Detail Rev.
9412DD 72" x 48" Master Door		
Part Number Numéro Pièce	Rev.	3
<b>9412STDD724818FD</b>	<b>0</b>	<b>3</b>

2	STK-Q-16055	1	M6 x 18mm Stud (No Paint Cap Required)
1	STK-Q-16080	0	Ground Stud M6 x 16mm
1	9412STDD724818DG	0	9412DD 72" x 48" Door Gasket
1	STK-P-02400S	0	Powder Paint (Asa-61 Grey / Smooth)
1	9412STDD724818FD-P	0	9412DD 72" x 48" Master Door Part
4	STK-K-09860	7	Cabinet Hinge with Captive Pins
3	STK-K-12580	0	9412 1/4 Turn Lock
Qty	Part Name	Rev	Description
Parts List			