

This drawing is confidential and must not be reproduced or used without the consent of EXM

Ce dessin est confidentiel et ne doit pas être reproduit ou utilisé sans le consentement de EXM

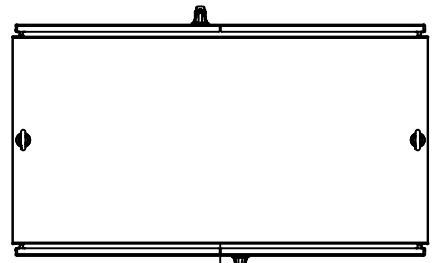

TOP

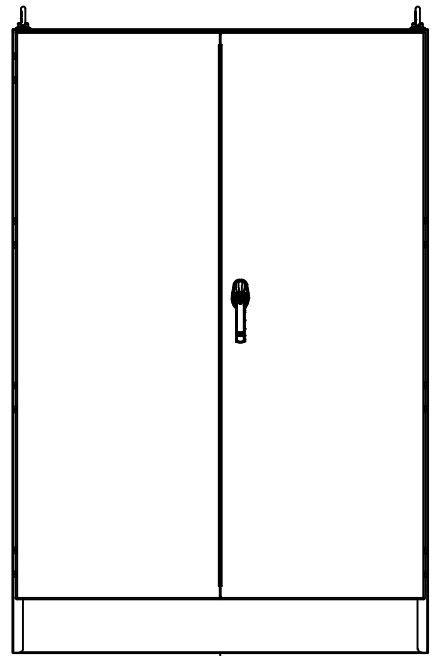

BACK

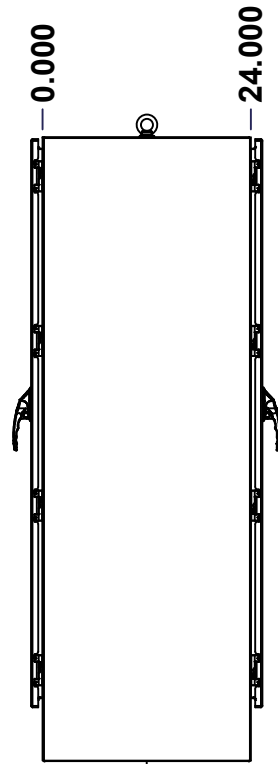

LEFT

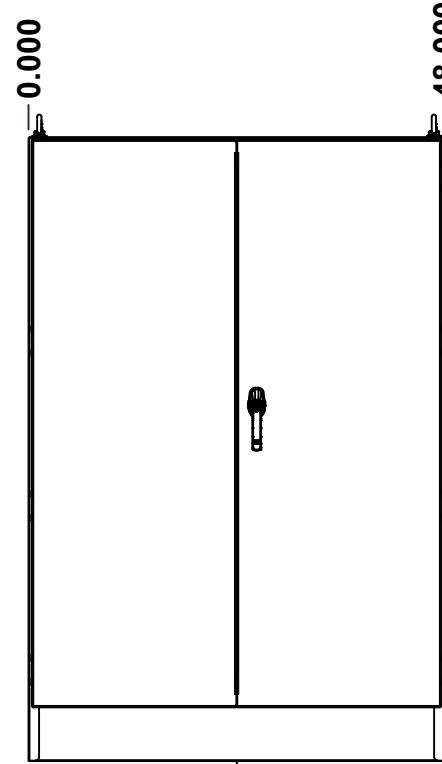

FRONT

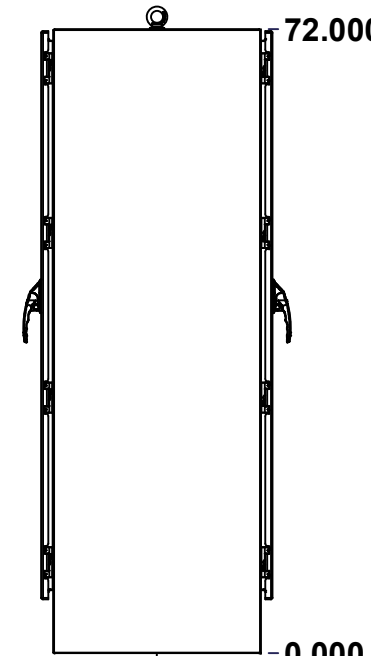

RIGHT

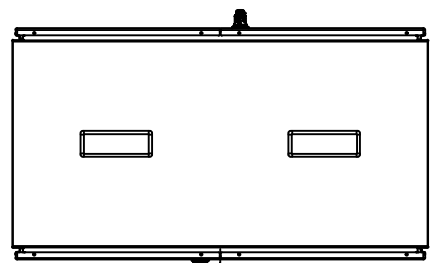

BOTTOM

| No. | Revisions | Date | By/Par |
|-----|-----------|------|--------|
|     |           |      |        |
|     |           |      |        |
|     |           |      |        |
|     |           |      |        |

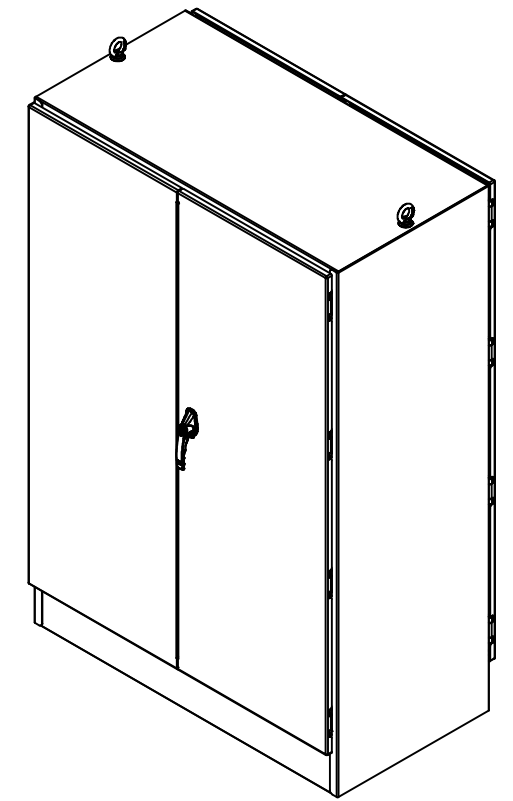

Isometric View



Tél: (450) 979-4373  
 Fax: (450) 979-4626  
[www.exmweb.com](http://www.exmweb.com)

Flatness  
Aplatissement

Max 3.0mm

Projection



|   |                       |
|---|-----------------------|
| Customer Client   | Date                  |
| Drawn By<br>Dessiné Par BoxCad: BoxCad                        | Date 28-Oct-14        |
| Material<br>Matière 12 Ga Cold Rolled A1008 CS Type B (2.5mm) |                       |
| Color<br>Couleur Asa-61 Grey                                  | Finish<br>Fini Smooth |
| Description<br>9500DADD 72" x 48" x 24" Assembly              | Detail Rev.           |
| Part Number<br>Numéro Pièce 9500DADD724824                    | Rev. 1<br>0           |

SEE BILL OF MATERIAL ON LAST PAGE

This drawing is confidential and must not be reproduced or used without the consent of EXM

Ce dessin est confidentiel et ne doit pas être reproduit ou utilisé sans le consentement de EXM

| NOTE |   |
|------|---|
| ITEM | DESCRIPTION                                     |
| 1    | NEMA 12, 13 Enclosure (IP55)                    |
| 2    | C/W Standard ground studs on box and cover      |
| 3    | C/W Standard door stiffener                     |
| 4    | W/O Inner panel                                 |
| 5    | C/W Standard inner panel mounting struts        |
| 6    | C/W Eyebolts sold separately (Installed by EXM) |
| 7    | C/W Struts installed (Included)                 |

| No. | Revisions | Date | By/Par |
|-----|-----------|------|--------|
|     |           |      |        |
|     |           |      |        |
|     |           |      |        |
|     |           |      |        |
|     |           |      |        |
|     |           |      |        |

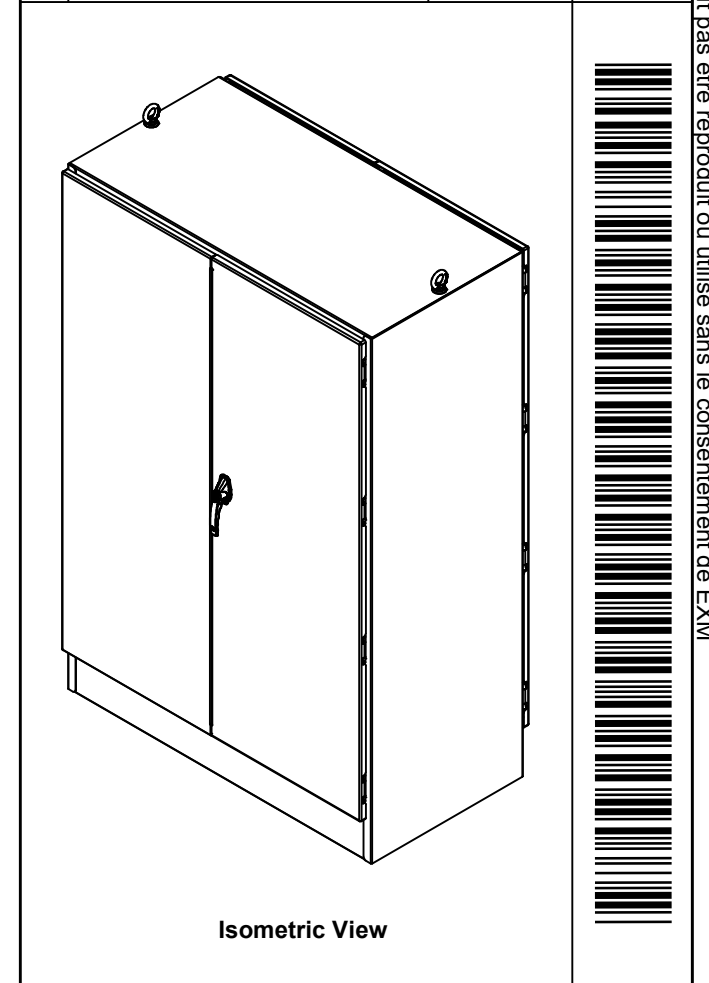

| PACKING               |     |  |
|-----------------------|-----|--|
| ITEM                  | QTY | DESCRIPTION                                    |
| Cardboard sleeve      | 2   | Top and Bottom                                 |
| Cardboard strip       | 2   | Between back of enclosure and inner panel      |
| Plastic bag           | 1   | To protect cover surface and inside gasket     |
| Cardboard corner      | 4   | To reinforced for the plastic strap tightening |
| Plastic strap - Black | 2   | To Squeeze 2 cardboard sleeve together         |
| Packaging label       | 3   | White label with PN                            |
| Plastic strap- Green  | 2   | To secure the enclosure to the wood pallet     |
| Wood Pallet           | 1   | 2" deeper and 3" larger than enclosure size    |

|            |                  |     |   |
|------------|------------------|-----|---|
| 1          | 880EB14          | 2   | Eye Bolt M14 (Pack of 2)                                |
| 1          | 889BPS           | 0   | Inner Panel Strut Mounting Kit                          |
| 1          | 9500DADD724824FB | 0   | 9500DADD 72" x 48" Back Flange Door                     |
| 1          | 9500DADD724824LB | 0   | 9500DADD 72" x 48" Back Lock Door                       |
| 1          | 9500DADD724824FD | 0   | 9500DADD 72" x 48" Front Flange Door                    |
| 1          | 9500DADD724824LD | 0   | 9500DADD 72" x 48" Front Lock Door                      |
| 1          | 9500DADD724824B  | 0   | 9500DADD 72" x 48" x 24" Body                           |
| 2          | 9500DADD724824GP | 0   | 9500DADD Gland Plate                                    |
| 16         | STK-Q-04050-10   | 8   | M6 x 10mm Hexagon Socket Head Machine Screw with Nyseal |
| Qty        | Part Number      | Rev | Description   |
| Parts List |                  |     |   |

|  |  |  |
|--|--|--|
|  | Tél: (450) 979-4373<br>Fax: (450) 979-4626<br><a href="http://www.exmweb.com">www.exmweb.com</a> | Flatness<br>Aplatissement<br>Max 3.0mm                           |
|  | Projection<br>   | Customer Client<br>Date  |
| Drawn By<br>Dessiné Par<br>BoxCad: BoxCad            | Date<br>28-Oct-14  | Material<br>Matière<br>12 Ga Cold Rolled A1008 CS Type B (2.5mm) |
| Color<br>Couleur<br>Asa-61 Grey                      | Finish<br>Fini<br>Smooth   | Description<br>9500DADD 72" x 48" x 24" Assembly                 |
| Part Number<br>Numéro Pièce<br><b>9500DADD724824</b> | Rev.<br><b>0</b>   | Detail Rev.<br>2<br>21   |

This drawing is confidential and must not be reproduced or used without the consent of EXM

Ce dessin est confidentiel et ne doit pas être reproduit ou utilisé sans le consentement de EXM

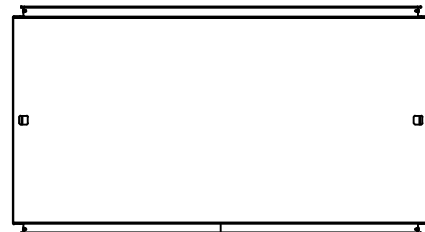

TOP

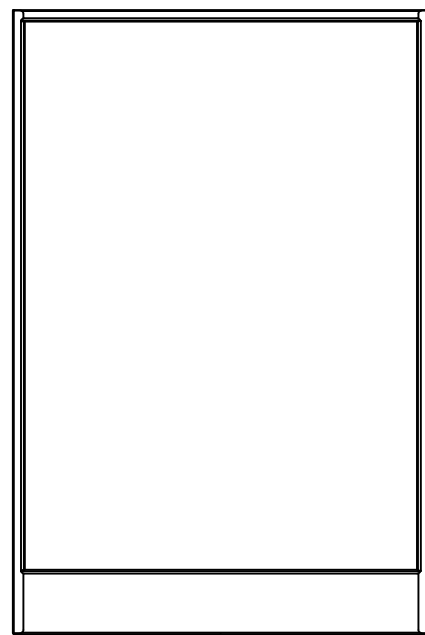

BACK

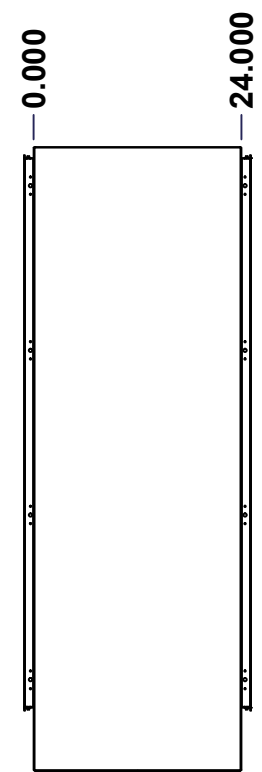

LEFT

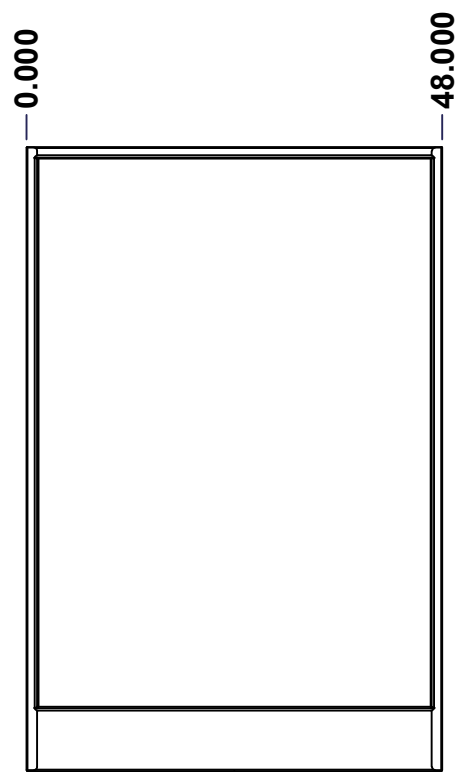

FRONT

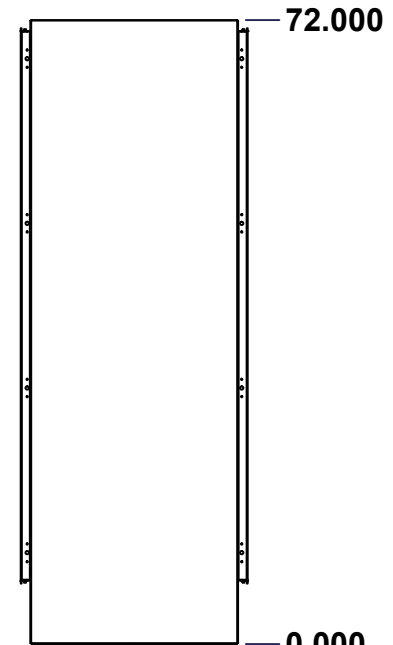

RIGHT

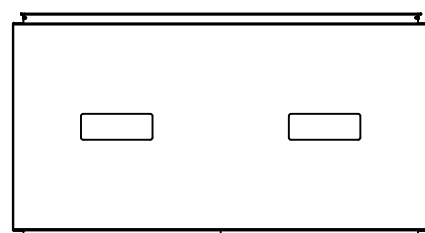

BOTTOM

| No. | Revisions | Date | By/Par |
|-----|-----------|------|--------|
|     |           |      |        |
|     |           |      |        |
|     |           |      |        |
|     |           |      |        |

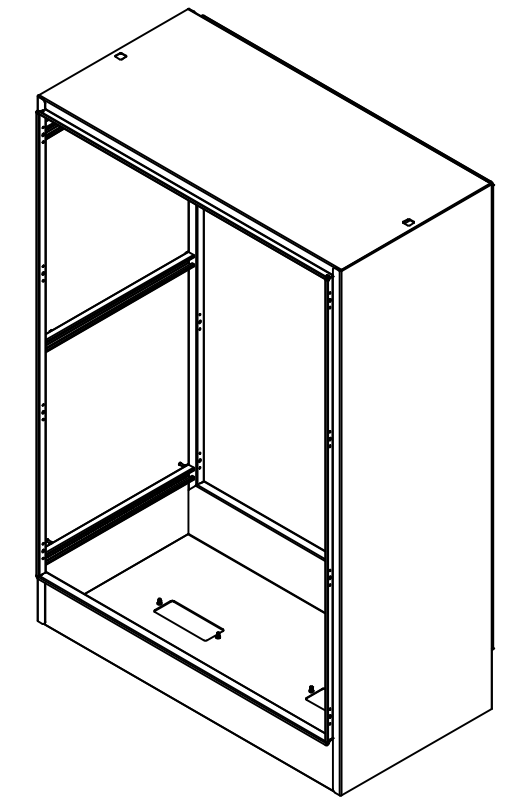

Isometric View

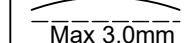
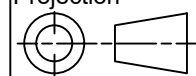

|  |  |
|--|--|
|  Tél: (450) 979-4373<br>Fax: (450) 979-4626<br><a href="http://www.exmweb.com">www.exmweb.com</a> | Flatness<br>Aplatissement<br> Max 3.0mm |
|  | Projection<br>                          |
| Customer Client  | Date   |
| Drawn By<br>Dessiné Par BoxCad: BoxCad   | Date 28-Oct-14   |
| Material<br>Matière 12 Ga Cold Rolled A1008 CS Type B (2.5mm)  |  |
| Color<br>Couleur Asa-61 Grey   | Finish<br>Fini Smooth  |
| Description<br>9500DADD 72" x 48" x 24" Body   |  |
| Detail Rev.  |  |
| Part Number<br>Numéro Pièce <b>9500DADD724824B</b>   | Rev. 3<br><b>0</b>   |

SEE BILL OF MATERIAL ON LAST PAGE

This drawing is confidential and must not be reproduced or used without the consent of EXM

Ce dessin est confidentiel et ne doit pas être reproduit ou utilisé sans le consentement de EXM

| STANDARD FEATURES ARE NOT LISTED IN THIS HOLE TABLE |        |        |                               |
|---|--------|--------|-------------------------------|
| HOLE TABLE - TOP VIEW (CUSTOM FEATURE ONLY)         |        |        |                               |
| CUT-OUT   | XDIM   | YDIM   | DESCRIPTION                   |
| 1   | 11.911 | 20.000 | Struts CR400 17.500" (Inside) |
| 2   | 35.911 | 20.000 | Struts CR400 17.500" (Inside) |
| 3   | 11.911 | 20.929 | STUDS M6 x 10mm (Inside)      |
| 4   | 20.777 | 20.000 | STUDS M6 x 10mm (Inside)      |
| 5   | 35.911 | 20.929 | STUDS M6 x 10mm (Inside)      |
| 6   | 44.777 | 20.000 | STUDS M6 x 10mm (Inside)      |

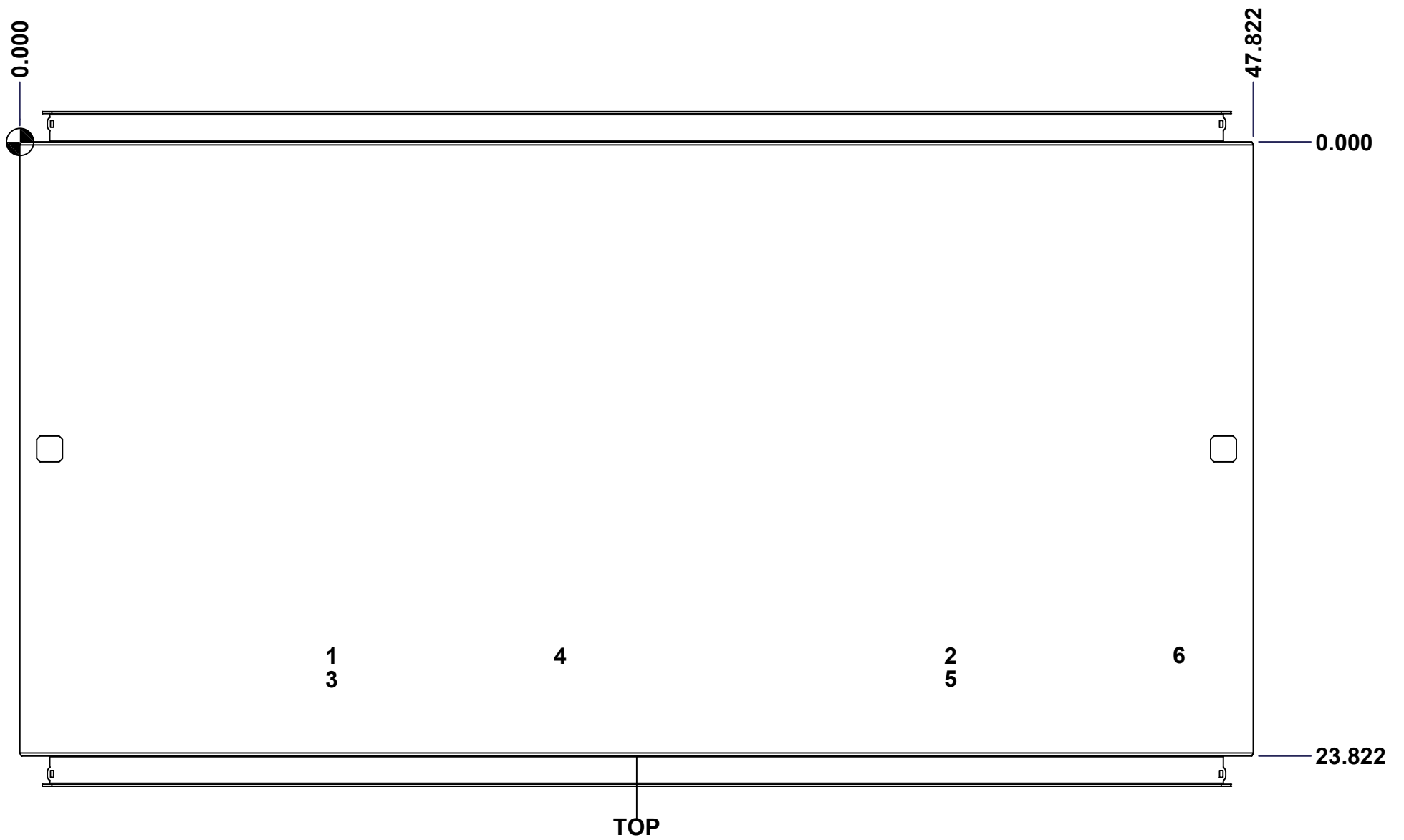

|   |                               |        |
|---|-------------------------------|--------|
|   | Description                   | Status |
|   | 9500DADD 72" x 48" x 24" Body | (NULL) |
| Part Number<br>Numéro Pièce<br><b>9500DADD724824B</b> | Rev.                          | 4      |
|   | <b>0</b>                      | 21     |

This drawing is confidential and must not be reproduced or used without the consent of EXM

Ce dessin est confidentiel et ne doit pas être reproduit ou utilisé sans le consentement de EXM

**STANDARD FEATURES ARE NOT LISTED IN THIS HOLE TABLE**

**HOLE TABLE - RIGHT VIEW (CUSTOM FEATURE ONLY)**

| CUT-OUT | XDIM   | YDIM   | DESCRIPTION                 |
|---------|--------|--------|-----------------------------|
| 1       | 1.500  | 10.286 | GND STUD M6 x 16mm (Inside) |
| 2       | 22.500 | 10.286 | GND STUD M6 x 16mm (Inside) |
| 3       | 7.625  | 66.107 | STUDS M6 x 10mm (Inside)    |
| 4       | 16.375 | 66.107 | STUDS M6 x 10mm (Inside)    |
| 5       | 7.625  | 7.857  | STUDS M6 x 10mm (Inside)    |
| 6       | 16.375 | 7.857  | STUDS M6 x 10mm (Inside)    |
| 7       | 7.625  | 36.982 | STUDS M6 x 10mm (Inside)    |
| 8       | 16.375 | 36.982 | STUDS M6 x 10mm (Inside)    |

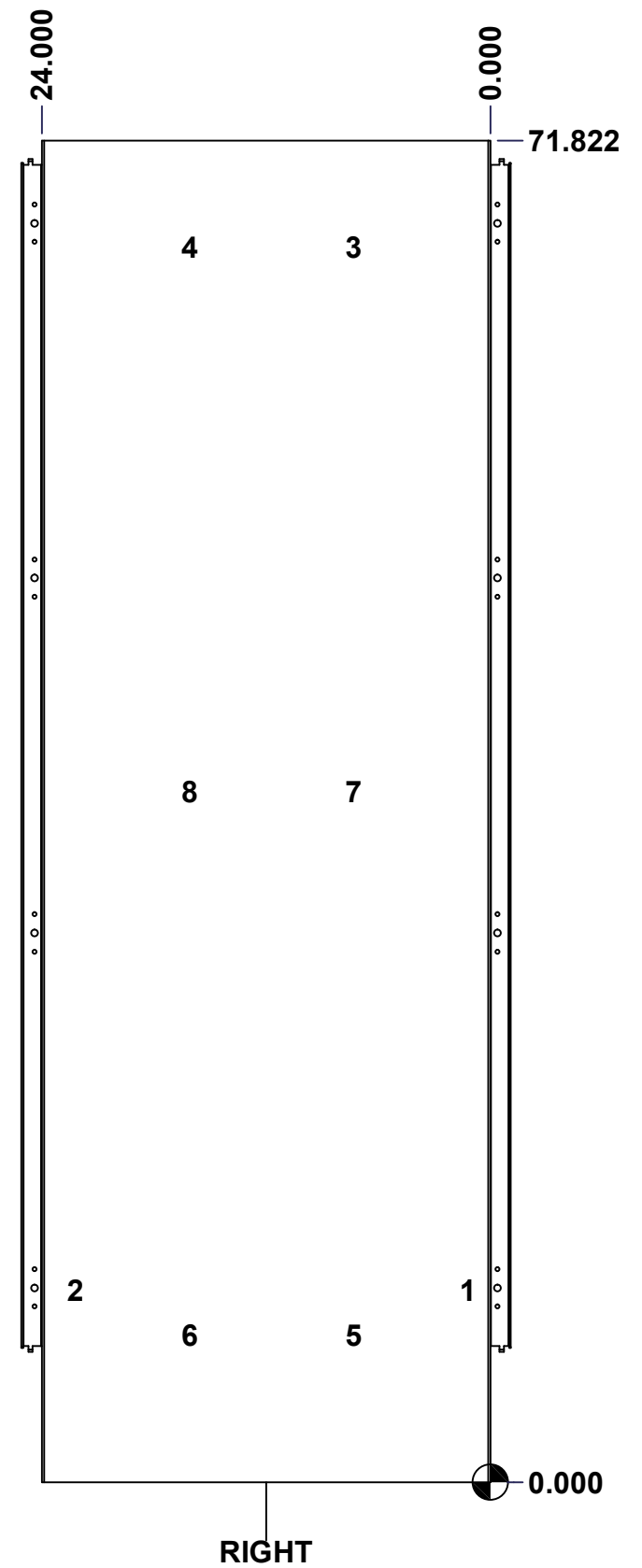

|  |                               |  |              |
|--|-------------------------------|--|--------------|
|  | Description                   |  | Status       |
|  | 9500DADD 72" x 48" x 24" Body |  | (NULL)       |
|  | Part Number<br>Numéro Pièce   |  | Rev.         |
|  | <b>9500DADD724824B</b>        |  | <b>0</b> / 5 |
|  |                               |  | 21           |

This drawing is confidential and must not be reproduced or used without the consent of EXM

Ce dessin est confidentiel et ne doit pas être reproduit ou utilisé sans le consentement de EXM

**STANDARD FEATURES ARE NOT LISTED IN THIS HOLE TABLE**

**HOLE TABLE - BOTTOM VIEW (CUSTOM FEATURE ONLY)**

| CUT-OUT | XDIM   | YDIM   | DESCRIPTION                |
|---------|--------|--------|----------------------------|
| 1       | 7.286  | 12.000 | GP STUD M6 x 16mm (Inside) |
| 2       | 16.536 | 12.000 | GP STUD M6 x 16mm (Inside) |
| 3       | 31.286 | 12.000 | GP STUD M6 x 16mm (Inside) |
| 4       | 40.536 | 12.000 | GP STUD M6 x 16mm (Inside) |

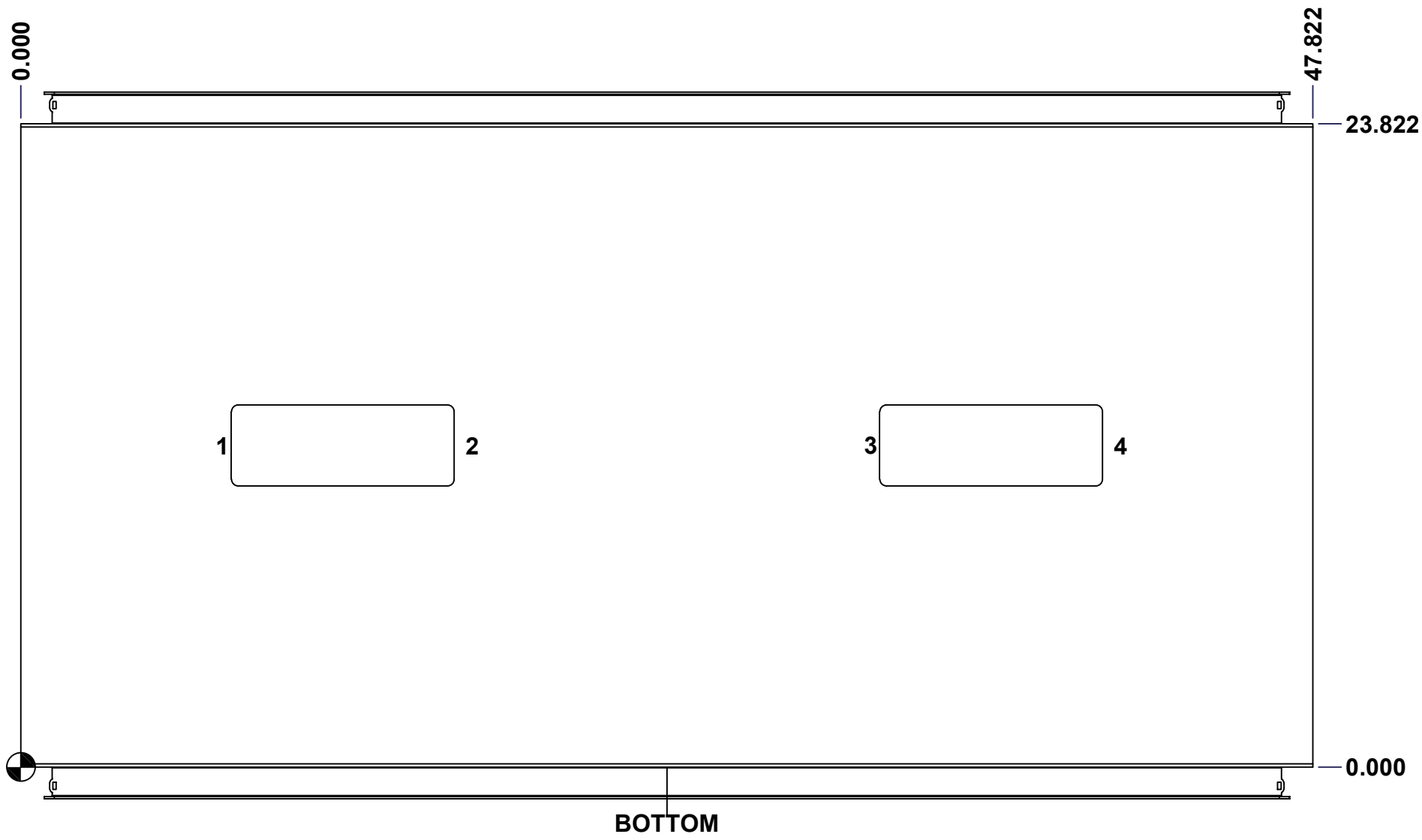

|  |                               |              |
|--|-------------------------------|--------------|
|  | Description                   | Status       |
|  | 9500DADD 72" x 48" x 24" Body | (NULL)       |
|  | Part Number<br>Numéro Pièce   | Rev.         |
|  | <b>9500DADD724824BB</b>       | <b>0</b> / 6 |
|  |                               | 21           |

This drawing is confidential and must not be reproduced or used without the consent of EXM

Ce dessin est confidentiel et ne doit pas être reproduit ou utilisé sans le consentement de EXM

**STANDARD FEATURES ARE NOT LISTED IN THIS HOLE TABLE**

**HOLE TABLE - LEFT VIEW (CUSTOM FEATURE ONLY)**

| CUT-OUT | XDIM   | YDIM   | DESCRIPTION                 |
|---------|--------|--------|-----------------------------|
| 1       | 1.411  | 10.286 | GND STUD M6 x 16mm (Inside) |
| 2       | 22.411 | 10.286 | GND STUD M6 x 16mm (Inside) |
| 3       | 7.536  | 66.107 | STUDS M6 x 10mm (Inside)    |
| 4       | 16.286 | 66.107 | STUDS M6 x 10mm (Inside)    |
| 5       | 7.536  | 7.857  | STUDS M6 x 10mm (Inside)    |
| 6       | 16.286 | 7.857  | STUDS M6 x 10mm (Inside)    |
| 7       | 16.286 | 36.982 | STUDS M6 x 10mm (Inside)    |
| 8       | 7.536  | 36.982 | STUDS M6 x 10mm (Inside)    |

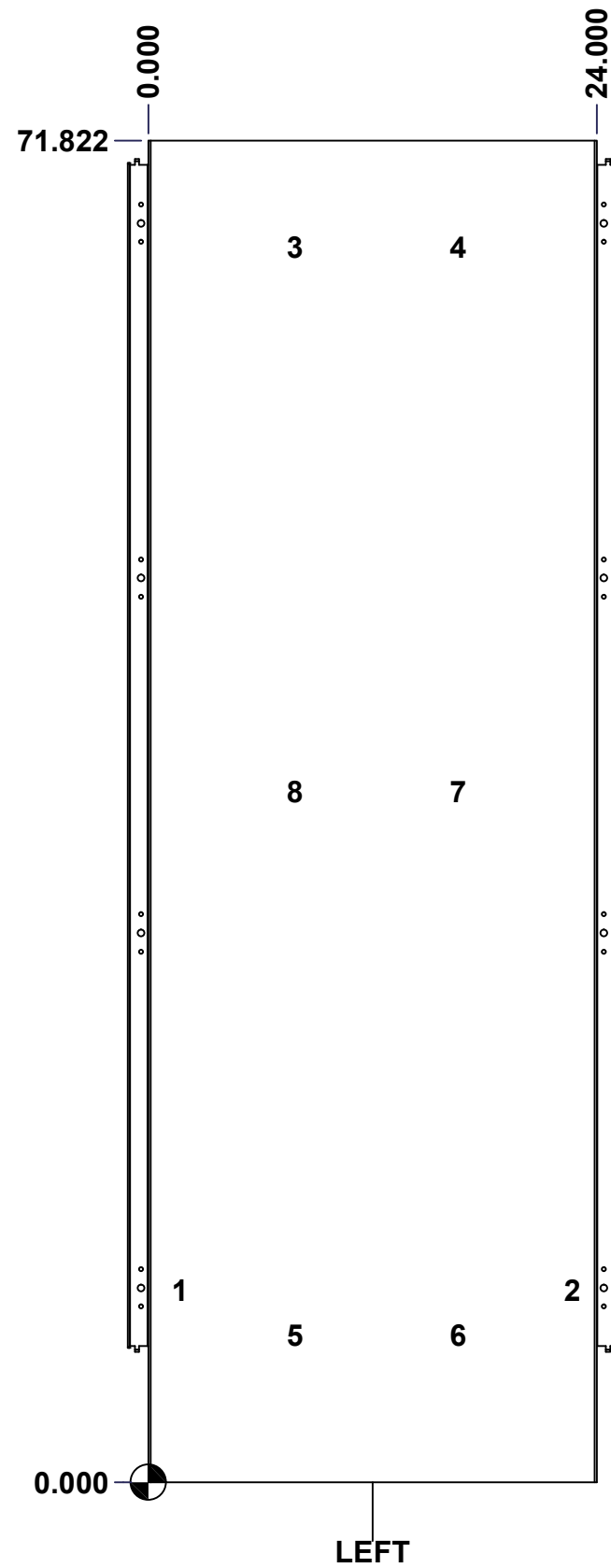

|  |                               |              |
|--|-------------------------------|--------------|
|  | Description                   | Status       |
|  | 9500DADD 72" x 48" x 24" Body | (NULL)       |
|  | Part Number<br>Numéro Pièce   | Rev.         |
|  | <b>9500DADD724824B</b>        | <b>0</b> / 7 |
|  |                               | 21           |



This drawing is confidential and must not be reproduced or used without the consent of EXM

Ce dessin est confidentiel et ne doit pas être reproduit ou utilisé sans le consentement de EXM

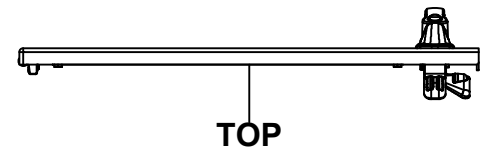

TOP

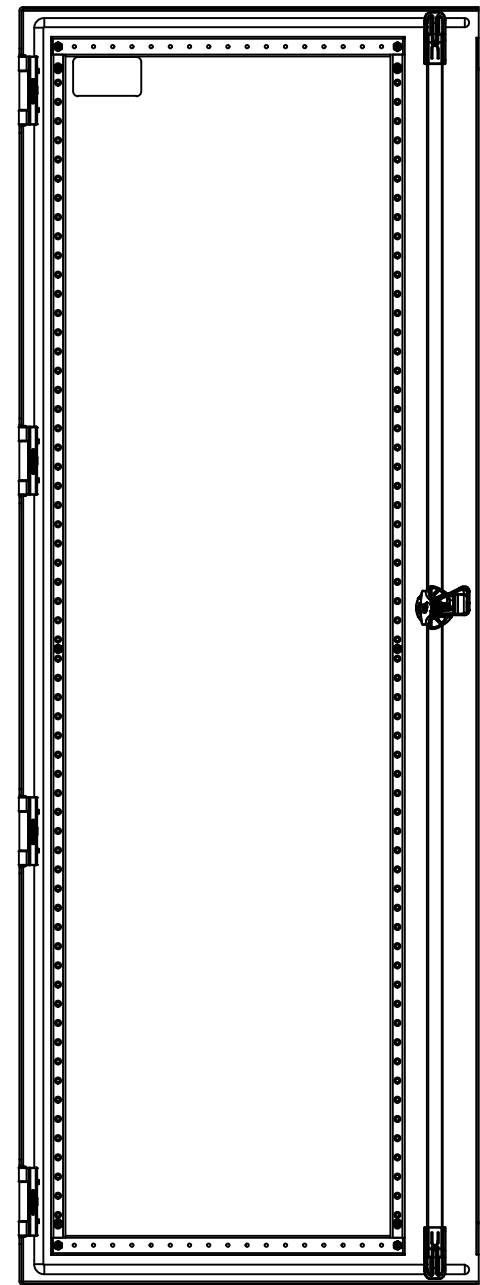

BACK



BOTTOM

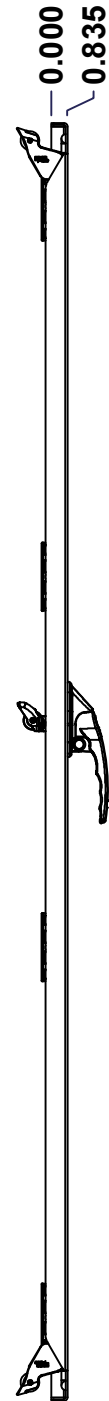

LEFT

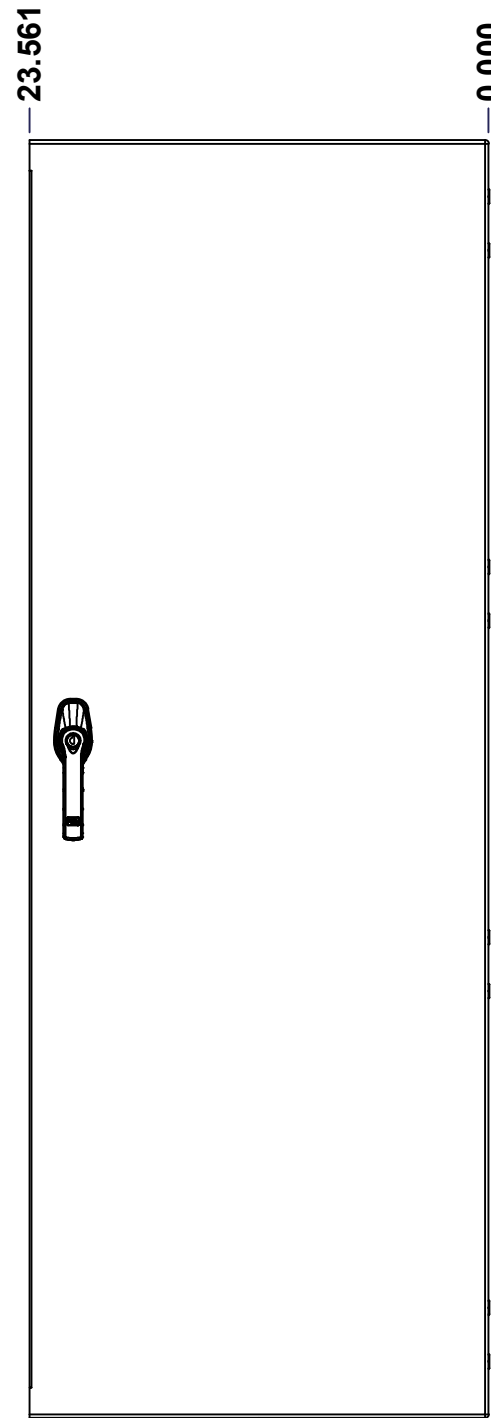

FRONT

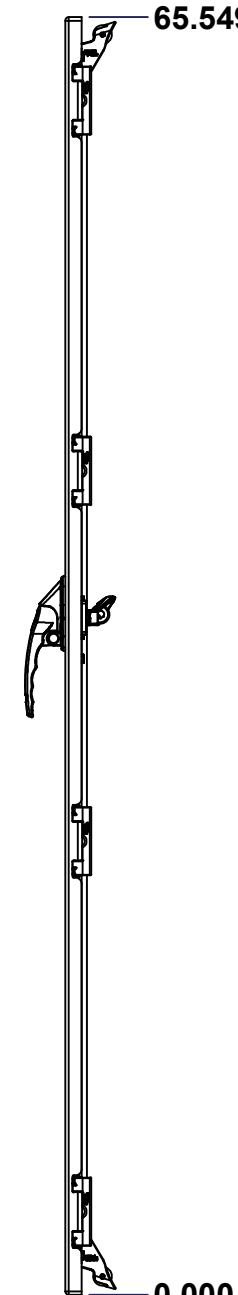

RIGHT

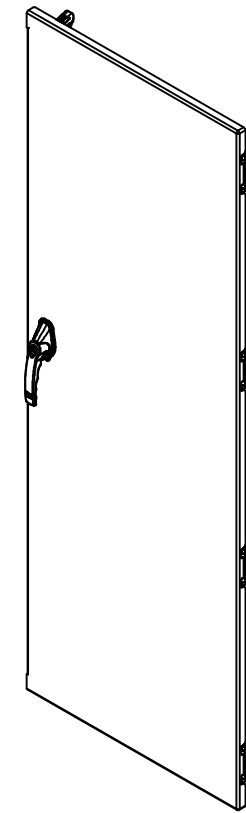

Isometric View

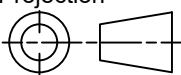

| No. | Revisions | Date | By/Par |
|-----|-----------|------|--------|
|     |           |      |        |
|     |           |      |        |
|     |           |      |        |
|     |           |      |        |
|     |           |      |        |

|  |   |   |
|--|---|---|
|  Tél: (450) 979-4373<br>Fax: (450) 979-4626<br><a href="http://www.exmweb.com">www.exmweb.com</a> |   | Flatness<br>Aplatissement<br>Max 3.0mm<br>Projection<br> |
| Customer<br>Client   |   | Date  |
| Drawn By<br>Dessiné Par  | BoxCad: BoxCad                            | Date 28-Oct-14  |
| Material<br>Matière  | 12 Ga Cold Rolled A1008 CS Type B (2.5mm) |   |
| Color<br>Couleur   | Asa-61 Grey                               | Finish<br>Fini Smooth   |
| Description  |   | Detail Rev.   |
| 9500DADD 72" x 48" Front Lock Door   |   |   |
| Part Number<br>Numéro Pièce  | Rev. 9                                    | 21  |
| 9500DADD724824LD   |   | 0   |

SEE BILL OF MATERIAL ON LAST PAGE

This drawing is confidential and must not be reproduced or used without the consent of EXM

Ce dessin est confidentiel et ne doit pas être reproduit ou utilisé sans le consentement de EXM

| STANDARD FEATURES ARE NOT LISTED IN THIS HOLE TABLE |        |        |                              |
|---|--------|--------|------------------------------|
| HOLE TABLE - FRONT VIEW (CUSTOM FEATURE ONLY)       |        |        |                              |
| CUT-OUT   | XDIM   | YDIM   | DESCRIPTION                  |
| 1   | 1.983  | 2.028  | STUD M6 x 18mm (Inside)      |
| 2   | 1.983  | 32.628 | STUD M6 x 18mm (Inside)      |
| 3   | 1.983  | 63.521 | STUD M6 x 18mm (Inside)      |
| 4   | 1.983  | 3.139  | STUD M6 x 18mm (Inside)      |
| 5   | 1.983  | 62.409 | STUD M6 x 18mm (Inside)      |
| 6   | 19.390 | 2.028  | STUD M6 x 18mm (Inside)      |
| 7   | 19.390 | 32.628 | STUD M6 x 18mm (Inside)      |
| 8   | 19.390 | 63.521 | STUD M6 x 18mm (Inside)      |
| 9   | 19.390 | 3.139  | STUD M6 x 18mm (Inside)      |
| 10  | 19.390 | 62.409 | STUD M6 x 18mm (Inside)      |
| 11  | 21.311 | 6.118  | LARGE CBAR GUIDE (Inside)    |
| 12  | 21.311 | 59.430 | LARGE CBAR GUIDE (Inside)    |
| -----   | -----  | -----  | -----                        |
| 13  | 21.311 | 34.743 | HANDLE 885 ESL2A-APHK @ 0.0° |

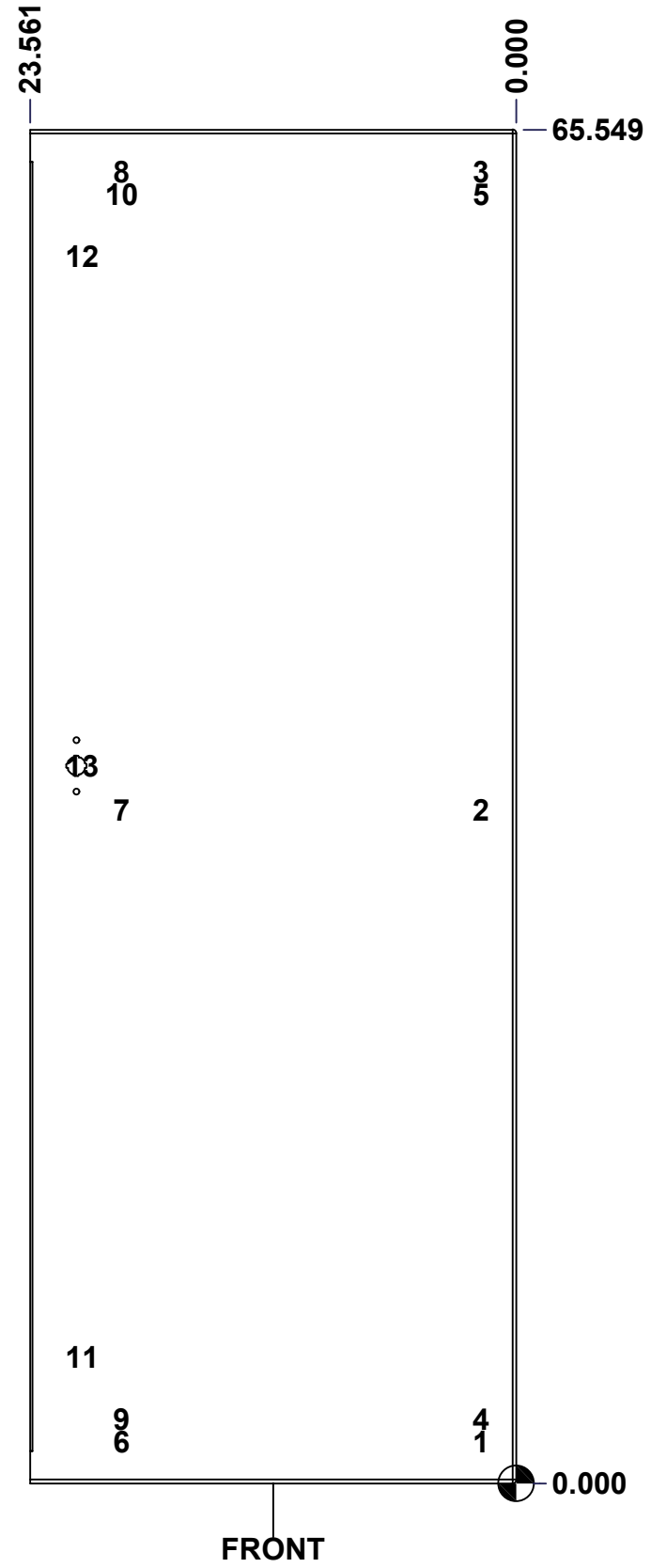

|  |                                    |          |
|--|------------------------------------|----------|
|  | Description                        | Status   |
|  | 9500DADD 72" x 48" Front Lock Door | (NULL)   |
|  | Part Number<br>Numéro Pièce        | Rev.     |
|  | <b>9500DADD724824LD</b>            | <b>0</b> |
|  |                                    | 10       |
|  |                                    | 21       |

This drawing is confidential and must not be reproduced or used without the consent of EXM

Ce dessin est confidentiel et ne doit pas être reproduit ou utilisé sans le consentement de EXM

| No. | Revisions | Date | By/Par |
|-----|-----------|------|--------|
|     |           |      |        |
|     |           |      |        |
|     |           |      |        |
|     |           |      |        |
|     |           |      |        |

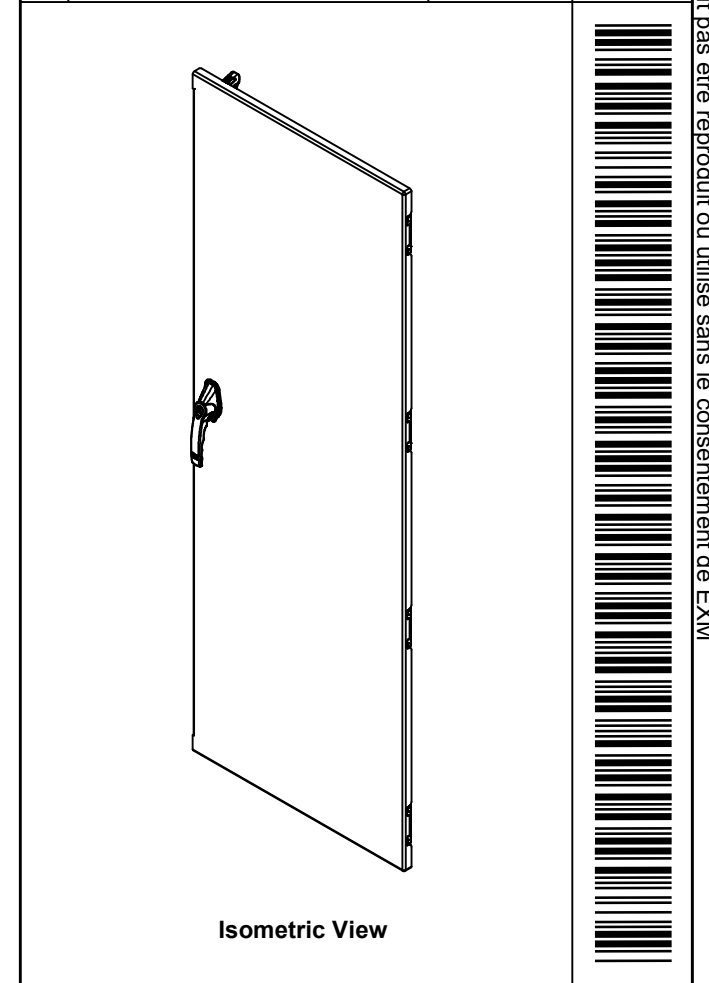

|    |                    |   |  |
|----|--------------------|---|--|
| 1  | STK-Q-47562        | 0 | 9500 Lower Closing Bar 72" (cam)                         |
| 1  | STK-Q-47552        | 0 | 9500 Upper Closing Bar 72" (cam)                         |
| 1  | STK-A-50537        | 3 | 9500 Handle Cam Assembly (Left Side, Grip 36mm)          |
| 1  | STK-Q-90051        | 3 | 5412 ES - Handle Cam Spacer                              |
| 1  | 885ESL2A-APHK      | 7 | 885 ESL2A-APHK - Zinc Die Cast L-Handle Padlockable Assy |
| 1  | STK-P-02400S       | 0 | Powder Paint (Asa-61 Grey / Smooth)                      |
| 1  | STK-S-00100        | 0 | 3.5" x 2" Silver Milar Flexcon Sticker                   |
| 1  | STK-K-10830        | 3 | 9500 - Door Stiffener Assembly                           |
| 2  | STK-Q-16410        | 0 | Guide Stud - Largel (No Paint Cap Required)              |
| 10 | STK-Q-16055        | 1 | M6 x 18mm Stud (No Paint Cap Required)                   |
| 1  | 9500DADD724824LDG  | 0 | 9500DADD 72" x 48" Lock Door Gasket                      |
| 1  | 9500DADD724824LD-P | 0 | 9500DADD 72" x 48" Front Lock Door Part                  |
| 2  | STK-A-90025        | 0 | 9500 - Cabinet Closing Bar End (Large)                   |
| 4  | STK-K-09860        | 7 | Cabinet Hinge with Captive Pins                          |
| 2  | STK-Q-07220        | 1 | M6 Nylon Insert Lock Nut                                 |

| QTY        | Part Number | Rev | Description |
|------------|-------------|-----|-------------|
| Parts List |             |     |             |

|  |   |                       |
|--|---|-----------------------|
| Tél: (450) 979-4373<br>Fax: (450) 979-4626<br><a href="http://www.exmweb.com">www.exmweb.com</a> | Flatness<br>Aplatissement                 | Max 3.0mm             |
|  | Projection                                |                       |
| Customer<br>Client   | Date                                      |                       |
| Drawn By<br>Dessiné Par  | BoxCad: BoxCad                            | Date 28-Oct-14        |
| Material<br>Matière  | 12 Ga Cold Rolled A1008 CS Type B (2.5mm) |                       |
| Color<br>Couleur   | Asa-61 Grey                               | Finish<br>Fini Smooth |
| Description  | 9500DADD 72" x 48" Front Lock Door        |                       |
| Part Number<br>Numéro Pièce  | Rev. 0                                    | 11 / 21               |
| <b>9500DADD724824LD</b>  |   |                       |

This drawing is confidential and must not be reproduced or used without the consent of EXM

Ce dessin est confidentiel et ne doit pas être reproduit ou utilisé sans le consentement de EXM



TOP

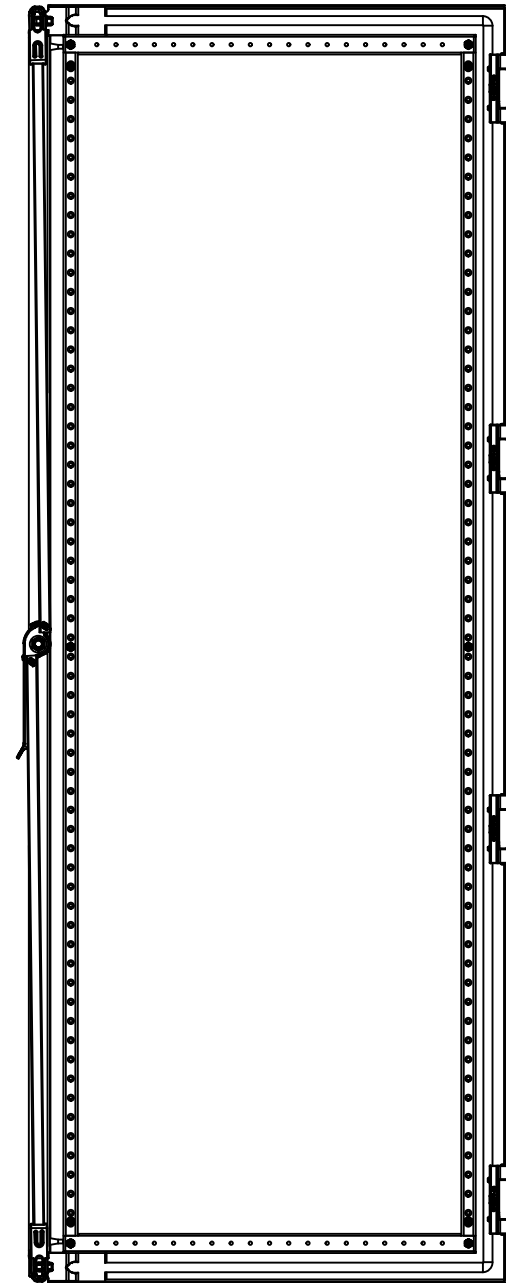

BACK

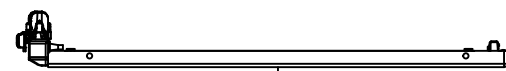

BOTTOM

0.000  
0.835



LEFT

0.000

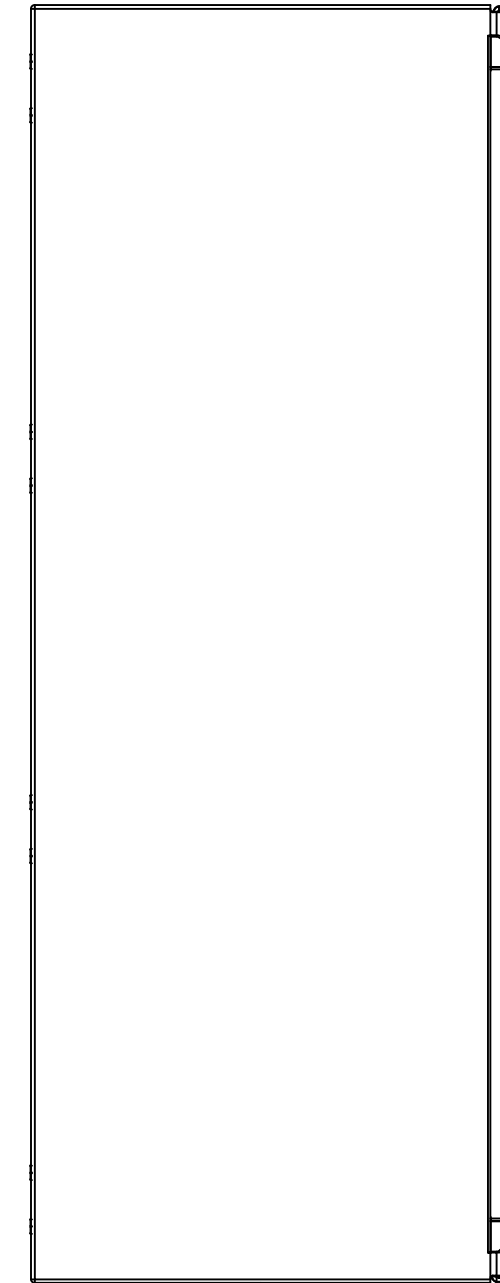

FRONT

23.561

65.549



RIGHT

0.000

| No. | Revisions | Date | By/Par |
|-----|-----------|------|--------|
|     |           |      |        |
|     |           |      |        |
|     |           |      |        |
|     |           |      |        |
|     |           |      |        |

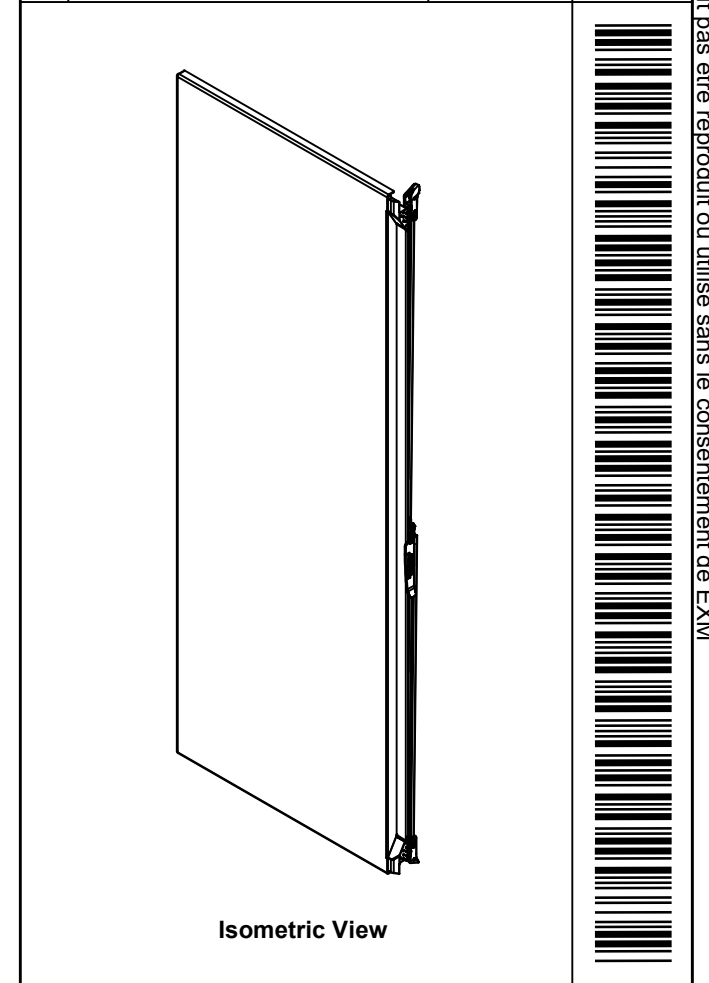

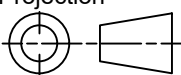
|  |   |                           |
|--|---|---------------------------|
|  Tél: (450) 979-4373<br>Fax: (450) 979-4626<br><a href="http://www.exmweb.com">www.exmweb.com</a> |   | Flatness<br>Aplatissement |
|  |   | Max 3.0mm                 |
| Projection<br>  |   | Date                      |
| Customer<br>Client   | BoxCad: BoxCad                            | Date                      |
| Drawn By<br>Dessiné Par  | BoxCad: BoxCad                            | 28-Oct-14                 |
| Material<br>Matière  | 12 Ga Cold Rolled A1008 CS Type B (2.5mm) |                           |
| Color<br>Couleur   | Asa-61 Grey                               | Finish<br>Fini            |
| Description  |   | Detail Rev.               |
| 9500DADD 72" x 48" Front Flange Door   |   |                           |
| Part Number<br>Numéro Pièce  | Rev.                                      | 12                        |
| 9500DADD724824FD   | 0   | 21                        |

SEE BILL OF MATERIAL ON LAST PAGE

This drawing is confidential and must not be reproduced or used without the consent of EXM

Ce dessin est confidentiel et ne doit pas être reproduit ou utilisé sans le consentement de EXM

**STANDARD FEATURES ARE NOT LISTED IN THIS HOLE TABLE**

**HOLE TABLE - FRONT VIEW (CUSTOM FEATURE ONLY)**

| CUT-OUT | XDIM   | YDIM   | DESCRIPTION               |
|---------|--------|--------|---------------------------|
| 1       | 2.000  | 2.028  | STUD M6 x 18mm (Inside)   |
| 2       | 2.000  | 32.628 | STUD M6 x 18mm (Inside)   |
| 3       | 2.000  | 63.521 | STUD M6 x 18mm (Inside)   |
| 4       | 2.000  | 3.139  | STUD M6 x 18mm (Inside)   |
| 5       | 2.000  | 62.409 | STUD M6 x 18mm (Inside)   |
| 6       | 22.407 | 2.028  | STUD M6 x 18mm (Inside)   |
| 7       | 22.407 | 32.628 | STUD M6 x 18mm (Inside)   |
| 8       | 22.407 | 63.521 | STUD M6 x 18mm (Inside)   |
| 9       | 22.407 | 3.139  | STUD M6 x 18mm (Inside)   |
| 10      | 22.407 | 62.409 | STUD M6 x 18mm (Inside)   |
| 11      | 24.061 | 4.774  | SMALL CBAR GUIDE (Inside) |
| 12      | 24.061 | 60.775 | SMALL CBAR GUIDE (Inside) |
| 13      | 24.061 | 32.774 | STUD M10 x 25mm (Inside)  |

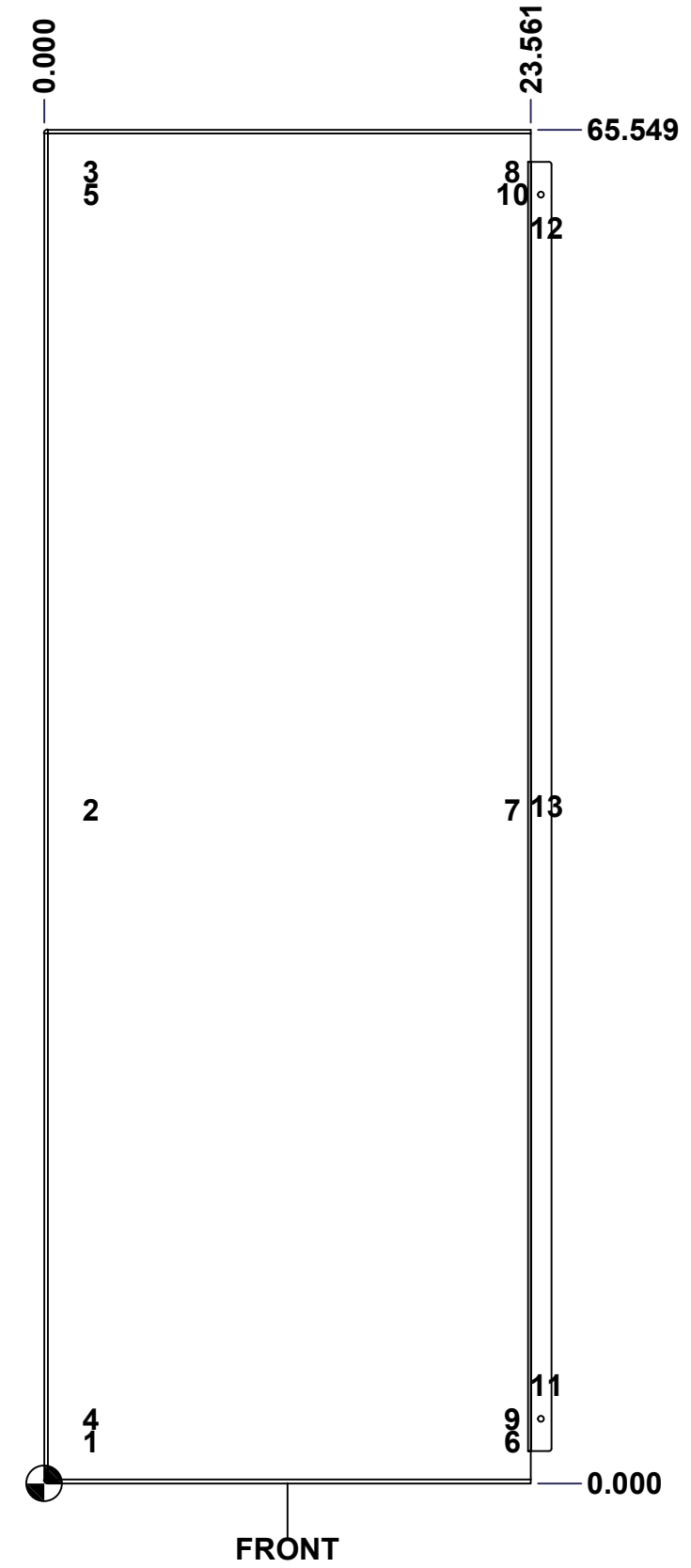

|  |  |                     |
|--|--|---------------------|
|  | Description<br>9500DADD 72" x 48" Front Flange Door    | Status<br>(NULL)    |
|  | Part Number<br>Numéro Pièce<br><b>9500DADD724824FD</b> | Rev. 13<br><b>0</b> |

This drawing is confidential and must not be reproduced or used without the consent of EXM

Ce dessin est confidentiel et ne doit pas être reproduit ou utilisé sans le consentement de EXM

| No. | Revisions | Date | By/Par |
|-----|-----------|------|--------|
|     |           |      |        |
|     |           |      |        |
|     |           |      |        |
|     |           |      |        |
|     |           |      |        |

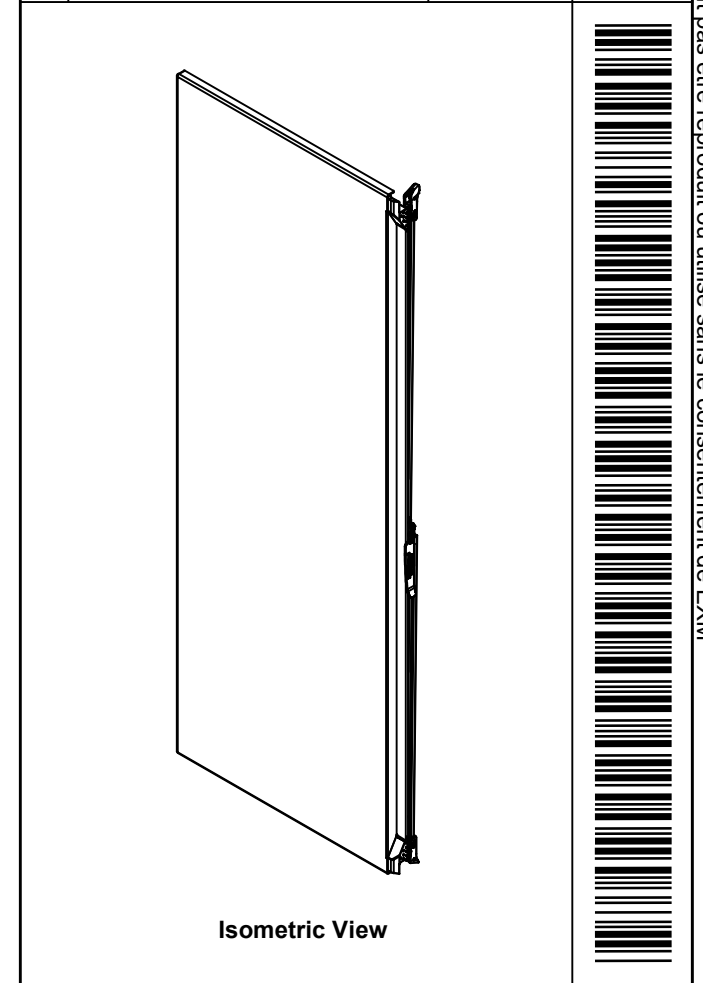

| 1          | STK-P-02400S       | 0   | Powder Paint (Asa-61 Grey / Smooth)           |
|------------|--------------------|-----|---|
| 1          | STK-G-03400        | 1   | 5500 DD Lower Flange Door Gasket              |
| 1          | STK-G-03300        | 2   | 5500 DD Upper Flange Door Gasket              |
| 2          | STK-Q-90045        | 1   | 5500 DDS Flange Door Closing Bar End Assembly |
| 2          | STK-Q-45660-72     | 2   | 9500 DD - Flange Door Closing Bar             |
| 1          | STK-Q-07440        | 0   | M10 Nylon Insert Flanged Lock Nut             |
| 1          | STK-Q-50568        | 1   | Flange Door Handle Spacer                     |
| 1          | STK-A-50556        | 4   | Left Side Flange Door Handle Assembly         |
| 1          | STK-K-20830        | 4   | 9500 - Flange Door Stiffener Assembly         |
| 1          | STK-Q-15005        | 0   | Stud M10 x 25mm                               |
| 2          | STK-Q-16405        | 7   | Guide Stud - Small (No Paint Cap Required)    |
| 10         | STK-Q-16055        | 1   | M6 x 18mm Stud (No Paint Cap Required)        |
| 1          | STK-G-00701        | 0   | 1" x 1/4" Self-Adhesive Neoprene Gasket       |
| 1          | 9500DADD724824FDG  | 0   | 9500DADD 72" x 48" Flange Door Gasket         |
| 1          | 9500DADD724824FD-P | 0   | 9500DADD 72" x 48" Front Flange Door Part     |
| 4          | STK-K-09860        | 7   | Cabinet Hinge with Captive Pins               |
| QTY        | Part Number        | Rev | Description                                   |
| Parts List |                    |     |   |

|   |   |                       |
|---|---|-----------------------|
| <p>Tél: (450) 979-4373<br/>Fax: (450) 979-4626<br/><a href="http://www.exmweb.com">www.exmweb.com</a></p> | Flatness<br>Aplatissement                 | Max 3.0mm             |
|   | Projection                                |                       |
| Customer<br>Client  | Date                                      |                       |
| Drawn By<br>Dessiné Par   | BoxCad: BoxCad                            | Date 28-Oct-14        |
| Material<br>Matière   | 12 Ga Cold Rolled A1008 CS Type B (2.5mm) |                       |
| Color<br>Couleur  | Asa-61 Grey                               | Finish<br>Fini Smooth |
| Description   | Detail Rev.                               |                       |
| 9500DADD 72" x 48" Front Flange Door  |   |                       |
| Part Number<br>Numéro Pièce   | Rev. 0                                    | 14 / 21               |
| <b>9500DADD724824FD</b>   |   |                       |

This drawing is confidential and must not be reproduced or used without the consent of EXM

Ce dessin est confidentiel et ne doit pas être reproduit ou utilisé sans le consentement de EXM

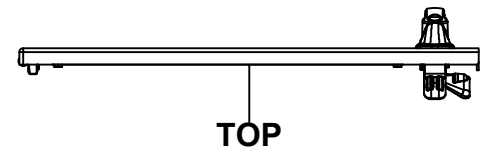

TOP

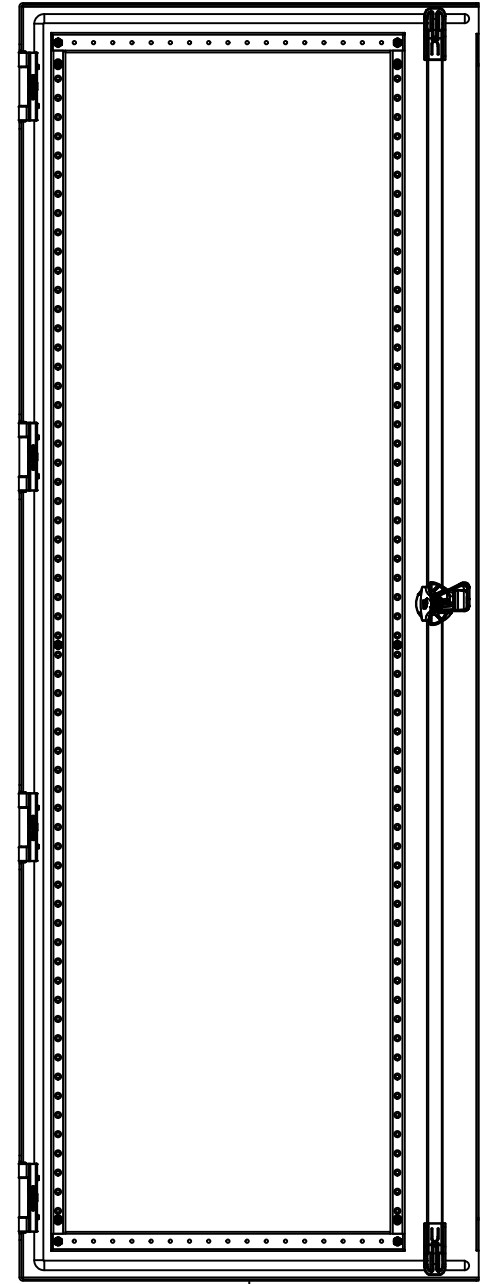

BACK



BOTTOM

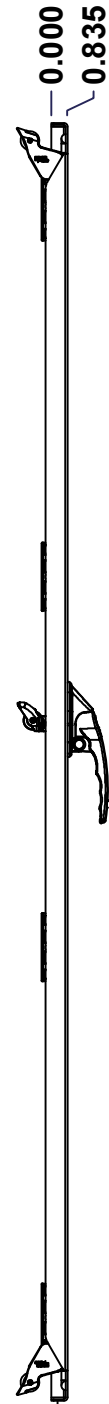

LEFT

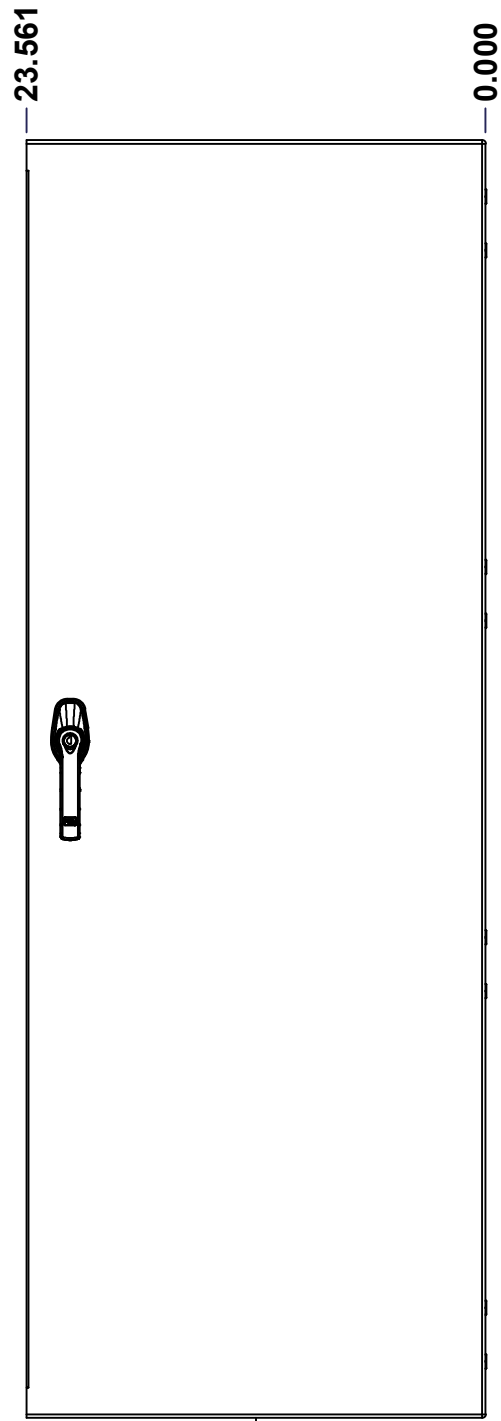

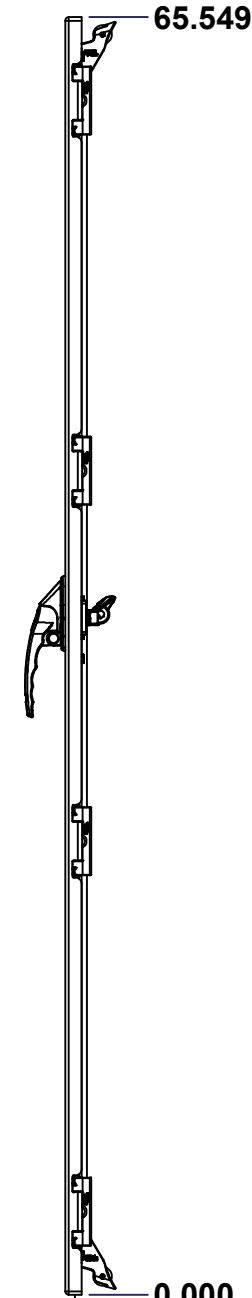

FRONT

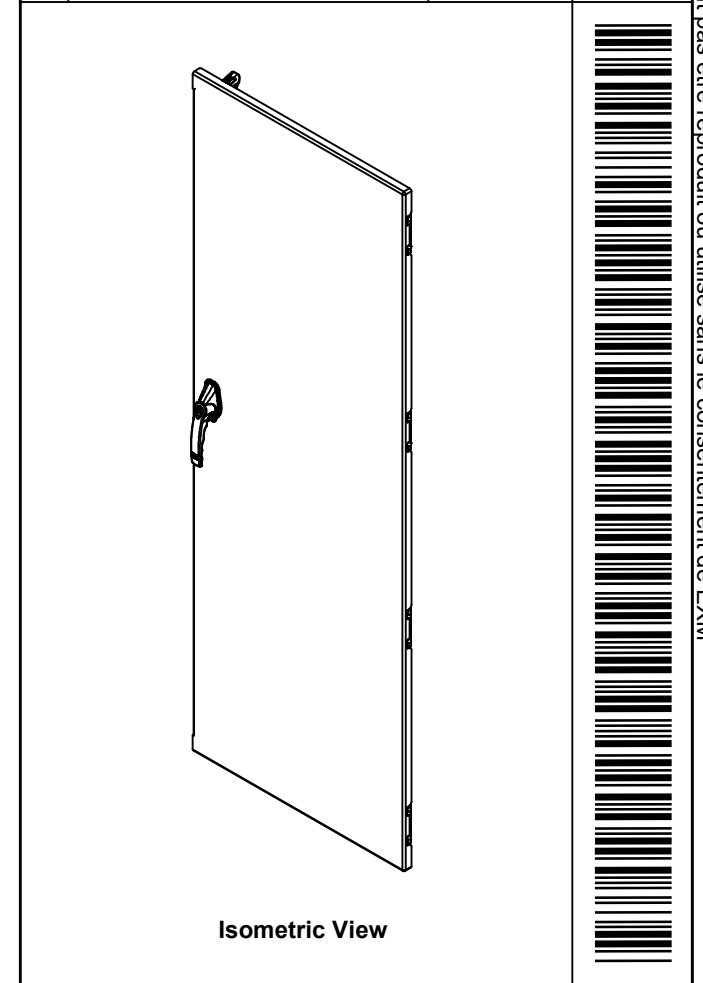

RIGHT

| No. | Revisions | Date | By/Par |
|-----|-----------|------|--------|
|     |           |      |        |
|     |           |      |        |
|     |           |      |        |
|     |           |      |        |
|     |           |      |        |



|  |                       |                           |
|--|-----------------------|---------------------------|
|  Tél: (450) 979-4373<br>Fax: (450) 979-4626<br><a href="http://www.exmweb.com">www.exmweb.com</a> |                       | Flatness<br>Aplatissement |
|  |                       | Max 3.0mm                 |
| Customer<br>Client   |                       | Date                      |
| Drawn By<br>Dessiné Par BoxCad: BoxCad   |                       | Date 28-Oct-14            |
| Material<br>Matière 12 Ga Cold Rolled A1008 CS Type B (2.5mm)  |                       |                           |
| Color<br>Couleur Asa-61 Grey   | Finish<br>Fini Smooth |                           |
| Description<br>9500DADD 72" x 48" Back Lock Door   |                       | Detail Rev.               |
| Part Number<br>Numéro Pièce <b>9500DADD724824LB</b>  | Rev. <b>0</b>         | 15<br>21                  |

SEE BILL OF MATERIAL ON LAST PAGE

This drawing is confidential and must not be reproduced or used without the consent of EXM

Ce dessin est confidentiel et ne doit pas être reproduit ou utilisé sans le consentement de EXM

**STANDARD FEATURES ARE NOT LISTED IN THIS HOLE TABLE**

**HOLE TABLE - FRONT VIEW (CUSTOM FEATURE ONLY)**

| CUT-OUT | XDIM   | YDIM   | DESCRIPTION                  |
|---------|--------|--------|------------------------------|
| 1       | 1.983  | 2.028  | STUD M6 x 18mm (Inside)      |
| 2       | 1.983  | 32.628 | STUD M6 x 18mm (Inside)      |
| 3       | 1.983  | 63.521 | STUD M6 x 18mm (Inside)      |
| 4       | 1.983  | 3.139  | STUD M6 x 18mm (Inside)      |
| 5       | 1.983  | 62.409 | STUD M6 x 18mm (Inside)      |
| 6       | 19.390 | 2.028  | STUD M6 x 18mm (Inside)      |
| 7       | 19.390 | 32.628 | STUD M6 x 18mm (Inside)      |
| 8       | 19.390 | 63.521 | STUD M6 x 18mm (Inside)      |
| 9       | 19.390 | 3.139  | STUD M6 x 18mm (Inside)      |
| 10      | 19.390 | 62.409 | STUD M6 x 18mm (Inside)      |
| 11      | 21.311 | 6.118  | LARGE CBAR GUIDE (Inside)    |
| 12      | 21.311 | 59.430 | LARGE CBAR GUIDE (Inside)    |
| -----   | -----  | -----  | -----                        |
| 13      | 21.311 | 34.743 | HANDLE 885 ESL2A-APHK @ 0.0° |

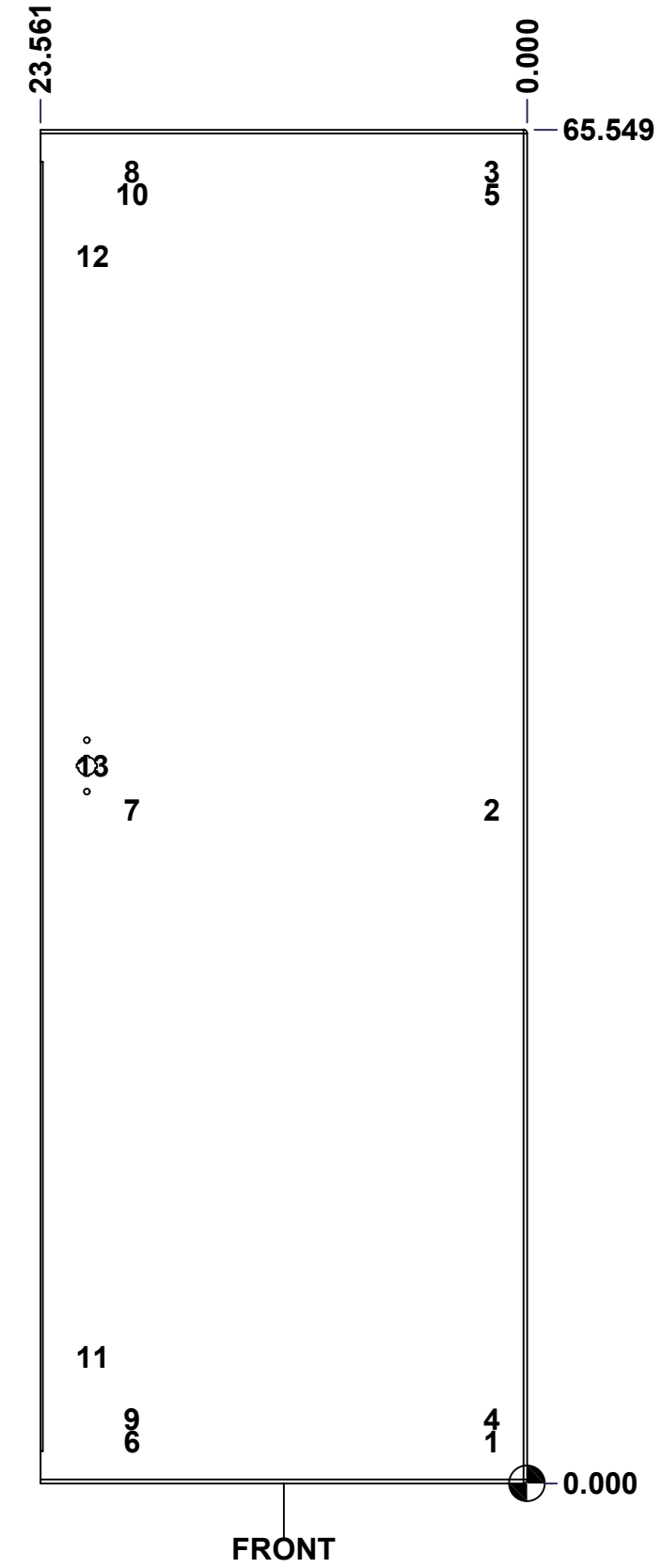

|  |                                   |          |
|--|-----------------------------------|----------|
|  | Description                       | Status   |
|  | 9500DADD 72" x 48" Back Lock Door | (NULL)   |
|  | Part Number                       | Rev.     |
|  | Numéro Pièce                      | 16       |
|  | <b>9500DADD724824LB</b>           | <b>0</b> |
|  |                                   | 21       |

This drawing is confidential and must not be reproduced or used without the consent of EXM

Ce dessin est confidentiel et ne doit pas être reproduit ou utilisé sans le consentement de EXM

| No. | Revisions | Date | By/Par |
|-----|-----------|------|--------|
|     |           |      |        |
|     |           |      |        |
|     |           |      |        |
|     |           |      |        |
|     |           |      |        |

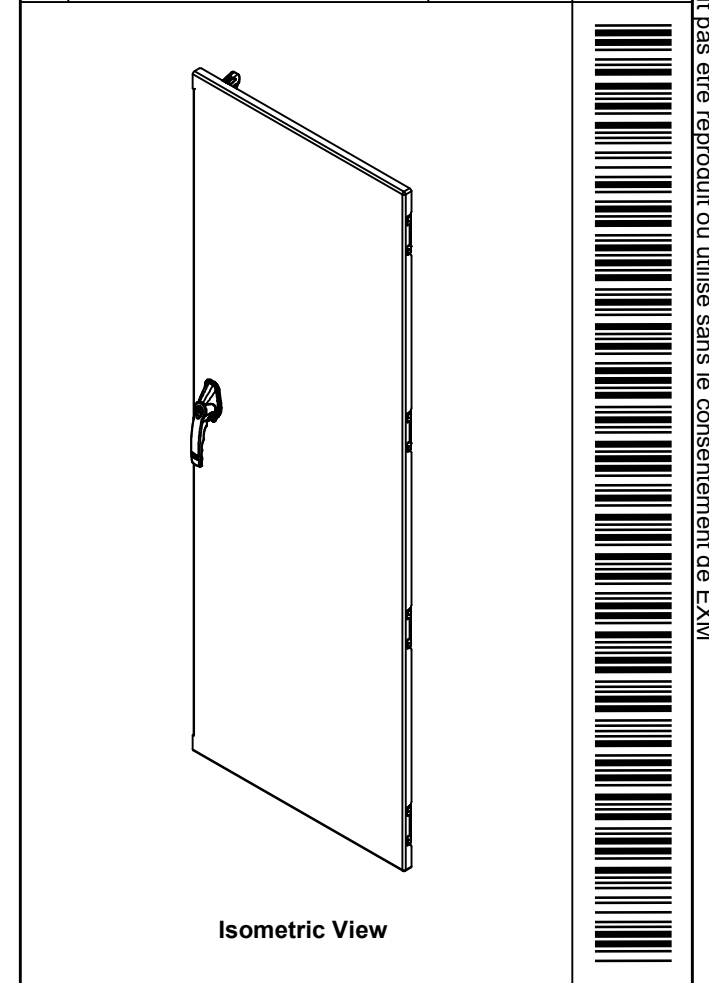

|    |                    |   |  |
|----|--------------------|---|--|
| 1  | STK-Q-47562        | 0 | 9500 Lower Closing Bar 72" (cam)                         |
| 1  | STK-Q-47552        | 0 | 9500 Upper Closing Bar 72" (cam)                         |
| 1  | STK-A-50537        | 3 | 9500 Handle Cam Assembly (Left Side, Grip 36mm)          |
| 1  | STK-Q-90051        | 3 | 5412 ES - Handle Cam Spacer                              |
| 1  | 885ESL2A-APHK      | 7 | 885 ESL2A-APHK - Zinc Die Cast L-Handle Padlockable Assy |
| 1  | STK-P-02400S       | 0 | Powder Paint (Asa-61 Grey / Smooth)                      |
| 1  | STK-K-10830        | 3 | 9500 - Door Stiffener Assembly                           |
| 2  | STK-Q-16410        | 0 | Guide Stud - Largel (No Paint Cap Required)              |
| 10 | STK-Q-16055        | 1 | M6 x 18mm Stud (No Paint Cap Required)                   |
| 1  | 9500DADD724824LDG  | 0 | 9500DADD 72" x 48" Lock Door Gasket                      |
| 1  | 9500DADD724824LB-P | 0 | 9500DADD 72" x 48" Back Lock Door Part                   |
| 2  | STK-A-90025        | 0 | 9500 - Cabinet Closing Bar End (Large)                   |
| 4  | STK-K-09860        | 7 | Cabinet Hinge with Captive Pins                          |
| 2  | STK-Q-07220        | 1 | M6 Nylon Insert Lock Nut                                 |

| QTY        | Part Number | Rev | Description |
|------------|-------------|-----|-------------|
| Parts List |             |     |             |

|  |  |  |
|--|--|--|
|  | Tél: (450) 979-4373<br>Fax: (450) 979-4626<br><a href="http://www.exmweb.com">www.exmweb.com</a> | Flatness<br>Aplatissement<br>Max 3.0mm                           |
|  | Projection<br>   | Customer<br>Client   |
| Drawn By<br>Dessiné Par<br>BoxCad: BoxCad              | Date<br>28-Oct-14  | Material<br>Matière<br>12 Ga Cold Rolled A1008 CS Type B (2.5mm) |
| Color<br>Couleur<br>Asa-61 Grey                        | Finish<br>Fini<br>Smooth   | Description<br>9500DADD 72" x 48" Back Lock Door                 |
| Part Number<br>Numéro Pièce<br><b>9500DADD724824LB</b> | Rev.<br><b>0</b>   | Detail Rev.<br>17 / 21   |

This drawing is confidential and must not be reproduced or used without the consent of EXM

Ce dessin est confidentiel et ne doit pas être reproduit ou utilisé sans le consentement de EXM



TOP

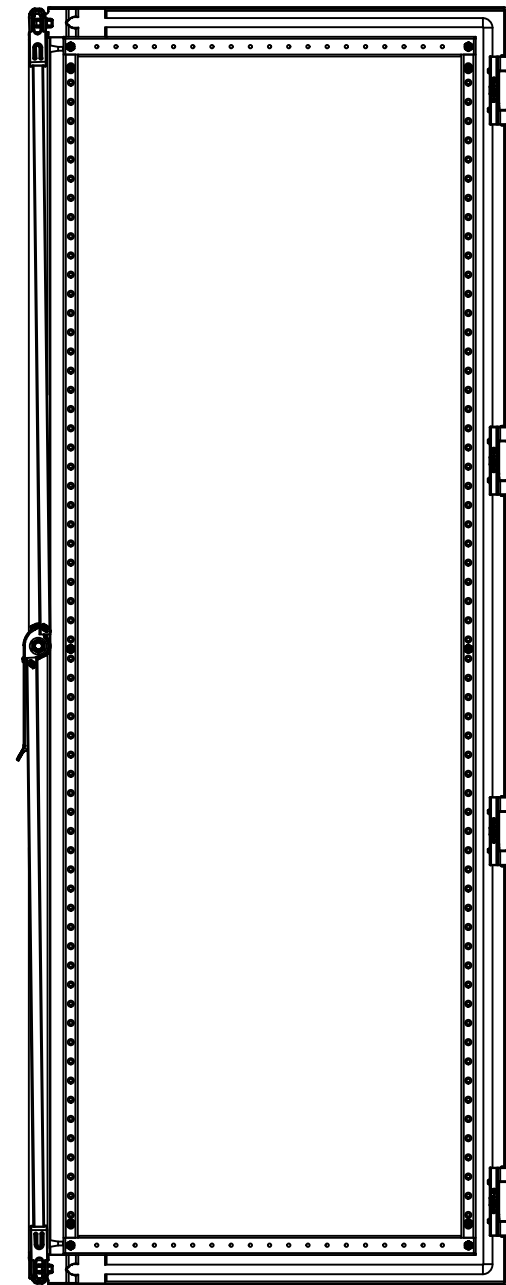

BACK

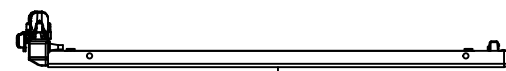

BOTTOM

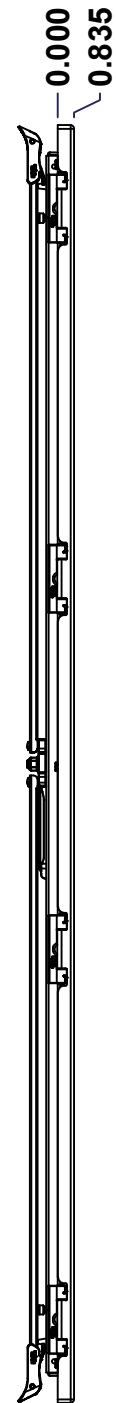

LEFT

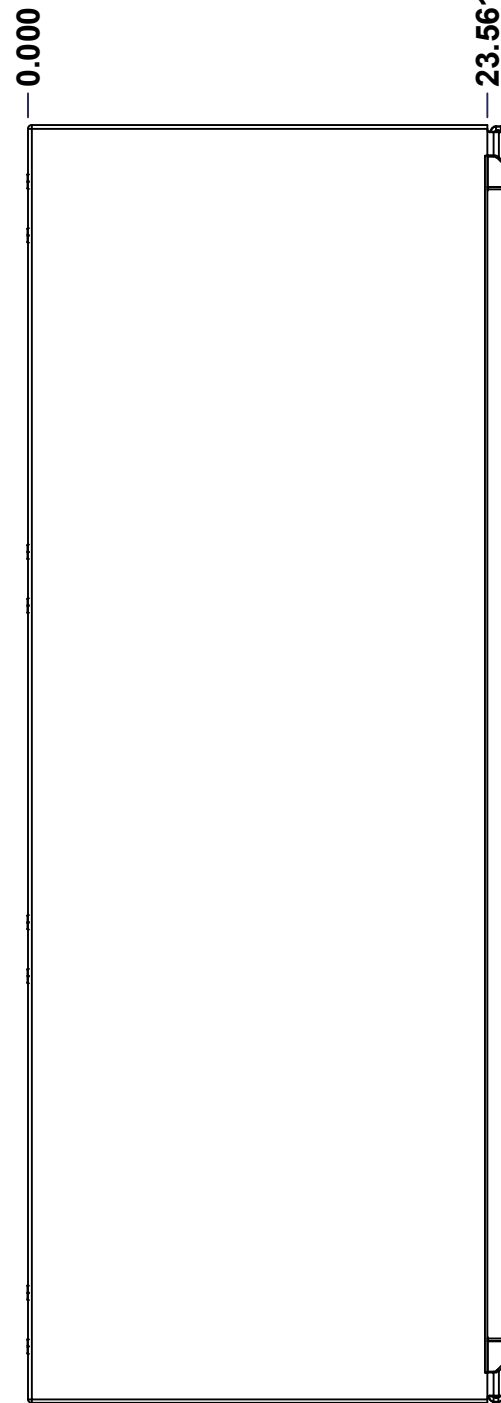

FRONT

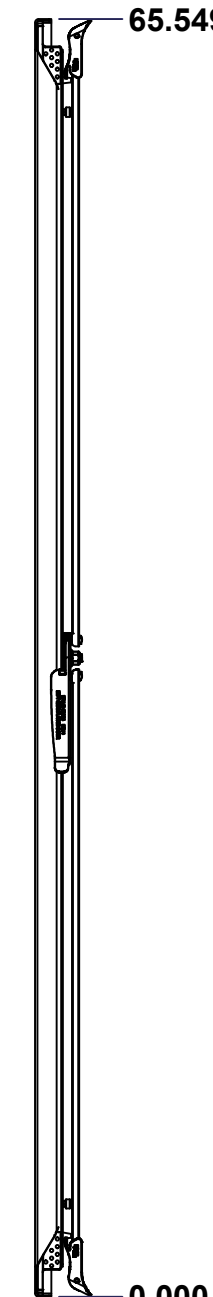

RIGHT

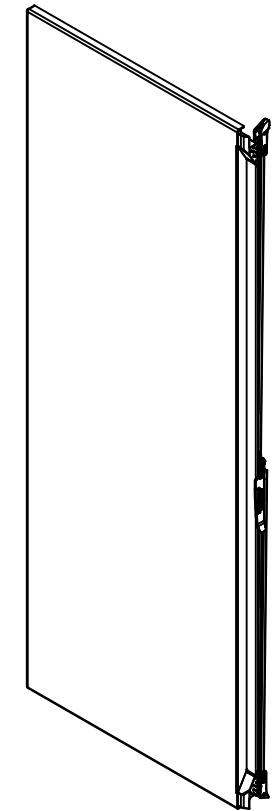

Isometric View

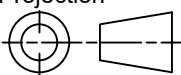

| No. | Revisions | Date | By/Par |
|-----|-----------|------|--------|
|     |           |      |        |
|     |           |      |        |
|     |           |      |        |
|     |           |      |        |
|     |           |      |        |

|  |   |   |
|--|---|---|
|  Tél: (450) 979-4373<br>Fax: (450) 979-4626<br><a href="http://www.exmweb.com">www.exmweb.com</a> |   | Flatness<br>Aplatissement<br>Max 3.0mm<br>Projection<br> |
| Customer Client  | Date                                      |   |
| Drawn By<br>Dessiné Par  | BoxCad: BoxCad                            | Date 28-Oct-14  |
| Material<br>Matière  | 12 Ga Cold Rolled A1008 CS Type B (2.5mm) |   |
| Color<br>Couleur   | Asa-61 Grey                               | Finish<br>Fini Smooth   |
| Description<br>9500DADD 72" x 48" Back Flange Door   |   | Detail Rev.   |
| Part Number<br>Numéro Pièce  | Rev. 0                                    | 18 / 21   |

SEE BILL OF MATERIAL ON LAST PAGE

**9500DADD724824FB**

This drawing is confidential and must not be reproduced or used without the consent of EXM

Ce dessin est confidentiel et ne doit pas être reproduit ou utilisé sans le consentement de EXM

**STANDARD FEATURES ARE NOT LISTED IN THIS HOLE TABLE**

**HOLE TABLE - FRONT VIEW (CUSTOM FEATURE ONLY)**

| CUT-OUT | XDIM   | YDIM   | DESCRIPTION               |
|---------|--------|--------|---------------------------|
| 1       | 2.000  | 2.028  | STUD M6 x 18mm (Inside)   |
| 2       | 2.000  | 32.628 | STUD M6 x 18mm (Inside)   |
| 3       | 2.000  | 63.521 | STUD M6 x 18mm (Inside)   |
| 4       | 2.000  | 3.139  | STUD M6 x 18mm (Inside)   |
| 5       | 2.000  | 62.409 | STUD M6 x 18mm (Inside)   |
| 6       | 22.407 | 2.028  | STUD M6 x 18mm (Inside)   |
| 7       | 22.407 | 32.628 | STUD M6 x 18mm (Inside)   |
| 8       | 22.407 | 63.521 | STUD M6 x 18mm (Inside)   |
| 9       | 22.407 | 3.139  | STUD M6 x 18mm (Inside)   |
| 10      | 22.407 | 62.409 | STUD M6 x 18mm (Inside)   |
| 11      | 24.061 | 4.774  | SMALL CBAR GUIDE (Inside) |
| 12      | 24.061 | 60.774 | SMALL CBAR GUIDE (Inside) |
| 13      | 24.061 | 32.774 | STUD M10 x 20mm (Inside)  |

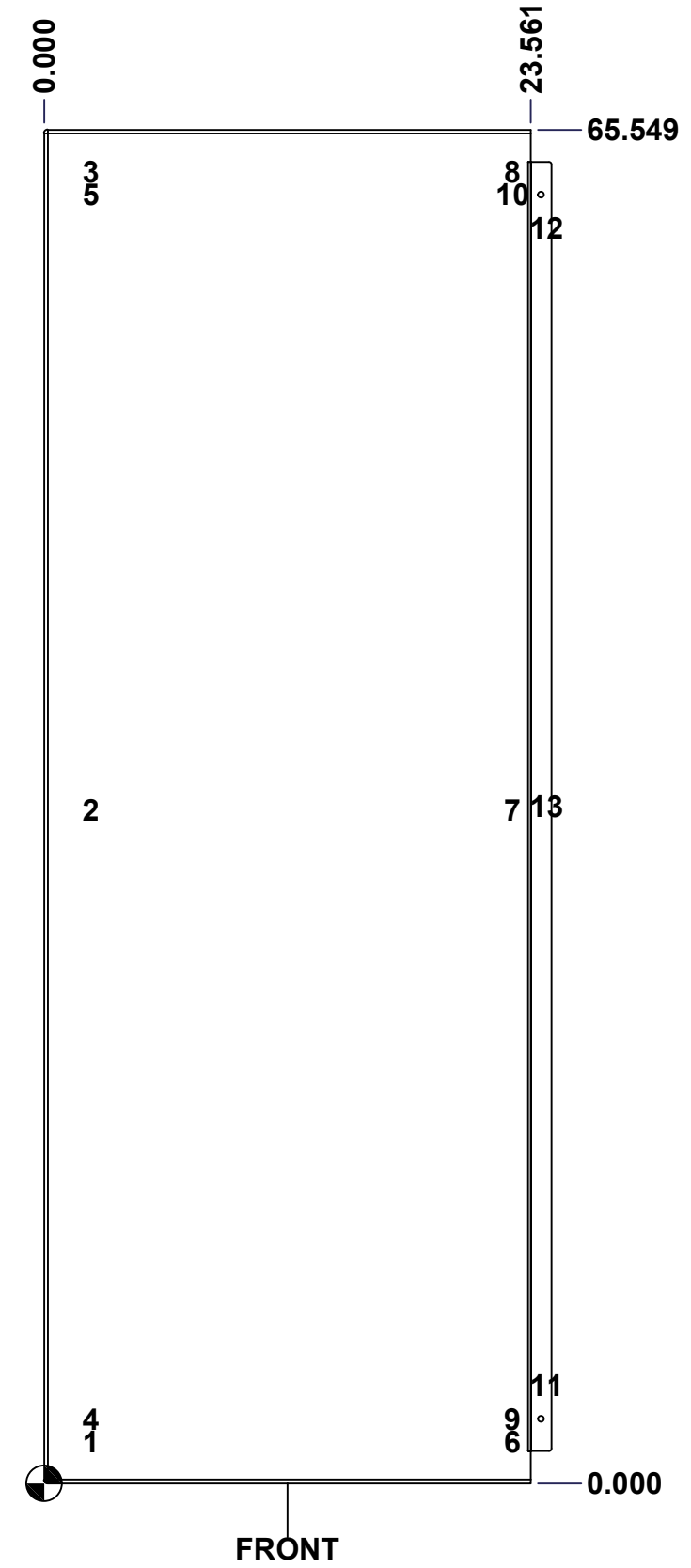

|  |  |                        |
|--|--|------------------------|
|  | Description<br>9500DADD 72" x 48" Back Flange Door     | Status<br>(NULL)       |
|  | Part Number<br>Numéro Pièce<br><b>9500DADD724824FB</b> | Rev. 19<br><b>0</b> 21 |

This drawing is confidential and must not be reproduced or used without the consent of EXM

Ce dessin est confidentiel et ne doit pas être reproduit ou utilisé sans le consentement de EXM

| No. | Revisions | Date | By/Par |
|-----|-----------|------|--------|
|     |           |      |        |
|     |           |      |        |
|     |           |      |        |
|     |           |      |        |
|     |           |      |        |

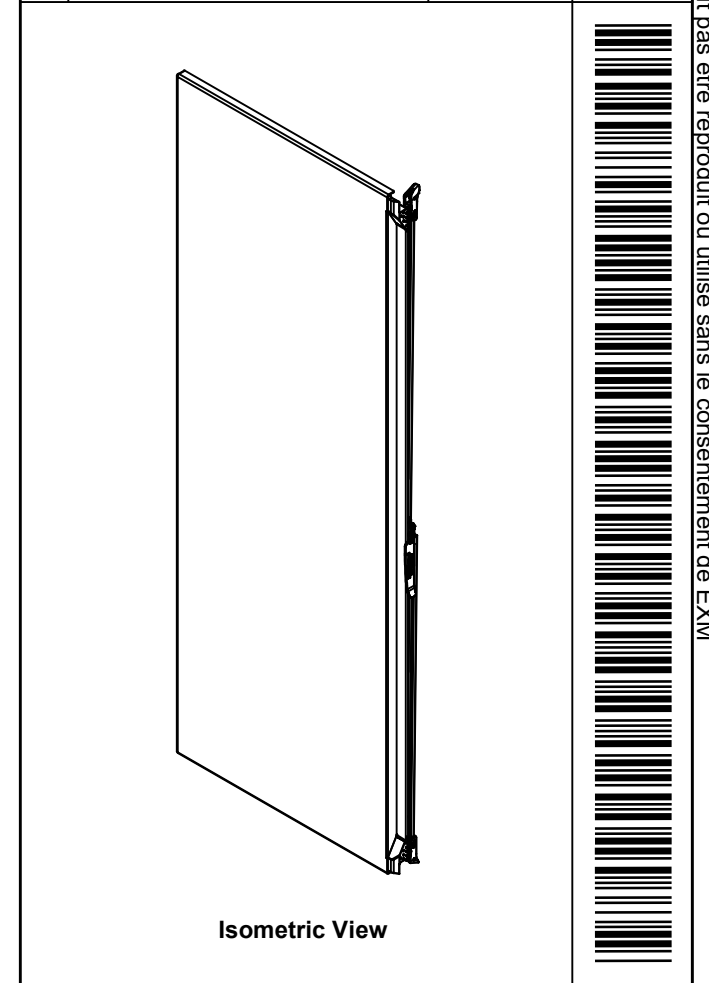

| 1          | STK-P-02400S       | 0   | Powder Paint (Asa-61 Grey / Smooth)           |
|------------|--------------------|-----|---|
| 1          | STK-G-03400        | 1   | 5500 DD Lower Flange Door Gasket              |
| 1          | STK-G-03300        | 2   | 5500 DD Upper Flange Door Gasket              |
| 2          | STK-Q-90045        | 1   | 5500 DDS Flange Door Closing Bar End Assembly |
| 2          | STK-Q-45660-72     | 2   | 9500 DD - Flange Door Closing Bar             |
| 1          | STK-Q-07440        | 0   | M10 Nylon Insert Flanged Lock Nut             |
| 1          | STK-Q-50568        | 1   | Flange Door Handle Spacer                     |
| 1          | STK-A-50556        | 4   | Left Side Flange Door Handle Assembly         |
| 1          | STK-K-20830        | 4   | 9500 - Flange Door Stiffener Assembly         |
| 1          | STK-Q-15005        | 0   | Stud M10 x 25mm                               |
| 2          | STK-Q-16405        | 7   | Guide Stud - Small (No Paint Cap Required)    |
| 10         | STK-Q-16055        | 1   | M6 x 18mm Stud (No Paint Cap Required)        |
| 1          | STK-G-00701        | 0   | 1" x 1/4" Self-Adhesive Neoprene Gasket       |
| 1          | 9500DADD724824FDG  | 0   | 9500DADD 72" x 48" Flange Door Gasket         |
| 1          | 9500DADD724824FB-P | 0   | 9500DADD 72" x 48" Back Flange Door Part      |
| 4          | STK-K-09860        | 7   | Cabinet Hinge with Captive Pins               |
| QTY        | Part Number        | Rev | Description                                   |
| Parts List |                    |     |   |

|   |   |                       |
|---|---|-----------------------|
| <p>Tél: (450) 979-4373<br/>Fax: (450) 979-4626<br/><a href="http://www.exmweb.com">www.exmweb.com</a></p> | Flatness<br>Aplatissement                 | Max 3.0mm             |
|   | Projection                                |                       |
| Customer<br>Client  | Date                                      |                       |
| Drawn By<br>Dessiné Par   | BoxCad: BoxCad                            | Date 28-Oct-14        |
| Material<br>Matière   | 12 Ga Cold Rolled A1008 CS Type B (2.5mm) |                       |
| Color<br>Couleur  | Asa-61 Grey                               | Finish<br>Fini Smooth |
| Description   | Detail Rev.                               |                       |
| 9500DADD 72" x 48" Back Flange Door   |   |                       |
| Part Number<br>Numéro Pièce   | Rev. 0                                    | 20<br>21              |
| <b>9500DADD724824FB</b>   |   |                       |

All knockouts are actual size / Les disques défonçables sont grandeur réel  
 All dimensions are before paint / Toutes les dimensions sont avant peinture

This drawing is confidential and must not be reproduced or used without the consent of EXM

Ce dessin est confidentiel et ne doit pas être reproduit ou utilisé sans le consentement de EXM

**Lifting angles welded**

**Weld inside of struts with the enclosure corner on both ends**

**Full depth struts length**

**Struts sits On two studs**

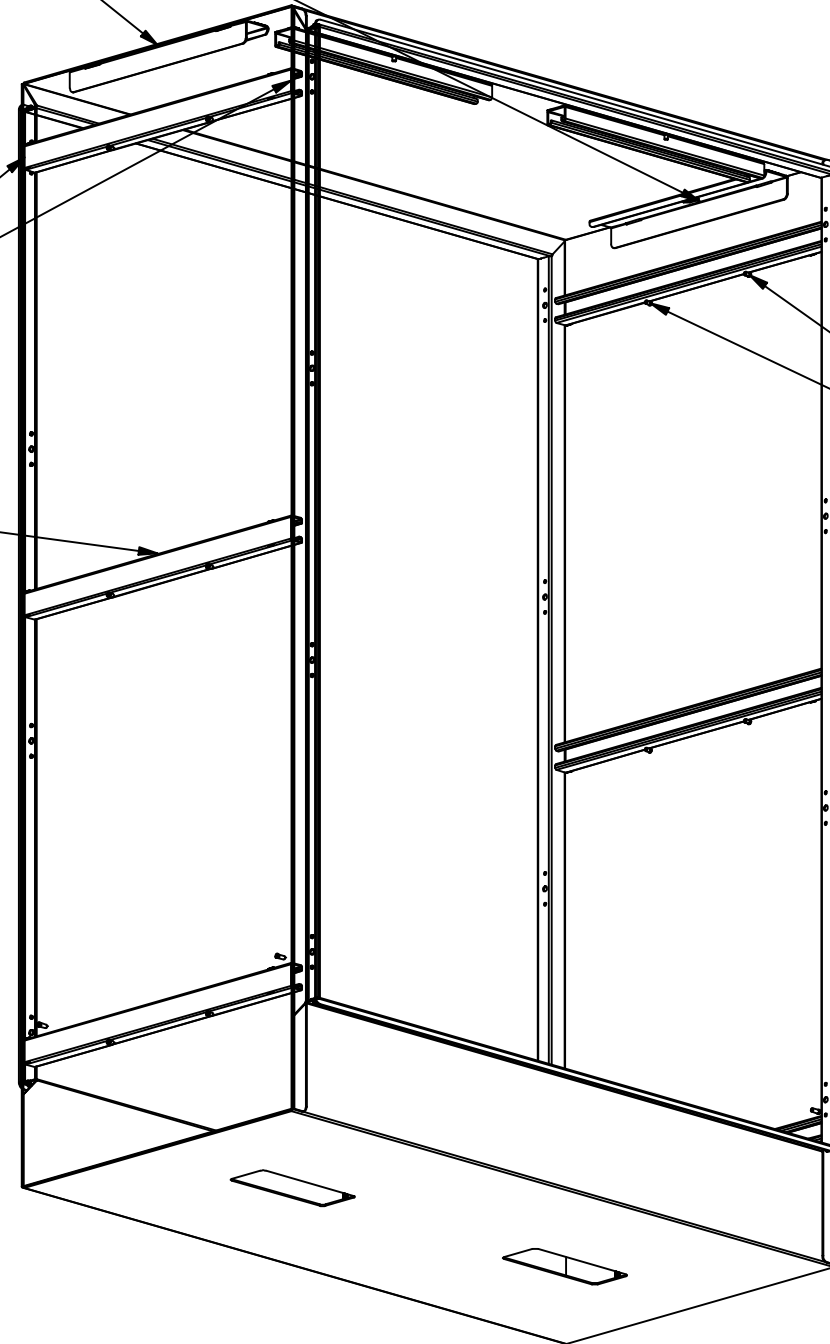

| No. | Revisions | Date | By/Par |
|-----|-----------|------|--------|
|     |           |      |        |
|     |           |      |        |
|     |           |      |        |
|     |           |      |        |

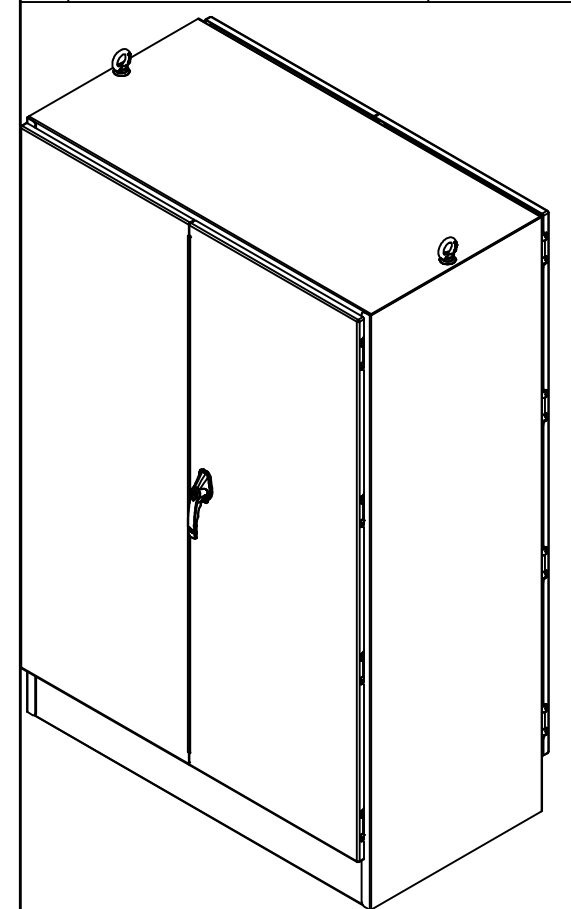

Isometric View

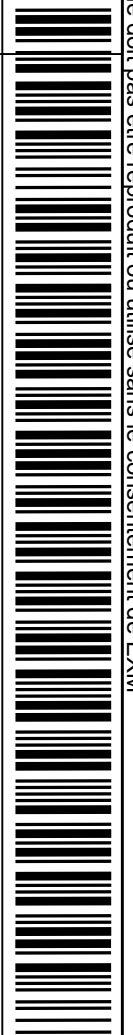

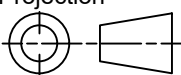
|  |   |   |
|--|---|---|
|  Tél: (450) 979-4373<br>Fax: (450) 979-4626<br><a href="http://www.exmweb.com">www.exmweb.com</a> |   | Flatness<br>Aplatissement<br>Max 3.0mm<br>Projection<br> |
| Customer Client  | Date                                      |   |
| Drawn By<br>Dessiné Par  | BoxCad                                    | Date 11-Aug-05  |
| Material<br>Matière  | 12 Ga Cold Rolled A1008 CS Type B (2.5mm) |   |
| Color<br>Couleur   | Asa-61 Grey                               | Finish<br>Fini Smooth   |
| Description<br>9500DADD 72" x 48" x 24" Assembly   |   | Detail Rev.   |
| Part Number<br>Numéro Pièce  | 9500DADD Welding Details                  | Rev. 21<br><b>0</b> 21  |