

This drawing is confidential and must not be reproduced or used without the consent of EXM

Ce dessin est confidentiel et ne doit pas être reproduit ou utilisé sans le consentement de EXM

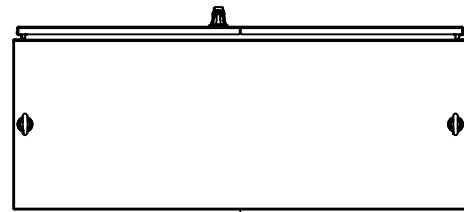

TOP



BACK

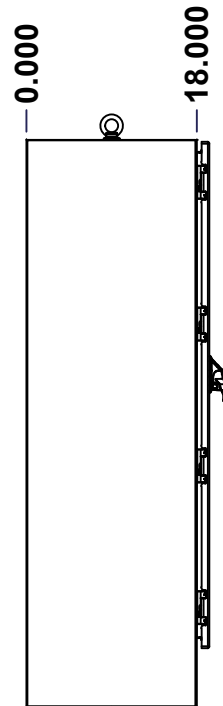

LEFT

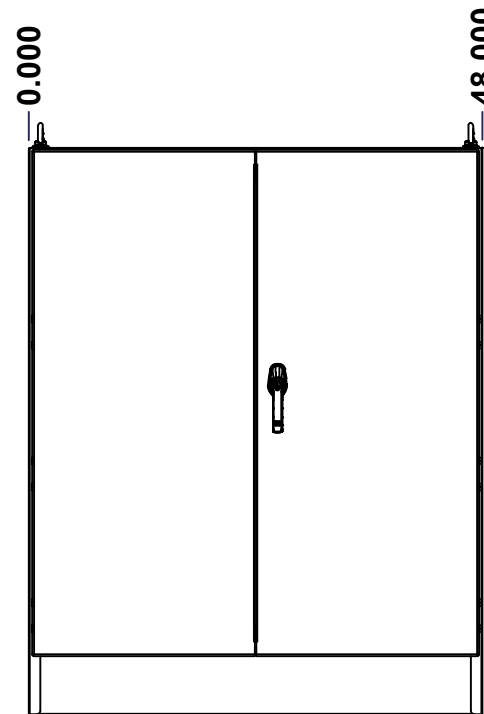

FRONT

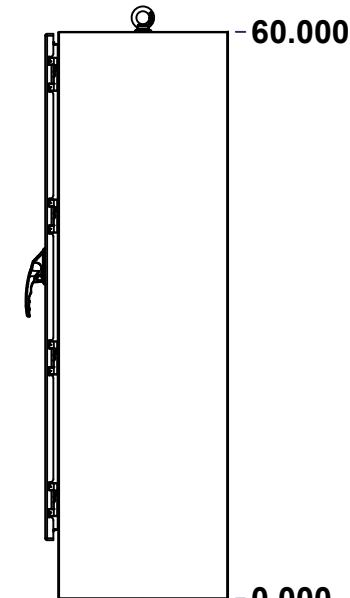

RIGHT

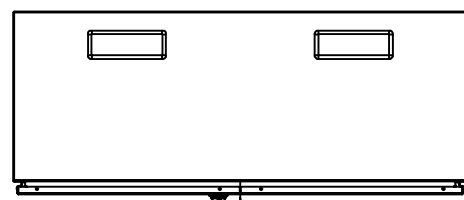

BOTTOM

No.	Revisions	Date	By/Par

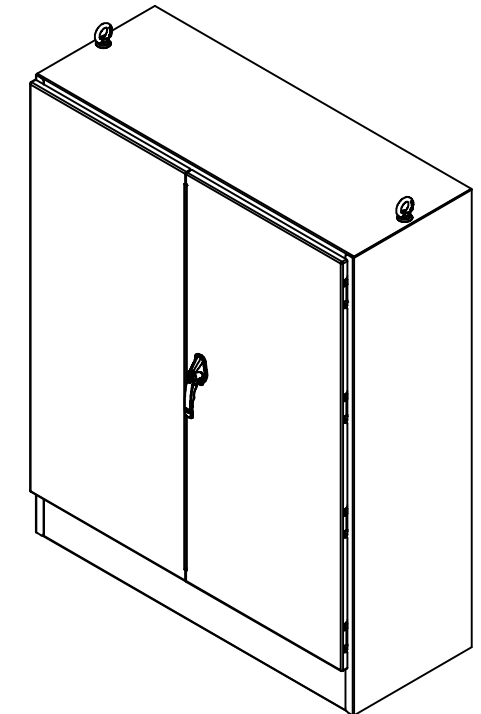

Isometric View



Tél: (450) 979-4373  
 Fax: (450) 979-4626  
[www.exmweb.com](http://www.exmweb.com)

Flatness  
Aplatissement

Max 3.0mm

Projection

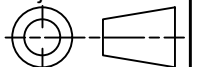

Customer Client	Date
Drawn By Dessiné Par BoxCad: BoxCad	Date 20-Dec-13
Material Matière 12 Ga Cold Rolled A1008 CS Type B (2.5mm)	
Color Couleur Asa-61 Grey	Finish Fini Smooth
Description 9500DD 60" x 48" x 18" Assembly	Detail Rev.
Part Number Numéro Pièce <b>9500DD604818</b>	Rev. <b>0</b>

SEE BILL OF MATERIAL ON LAST PAGE

This drawing is confidential and must not be reproduced or used without the consent of EXM

Ce dessin est confidentiel et ne doit pas être reproduit ou utilisé sans le consentement de EXM

NOTE	
ITEM	DESCRIPTION
1	NEMA 12, 13 Enclosure (IP55)
2	C/W Standard ground studs on box and cover
3	C/W Standard door stiffener
4	W/O Inner panel
5	C/W Standard inner panel mounting struts
6	C/W Eyebolts sold separately (Installed by EXM)
7	C/W Struts installed (Included)

No.	Revisions	Date	By/Par

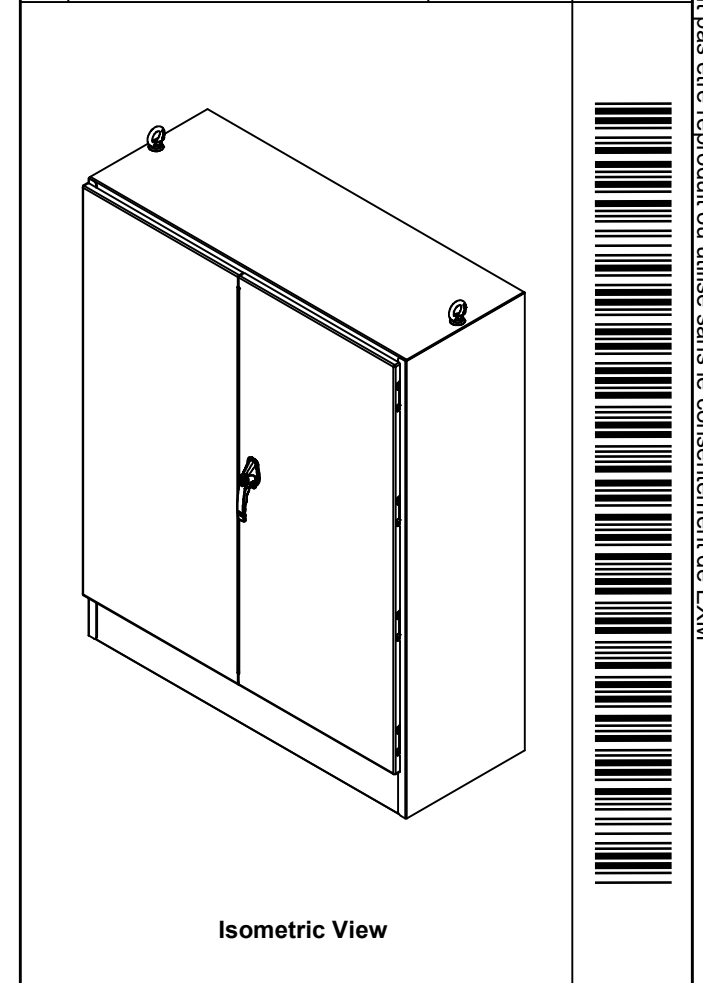

PACKING		
ITEM	QTY	DESCRIPTION
Cardboard sleeve	2	Top and Bottom
Cardboard strip	2	Between back of enclosure and inner panel
Plastic bag	1	To protect cover surface and inside gasket
Cardboard corner	4	To reinforced for the plastic strap tightening
Plastic strap - Black	2	To Squeeze 2 cardboard sleeve together
Packaging label	3	White label with PN
Plastic strap- Green	2	To secure the enclosure to the wood pallet
Wood Pallet	1	2" deeper and 3" larger than enclosure size

1	880EB14	2	Eye Bolt M14 (Pack of 2)
1	889BPS	0	Inner Panel Strut Mounting Kit
1	9500DD604818FD	0	9500DD 60" x 48" Flange Door
1	9500DD604818LD	0	9500DD 60" x 48" Lock Door
1	9500DD604818B	0	9500DD 60" x 48" x 18" Body
2	9500DD604818GP	0	9500DD Gland Plate
8	STK-Q-04050-10	8	M6 x 10mm Hexagon Socket Head Machine Screw with Nyseal
Qty	Part Number	Rev	Description
Parts List			

	Tél: (450) 979-4373 Fax: (450) 979-4626 <a href="http://www.exmweb.com">www.exmweb.com</a>	Flatness Aplatissement Max 3.0mm
	Projection	
Customer Client	Date	
Drawn By Dessiné Par	BoxCad: BoxCad	Date 20-Dec-13
Material Matière	12 Ga Cold Rolled A1008 CS Type B (2.5mm)	
Color Couleur	Asa-61 Grey	Finish Fini Smooth
Description	9500DD 60" x 48" x 18" Assembly	
Part Number Numéro Pièce	9500DD604818	Detail Rev. 2
	Rev. 0	15

This drawing is confidential and must not be reproduced or used without the consent of EXM

Ce dessin est confidentiel et ne doit pas être reproduit ou utilisé sans le consentement de EXM

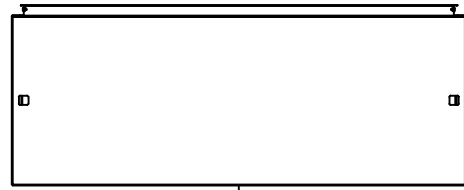

TOP

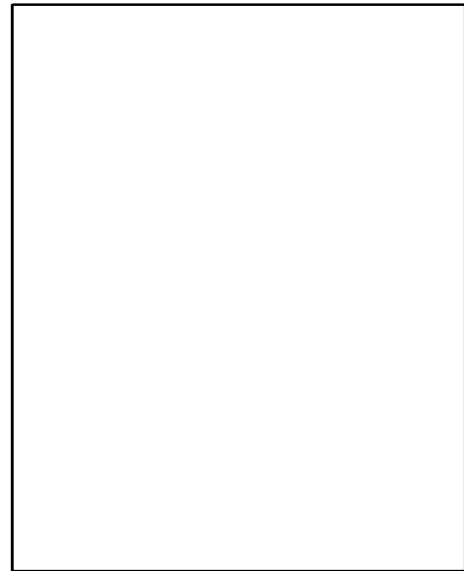

BACK

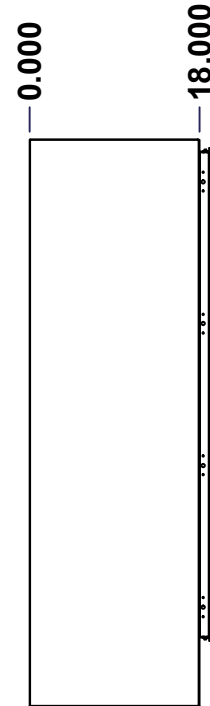

LEFT

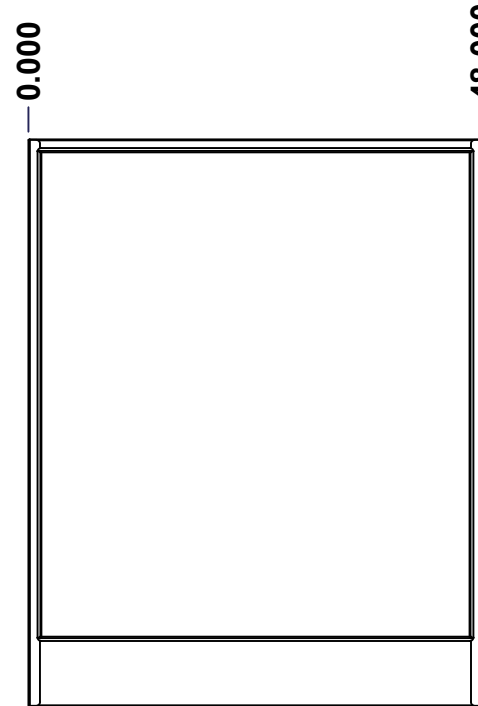

FRONT

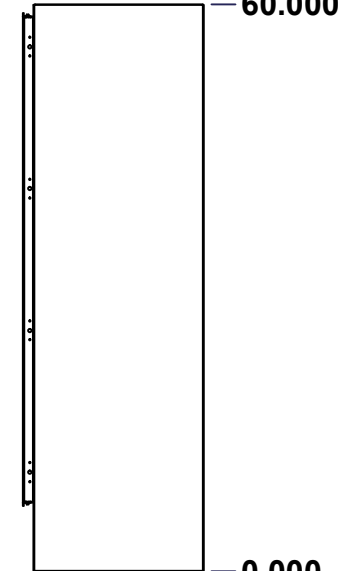

RIGHT

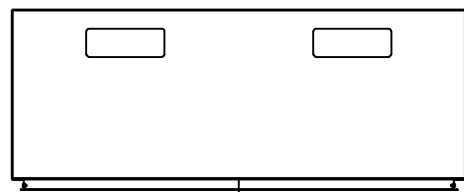

BOTTOM

No.	Revisions	Date	By/Par

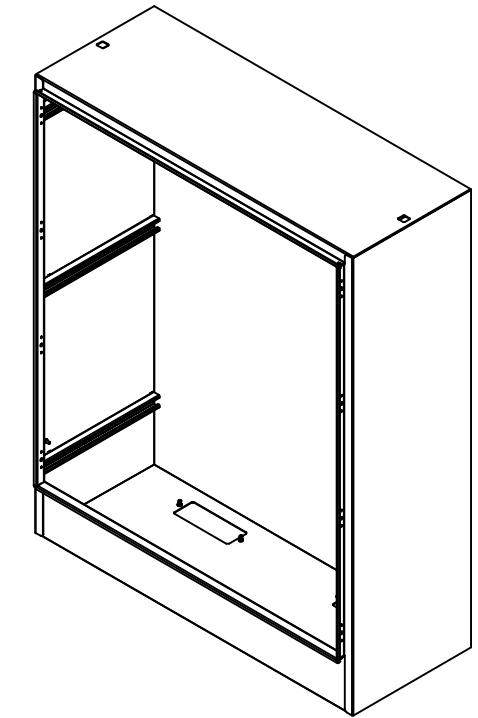

Isometric View



Tél: (450) 979-4373  
 Fax: (450) 979-4626  
[www.exmweb.com](http://www.exmweb.com)

Flatness  
Aplatissement

Max 3.0mm

Projection

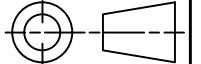

Customer Client	Date
Drawn By / Dessiné Par: BoxCad: BoxCad	Date: 20-Dec-13
Material / Matière: 12 Ga Cold Rolled A1008 CS Type B (2.5mm)	

Color / Couleur: Asa-61 Grey	Finish / Fini: Smooth
------------------------------	-----------------------

Description: 9500DD 60" x 48" x 18" Body	Detail Rev.
--	-------------

Part Number / Numéro Pièce: 9500DD604818B	Rev. 0	3
---	--------	---

SEE BILL OF MATERIAL ON LAST PAGE

This drawing is confidential and must not be reproduced or used without the consent of EXM

Ce dessin est confidentiel et ne doit pas être reproduit ou utilisé sans le consentement de EXM

**STANDARD FEATURES ARE NOT LISTED IN THIS HOLE TABLE**

**HOLE TABLE - TOP VIEW (CUSTOM FEATURE ONLY)**

CUT-OUT	XDIM	YDIM	DESCRIPTION
1	11.911	13.911	Struts CR400 17.500" (Inside)
2	35.911	13.911	Struts CR400 17.500" (Inside)
3	11.911	14.840	STUDS M6 x 10mm (Inside)
4	20.777	13.911	STUDS M6 x 10mm (Inside)
5	35.911	14.840	STUDS M6 x 10mm (Inside)
6	44.777	13.911	STUDS M6 x 10mm (Inside)

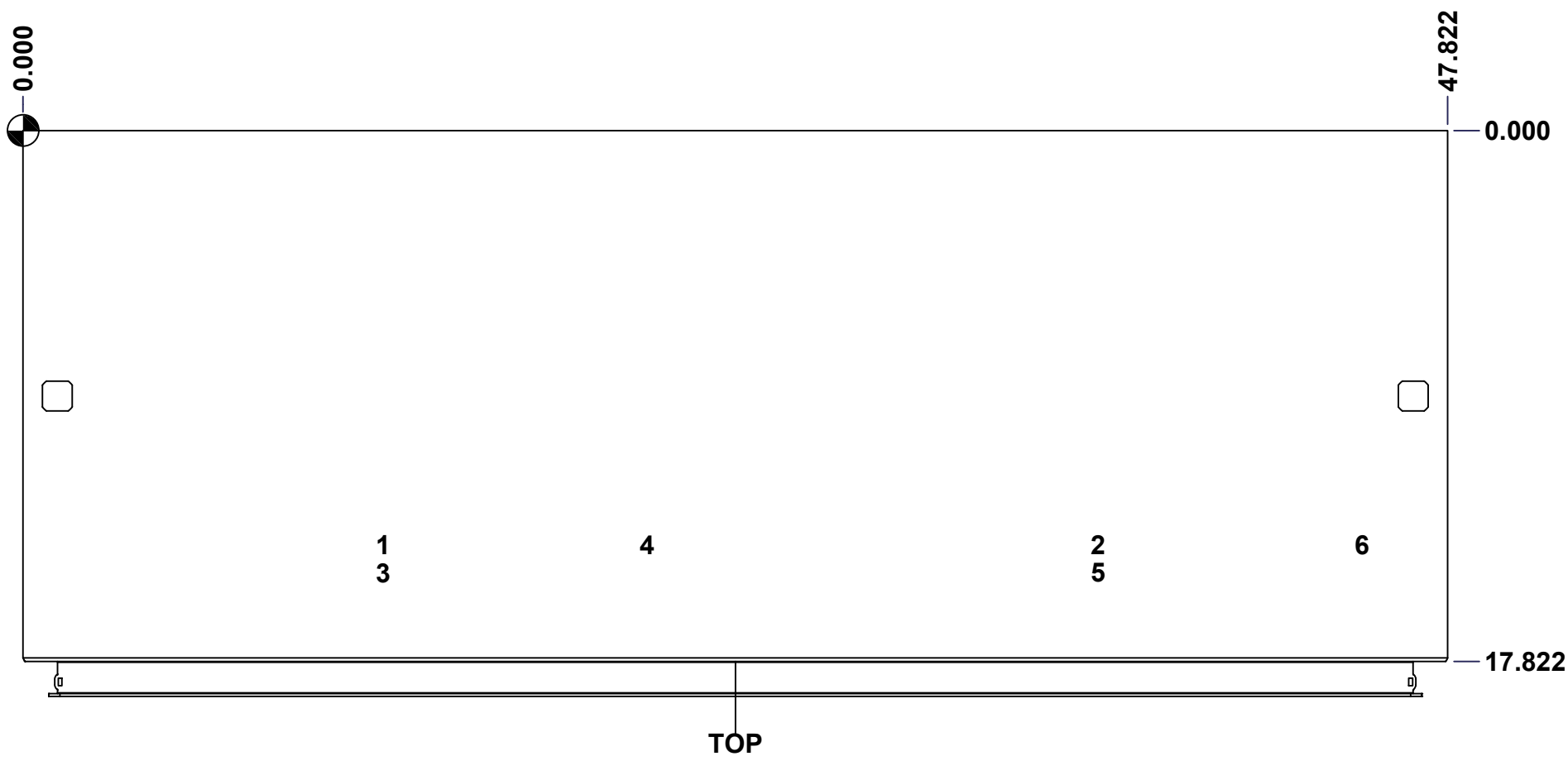

	Description 9500DD 60" x 48" x 18" Body	Status (NULL)
	Part Number Numéro Pièce <b>9500DD604818B</b>	Rev. 4 <b>0</b>

This drawing is confidential and must not be reproduced or used without the consent of EXM

Ce dessin est confidentiel et ne doit pas être reproduit ou utilisé sans le consentement de EXM

**STANDARD FEATURES ARE NOT LISTED IN THIS HOLE TABLE**

**HOLE TABLE - RIGHT VIEW (CUSTOM FEATURE ONLY)**

CUT-OUT	XDIM	YDIM	DESCRIPTION
1	16.411	11.286	GND STUD M6 x 16mm (Inside)
2	6.036	54.107	STUDS M6 x 10mm (Inside)
3	11.786	54.107	STUDS M6 x 10mm (Inside)
4	6.036	7.857	STUDS M6 x 10mm (Inside)
5	11.786	7.857	STUDS M6 x 10mm (Inside)
6	6.036	30.982	STUDS M6 x 10mm (Inside)
7	11.786	30.982	STUDS M6 x 10mm (Inside)

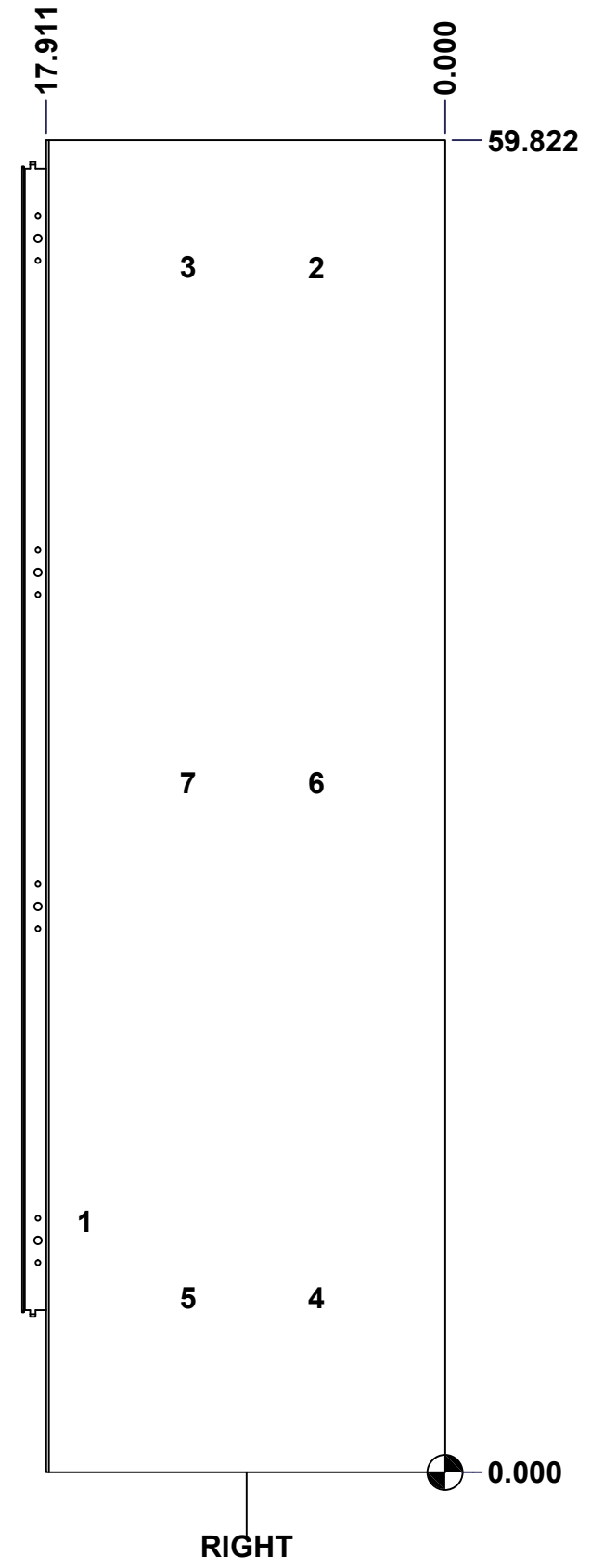

	Description	Status
	9500DD 60" x 48" x 18" Body	(NULL)
	Part Number Numéro Pièce	Rev.
	<b>9500DD604818B</b>	<b>0</b> / 5
		15

This drawing is confidential and must not be reproduced or used without the consent of EXM

Ce dessin est confidentiel et ne doit pas être reproduit ou utilisé sans le consentement de EXM

**STANDARD FEATURES ARE NOT LISTED IN THIS HOLE TABLE**

**HOLE TABLE - BOTTOM VIEW (CUSTOM FEATURE ONLY)**

CUT-OUT	XDIM	YDIM	DESCRIPTION
1	7.286	3.411	GP STUD M6 x 16mm (Inside)
2	16.536	3.411	GP STUD M6 x 16mm (Inside)
3	31.286	3.411	GP STUD M6 x 16mm (Inside)
4	40.536	3.411	GP STUD M6 x 16mm (Inside)

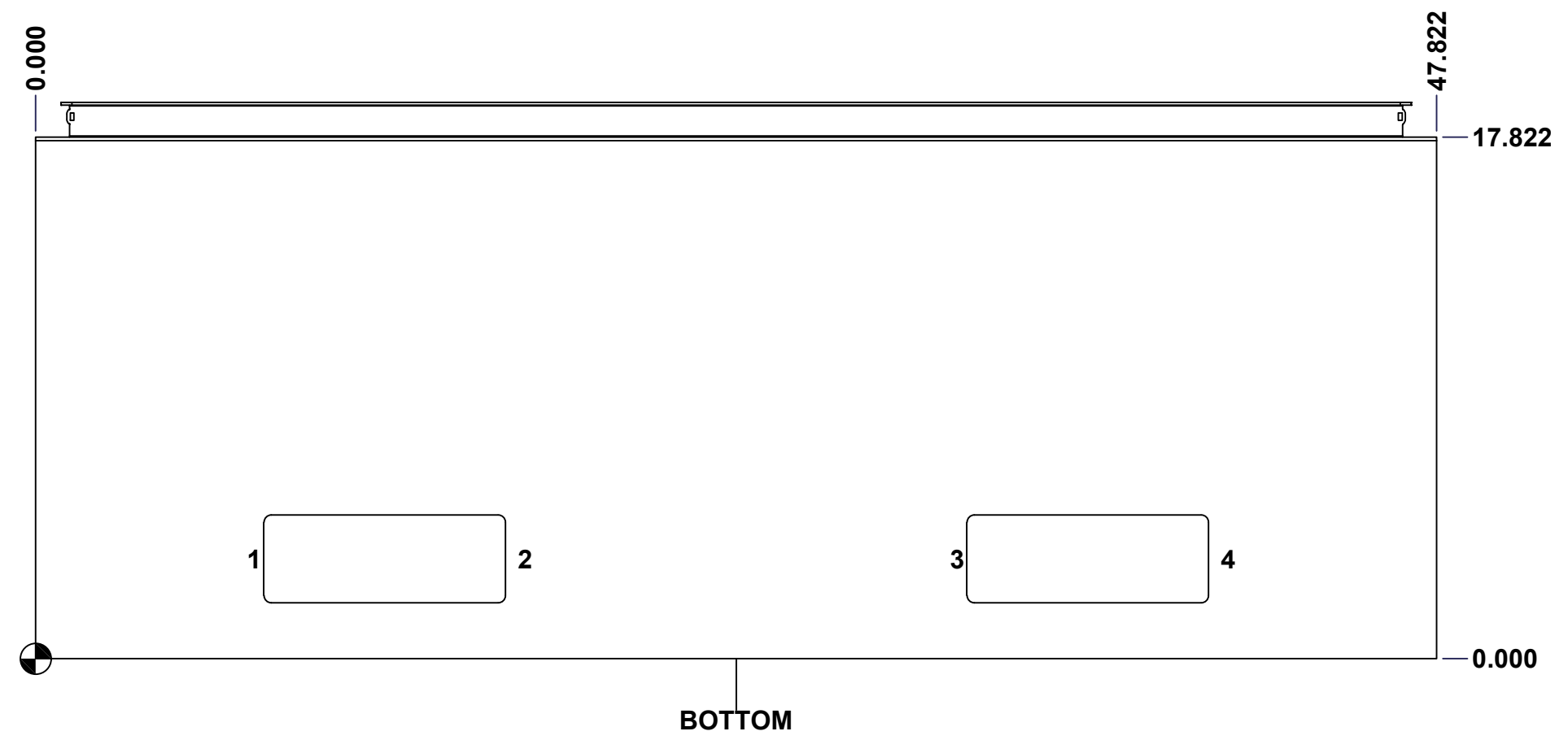

	Description	Status
	9500DD 60" x 48" x 18" Body	(NULL)
	Part Number Numéro Pièce	Rev.
	<b>9500DD604818B</b>	<b>0</b> / 6
		15

This drawing is confidential and must not be reproduced or used without the consent of EXM

Ce dessin est confidentiel et ne doit pas être reproduit ou utilisé sans le consentement de EXM

**STANDARD FEATURES ARE NOT LISTED IN THIS HOLE TABLE**

**HOLE TABLE - LEFT VIEW (CUSTOM FEATURE ONLY)**

CUT-OUT	XDIM	YDIM	DESCRIPTION
1	16.411	11.286	GND STUD M6 x 16mm (Inside)
2	6.036	54.107	STUDS M6 x 10mm (Inside)
3	11.786	54.107	STUDS M6 x 10mm (Inside)
4	6.036	7.857	STUDS M6 x 10mm (Inside)
5	11.786	7.857	STUDS M6 x 10mm (Inside)
6	6.036	30.982	STUDS M6 x 10mm (Inside)
7	11.786	30.982	STUDS M6 x 10mm (Inside)

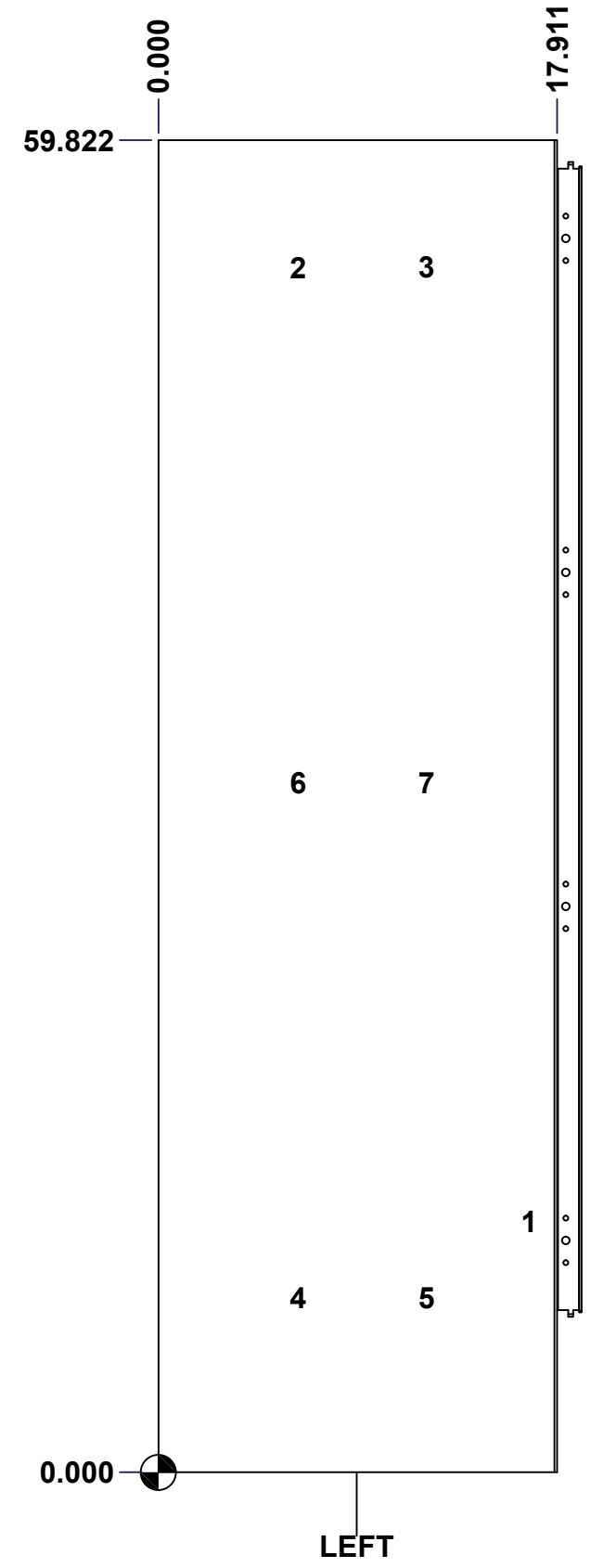

	Description	Status
	9500DD 60" x 48" x 18" Body	(NULL)
Part Number Numéro Pièce	<b>9500DD604818B</b>	Rev. 7
		<b>0</b> / 15

This drawing is confidential and must not be reproduced or used without the consent of EXM

Ce dessin est confidentiel et ne doit pas être reproduit ou utilisé sans le consentement de EXM

No.	Revisions	Date	By/Par

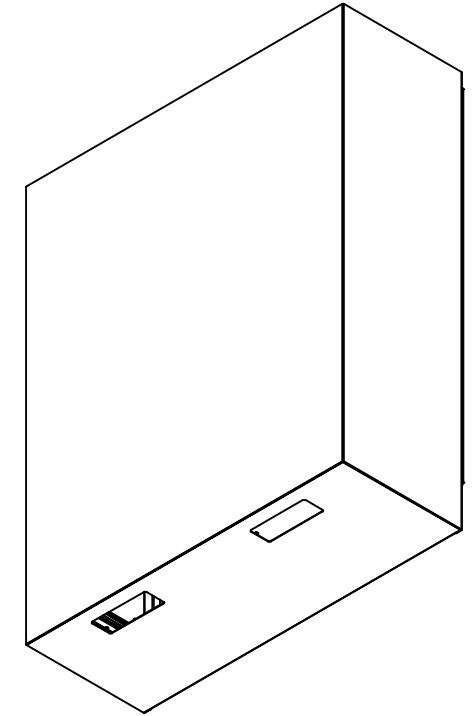

Isometric View

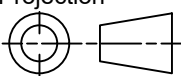

16	STK-Q-16030	0	Stud M6 x 10mm Steel
2	STK-Q-74900	0	Eyebolt Lifting Angle (8.750")
1	STK-P-02400S	0	Powder Paint (Asa-61 Grey / Smooth)
6	STK-Q-52250-18	2	Sasco Strut S5 (17.500" Long)
1	9500DD604818BT-P	0	9500DD 48" x 18" Bottom Part
1	9500DD604818T-P	0	9500DD 48" x 18" Top Part
1	9500DD604818RS-P	0	9500DD 60" x 48" Right Part
1	9500DD604818LS-P	0	9500DD 60" x 48" Left Part
1	9500DD604818B-P	0	9500DD 60" x 48" Back Part
2	CR400MS_17.5	0	Commercial Roll Mild Steel (17.5in long)
6	STK-Q-16080	0	Ground Stud M6 x 16mm Steel
Qty	Part Number	Rev	Description
Parts List			

 Tél: (450) 979-4373 Fax: (450) 979-4626 <a href="http://www.exmweb.com">www.exmweb.com</a>	Flatness Aplatissement	Max 3.0mm
	Projection	
Customer Client	Date	
Drawn By Dessiné Par	BoxCad: BoxCad	Date 20-Dec-13
Material Matière	12 Ga Cold Rolled A1008 CS Type B (2.5mm)	
Color Couleur	Asa-61 Grey	Finish Fini Smooth
Description	Detail Rev.	
9500DD 60" x 48" x 18" Body		
Part Number Numéro Pièce	Rev.	8
<b>9500DD604818B</b>	<b>0</b>	15

This drawing is confidential and must not be reproduced or used without the consent of EXM

Ce dessin est confidentiel et ne doit pas être reproduit ou utilisé sans le consentement de EXM

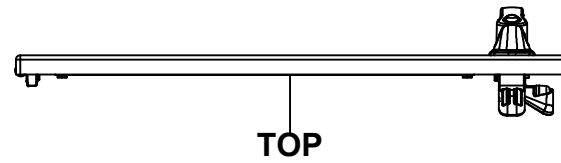

TOP

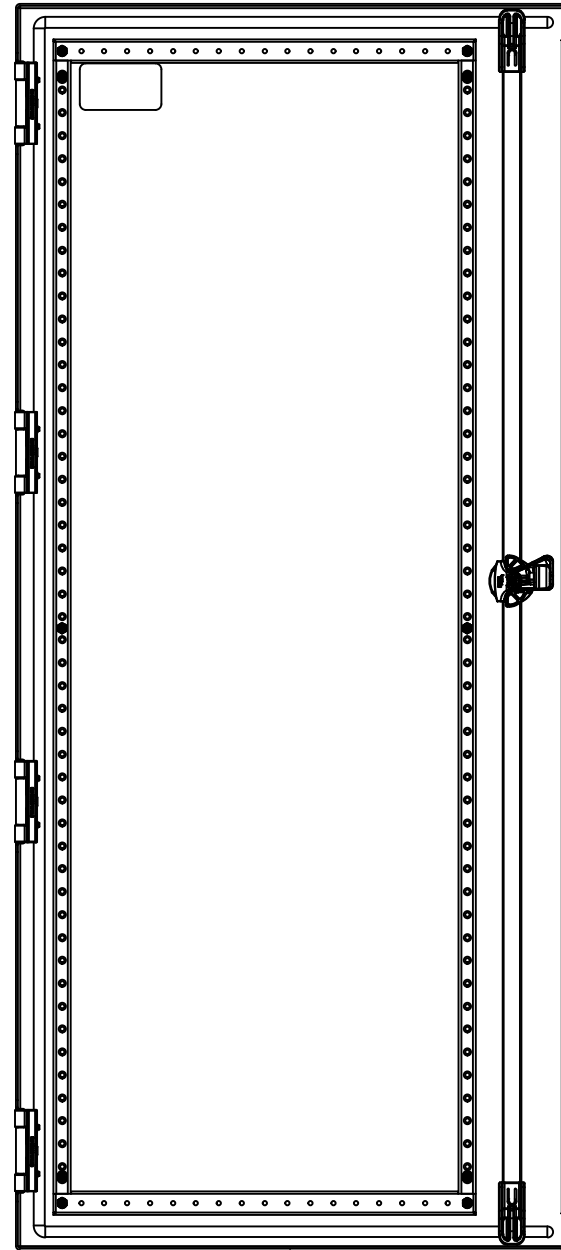

BACK



BOTTOM

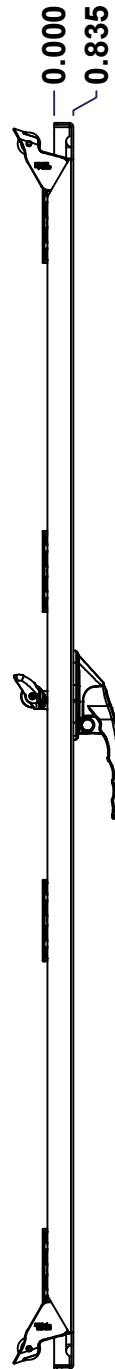

LEFT

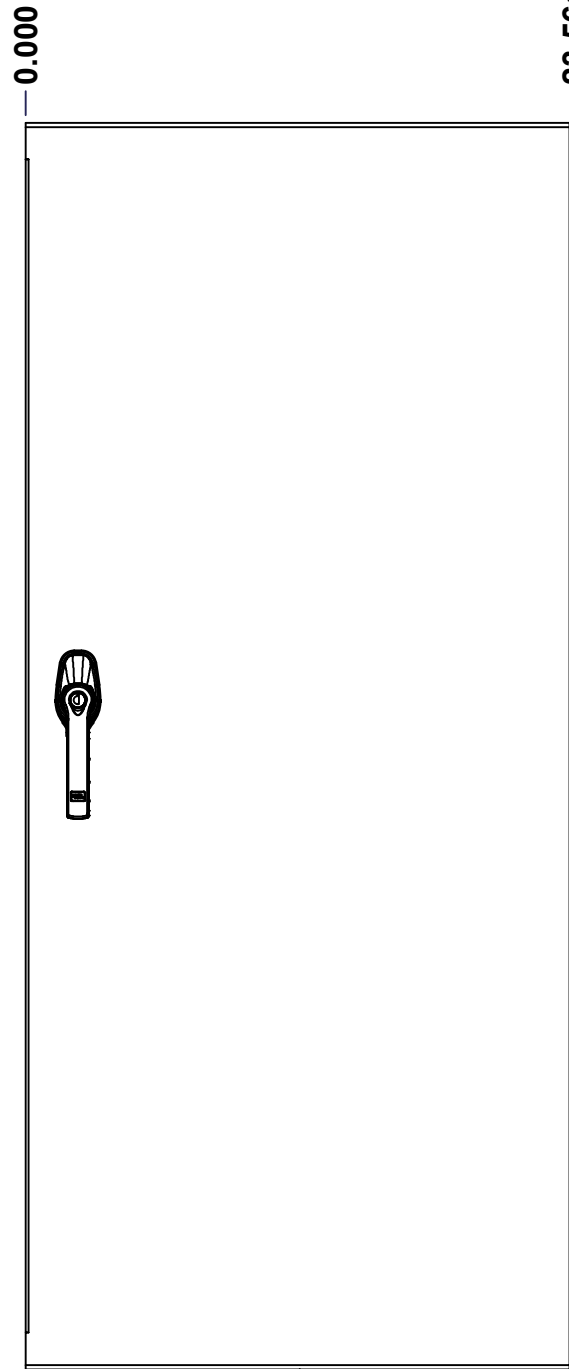

FRONT

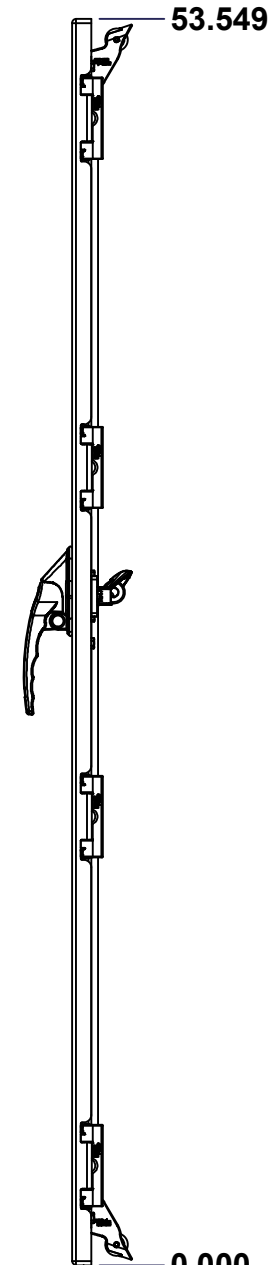

RIGHT

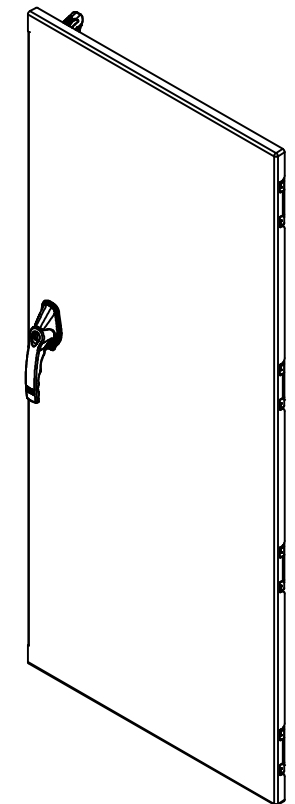

Isometric View

No.	Revisions	Date	By/Par

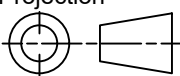

 Tél: (450) 979-4373 Fax: (450) 979-4626 <a href="http://www.exmweb.com">www.exmweb.com</a>		Flatness Aplatissement Max 3.0mm Projection 
Customer Client	Date	
Drawn By Dessiné Par	BoxCad: BoxCad	Date 20-Dec-13
Material Matière	12 Ga Cold Rolled A1008 CS Type B (2.5mm)	
Color Couleur	Asa-61 Grey	Finish Fini Smooth
Description	9500DD 60" x 48" Lock Door	
Part Number Numéro Pièce	Rev. 0	9 / 15

SEE BILL OF MATERIAL ON LAST PAGE

**9500DD604818LD**

This drawing is confidential and must not be reproduced or used without the consent of EXM

Ce dessin est confidentiel et ne doit pas être reproduit ou utilisé sans le consentement de EXM

STANDARD FEATURES ARE NOT LISTED IN THIS HOLE TABLE			
HOLE TABLE - FRONT VIEW (CUSTOM FEATURE ONLY)			
CUT-OUT	XDIM	YDIM	DESCRIPTION
1	1.983	2.028	STUD M6 x 18mm (Inside)
2	1.983	26.722	STUD M6 x 18mm (Inside)
3	1.983	51.521	STUD M6 x 18mm (Inside)
4	1.983	3.139	STUD M6 x 18mm (Inside)
5	1.983	50.409	STUD M6 x 18mm (Inside)
6	19.390	2.028	STUD M6 x 18mm (Inside)
7	19.390	26.722	STUD M6 x 18mm (Inside)
8	19.390	51.521	STUD M6 x 18mm (Inside)
9	19.390	3.139	STUD M6 x 18mm (Inside)
10	19.390	50.409	STUD M6 x 18mm (Inside)
11	21.311	6.118	LARGE CBAR GUIDE (Inside)
12	21.311	47.430	LARGE CBAR GUIDE (Inside)
-----	-----	-----	-----
13	21.311	28.743	HANDLE 885 ESL2A-APHK @ 0.0°

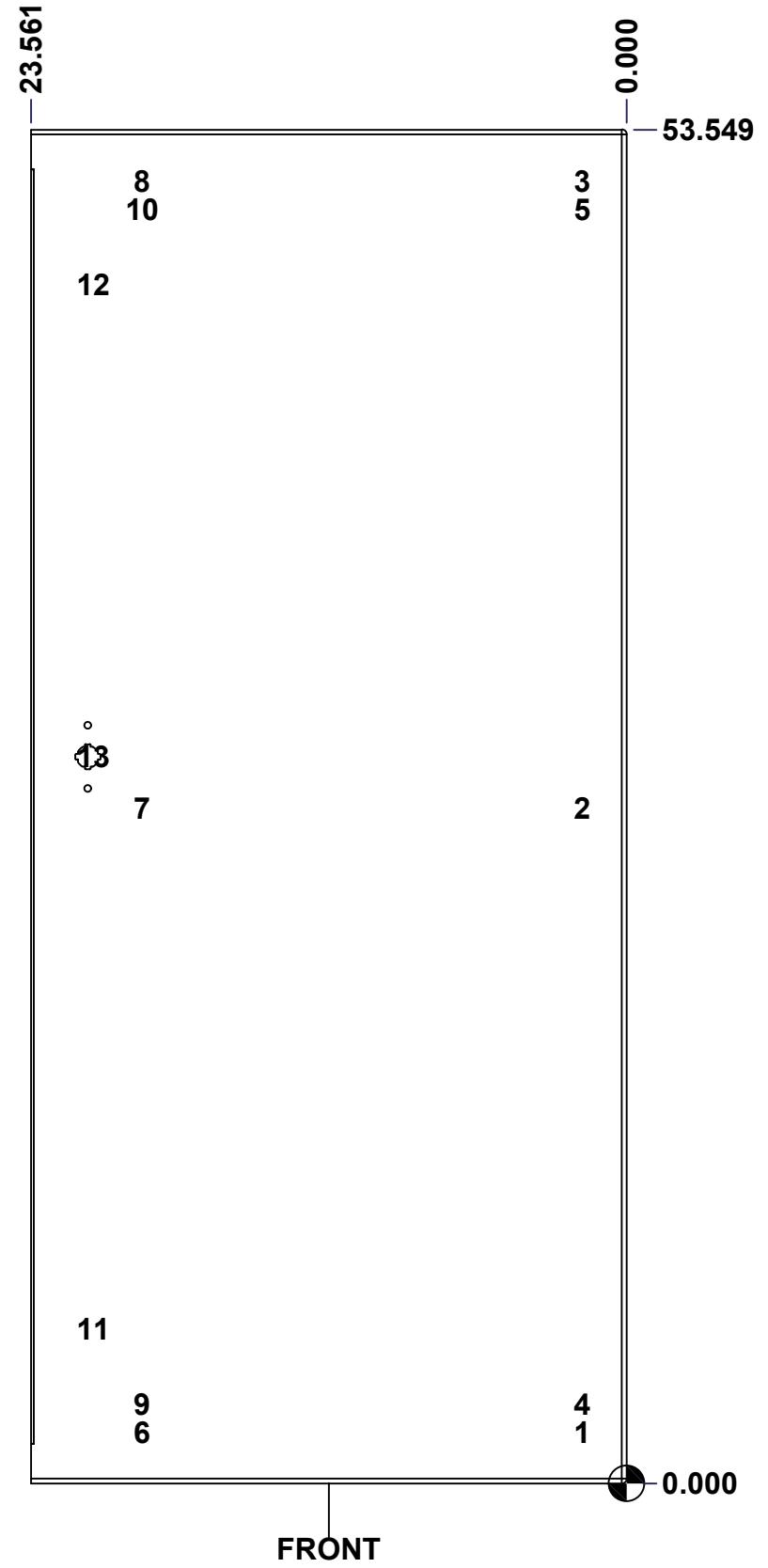

	Description	Status
	9500DD 60" x 48" Lock Door	(NULL)
	Part Number Numéro Pièce	Rev.
	<b>9500DD604818LD</b>	<b>0</b>
		10
		15

This drawing is confidential and must not be reproduced or used without the consent of EXM

Ce dessin est confidentiel et ne doit pas être reproduit ou utilisé sans le consentement de EXM

No.	Revisions	Date	By/Par

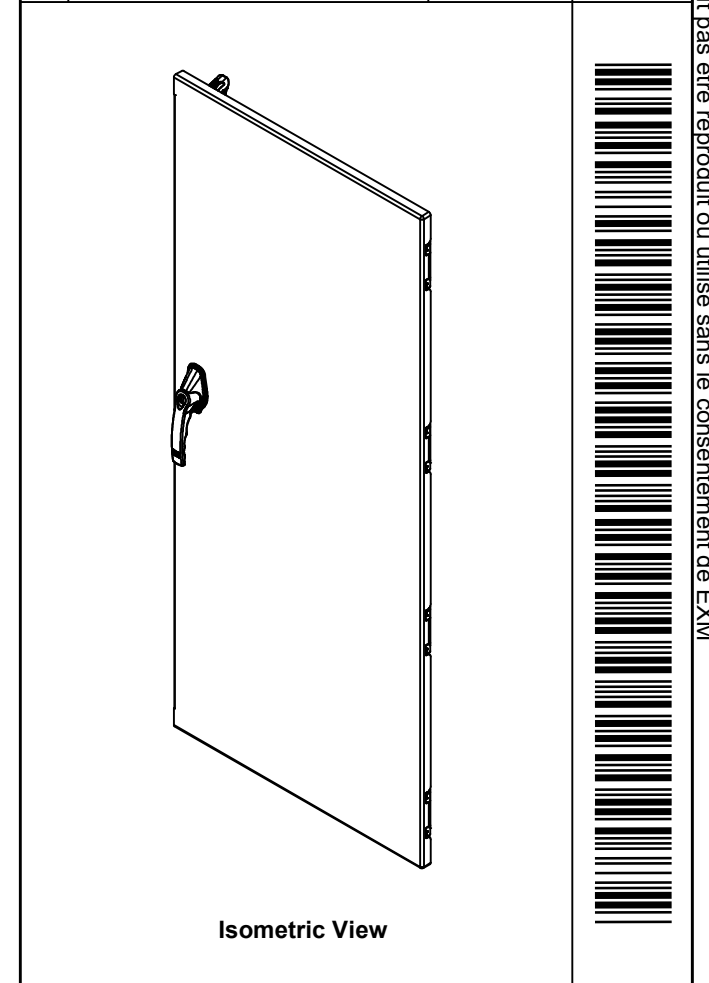

1	STK-Q-47561	0	9500 Lower Closing Bar 60" (cam)
1	STK-Q-47551	0	9500 Upper Closing Bar 60" (cam)
1	STK-A-50537	3	9500 Handle Cam Assembly (Left Side, Grip 36mm)
1	STK-Q-90051	3	5412 ES - Handle Cam Spacer
1	885ESL2A-APHK	7	885 ESL2A-APHK - Zinc Die Cast L-Handle Padlockable Assy
1	STK-P-02400S	0	Powder Paint (Asa-61 Grey / Smooth)
1	STK-S-00100	0	3.5" x 2" Silver Milar Flexcon Sticker
1	STK-K-10800	3	9500 - Door Stiffener Assembly
2	STK-Q-16410	0	Guide Stud - Largel (No Paint Cap Required)
10	STK-Q-16055	1	M6 x 18mm Stud (No Paint Cap Required)
1	9500DD604818LDG	0	9500DD 60" x 48" Lock Door Gasket
1	9500DD604818LD-P	0	9500DD 60" x 48" Lock Door Part
2	STK-A-90025	0	9500 - Cabinet Closing Bar End (Large)
4	STK-K-09860	7	Cabinet Hinge with Captive Pins
2	STK-Q-07220	1	M6 Nylon Insert Lock Nut

QTY	Part Number	Rev	Description
Parts List			

<p>Tél: (450) 979-4373 Fax: (450) 979-4626 <a href="http://www.exmweb.com">www.exmweb.com</a></p>	Flatness Aplatissement	Max 3.0mm
	Projection	
Customer Client	Date	
Drawn By Dessiné Par	BoxCad: BoxCad	Date 20-Dec-13
Material Matière	12 Ga Cold Rolled A1008 CS Type B (2.5mm)	
Color Couleur	Asa-61 Grey	Finish Fini Smooth
Description	9500DD 60" x 48" Lock Door	
Part Number Numéro Pièce	Rev. 0	11 / 15
<b>9500DD604818LD</b>		

This drawing is confidential and must not be reproduced or used without the consent of EXM

Ce dessin est confidentiel et ne doit pas être reproduit ou utilisé sans le consentement de EXM

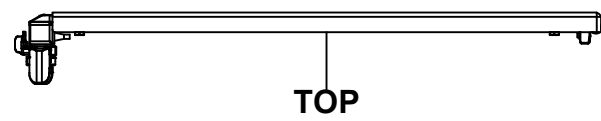

TOP

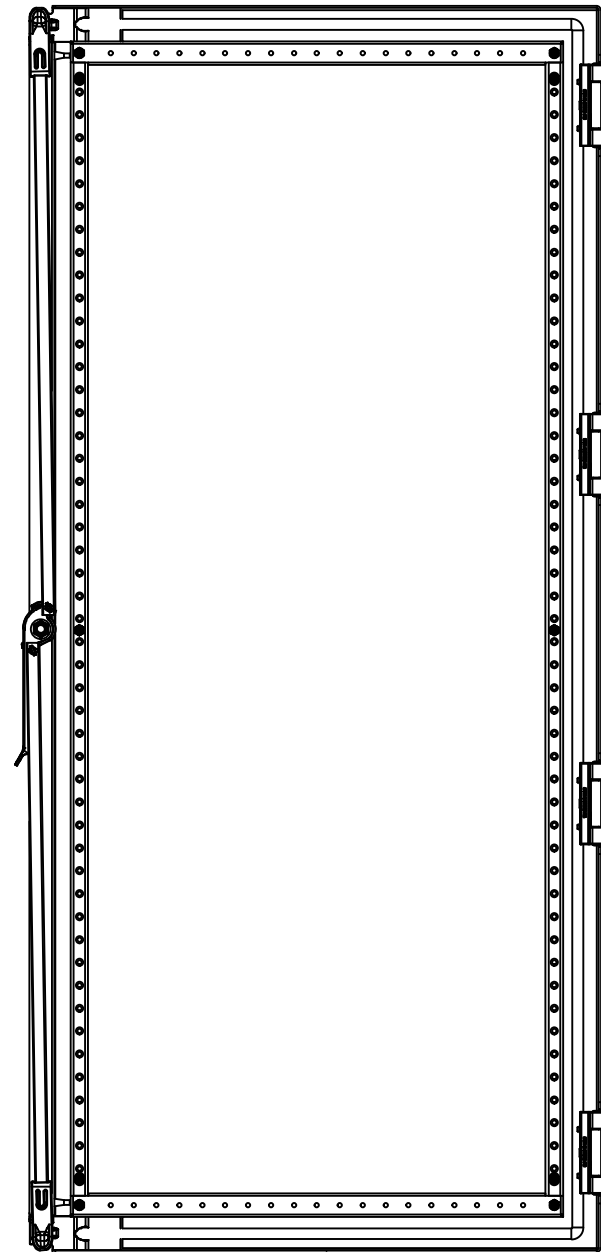

BACK

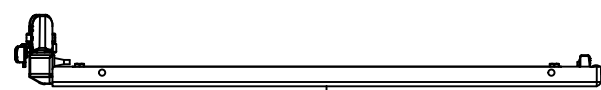

BOTTOM

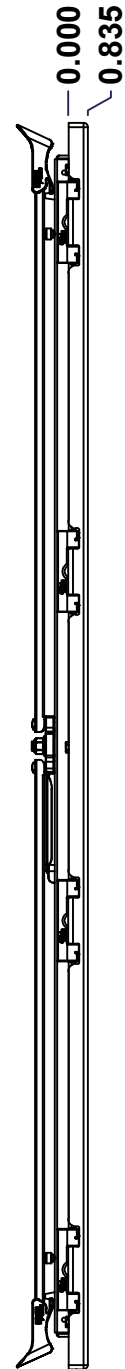

LEFT

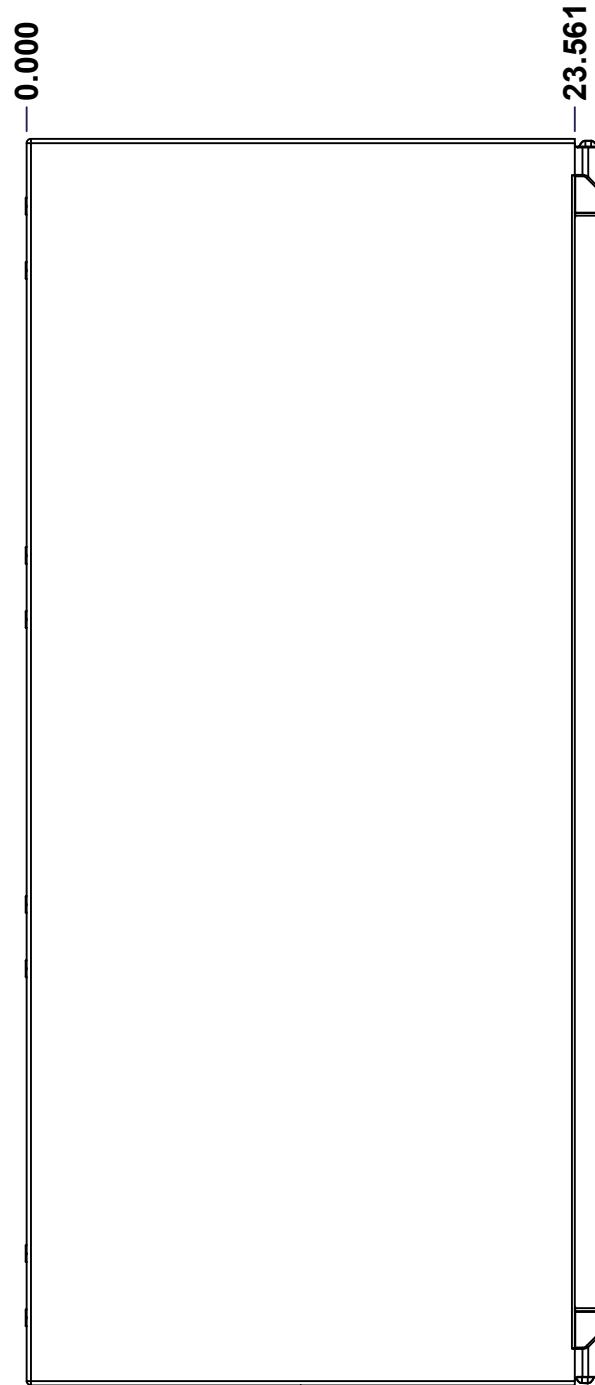

FRONT

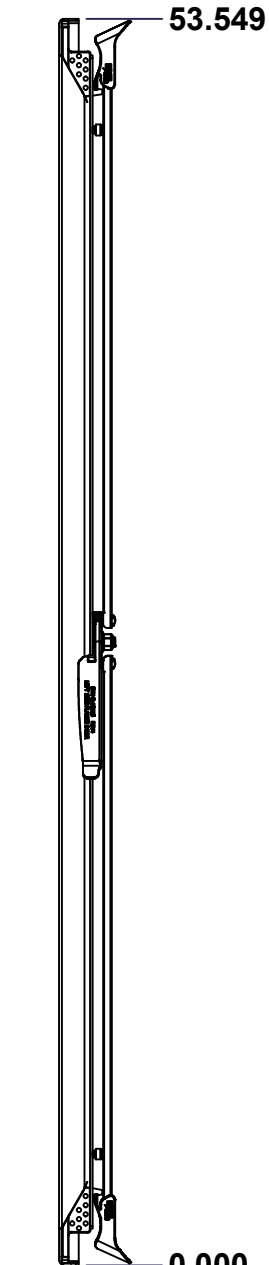

RIGHT

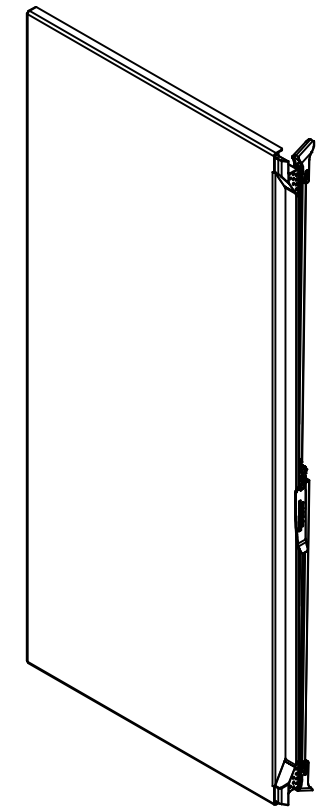

Isometric View

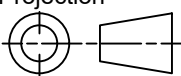

No.	Revisions	Date	By/Par

 Tél: (450) 979-4373 Fax: (450) 979-4626 <a href="http://www.exmweb.com">www.exmweb.com</a>		Flatness Aplatissement Max 3.0mm Projection 
Customer Client	Date	
Drawn By Dessiné Par	BoxCad: BoxCad	Date 20-Dec-13
Material Matière	12 Ga Cold Rolled A1008 CS Type B (2.5mm)	
Color Couleur	Asa-61 Grey	Finish Fini Smooth
Description	Detail Rev.	
9500DD 60" x 48" Flange Door		
Part Number Numéro Pièce	Rev. 0	12 / 15
9500DD604818FD		

SEE BILL OF MATERIAL ON LAST PAGE

This drawing is confidential and must not be reproduced or used without the consent of EXM

Ce dessin est confidentiel et ne doit pas être reproduit ou utilisé sans le consentement de EXM

**STANDARD FEATURES ARE NOT LISTED IN THIS HOLE TABLE**

**HOLE TABLE - FRONT VIEW (CUSTOM FEATURE ONLY)**

CUT-OUT	XDIM	YDIM	DESCRIPTION
1	2.000	2.028	STUD M6 x 18mm (Inside)
2	2.000	26.722	STUD M6 x 18mm (Inside)
3	2.000	51.521	STUD M6 x 18mm (Inside)
4	2.000	3.139	STUD M6 x 18mm (Inside)
5	2.000	50.409	STUD M6 x 18mm (Inside)
6	22.407	2.028	STUD M6 x 18mm (Inside)
7	22.407	26.722	STUD M6 x 18mm (Inside)
8	22.407	51.521	STUD M6 x 18mm (Inside)
9	22.407	3.139	STUD M6 x 18mm (Inside)
10	22.407	50.409	STUD M6 x 18mm (Inside)
11	24.061	4.774	SMALL CBAR GUIDE (Inside)
12	24.061	48.774	SMALL CBAR GUIDE (Inside)
13	24.061	26.774	STUD M10 x 25mm (Inside)

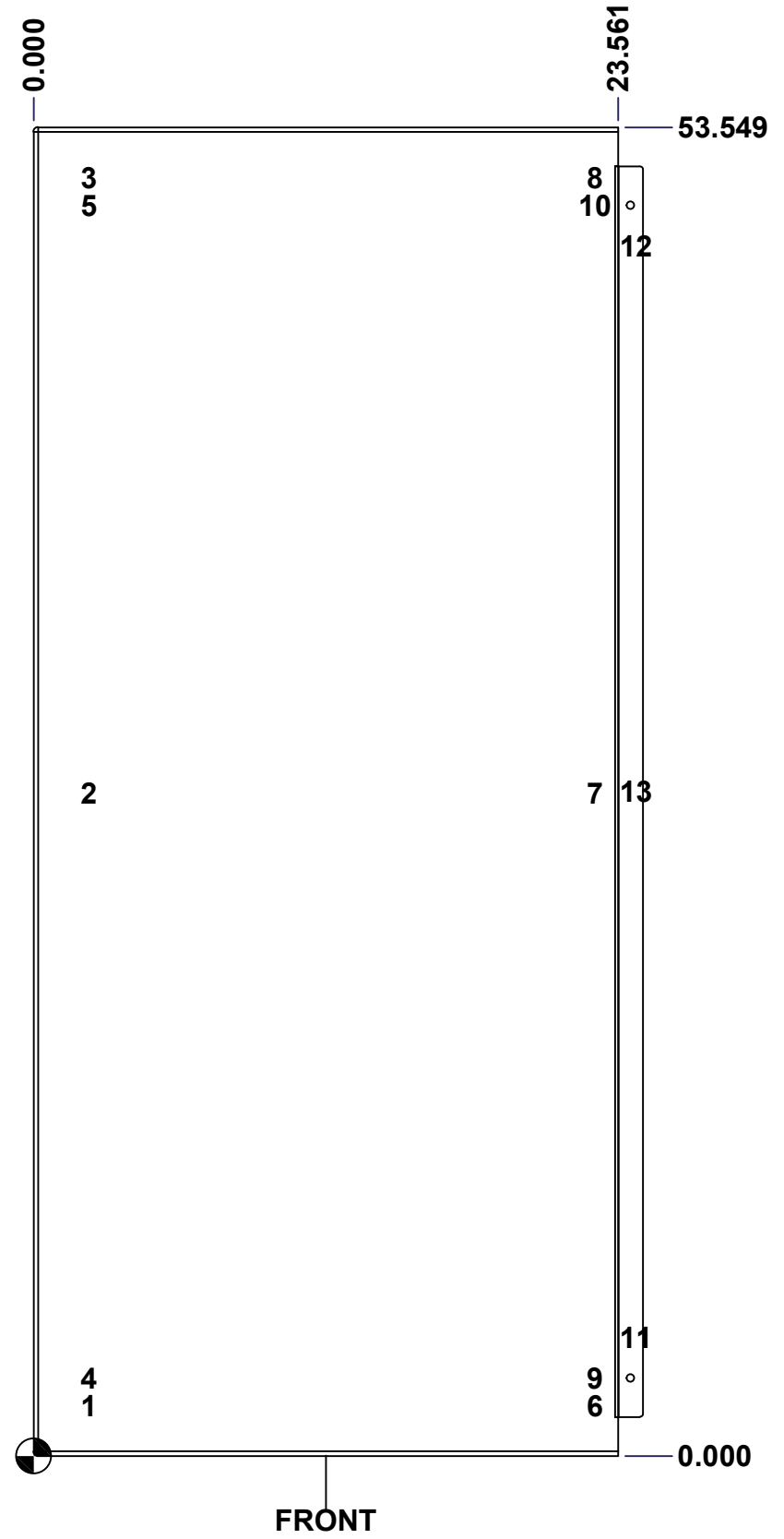

FRONT

	Description	Status
	9500DD 60" x 48" Flange Door	(NULL)
	Part Number Numéro Pièce	Rev.
	9500DD604818FD	0
		13
		15

This drawing is confidential and must not be reproduced or used without the consent of EXM

Ce dessin est confidentiel et ne doit pas être reproduit ou utilisé sans le consentement de EXM

No.	Revisions	Date	By/Par

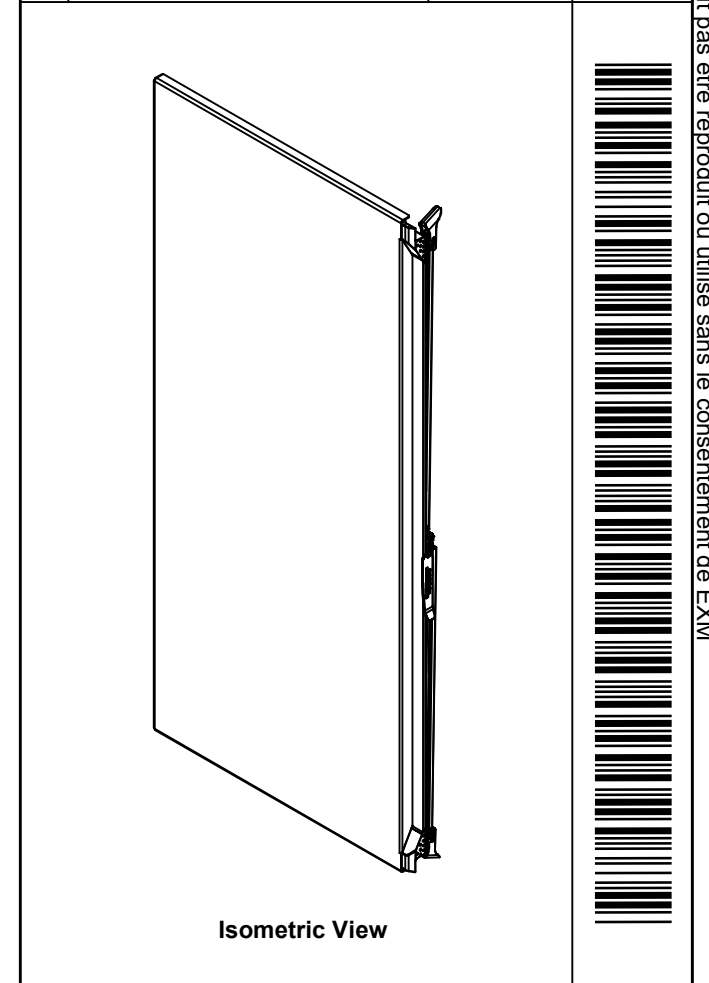

1	STK-P-02400S	0	Powder Paint (Asa-61 Grey / Smooth)
1	STK-G-03400	1	5500 DD Lower Flange Door Gasket
1	STK-G-03300	2	5500 DD Upper Flange Door Gasket
2	STK-Q-90045	0	Cabinet - Closing Bar End
2	STK-Q-45660-60	2	9500 DD - Flange Door Closing Bar
1	STK-Q-07440	0	M10 Nylon Insert Flanged Lock Nut
1	STK-Q-50568	1	Flange Door Handle Spacer
1	STK-A-50556	4	Left Side Flange Door Handle Assembly
1	STK-K-20800	4	9500 - Flange Door Stiffener Assembly
1	STK-Q-15005	0	Stud M10 x 25mm
2	STK-Q-16405	7	Guide Stud - Small (No Paint Cap Required)
10	STK-Q-16055	1	M6 x 18mm Stud (No Paint Cap Required)
1	STK-G-00701	0	1" x 1/4" Self-Adhesive Neoprene Gasket
1	9500DD604818FDG	0	9500DD 60" x 48" Flange Door Gasket
1	9500DD604818FD-P	0	9500DD 60" x 48" Flange Door Part
4	STK-K-09860	7	Cabinet Hinge with Captive Pins
QTY	Part Number	Rev	Description
Parts List			

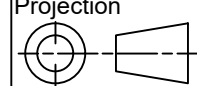
 Tél: (450) 979-4373 Fax: (450) 979-4626 <a href="http://www.exmweb.com">www.exmweb.com</a>	Flatness Aplatissement
	Max 3.0mm
Projection	
Customer Client	Date
Drawn By Dessiné Par	Date 20-Dec-13
Material Matière	12 Ga Cold Rolled A1008 CS Type B (2.5mm)
Color Couleur	Asa-61 Grey
Finish Fini	Smooth
Description	Detail Rev.
9500DD 60" x 48" Flange Door	
Part Number Numéro Pièce	Rev. 14
<b>9500DD604818FD</b>	<b>0</b> 15

All knockouts are actual size / Les disques défonçables sont grandeur réel  
 All dimensions are before paint / Toutes les dimensions sont avant peinture

This drawing is confidential and must not be reproduced or used without the consent of EXM

Ce dessin est confidentiel et ne doit pas être reproduit ou utilisé sans le consentement de EXM

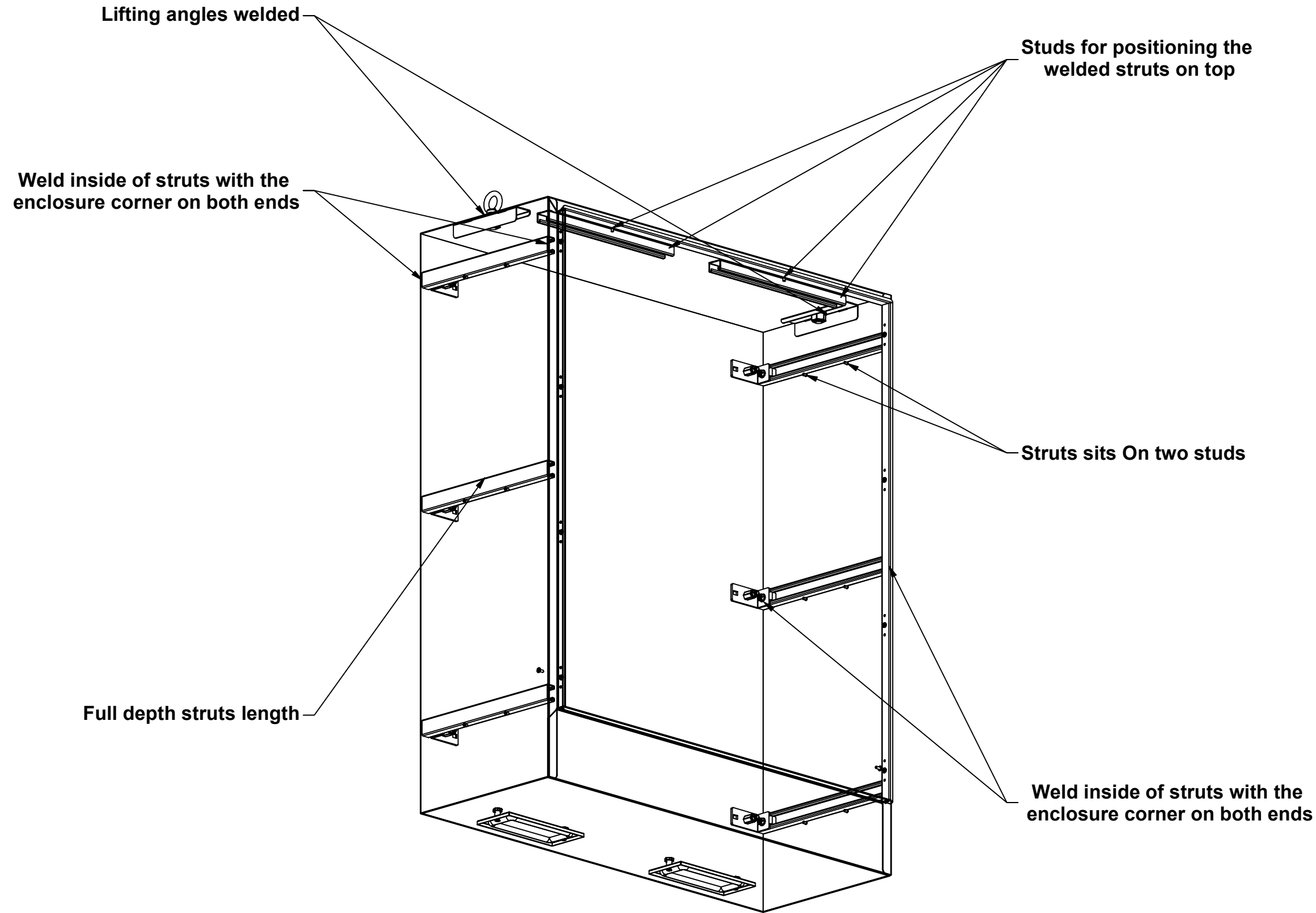

No.	Revisions	Date	By/Par

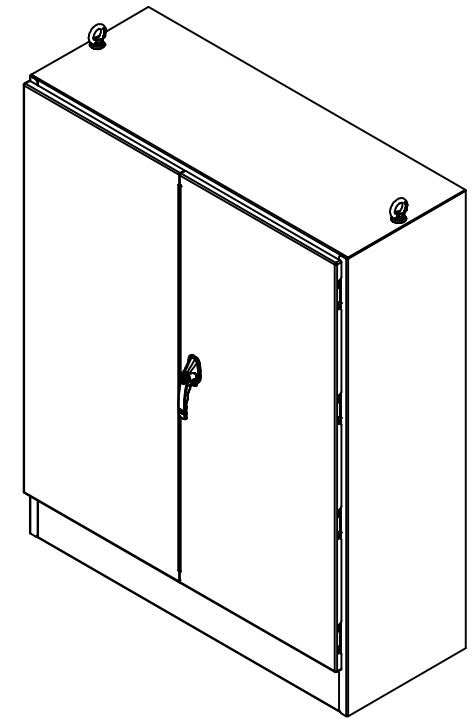

Isometric View



	Tél: (450) 979-4373 Fax: (450) 979-4626 <a href="http://www.exmweb.com">www.exmweb.com</a>	Flatness Aplatissement Max 3.0mm
	Projection 	Date
Customer Client		Date 11-Aug-05
Drawn By / Dessiné Par	BoxCad	
Material / Matière	12 Ga Cold Rolled A1008 CS Type B (2.5mm)	
Color / Couleur	Asa-61 Grey	Finish / Fini: Smooth
Description	9500DD 60" x 48" x 18" Assembly	Detail Rev.
Part Number / Numéro Pièce	9500DD Welding Details	Rev. 0 / 15