

This drawing is confidential and must not be reproduced or used without the consent of EXM

Ce dessin est confidentiel et ne doit pas être reproduit ou utilisé sans le consentement de EXM

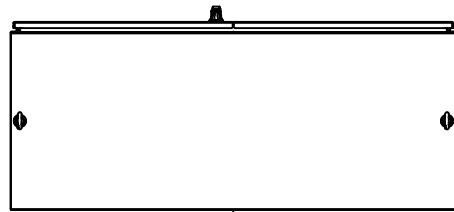

TOP

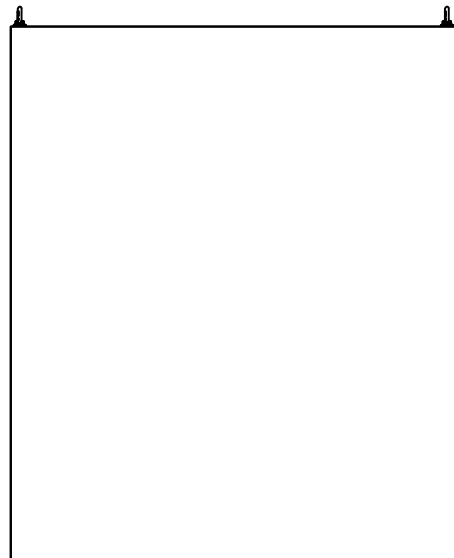

BACK

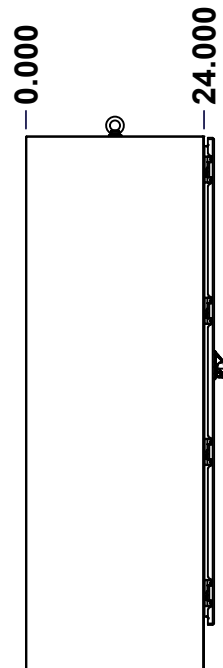

LEFT

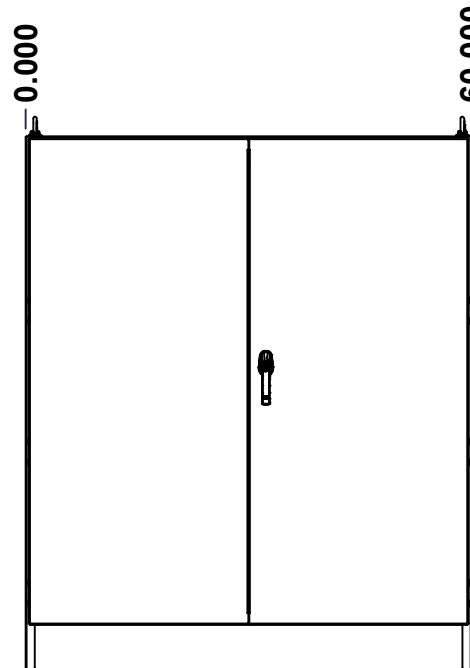

FRONT

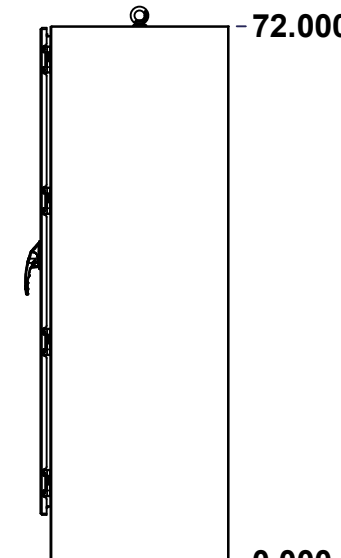

RIGHT

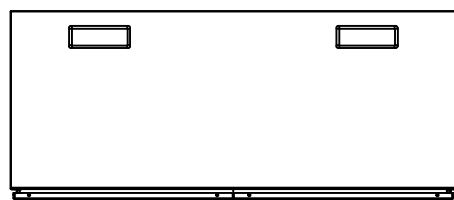

BOTTOM

No.	Revisions	Date	By/Par

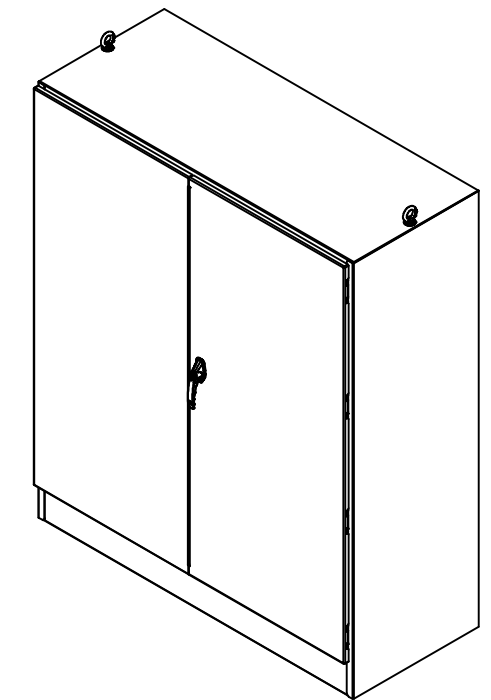

Isometric View

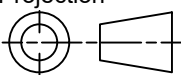

 Tél: (450) 979-4373 Fax: (450) 979-4626 www.exmweb.com	Flatness Aplatissement	Max 3.0mm
	Projection	
Customer Client	Date	
Drawn By Dessiné Par	BoxCad: BoxCad	Date 15-Sep-14
Material Matière	12 Ga Cold Rolled A1008 CS Type B (2.5mm)	
Color Couleur	Asa-61 Grey	Finish Fini Smooth
Description	Detail Rev.	
9500DD 72" x 60" x 24" Assembly		
Part Number Numéro Pièce	Rev. 0	1 / 15
9500DD726024		

SEE BILL OF MATERIAL ON LAST PAGE

This drawing is confidential and must not be reproduced or used without the consent of EXM

Ce dessin est confidentiel et ne doit pas être reproduit ou utilisé sans le consentement de EXM

NOTE	
ITEM	DESCRIPTION
1	NEMA 12, 13 Enclosure (IP55)
2	C/W Standard ground studs on box and cover
3	C/W Standard door stiffener
4	W/O Inner panel
5	C/W Standard inner panel mounting struts
6	C/W Eyebolts sold separately (Installed by EXM)
7	C/W Struts installed (Included)

No.	Revisions	Date	By/Par

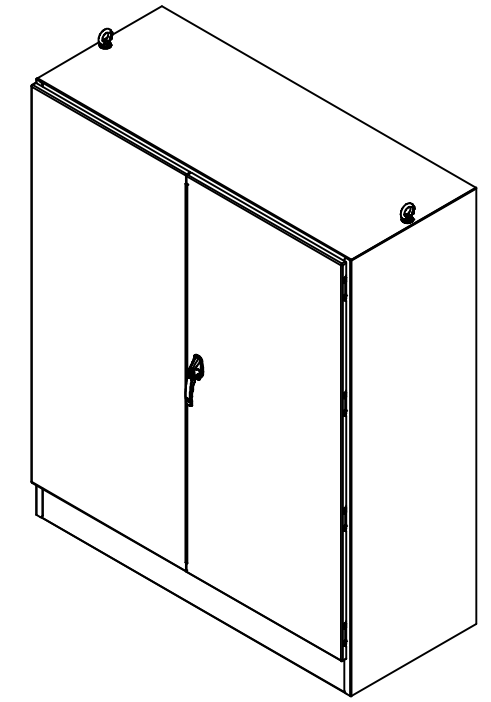

Isometric View

PACKING		
ITEM	QTY	DESCRIPTION
Cardboard sleeve	2	Top and Bottom
Cardboard strip	2	Between back of enclosure and inner panel
Plastic bag	1	To protect cover surface and inside gasket
Cardboard corner	4	To reinforced for the plastic strap tightening
Plastic strap - Black	2	To Squeeze 2 cardboard sleeve together
Packaging label	3	White label with PN
Plastic strap- Green	2	To secure the enclosure to the wood pallet
Wood Pallet	1	2" deeper and 3" larger than enclosure size

1	880EB14	2	Eye Bolt M14 (Pack of 2)
1	889BPS	0	Inner Panel Strut Mounting Kit
1	9500DD726024FD	0	9500DD 72" x 60" Flange Door
1	9500DD726024LD	0	9500DD 72" x 60" Lock Door
1	9500DD726024B	0	9500DD 72" x 60" x 24" Body
2	9500DD726024GP	0	9500DD Gland Plate
8	STK-Q-04050-10	8	M6 x 10mm Hexagon Socket Head Machine Screw with Nyseal
Qty	Part Number	Rev	Description
Parts List			

	Tél: (450) 979-4373 Fax: (450) 979-4626 www.exmweb.com	Flatness Aplatissement Max 3.0mm
	Projection	
Customer Client	Date	
Drawn By Dessiné Par	BoxCad: BoxCad	Date 15-Sep-14
Material Matière	12 Ga Cold Rolled A1008 CS Type B (2.5mm)	
Color Couleur	Asa-61 Grey	Finish Fini Smooth
Description	9500DD 72" x 60" x 24" Assembly	
Part Number Numéro Pièce	9500DD726024	Detail Rev. Rev. 2
		0 15

This drawing is confidential and must not be reproduced or used without the consent of EXM

Ce dessin est confidentiel et ne doit pas être reproduit ou utilisé sans le consentement de EXM

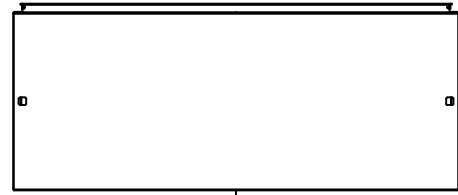

TOP

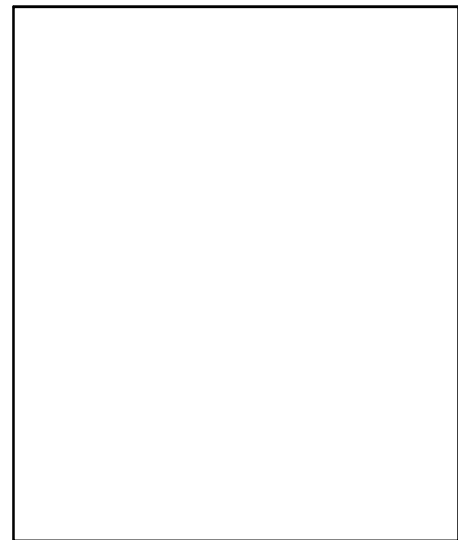

BACK

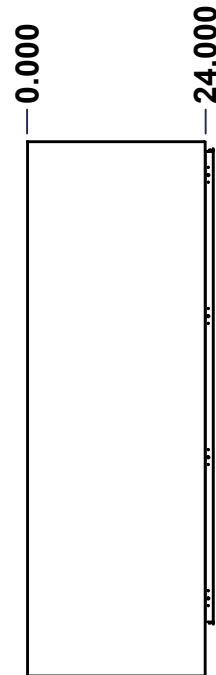

LEFT

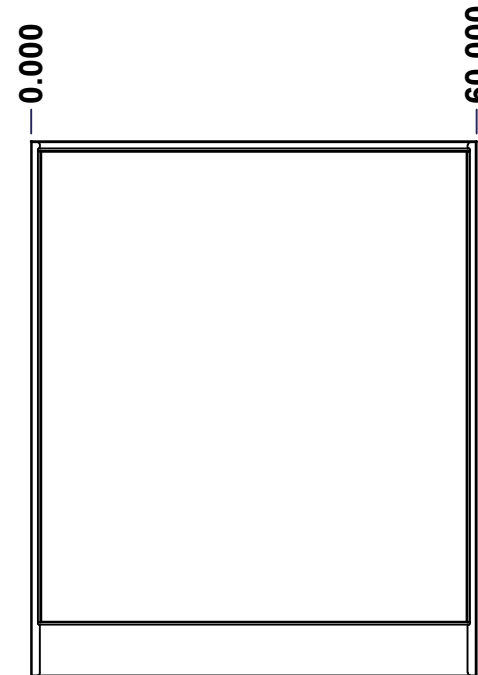

FRONT

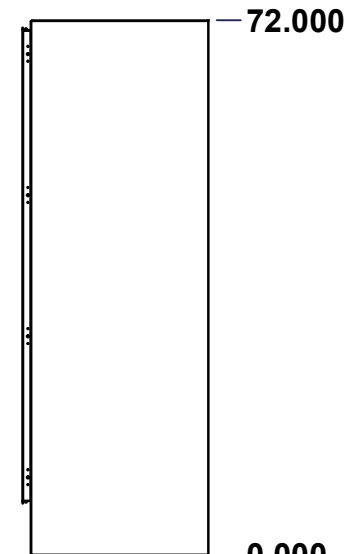

RIGHT

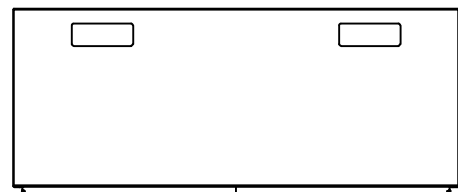

BOTTOM

No.	Revisions	Date	By/Par

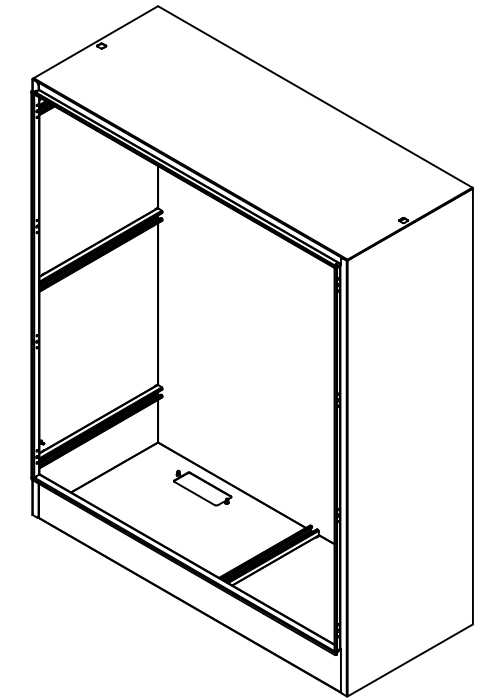

Isometric View



Tél: (450) 979-4373
 Fax: (450) 979-4626
www.exmweb.com

Flatness
Aplatissement

Max 3.0mm

Projection



Customer Client	Date
Drawn By Dessiné Par BoxCad: BoxCad	Date 15-Sep-14

Material Matière 12 Ga Cold Rolled A1008 CS Type B (2.5mm)

Color Couleur	Asa-61 Grey	Finish Fini	Smooth
---------------	-------------	-------------	--------

Description	Detail Rev.
9500DD 72" x 60" x 24" Body	

Part Number Numéro Pièce	Rev.	3
9500DD726024B	0	15

SEE BILL OF MATERIAL ON LAST PAGE

This drawing is confidential and must not be reproduced or used without the consent of EXM

Ce dessin est confidentiel et ne doit pas être reproduit ou utilisé sans le consentement de EXM

STANDARD FEATURES ARE NOT LISTED IN THIS HOLE TABLE

HOLE TABLE - TOP VIEW (CUSTOM FEATURE ONLY)

CUT-OUT	XDIM	YDIM	DESCRIPTION
1	14.911	19.911	Struts CR400 21.500" (Inside)
2	44.911	19.911	Struts CR400 21.500" (Inside)
3	14.911	20.840	STUDS M6 x 10mm (Inside)
4	25.777	19.911	STUDS M6 x 10mm (Inside)
5	44.911	20.840	STUDS M6 x 10mm (Inside)
6	55.777	19.911	STUDS M6 x 10mm (Inside)
7	28.982	7.536	STUDS M6 x 10mm (Inside)
8	28.982	16.286	STUDS M6 x 10mm (Inside)

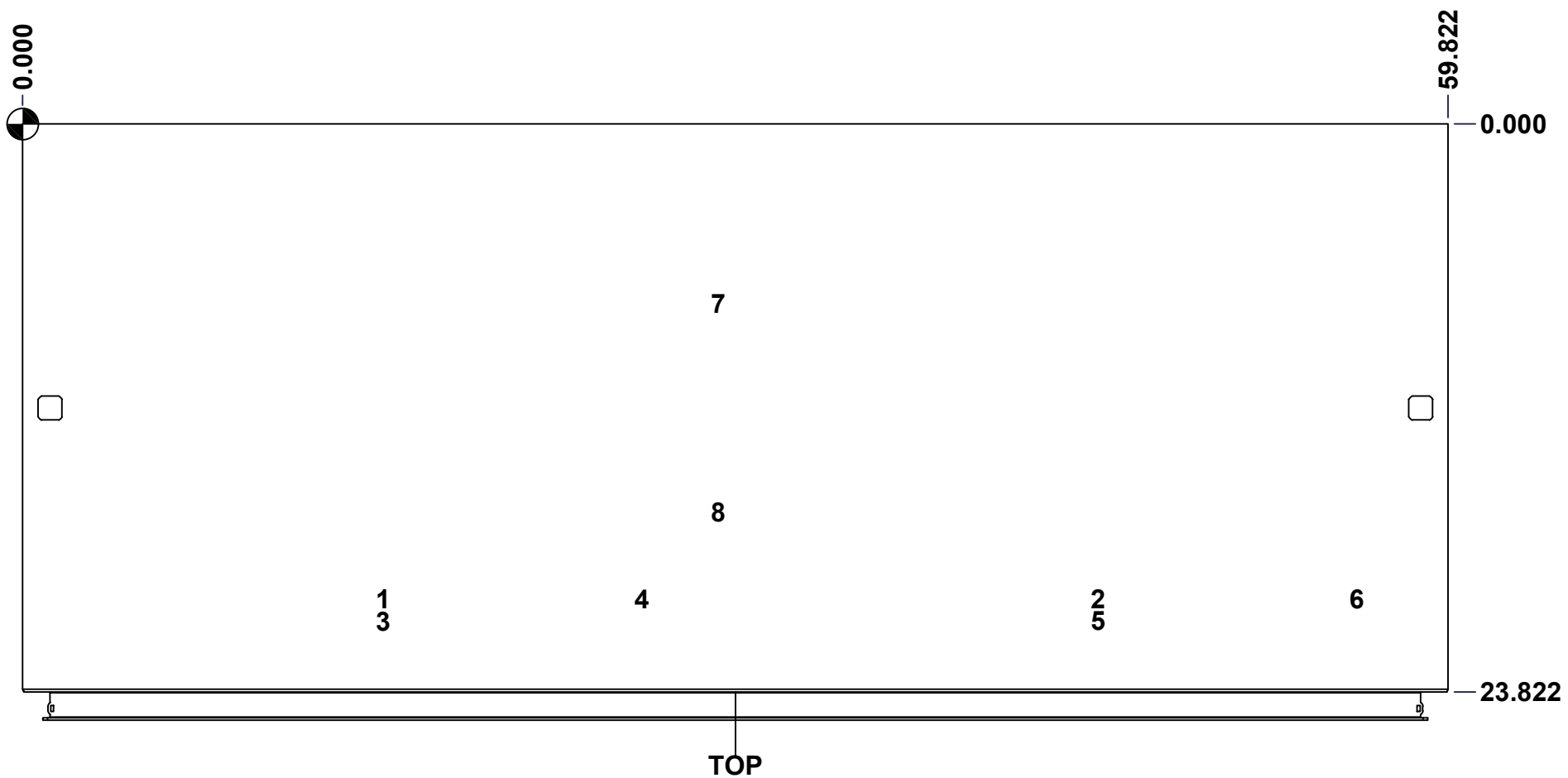

	Description 9500DD 72" x 60" x 24" Body	Status (NULL)
	Part Number Numéro Pièce 9500DD726024B	Rev. 4 0

This drawing is confidential and must not be reproduced or used without the consent of EXM

Ce dessin est confidentiel et ne doit pas être reproduit ou utilisé sans le consentement de EXM

STANDARD FEATURES ARE NOT LISTED IN THIS HOLE TABLE

HOLE TABLE - RIGHT VIEW (CUSTOM FEATURE ONLY)

CUT-OUT	XDIM	YDIM	DESCRIPTION
1	22.411	11.286	GND STUD M6 x 16mm (Inside)
2	7.536	66.107	STUDS M6 x 10mm (Inside)
3	16.286	66.107	STUDS M6 x 10mm (Inside)
4	7.536	7.857	STUDS M6 x 10mm (Inside)
5	16.286	7.857	STUDS M6 x 10mm (Inside)
6	7.536	36.982	STUDS M6 x 10mm (Inside)
7	16.286	36.982	STUDS M6 x 10mm (Inside)

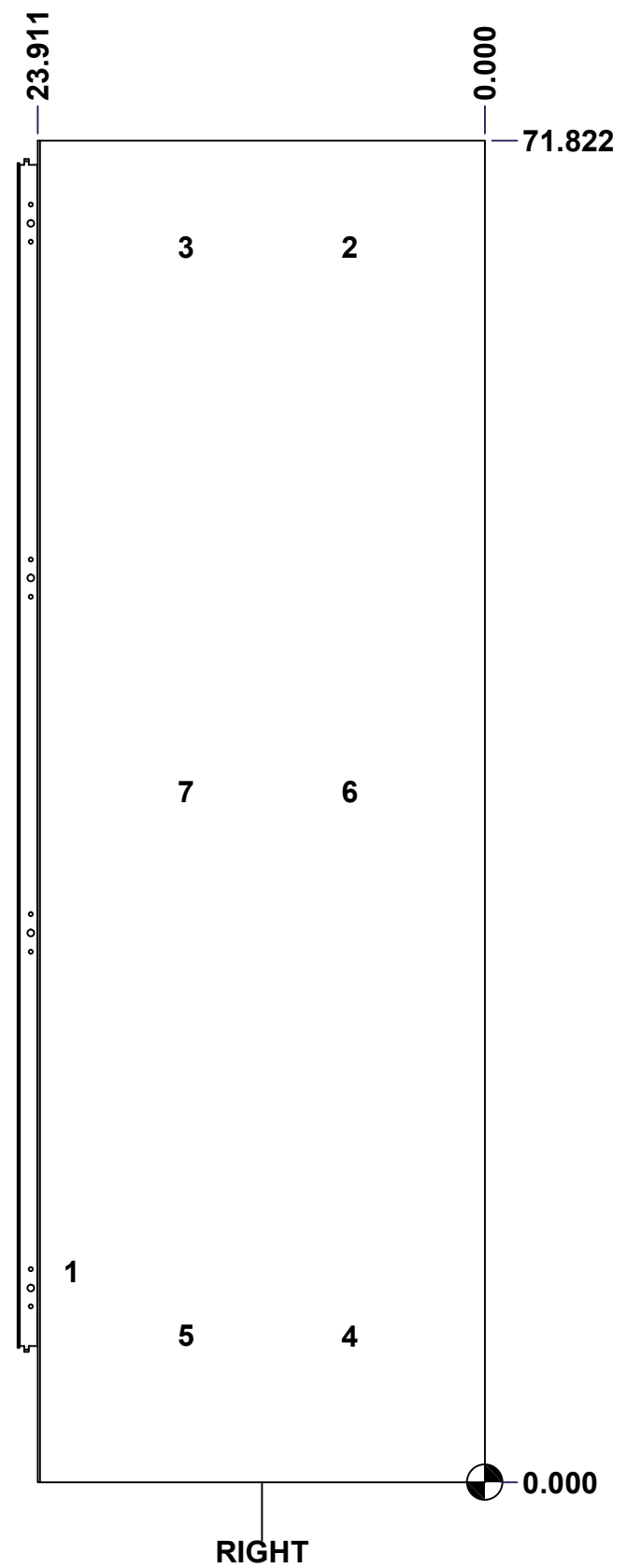

RIGHT

	Description	Status
	9500DD 72" x 60" x 24" Body	(NULL)
	Part Number Numéro Pièce	Rev.
	9500DD726024B	0 / 5
		15

This drawing is confidential and must not be reproduced or used without the consent of EXM

Ce dessin est confidentiel et ne doit pas être reproduit ou utilisé sans le consentement de EXM

STANDARD FEATURES ARE NOT LISTED IN THIS HOLE TABLE

HOLE TABLE - BOTTOM VIEW (CUSTOM FEATURE ONLY)

CUT-OUT	XDIM	YDIM	DESCRIPTION
1	7.286	3.411	GP STUD M6 x 16mm (Inside)
2	16.536	3.411	GP STUD M6 x 16mm (Inside)
3	43.286	3.411	GP STUD M6 x 16mm (Inside)
4	52.536	3.411	GP STUD M6 x 16mm (Inside)

5	28.982	7.536	STUDS M6 x 10mm (Inside)
6	28.982	16.286	STUDS M6 x 10mm (Inside)

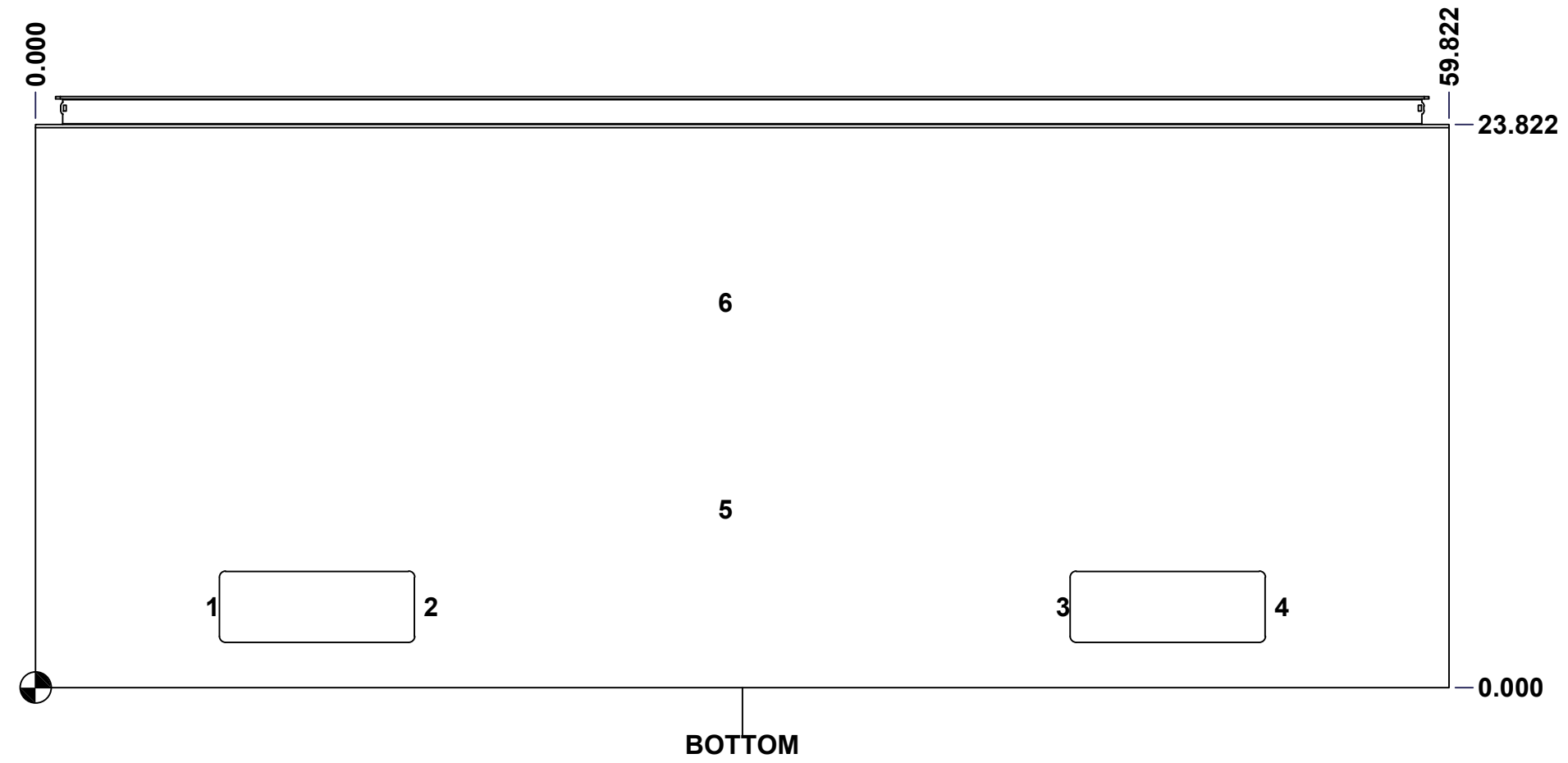

	Description	Status
	9500DD 72" x 60" x 24" Body	(NULL)
Part Number Numéro Pièce	9500DD726024B	Rev. 6
		0 15

This drawing is confidential and must not be reproduced or used without the consent of EXM

Ce dessin est confidentiel et ne doit pas être reproduit ou utilisé sans le consentement de EXM

STANDARD FEATURES ARE NOT LISTED IN THIS HOLE TABLE

HOLE TABLE - LEFT VIEW (CUSTOM FEATURE ONLY)

CUT-OUT	XDIM	YDIM	DESCRIPTION
1	22.411	11.286	GND STUD M6 x 16mm (Inside)
2	7.536	66.107	STUDS M6 x 10mm (Inside)
3	16.286	66.107	STUDS M6 x 10mm (Inside)
4	7.536	7.857	STUDS M6 x 10mm (Inside)
5	16.286	7.857	STUDS M6 x 10mm (Inside)
6	7.536	36.982	STUDS M6 x 10mm (Inside)
7	16.286	36.982	STUDS M6 x 10mm (Inside)

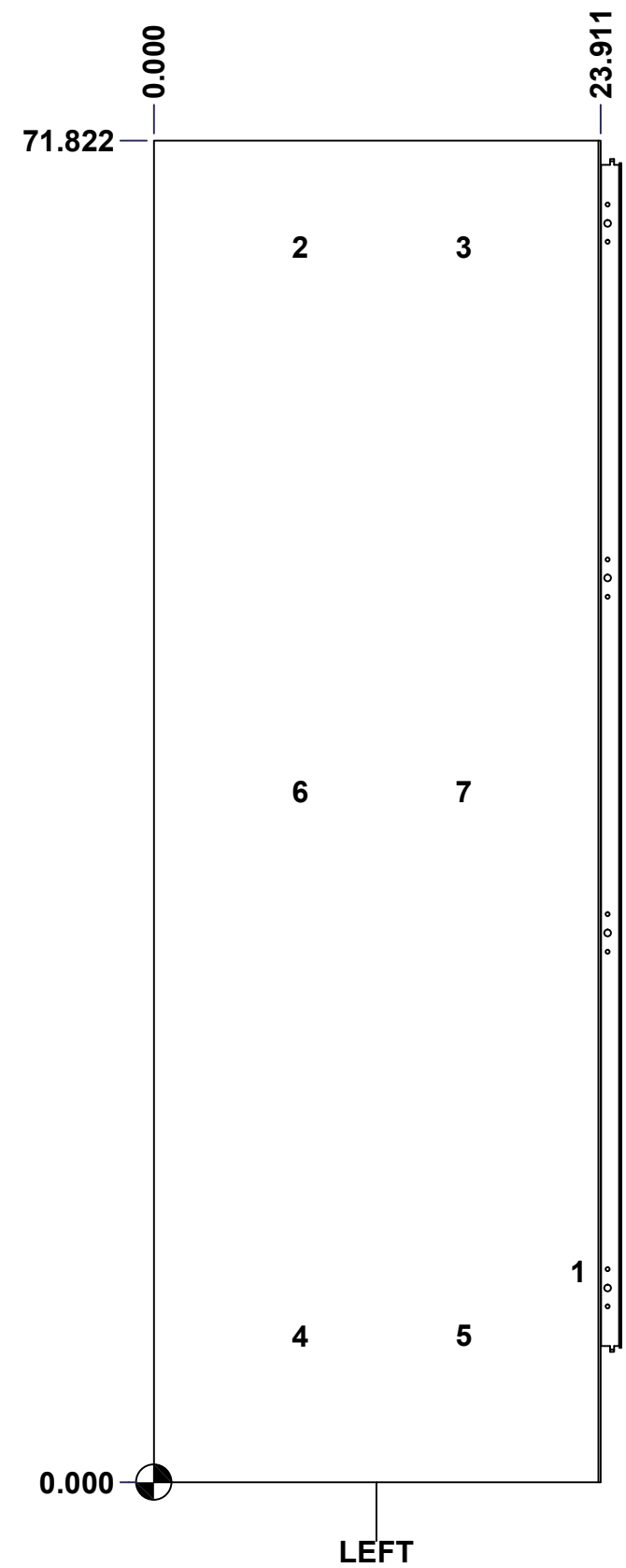

	Description	Status
	9500DD 72" x 60" x 24" Body	(NULL)
	Part Number Numéro Pièce	Rev.
	9500DD726024B	0 / 7
		15

This drawing is confidential and must not be reproduced or used without the consent of EXM

Ce dessin est confidentiel et ne doit pas être reproduit ou utilisé sans le consentement de EXM

No.	Revisions	Date	By/Par

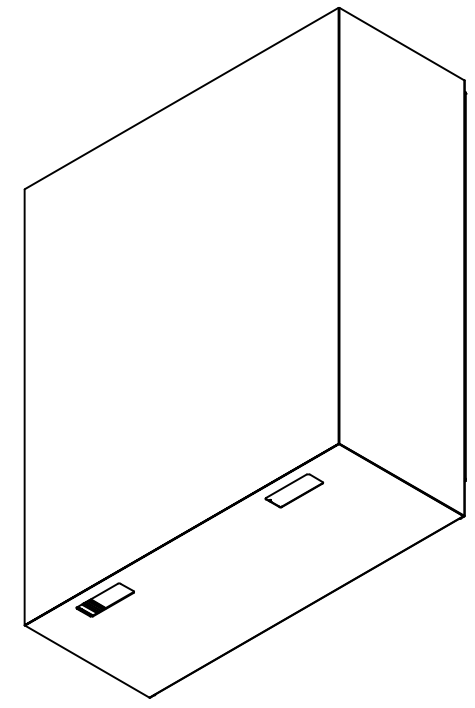

Isometric View

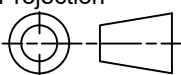

Qty	Part Number	Rev	Description
20	STK-Q-16030	0	Stud M6 x 10mm Steel
2	STK-Q-74910	0	Eyebolt Lifting Angle (15.500")
1	STK-P-02400S	0	Powder Paint (Asa-61 Grey / Smooth)
1	STK-Q-52200-24	2	Sasco Strut S5 (21.500" Long)
7	STK-Q-52250-24	2	Sasco Strut S5 (23.500" Long)
1	9500DD726024BT-P	0	9500DD 60" x 24" Bottom Part
1	9500DD726024T-P	0	9500DD 60" x 24" Top Part
1	9500DD726024RS-P	0	9500DD 72" x 60" Right Part
1	9500DD726024LS-P	0	9500DD 72" x 60" Left Part
1	9500DD726024B-P	0	9500DD 72" x 60" Back Part
2	CR400MS_21.5	0	Commercial Roll Mild Steel (21.5in long)
6	STK-Q-16080	0	Ground Stud M6 x 16mm Steel
Parts List			

 Tél: (450) 979-4373 Fax: (450) 979-4626 www.exmweb.com		Flatness Aplatissement Max 3.0mm Projection 
Customer Client	Date	
Drawn By Dessiné Par	BoxCad: BoxCad	Date 15-Sep-14
Material Matière	12 Ga Cold Rolled A1008 CS Type B (2.5mm)	
Color Couleur	Asa-61 Grey	Finish Fini Smooth
Description		Detail Rev.
9500DD 72" x 60" x 24" Body		
Part Number Numéro Pièce	Rev.	8
9500DD726024B	0	15

This drawing is confidential and must not be reproduced or used without the consent of EXM

Ce dessin est confidentiel et ne doit pas être reproduit ou utilisé sans le consentement de EXM

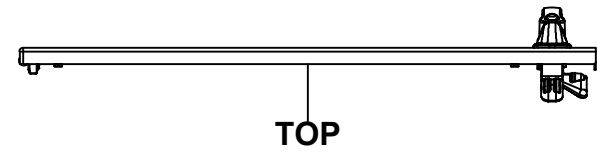

TOP

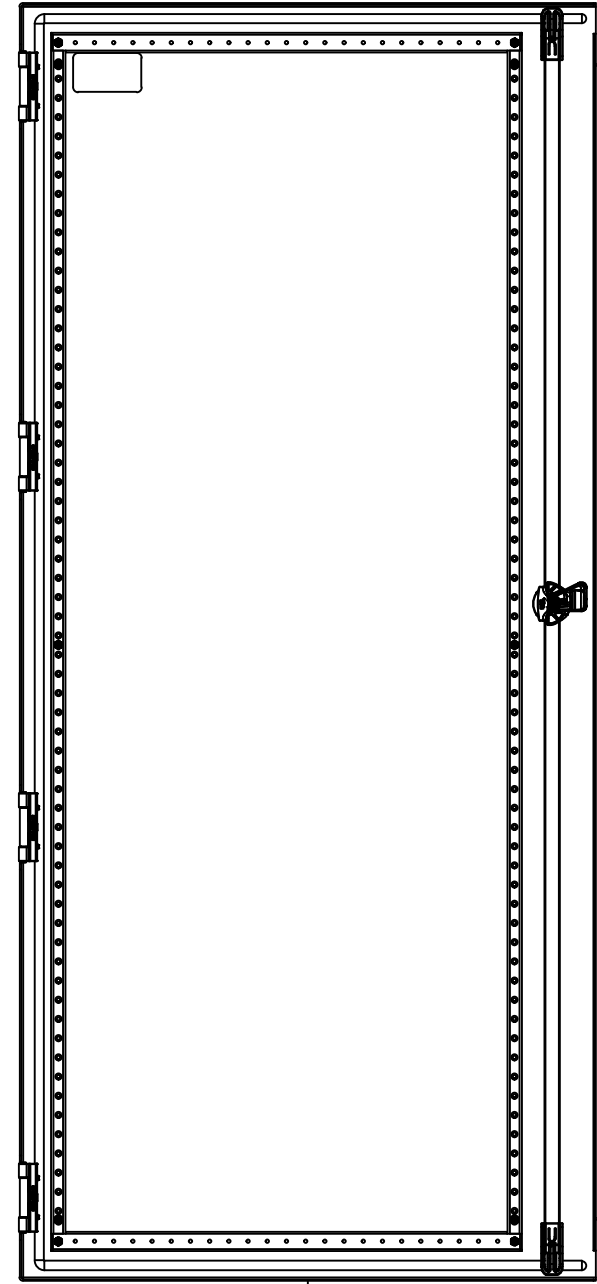

BACK

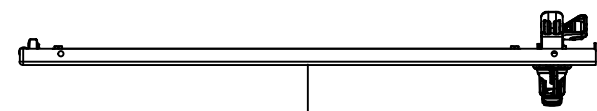

BOTTOM

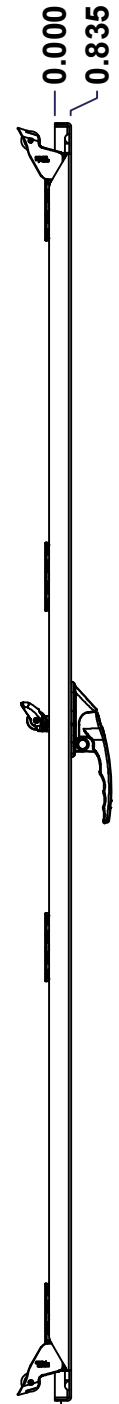

LEFT

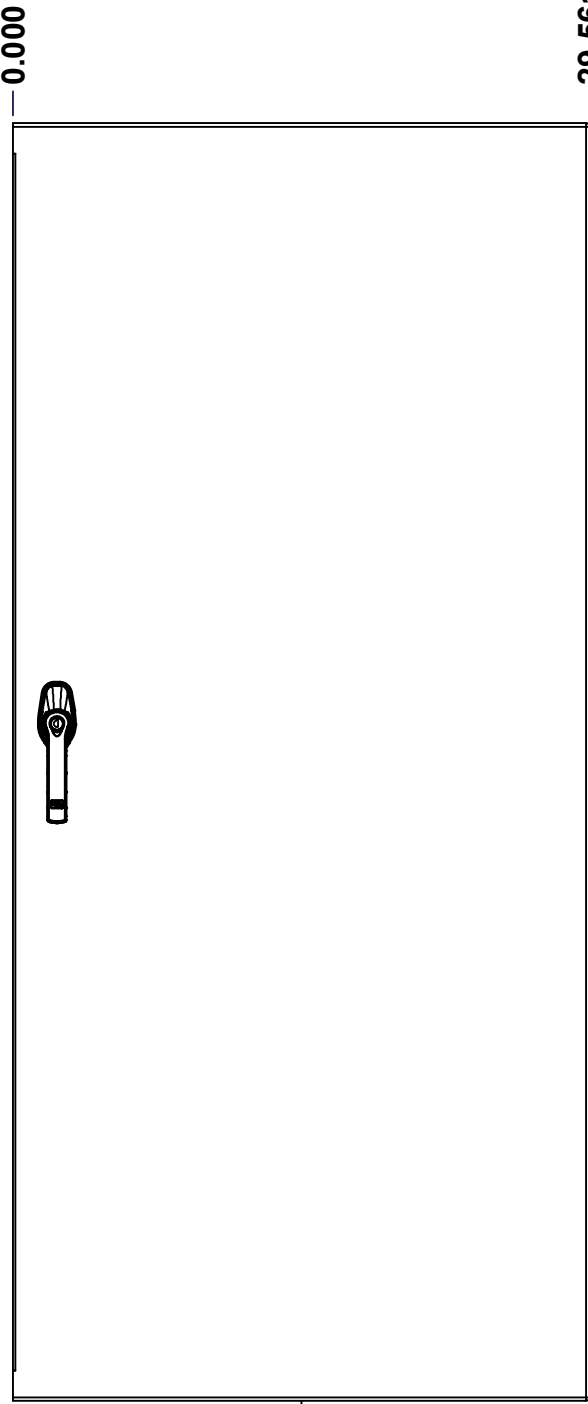

FRONT

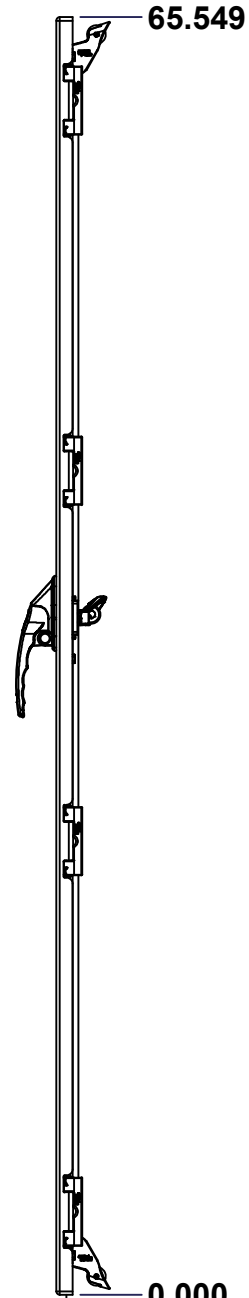

RIGHT

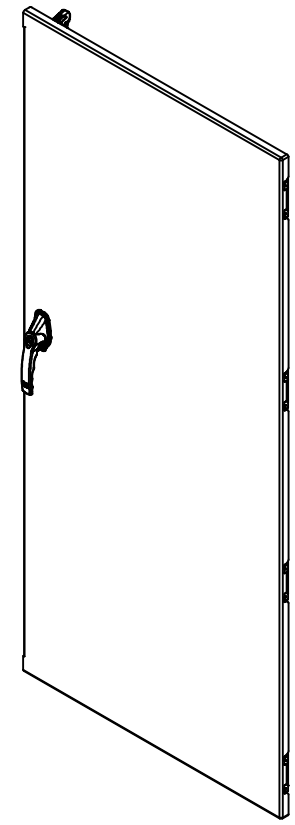

Isometric View

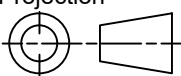

No.	Revisions	Date	By/Par

 Tél: (450) 979-4373 Fax: (450) 979-4626 www.exmweb.com		Flatness Aplatissement Max 3.0mm Projection 
Customer Client	Date	
Drawn By Dessiné Par	BoxCad: BoxCad	Date 15-Sep-14
Material Matière	12 Ga Cold Rolled A1008 CS Type B (2.5mm)	
Color Couleur	Asa-61 Grey	Finish Fini Smooth
Description 9500DD 72" x 60" Lock Door		Detail Rev.
Part Number Numéro Pièce	9500DD726024LD	Rev. 9 0

SEE BILL OF MATERIAL ON LAST PAGE

This drawing is confidential and must not be reproduced or used without the consent of EXM

Ce dessin est confidentiel et ne doit pas être reproduit ou utilisé sans le consentement de EXM

STANDARD FEATURES ARE NOT LISTED IN THIS HOLE TABLE			
HOLE TABLE - FRONT VIEW (CUSTOM FEATURE ONLY)			
CUT-OUT	XDIM	YDIM	DESCRIPTION
1	1.983	2.028	STUD M6 x 18mm (Inside)
2	1.983	32.628	STUD M6 x 18mm (Inside)
3	1.983	63.521	STUD M6 x 18mm (Inside)
4	1.983	3.139	STUD M6 x 18mm (Inside)
5	1.983	62.409	STUD M6 x 18mm (Inside)
6	25.390	2.028	STUD M6 x 18mm (Inside)
7	25.390	32.628	STUD M6 x 18mm (Inside)
8	25.390	63.521	STUD M6 x 18mm (Inside)
9	25.390	3.139	STUD M6 x 18mm (Inside)
10	25.390	62.409	STUD M6 x 18mm (Inside)
11	27.311	6.118	LARGE CBAR GUIDE (Inside)
12	27.311	59.430	LARGE CBAR GUIDE (Inside)
-----	-----	-----	-----
13	27.311	34.743	HANDLE 885 ESL2A-APHK @ 0.0°

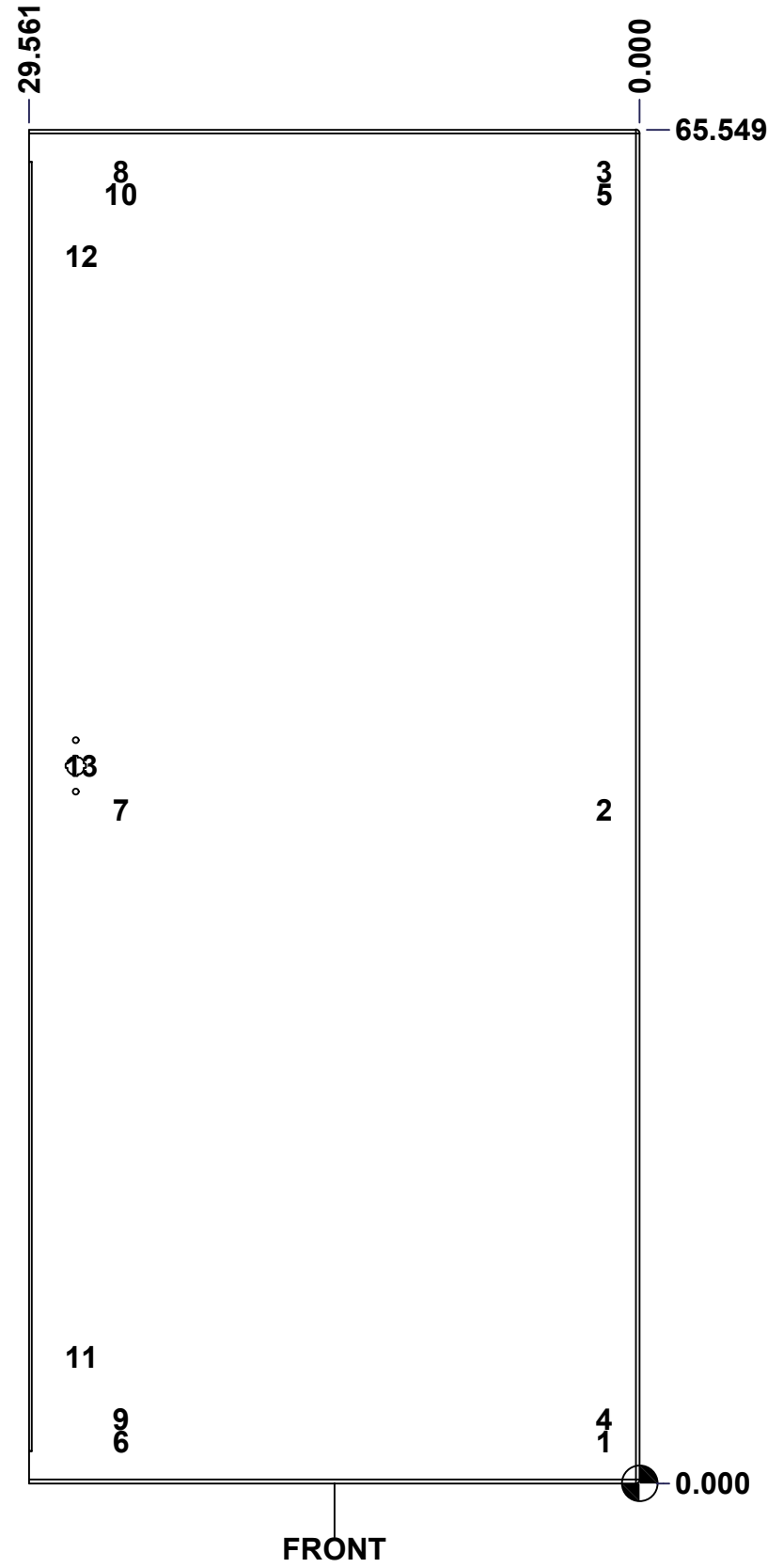

	Description	Status
	9500DD 72" x 60" Lock Door	(NULL)
	Part Number Numéro Pièce	Rev.
	9500DD726024LD	0
		10
		15

This drawing is confidential and must not be reproduced or used without the consent of EXM

Ce dessin est confidentiel et ne doit pas être reproduit ou utilisé sans le consentement de EXM

No.	Revisions	Date	By/Par

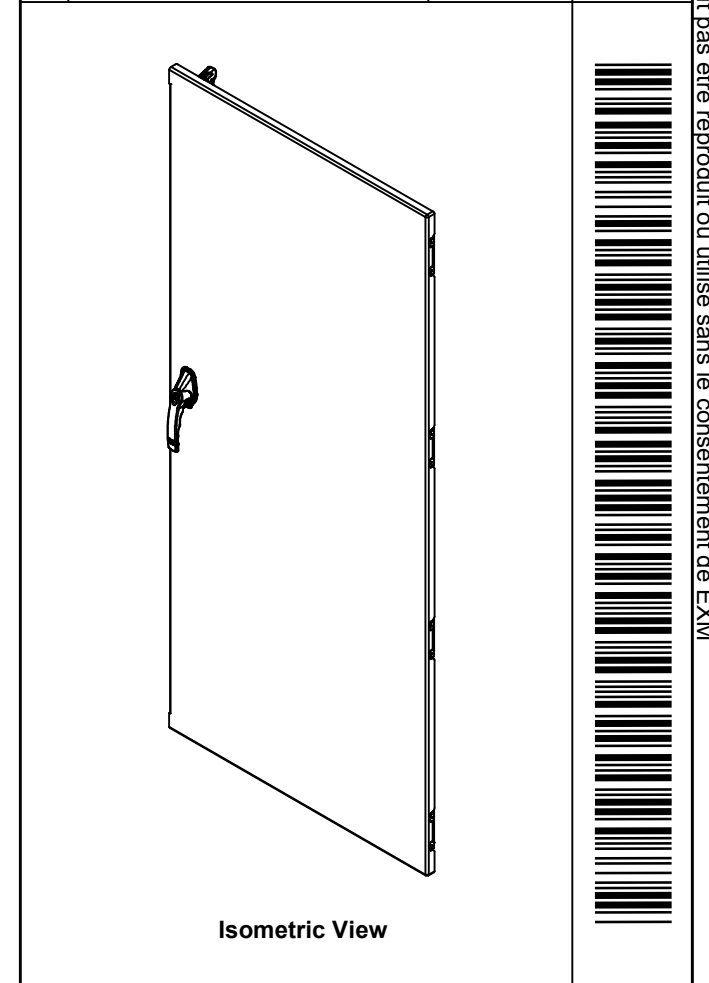

1	STK-Q-47562	0	9500 Lower Closing Bar 72" (cam)
1	STK-Q-47552	0	9500 Upper Closing Bar 72" (cam)
1	STK-A-50537	3	9500 Handle Cam Assembly (Left Side, Grip 36mm)
1	STK-Q-90051	3	5412 ES - Handle Cam Spacer
1	885ESL2A-APHK	6	885 ESL2A-APHK - Zinc Die Cast L-Handle Padlockable Assy
1	STK-P-02400S	0	Powder Paint (Asa-61 Grey / Smooth)
1	STK-S-00100	0	3.5" x 2" Silver Milar Flexcon Sticker
1	STK-K-10840	3	9500 - Door Stiffener Assembly
2	STK-Q-16410	0	Guide Stud - Largel (No Paint Cap Required)
10	STK-Q-16055	1	M6 x 18mm Stud (No Paint Cap Required)
1	9500DD726024LDG	0	9500DD 72" x 60" Lock Door Gasket
1	9500DD726024LD-P	0	9500DD 72" x 60" Lock Door Part
2	STK-A-90025	0	9500 - Cabinet Closing Bar End (Large)
4	STK-K-09860	7	Cabinet Hinge with Captive Pins
2	STK-Q-07220	1	M6 Nylon Insert Lock Nut

QTY	Part Number	Rev	Description
Parts List			

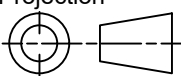
 Tél: (450) 979-4373 Fax: (450) 979-4626 www.exmweb.com	Flatness Aplatissement	Max 3.0mm
	Projection	
Customer Client	Date	
Drawn By Dessiné Par	BoxCad: BoxCad	Date 15-Sep-14
Material Matière	12 Ga Cold Rolled A1008 CS Type B (2.5mm)	
Color Couleur	Asa-61 Grey	Finish Fini Smooth
Description	Detail Rev.	
9500DD 72" x 60" Lock Door		
Part Number Numéro Pièce	Rev.	11
9500DD726024LD	0	15

This drawing is confidential and must not be reproduced or used without the consent of EXM

Ce dessin est confidentiel et ne doit pas être reproduit ou utilisé sans le consentement de EXM



TOP

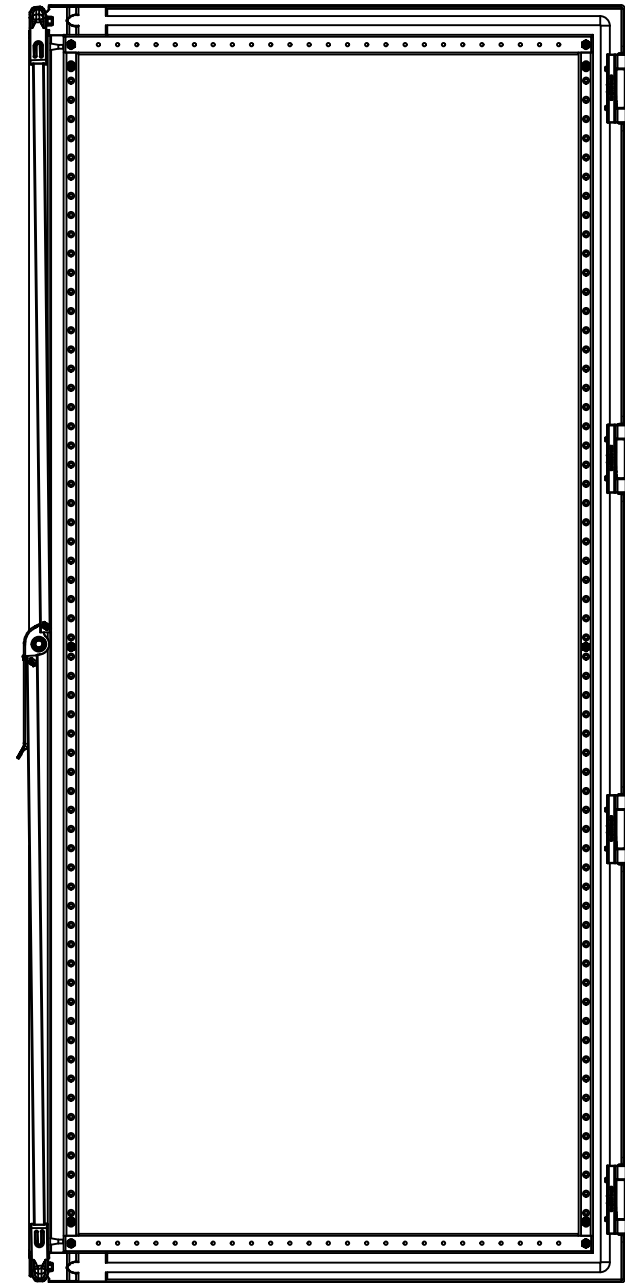

BACK

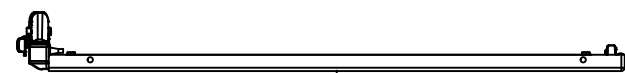

BOTTOM

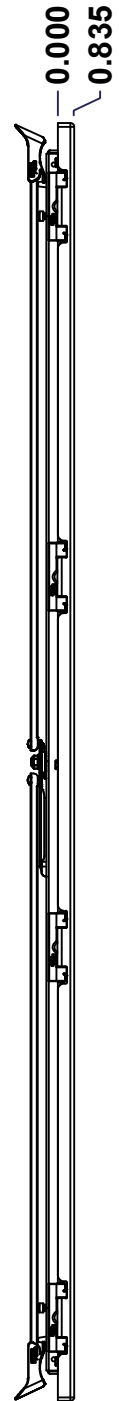

LEFT

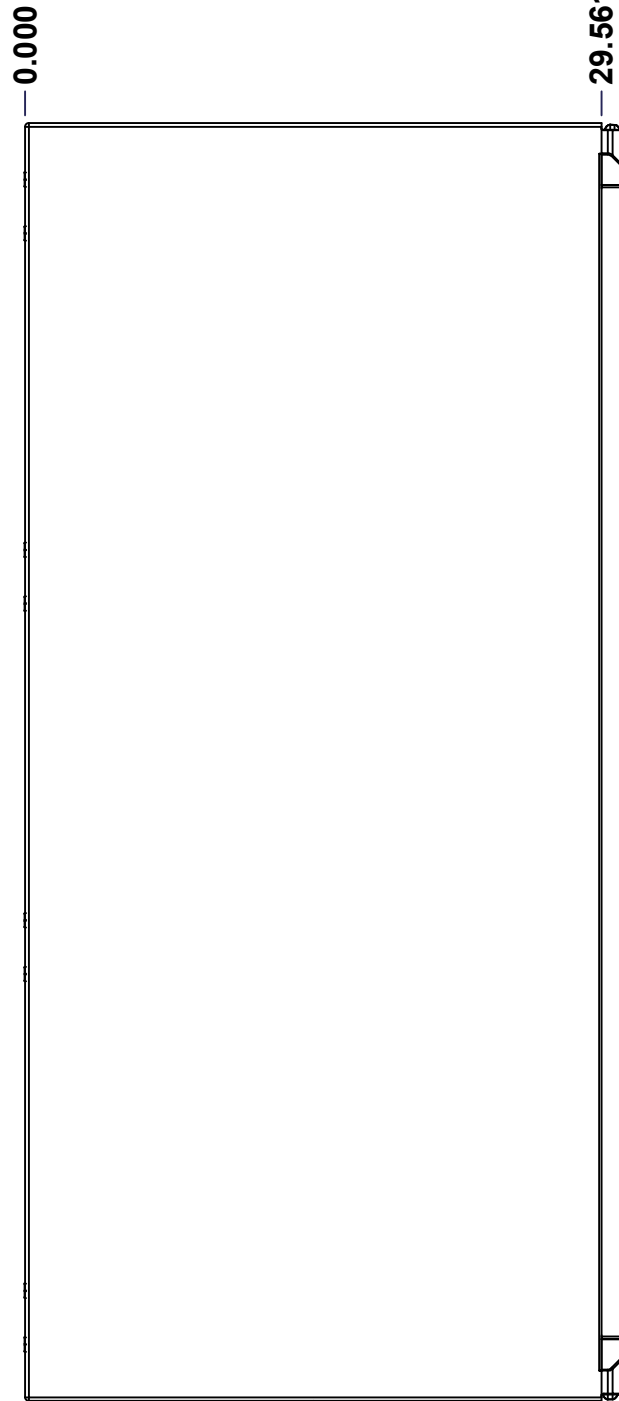

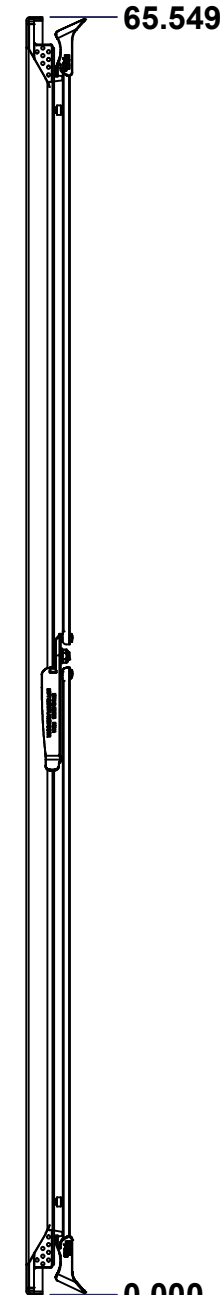

FRONT

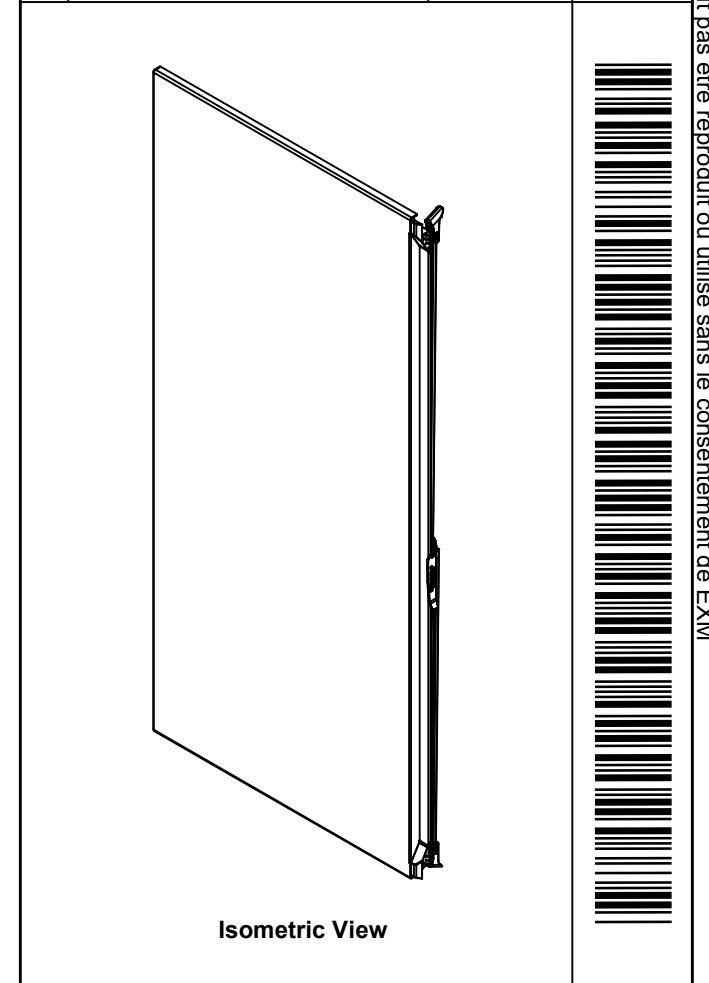

RIGHT

No.	Revisions	Date	By/Par



 Tél: (450) 979-4373 Fax: (450) 979-4626 www.exmweb.com		Flatness Aplatissement
		Max 3.0mm
Customer Client		Date
Drawn By Dessiné Par BoxCad: BoxCad		Date 15-Sep-14
Material Matière 12 Ga Cold Rolled A1008 CS Type B (2.5mm)		
Color Couleur	Asa-61 Grey	Finish Fini Smooth
Description 9500DD 72" x 60" Flange Door		Detail Rev.
Part Number Numéro Pièce 9500DD726024FD		Rev. 12 0 15

SEE BILL OF MATERIAL ON LAST PAGE

This drawing is confidential and must not be reproduced or used without the consent of EXM

Ce dessin est confidentiel et ne doit pas être reproduit ou utilisé sans le consentement de EXM

STANDARD FEATURES ARE NOT LISTED IN THIS HOLE TABLE			
HOLE TABLE - FRONT VIEW (CUSTOM FEATURE ONLY)			
CUT-OUT	XDIM	YDIM	DESCRIPTION
1	2.000	2.028	STUD M6 x 18mm (Inside)
2	2.000	32.628	STUD M6 x 18mm (Inside)
3	2.000	63.521	STUD M6 x 18mm (Inside)
4	2.000	3.139	STUD M6 x 18mm (Inside)
5	2.000	62.409	STUD M6 x 18mm (Inside)
6	28.407	2.028	STUD M6 x 18mm (Inside)
7	28.407	32.628	STUD M6 x 18mm (Inside)
8	28.407	63.521	STUD M6 x 18mm (Inside)
9	28.407	3.139	STUD M6 x 18mm (Inside)
10	28.407	62.409	STUD M6 x 18mm (Inside)
11	30.061	4.774	SMALL CBAR GUIDE (Inside)
12	30.061	60.774	SMALL CBAR GUIDE (Inside)
13	30.061	32.774	STUD M10 x 20mm (Inside)

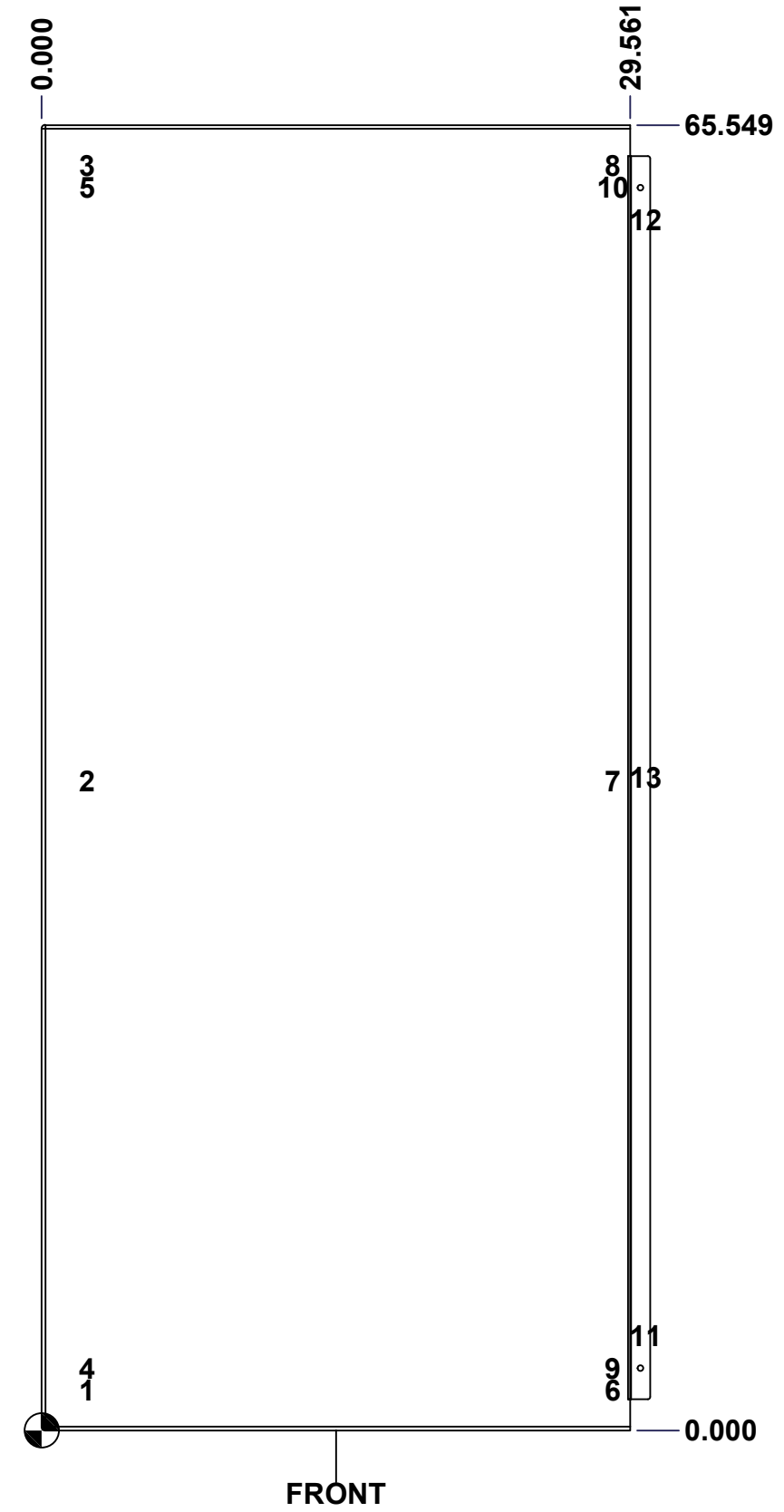

	Description	Status
	9500DD 72" x 60" Flange Door	(NULL)
	Part Number Numéro Pièce	Rev.
	9500DD726024FD	0
		13
		15

This drawing is confidential and must not be reproduced or used without the consent of EXM

Ce dessin est confidentiel et ne doit pas être reproduit ou utilisé sans le consentement de EXM

No.	Revisions	Date	By/Par

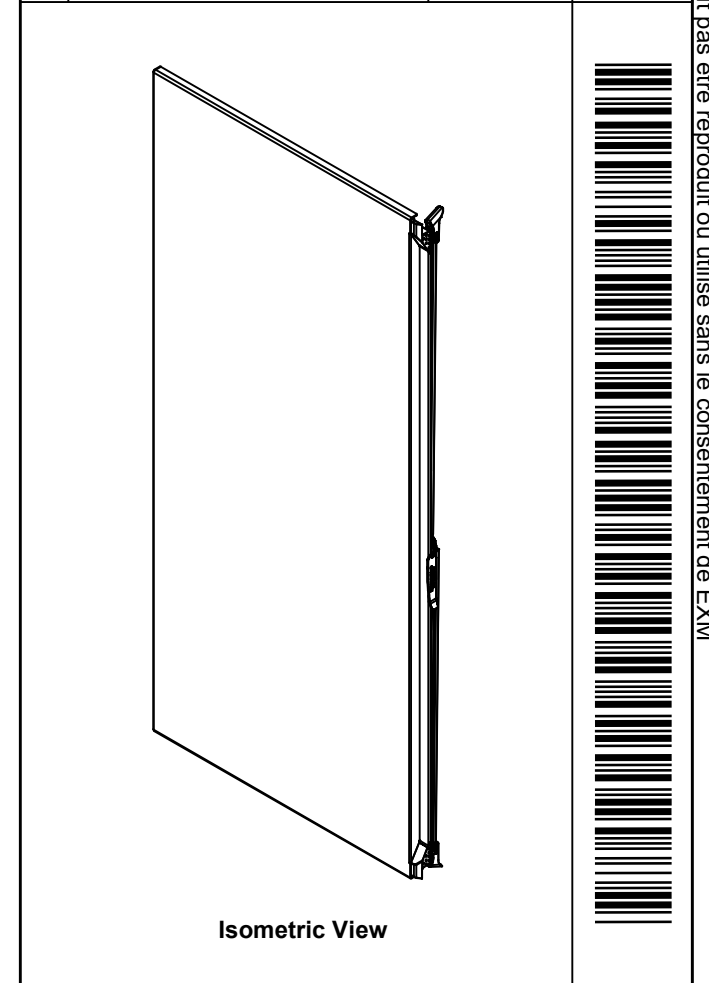

1	STK-P-02400S	0	Powder Paint (Asa-61 Grey / Smooth)
1	STK-G-03400	1	5500 DD Lower Flange Door Gasket
1	STK-G-03300	2	5500 DD Upper Flange Door Gasket
2	STK-Q-90045	0	Cabinet - Closing Bar End
2	STK-Q-45660-72	2	9500 DD - Flange Door Closing Bar
1	STK-K-50556	4	9500 DD - Flange Door Handle Assy
1	STK-K-20840	3	9500 - Flange Door Stiffener Assembly
1	STK-Q-16122	2	Stud M10 x 20mm
2	STK-Q-16405	7	Guide Stud - Small (No Paint Cap Required)
10	STK-Q-16055	1	M6 x 18mm Stud (No Paint Cap Required)
1	STK-G-00701	0	1" x 1/4" Self-Adhesive Neoprene Gasket
1	9500DD726024FDG	0	9500DD 72" x 60" Flange Door Gasket
1	9500DD726024FD-P	0	9500DD 72" x 60" Flange Door Part
4	STK-K-09860	7	Cabinet Hinge with Captive Pins

QTY	Part Number	Rev	Description
Parts List			

	Flatness Aplatissement Max 3.0mm
	Projection
Customer Client	Date
Drawn By Dessiné Par BoxCad: BoxCad	Date 15-Sep-14
Material Matière 12 Ga Cold Rolled A1008 CS Type B (2.5mm)	
Color Couleur Asa-61 Grey	Finish Fini Smooth
Description 9500DD 72" x 60" Flange Door	
Detail Rev.	
Part Number Numéro Pièce 9500DD726024FD	Rev. 14 0 15

All knockouts are actual size / Les disques défonçables sont grandeur réel
 All dimensions are before paint / Toutes les dimensions sont avant peinture

This drawing is confidential and must not be reproduced or used without the consent of EXM

Ce dessin est confidentiel et ne doit pas être reproduit ou utilisé sans le consentement de EXM

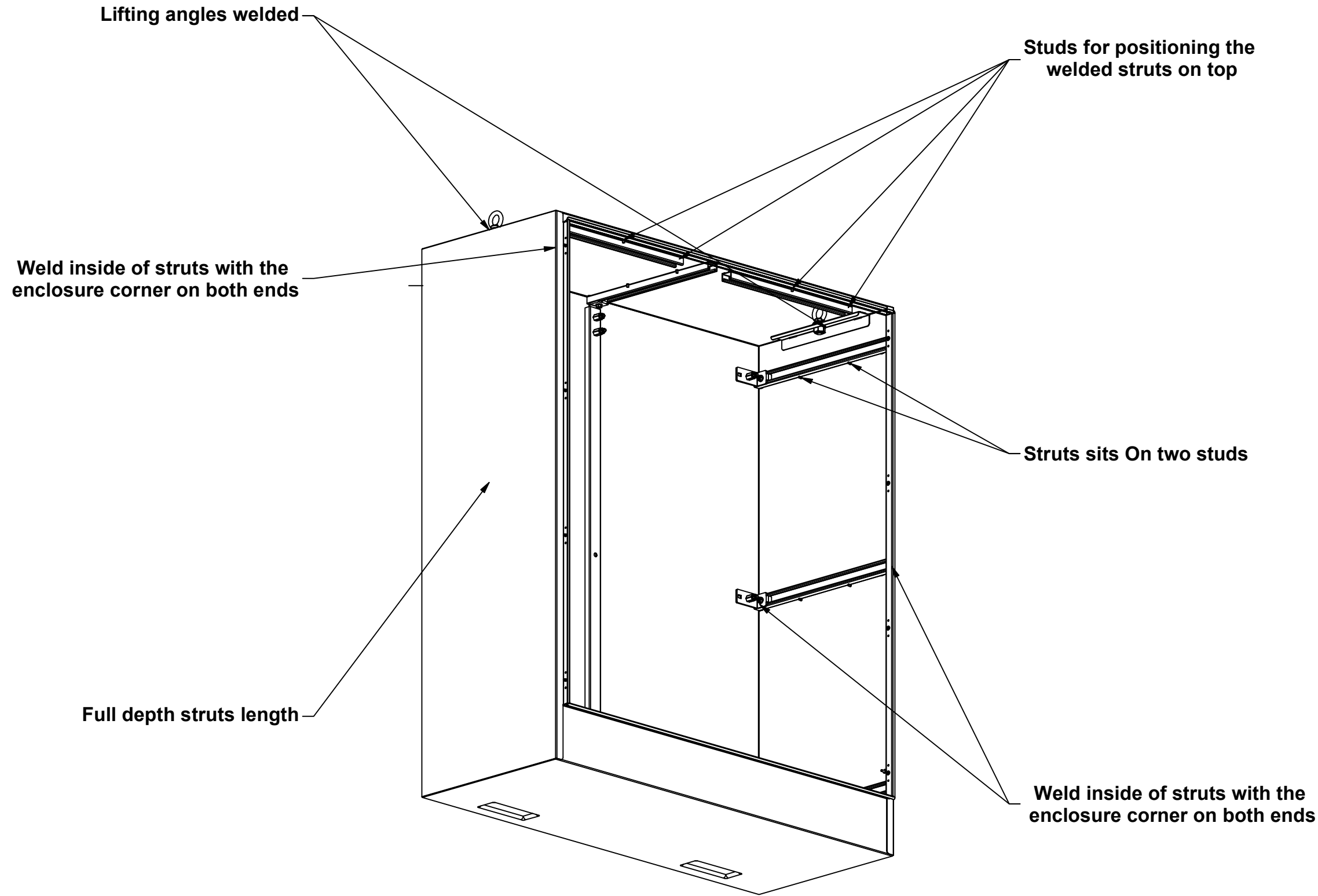

No.	Revisions	Date	By/Par

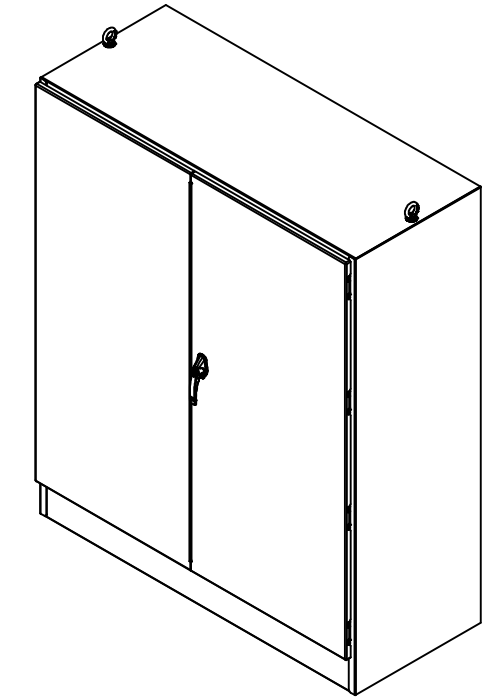

Isometric View

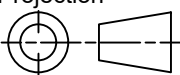

 Tél: (450) 979-4373 Fax: (450) 979-4626 www.exmweb.com		Flatness Aplatissement Max 3.0mm Projection 
Customer Client	Date	
Drawn By Dessiné Par	BoxCad	Date 11-Aug-05
Material Matière	12 Ga Cold Rolled A1008 CS Type B (2.5mm)	
Color Couleur	Asa-61 Grey	Finish Fini Smooth
Description 9500DD 72" x 60" x 24" Assembly		Detail Rev.
Part Number Numéro Pièce	9500DD Welding Details	Rev. 15 0 15