

This drawing is confidential and must not be reproduced or used without the consent of EXM

Ce dessin est confidentiel et ne doit pas être reproduit ou utilisé sans le consentement de EXM

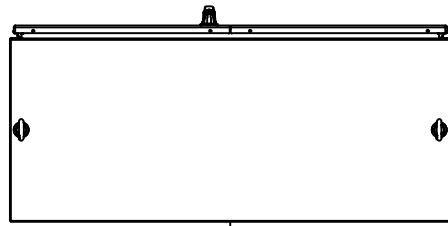

TOP

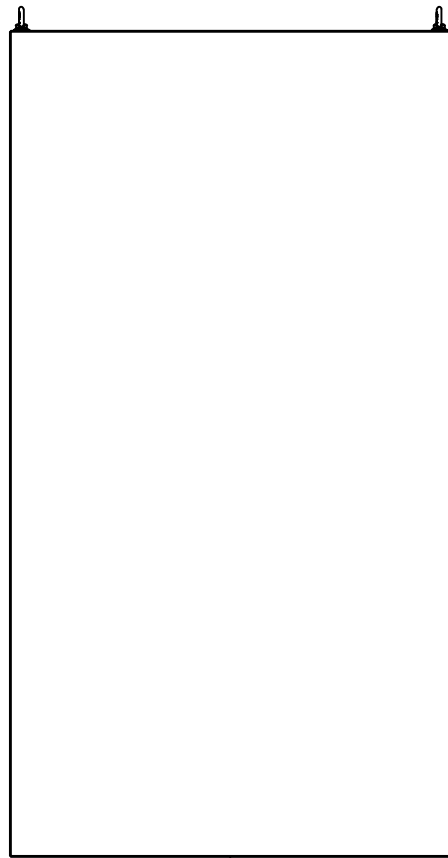

BACK

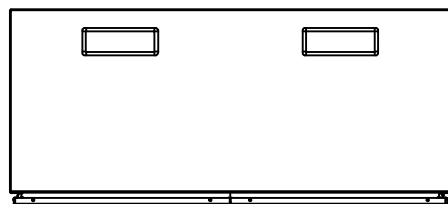

BOTTOM

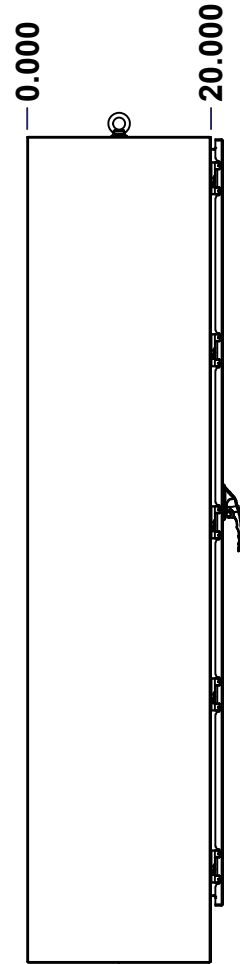

LEFT

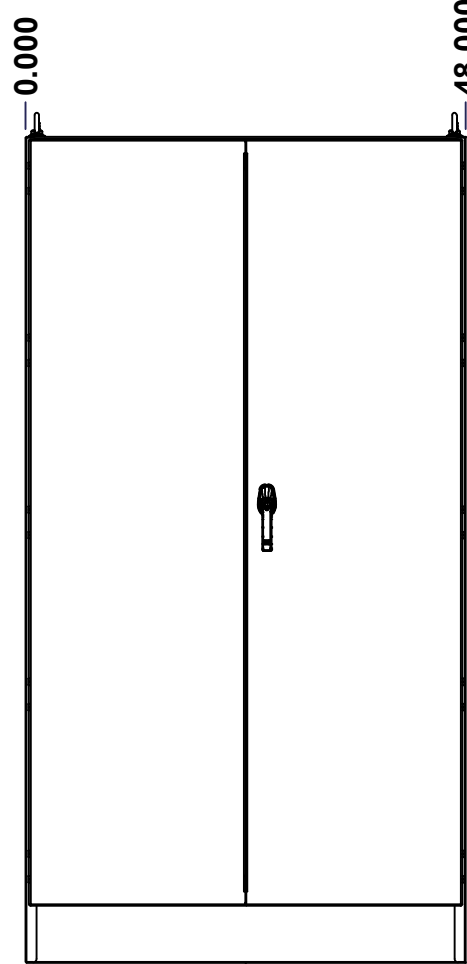

FRONT

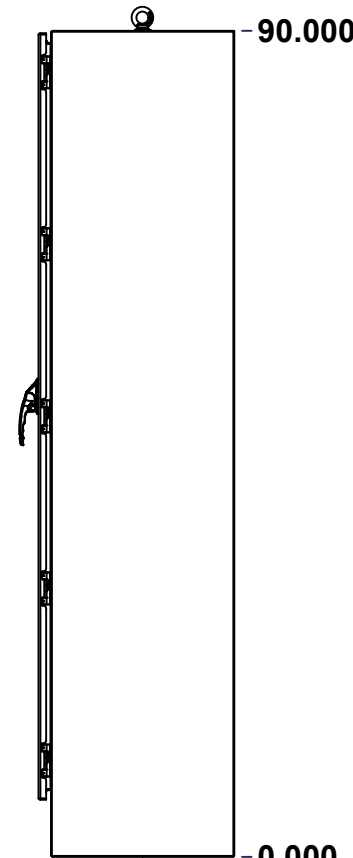

RIGHT

No.	Revisions	Date	By/Par

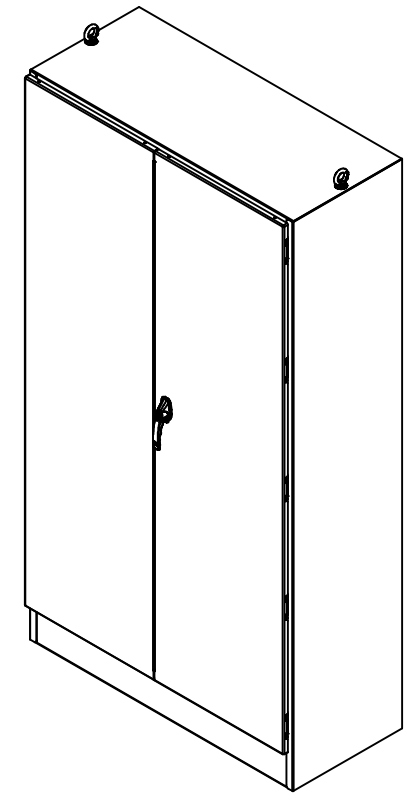

Isometric View

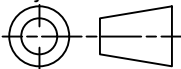

 Tél: (450) 979-4373 Fax: (450) 979-4626 <a href="http://www.exmweb.com">www.exmweb.com</a>		Flatness Aplatissement Max 3.0mm Projection 
Customer Client	Date	
Drawn By Dessiné Par	BoxCad: BoxCad	Date 16-Sep-14
Material Matière	12 Ga Cold Rolled A1008 CS Type B (2.5mm)	
Color Couleur	Asa-61 Grey	Finish Fini Smooth
Description 9500DD 90" x 48" x 20" Assembly		Detail Rev.
Part Number Numéro Pièce	9500DD904820	Rev. 1 0

SEE BILL OF MATERIAL ON LAST PAGE

This drawing is confidential and must not be reproduced or used without the consent of EXM

Ce dessin est confidentiel et ne doit pas être reproduit ou utilisé sans le consentement de EXM

NOTE	
ITEM	DESCRIPTION
1	NEMA 12, 13 Enclosure (IP55)
2	C/W Standard ground studs on box and cover
3	C/W Standard door stiffener
4	W/O Inner panel
5	C/W Standard inner panel mounting struts
6	C/W Struts installed (Included)
7	C/W Eyebolts sold separately (Installed by EXM)

No.	Revisions	Date	By/Par

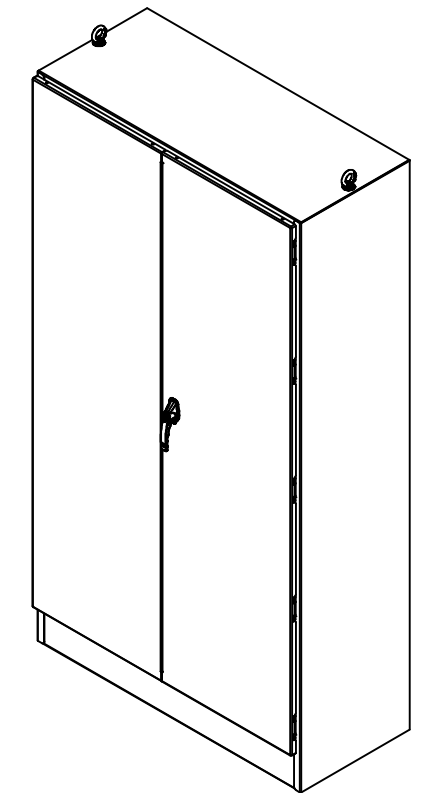

Isometric View

PACKING		
ITEM	QTY	DESCRIPTION
Cardboard sleeve	2	Top and Bottom
Cardboard strip	2	Between back of enclosure and inner panel
Plastic bag	1	To protect cover surface and inside gasket
Cardboard corner	4	To reinforced for the plastic strap tightening
Plastic strap - Black	2	To Squeeze 2 cardboard sleeve together
Packaging label	3	White label with PN
Plastic strap- Green	2	To secure the enclosure to the wood pallet
Wood Pallet	1	2" deeper and 3" larger than enclosure size

1	880EB14	2	Eye Bolt M14 (Pack of 2)
1	889BPS	0	Inner Panel Strut Mounting Kit
1	9500DD904820FD	0	9500DD 90" x 48" Flange Door
1	9500DD904820LD	0	9500DD 90" x 48" Lock Door
1	9500DD904820B	0	9500DD 90" x 48" x 20" Body
2	9500DD904820GP	0	9500DD Gland Plate
10	STK-Q-04050-10	8	M6 x 10mm Hexagon Socket Head Machine Screw with Nyseal
Qty	Part Number	Rev	Description
Parts List			

<p>Tél: (450) 979-4373 Fax: (450) 979-4626 <a href="http://www.exmweb.com">www.exmweb.com</a></p>	Flatness Aplatissement	Max 3.0mm
	Projection	
Customer Client	Date	
Drawn By Dessiné Par	BoxCad: BoxCad	Date 16-Sep-14
Material Matière	12 Ga Cold Rolled A1008 CS Type B (2.5mm)	
Color Couleur	Asa-61 Grey	Finish Fini Smooth
Description	9500DD 90" x 48" x 20" Assembly	Detail Rev.
Part Number Numéro Pièce	<b>9500DD904820</b>	Rev. <b>0</b>
		2 / 15

This drawing is confidential and must not be reproduced or used without the consent of EXM

Ce dessin est confidentiel et ne doit pas être reproduit ou utilisé sans le consentement de EXM

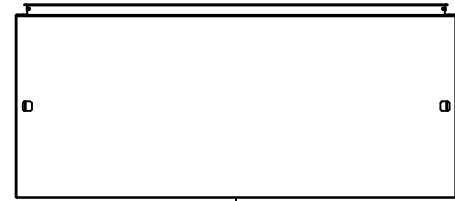

TOP

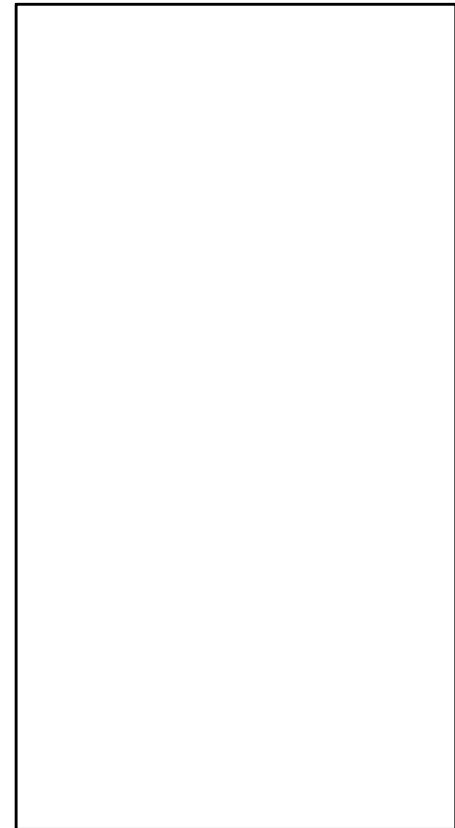

BACK

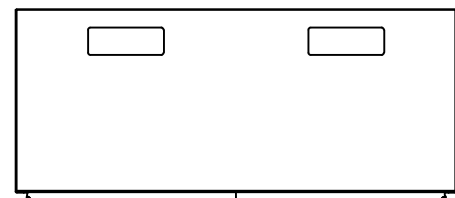

BOTTOM

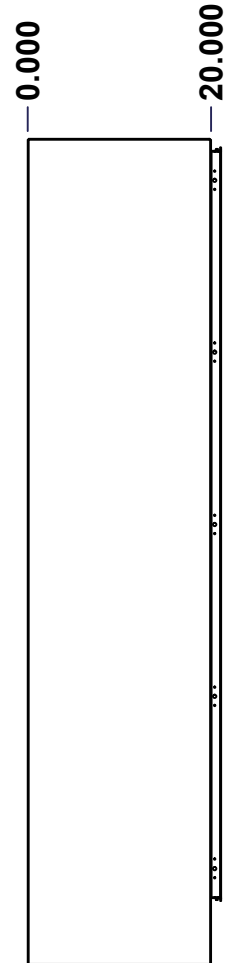

LEFT

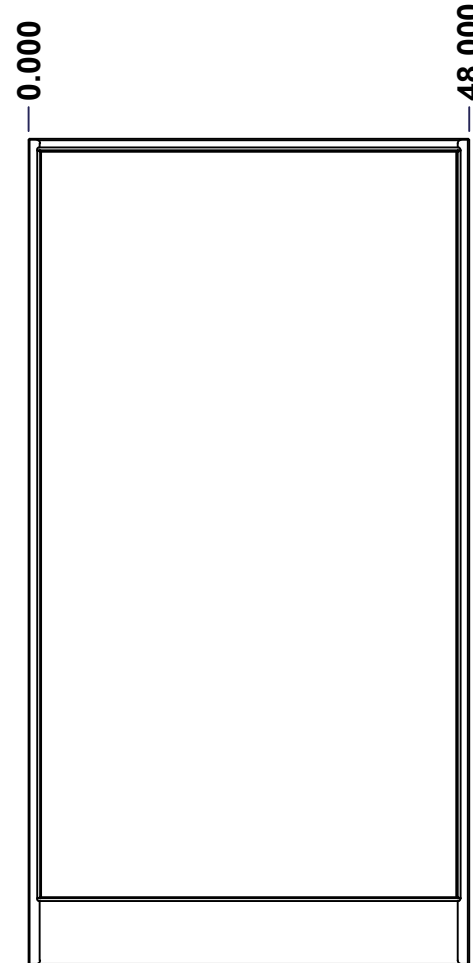

FRONT

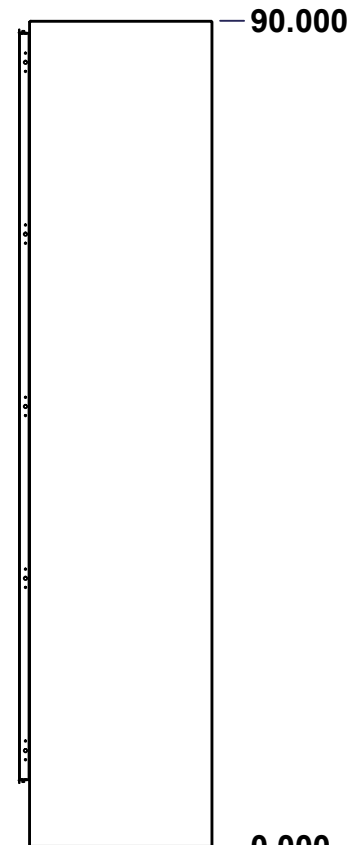

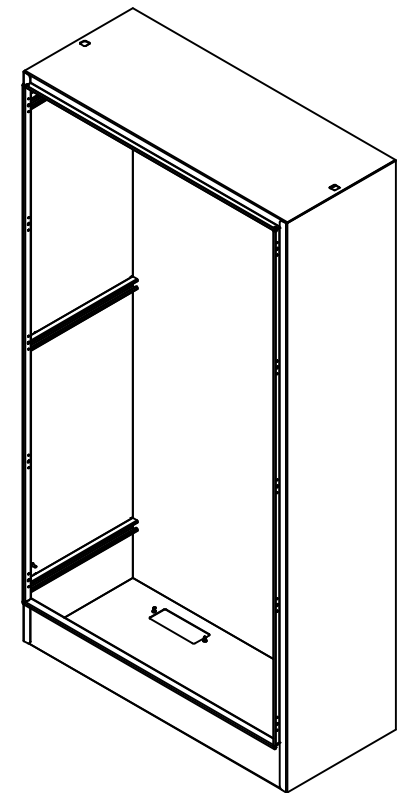

RIGHT



Isometric View

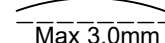

No.	Revisions	Date	By/Par

 Tél: (450) 979-4373 Fax: (450) 979-4626 <a href="http://www.exmweb.com">www.exmweb.com</a>		Flatness Aplatissement  Max 3.0mm Projection 
Customer Client	Date	
Drawn By Dessiné Par	BoxCad: BoxCad	Date 16-Sep-14
Material Matière	12 Ga Cold Rolled A1008 CS Type B (2.5mm)	
Color Couleur	Asa-61 Grey	Finish Fini Smooth
Description	Detail Rev.	
9500DD 90" x 48" x 20" Body		
Part Number Numéro Pièce	Rev.	3
<b>9500DD904820B</b>	<b>0</b>	15

SEE BILL OF MATERIAL ON LAST PAGE

This drawing is confidential and must not be reproduced or used without the consent of EXM

Ce dessin est confidentiel et ne doit pas être reproduit ou utilisé sans le consentement de EXM

**STANDARD FEATURES ARE NOT LISTED IN THIS HOLE TABLE**

**HOLE TABLE - TOP VIEW (CUSTOM FEATURE ONLY)**

CUT-OUT	XDIM	YDIM	DESCRIPTION
1	35.911	15.911	Struts CR400 17.500" (Inside)
2	11.911	15.911	Struts CR400 17.500" (Inside)
3	35.911	16.840	STUDS M6 x 10mm (Inside)
4	44.777	15.911	STUDS M6 x 10mm (Inside)
5	11.911	16.840	STUDS M6 x 10mm (Inside)
6	20.777	15.911	STUDS M6 x 10mm (Inside)

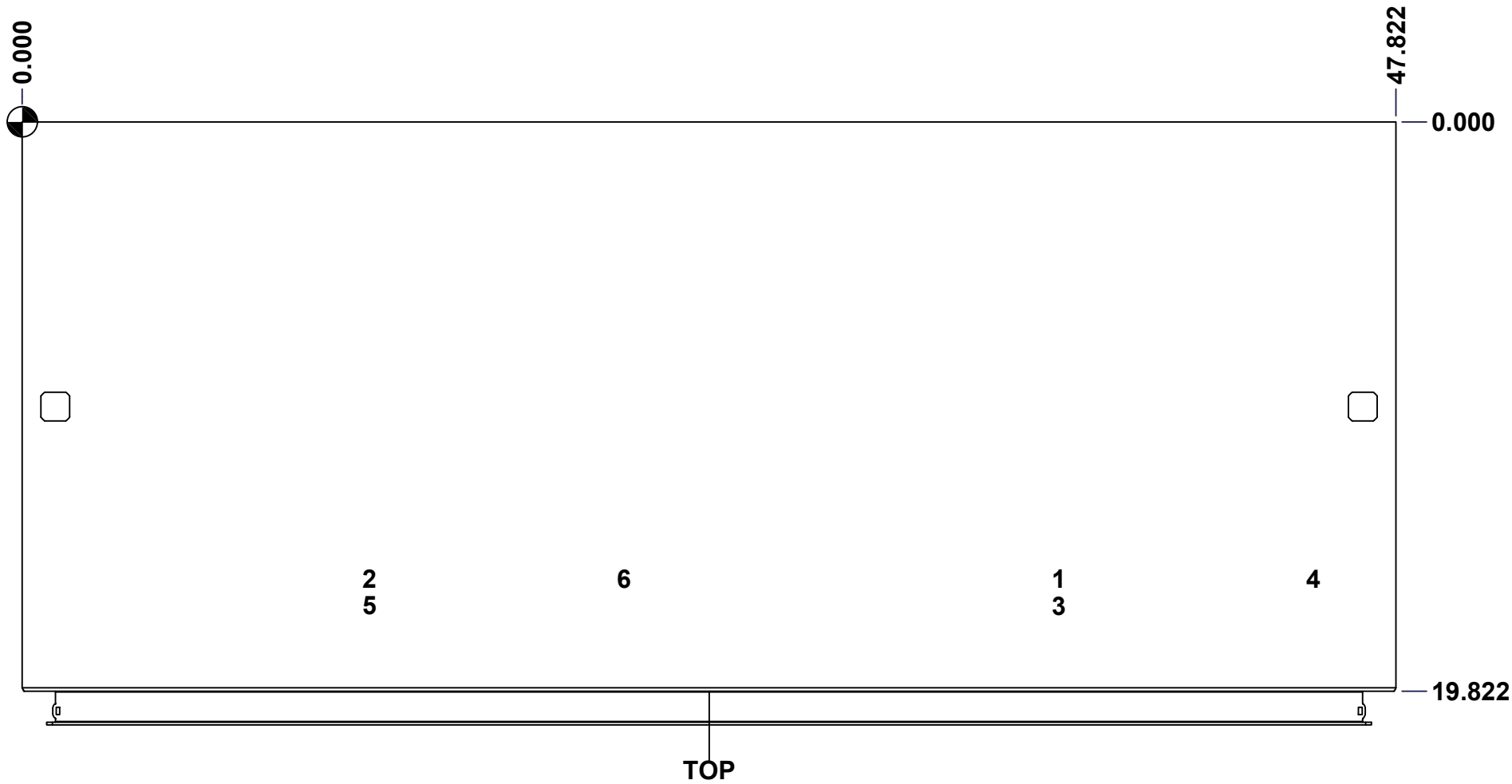

	Description 9500DD 90" x 48" x 20" Body	Status (NULL)
	Part Number Numéro Pièce <b>9500DD904820B</b>	Rev. 4 <b>0</b>

This drawing is confidential and must not be reproduced or used without the consent of EXM

Ce dessin est confidentiel et ne doit pas être reproduit ou utilisé sans le consentement de EXM

**STANDARD FEATURES ARE NOT LISTED IN THIS HOLE TABLE**

**HOLE TABLE - RIGHT VIEW (CUSTOM FEATURE ONLY)**

CUT-OUT	XDIM	YDIM	DESCRIPTION
1	18.411	11.286	GND STUD M6 x 16mm (Inside)
2	6.536	84.107	STUDS M6 x 10mm (Inside)
3	13.286	84.107	STUDS M6 x 10mm (Inside)
4	6.536	7.857	STUDS M6 x 10mm (Inside)
5	13.286	7.857	STUDS M6 x 10mm (Inside)
6	6.536	45.982	STUDS M6 x 10mm (Inside)
7	13.286	45.982	STUDS M6 x 10mm (Inside)

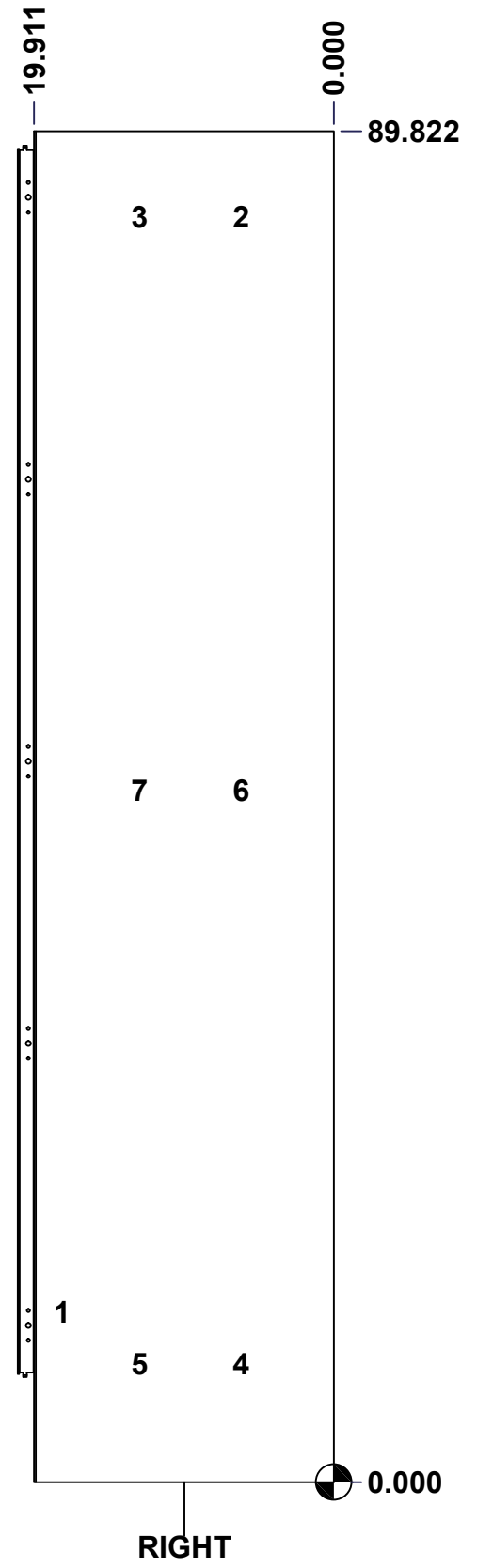

	Description 9500DD 90" x 48" x 20" Body	Status (NULL)
	Part Number Numéro Pièce <b>9500DD904820B</b>	Rev. 5 <b>0</b>

This drawing is confidential and must not be reproduced or used without the consent of EXM

Ce dessin est confidentiel et ne doit pas être reproduit ou utilisé sans le consentement de EXM

**STANDARD FEATURES ARE NOT LISTED IN THIS HOLE TABLE**

**HOLE TABLE - BOTTOM VIEW (CUSTOM FEATURE ONLY)**

CUT-OUT	XDIM	YDIM	DESCRIPTION
1	7.286	3.411	GP STUD M6 x 16mm (Inside)
2	16.536	3.411	GP STUD M6 x 16mm (Inside)
3	31.286	3.411	GP STUD M6 x 16mm (Inside)
4	40.536	3.411	GP STUD M6 x 16mm (Inside)

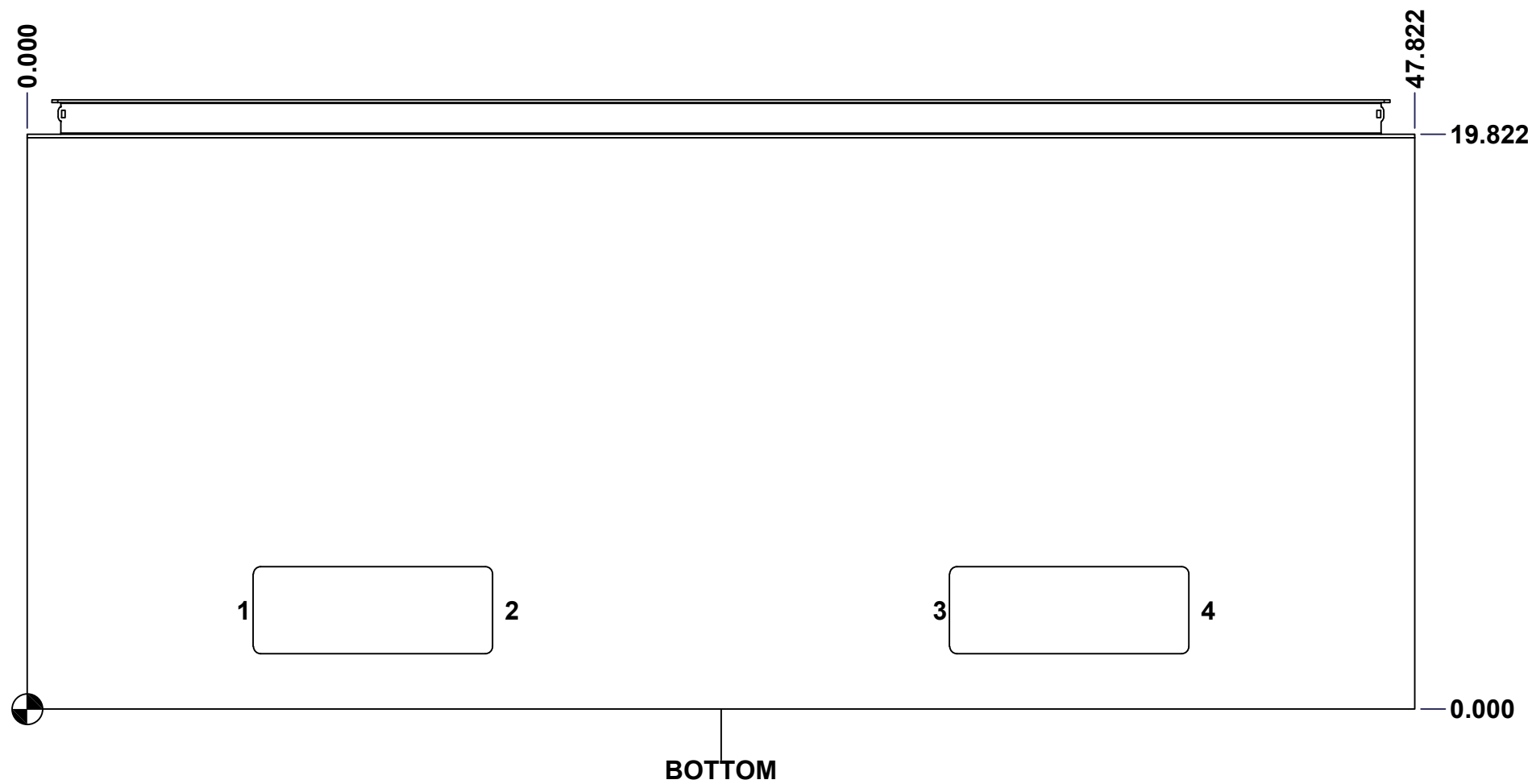

	Description	Status
	9500DD 90" x 48" x 20" Body	(NULL)
	Part Number Numéro Pièce	Rev.
	<b>9500DD904820B</b>	<b>0</b>
		6
		15

This drawing is confidential and must not be reproduced or used without the consent of EXM

Ce dessin est confidentiel et ne doit pas être reproduit ou utilisé sans le consentement de EXM

**STANDARD FEATURES ARE NOT LISTED IN THIS HOLE TABLE**

**HOLE TABLE - LEFT VIEW (CUSTOM FEATURE ONLY)**

CUT-OUT	XDIM	YDIM	DESCRIPTION
1	18.411	11.286	GND STUD M6 x 16mm (Inside)
2	6.536	84.107	STUDS M6 x 10mm (Inside)
3	13.286	84.107	STUDS M6 x 10mm (Inside)
4	6.536	7.857	STUDS M6 x 10mm (Inside)
5	13.286	7.857	STUDS M6 x 10mm (Inside)
6	6.536	45.982	STUDS M6 x 10mm (Inside)
7	13.286	45.982	STUDS M6 x 10mm (Inside)

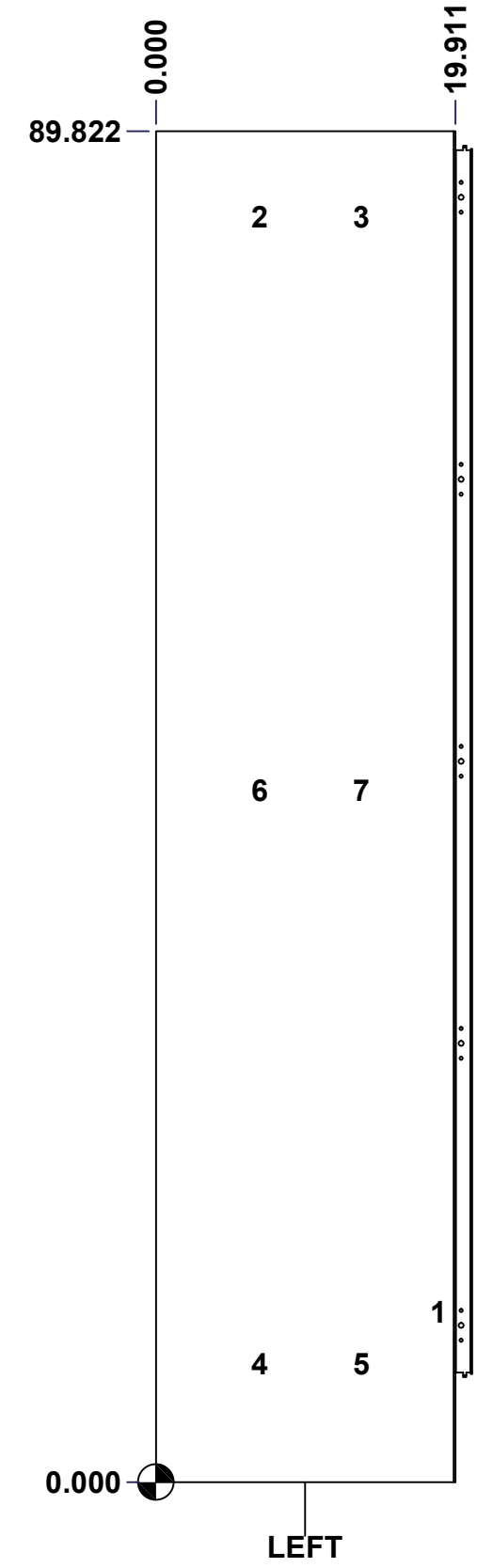

	Description 9500DD 90" x 48" x 20" Body	Status (NULL)
	Part Number Numéro Pièce <b>9500DD904820B</b>	Rev. 7 <b>0</b>

This drawing is confidential and must not be reproduced or used without the consent of EXM

Ce dessin est confidentiel et ne doit pas être reproduit ou utilisé sans le consentement de EXM

No.	Revisions	Date	By/Par

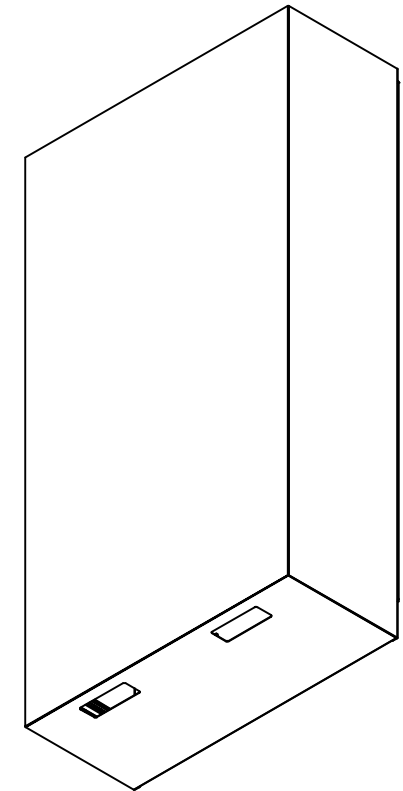

Isometric View



16	STK-Q-16030	0	Stud M6 x 10mm Steel
2	STK-Q-74910	0	Eyebolt Lifting Angle (15.500")
1	STK-P-02400S	0	Powder Paint (Asa-61 Grey / Smooth)
6	STK-Q-52250-20	2	Sasco Strut S5 (19.500" Long)
1	9500DD904820BT-P	0	9500DD 48" x 20" Bottom Part
1	9500DD904820T-P	0	9500DD 48" x 20" Top Part
1	9500DD904820RS-P	0	9500DD 90" x 48" Right Part
1	9500DD904820LS-P	0	9500DD 90" x 48" Left Part
1	9500DD904820B-P	0	9500DD 90" x 48" Back Part
2	CR400MS_17.5	0	Commercial Roll Mild Steel (17.5in long)
6	STK-Q-16080	0	Ground Stud M6 x 16mm Steel

Qty	Part Number	Rev	Description
Parts List			

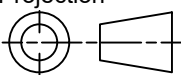
 Tél: (450) 979-4373 Fax: (450) 979-4626 <a href="http://www.exmweb.com">www.exmweb.com</a>		Flatness Aplatissement Max 3.0mm Projection 
Customer Client	Date	
Drawn By Dessiné Par	BoxCad: BoxCad	Date 16-Sep-14
Material Matière	12 Ga Cold Rolled A1008 CS Type B (2.5mm)	
Color Couleur	Asa-61 Grey	Finish Fini Smooth
Description		Detail Rev.
9500DD 90" x 48" x 20" Body		
Part Number Numéro Pièce	Rev.	8
<b>9500DD904820B</b>	<b>0</b>	15

This drawing is confidential and must not be reproduced or used without the consent of EXM

Ce dessin est confidentiel et ne doit pas être reproduit ou utilisé sans le consentement de EXM

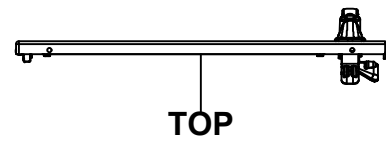

TOP

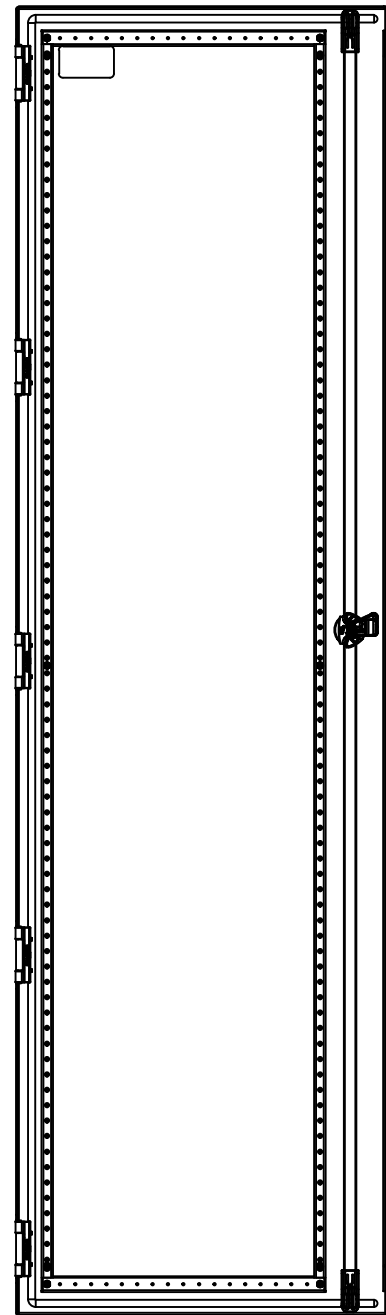

BACK



BOTTOM

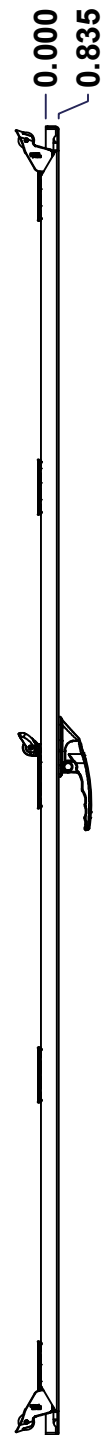

LEFT

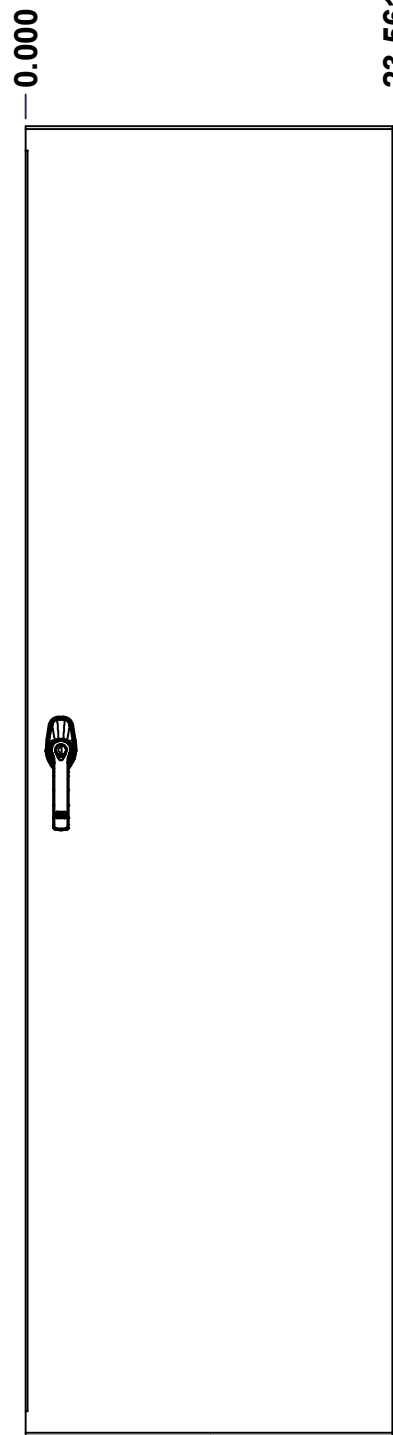

FRONT

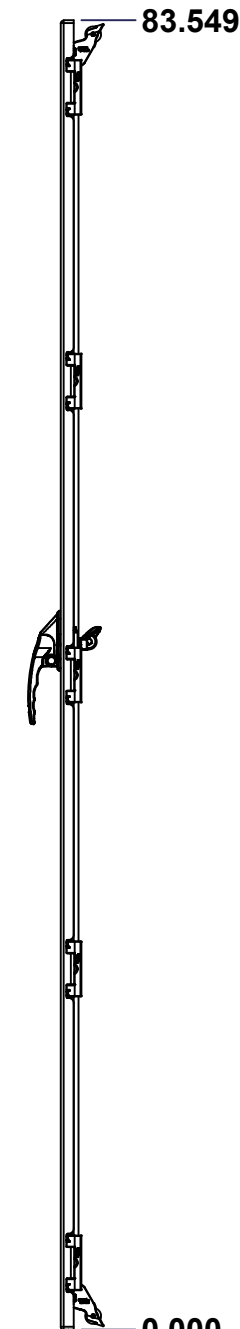

RIGHT

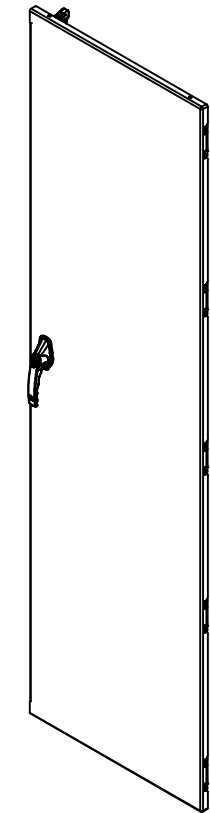

Isometric View

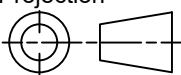

No.	Revisions	Date	By/Par

 Tél: (450) 979-4373 Fax: (450) 979-4626 <a href="http://www.exmweb.com">www.exmweb.com</a>		Flatness Aplatissement Max 3.0mm Projection 
Customer Client	Date	
Drawn By Dessiné Par	BoxCad: BoxCad	Date 16-Sep-14
Material Matière	12 Ga Cold Rolled A1008 CS Type B (2.5mm)	
Color Couleur	Asa-61 Grey	Finish Fini Smooth
Description 9500DD 90" x 48" Lock Door		Detail Rev.
Part Number Numéro Pièce	9500DD904820LD	Rev. 9 0 15

SEE BILL OF MATERIAL ON LAST PAGE

This drawing is confidential and must not be reproduced or used without the consent of EXM

Ce dessin est confidentiel et ne doit pas être reproduit ou utilisé sans le consentement de EXM

STANDARD FEATURES ARE NOT LISTED IN THIS HOLE TABLE			
HOLE TABLE - FRONT VIEW (CUSTOM FEATURE ONLY)			
CUT-OUT	XDIM	YDIM	DESCRIPTION
1	1.983	2.028	STUD M6 x 18mm (Inside)
2	1.983	41.486	STUD M6 x 18mm (Inside)
3	1.983	81.521	STUD M6 x 18mm (Inside)
4	1.983	3.139	STUD M6 x 18mm (Inside)
5	1.983	80.409	STUD M6 x 18mm (Inside)
6	19.390	2.028	STUD M6 x 18mm (Inside)
7	19.390	41.486	STUD M6 x 18mm (Inside)
8	19.390	81.521	STUD M6 x 18mm (Inside)
9	19.390	3.139	STUD M6 x 18mm (Inside)
10	19.390	80.409	STUD M6 x 18mm (Inside)
11	21.311	6.118	LARGE CBAR GUIDE (Inside)
12	21.311	77.430	LARGE CBAR GUIDE (Inside)
-----	-----	-----	-----
13	21.311	43.743	HANDLE 885 ESL2A-APHK @ 0.0°

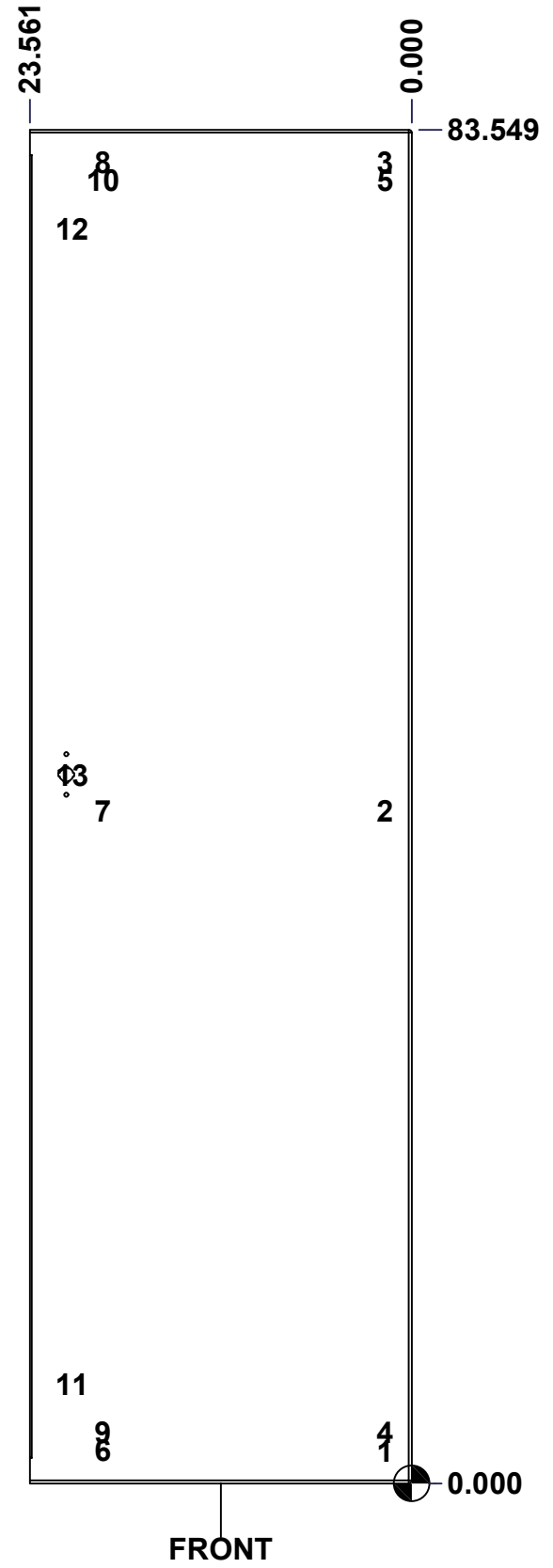

	Description	Status
	9500DD 90" x 48" Lock Door	(NULL)
	Part Number Numéro Pièce	Rev.
	<b>9500DD904820LD</b>	<b>0</b> / 10
		15

This drawing is confidential and must not be reproduced or used without the consent of EXM

Ce dessin est confidentiel et ne doit pas être reproduit ou utilisé sans le consentement de EXM

No.	Revisions	Date	By/Par

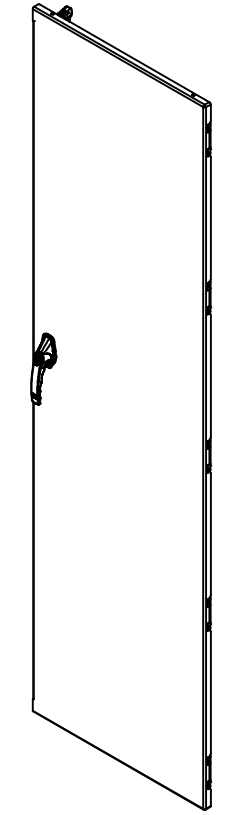

Isometric View



1	STK-Q-47563	0	9500 Lower Closing Bar 90"
1	STK-Q-47553	0	9500 Lower Closing Bar 90"
1	STK-A-50537	3	9500 Handle Cam Assembly (Left Side, Grip 36mm)
1	STK-Q-90051	3	5412 ES - Handle Cam Spacer
1	885ESL2A-APHK	6	885 ESL2A-APHK - Zinc Die Cast L-Handle Padlockable Assy
1	STK-P-02400S	0	Powder Paint (Asa-61 Grey / Smooth)
1	STK-S-00100	0	3.5" x 2" Silver Milar Flexcon Sticker
1	STK-K-10860	3	9500 - Door Stiffener Assembly
2	STK-Q-16410	0	Guide Stud - Largel (No Paint Cap Required)
10	STK-Q-16055	1	M6 x 18mm Stud (No Paint Cap Required)
1	9500DD904820LDG	0	9500DD 90" x 48" Lock Door Gasket
1	9500DD904820LD-P	0	9500DD 90" x 48" Lock Door Part
2	STK-A-90025	0	9500 - Cabinet Closing Bar End (Large)
5	STK-K-09860	7	Cabinet Hinge with Captive Pins
2	STK-Q-07220	1	M6 Nylon Insert Lock Nut

QTY	Part Number	Rev	Description
Parts List			

Tél: (450) 979-4373 Fax: (450) 979-4626 <a href="http://www.exmweb.com">www.exmweb.com</a>	Flatness Aplatissement	Max 3.0mm
	Projection	
Customer Client	Date	
Drawn By Dessiné Par	BoxCad: BoxCad	Date 16-Sep-14
Material Matière	12 Ga Cold Rolled A1008 CS Type B (2.5mm)	
Color Couleur	Asa-61 Grey	Finish Fini Smooth
Description	9500DD 90" x 48" Lock Door	
Part Number Numéro Pièce	Rev. 0	11 / 15
<b>9500DD904820LD</b>		

This drawing is confidential and must not be reproduced or used without the consent of EXM

Ce dessin est confidentiel et ne doit pas être reproduit ou utilisé sans le consentement de EXM



TOP

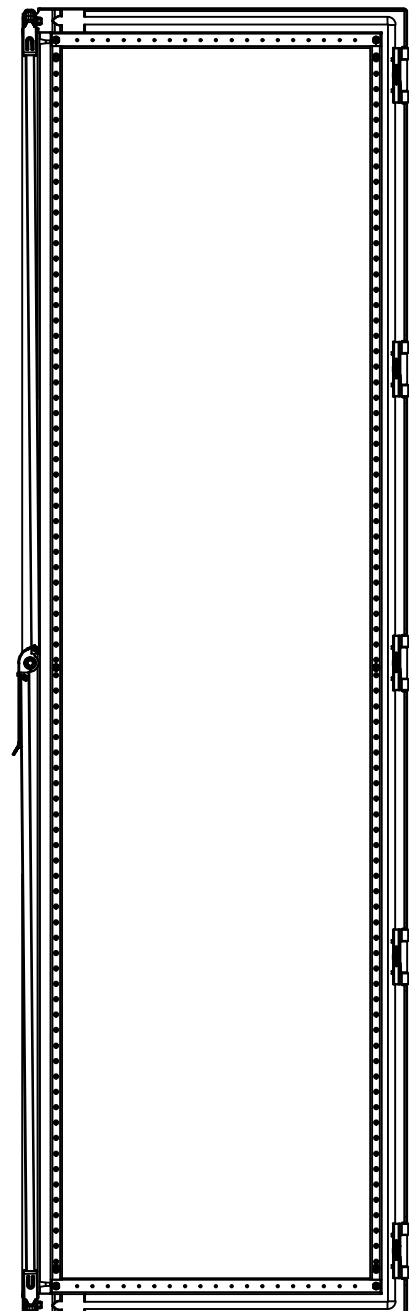

BACK



BOTTOM

0.000  
0.835

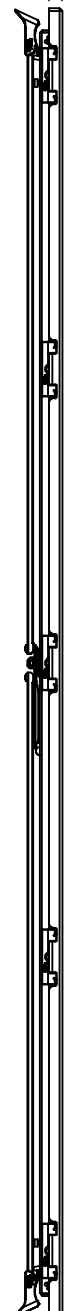

LEFT

0.000  
23.561

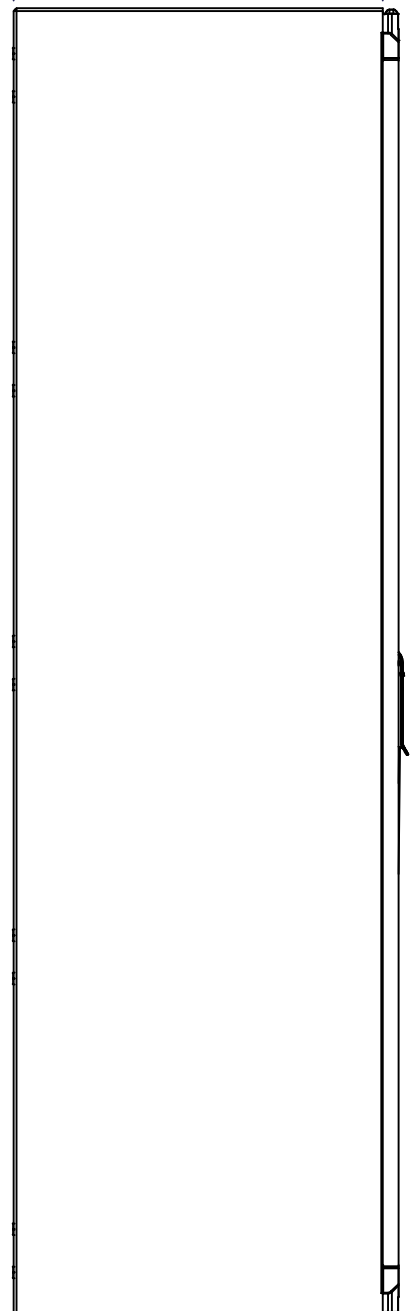

FRONT

83.549

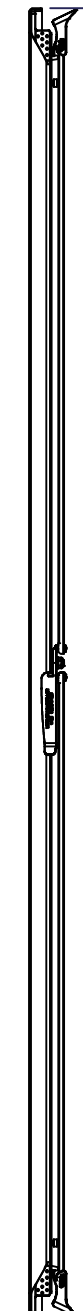

RIGHT

0.000

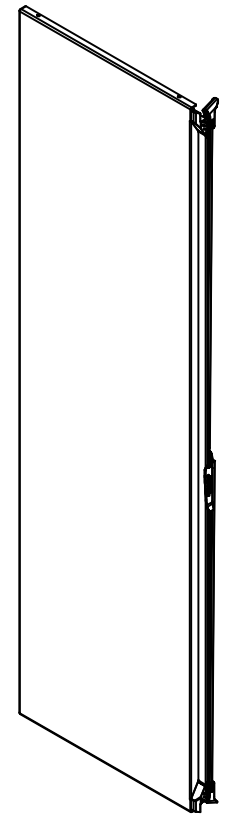

Isometric View

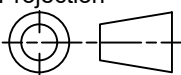

No.	Revisions	Date	By/Par

 Tél: (450) 979-4373 Fax: (450) 979-4626 <a href="http://www.exmweb.com">www.exmweb.com</a>		Flatness Aplatissement Max 3.0mm Projection 
Customer Client	Date	
Drawn By Dessiné Par	BoxCad: BoxCad	Date 16-Sep-14
Material Matière	12 Ga Cold Rolled A1008 CS Type B (2.5mm)	
Color Couleur	Asa-61 Grey	Finish Fini Smooth
Description 9500DD 90" x 48" Flange Door		Detail Rev.
Part Number Numéro Pièce	9500DD904820FD	Rev. 12 0 15

SEE BILL OF MATERIAL ON LAST PAGE

This drawing is confidential and must not be reproduced or used without the consent of EXM

Ce dessin est confidentiel et ne doit pas être reproduit ou utilisé sans le consentement de EXM

**STANDARD FEATURES ARE NOT LISTED IN THIS HOLE TABLE**

**HOLE TABLE - FRONT VIEW (CUSTOM FEATURE ONLY)**

CUT-OUT	XDIM	YDIM	DESCRIPTION
1	2.000	2.028	STUD M6 x 18mm (Inside)
2	2.000	41.486	STUD M6 x 18mm (Inside)
3	2.000	81.521	STUD M6 x 18mm (Inside)
4	2.000	3.139	STUD M6 x 18mm (Inside)
5	2.000	80.409	STUD M6 x 18mm (Inside)
6	22.407	2.028	STUD M6 x 18mm (Inside)
7	22.407	41.486	STUD M6 x 18mm (Inside)
8	22.407	81.521	STUD M6 x 18mm (Inside)
9	22.407	3.139	STUD M6 x 18mm (Inside)
10	22.407	80.409	STUD M6 x 18mm (Inside)
11	24.061	4.774	SMALL CBAR GUIDE (Inside)
12	24.061	78.774	SMALL CBAR GUIDE (Inside)
13	24.061	41.774	STUD M10 x 20mm (Inside)

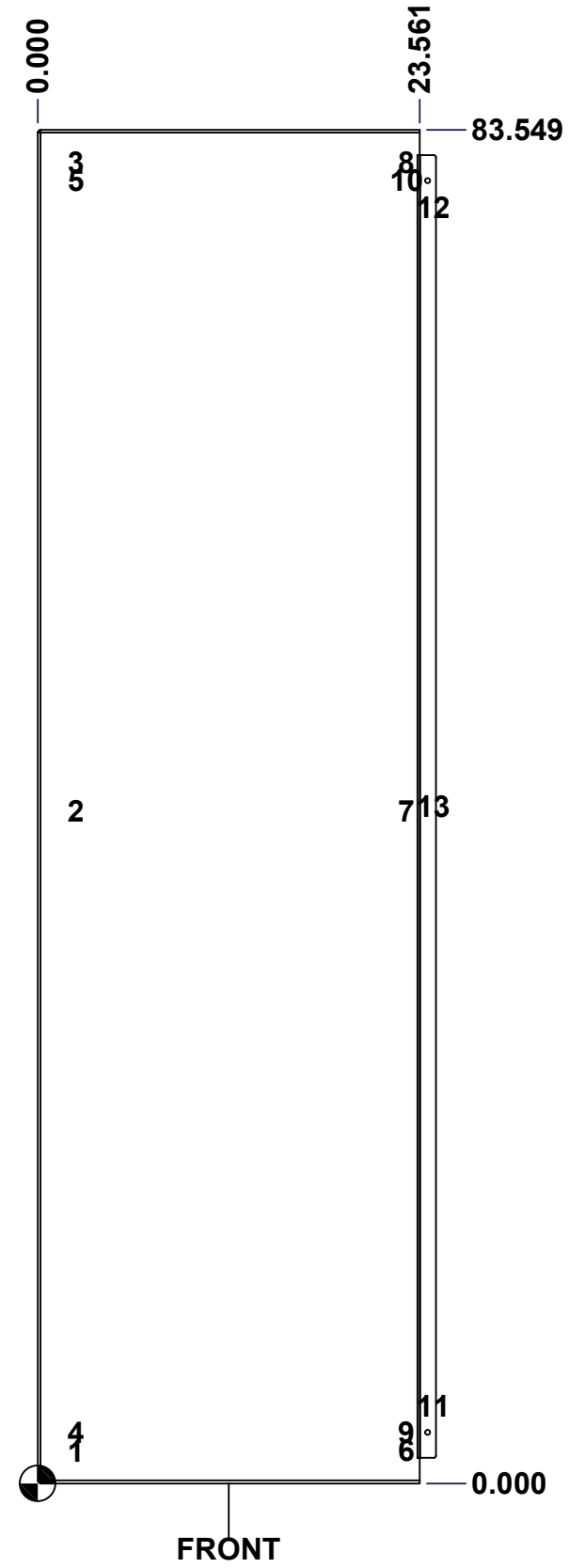

	Description	Status	
	9500DD 90" x 48" Flange Door	(NULL)	
	Part Number	Rev.	13
	Numéro Pièce	<b>0</b>	15
<b>9500DD904820FD</b>			

This drawing is confidential and must not be reproduced or used without the consent of EXM

Ce dessin est confidentiel et ne doit pas être reproduit ou utilisé sans le consentement de EXM

No.	Revisions	Date	By/Par

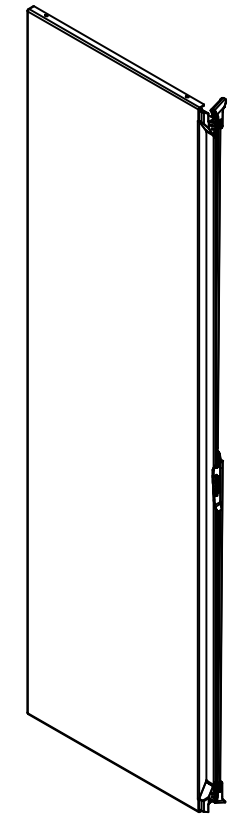

Isometric View



1	STK-P-02400S	0	Powder Paint (Asa-61 Grey / Smooth)
1	STK-G-03400	1	5500 DD Lower Flange Door Gasket
1	STK-G-03300	2	5500 DD Upper Flange Door Gasket
2	STK-Q-90045	0	Cabinet - Closing Bar End
2	STK-Q-45660-90	2	9500 DD - Flange Door Closing Bar
1	STK-K-50556	4	9500 DD - Flange Door Handle Assy
1	STK-K-20860	3	9500 - Flange Door Stiffener Assembly
1	STK-Q-16122	2	Stud M10 x 20mm
2	STK-Q-16405	7	Guide Stud - Small (No Paint Cap Required)
10	STK-Q-16055	1	M6 x 18mm Stud (No Paint Cap Required)
1	STK-G-00701	0	1" x 1/4" Self-Adhesive Neoprene Gasket
1	9500DD904820FDG	0	9500DD 90" x 48" Flange Door Gasket
1	9500DD904820FD-P	0	9500DD 90" x 48" Flange Door Part
5	STK-K-09860	7	Cabinet Hinge with Captive Pins

QTY	Part Number	Rev	Description
Parts List			

	Flatness Aplatissement Max 3.0mm
	Projection 
Customer Client	Date
Drawn By Dessiné Par BoxCad: BoxCad	Date 16-Sep-14
Material Matière 12 Ga Cold Rolled A1008 CS Type B (2.5mm)	
Color Couleur Asa-61 Grey	Finish Fini Smooth
Description 9500DD 90" x 48" Flange Door	
Detail Rev.	
Part Number Numéro Pièce <b>9500DD904820FD</b>	Rev. 14 <b>0</b> 15

All knockouts are actual size / Les disques défonçables sont grandeur réel  
 All dimensions are before paint / Toutes les dimensions sont avant peinture

This drawing is confidential and must not be reproduced or used without the consent of EXM

Ce dessin est confidentiel et ne doit pas être reproduit ou utilisé sans le consentement de EXM

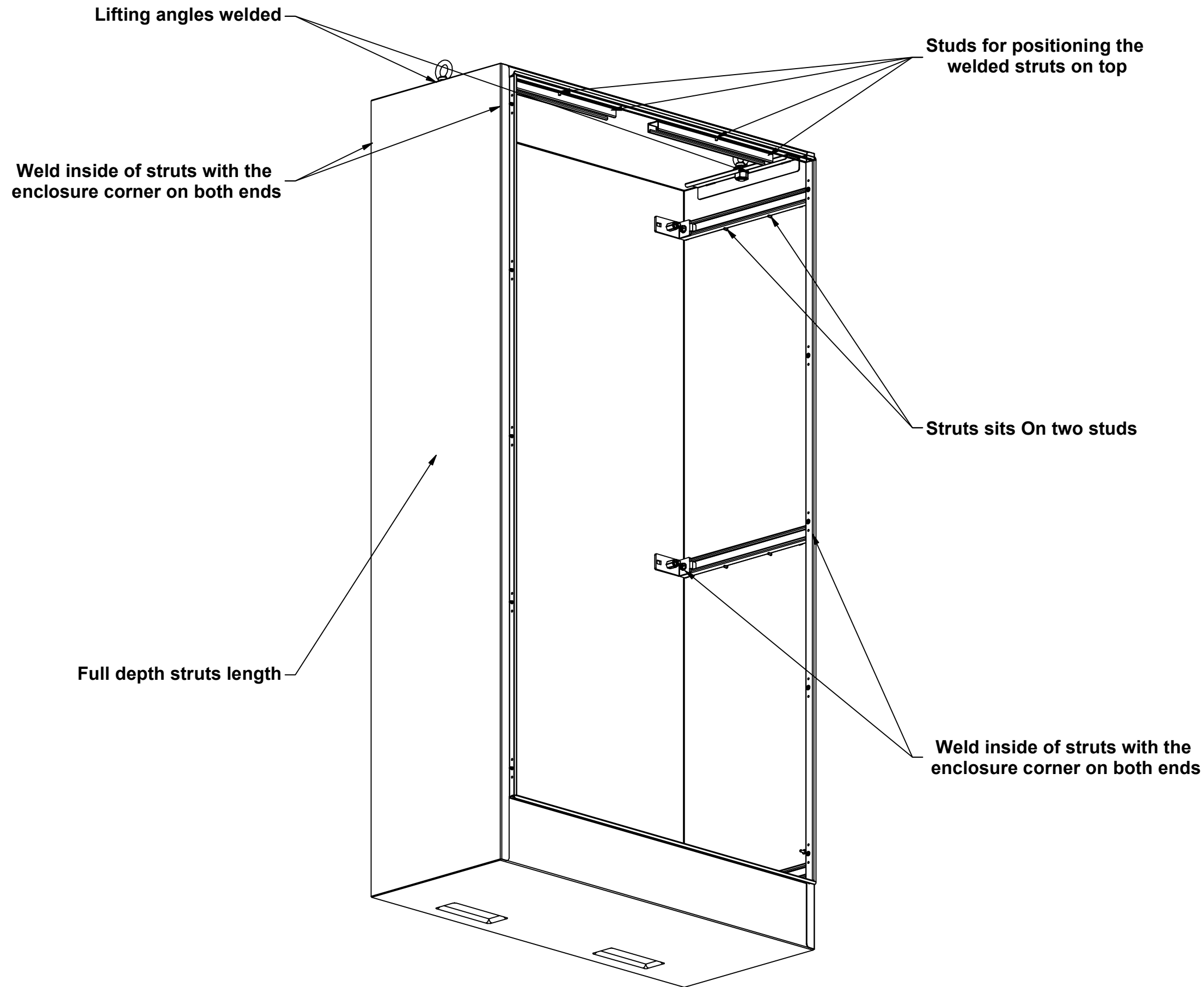

No.	Revisions	Date	By/Par

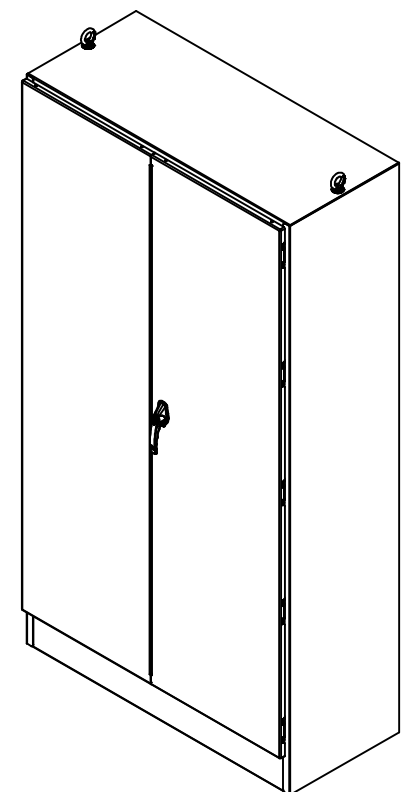

Isometric View



Tél: (450) 979-4373  
 Fax: (450) 979-4626  
[www.exmweb.com](http://www.exmweb.com)

Flatness  
 Aplatissement  
 Max 3.0mm  
 Projection

Customer Client	Date
Drawn By Dessiné Par BoxCad	Date 11-Aug-05
Material Matière 12 Ga Cold Rolled A1008 CS Type B (2.5mm)	
Color Couleur Asa-61 Grey	Finish Fini Smooth
Description 9500DD 90" x 48" x 20" Assembly	Detail Rev.
Part Number Numéro Pièce 9500DD Welding Details	Rev. 15 <b>0</b> 15