

This drawing is confidential and must not be reproduced or used without the consent of EXM

Ce dessin est confidentiel et ne doit pas être reproduit ou utilisé sans le consentement de EXM

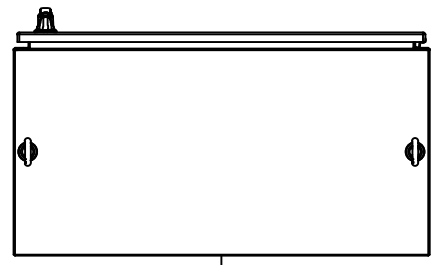

TOP

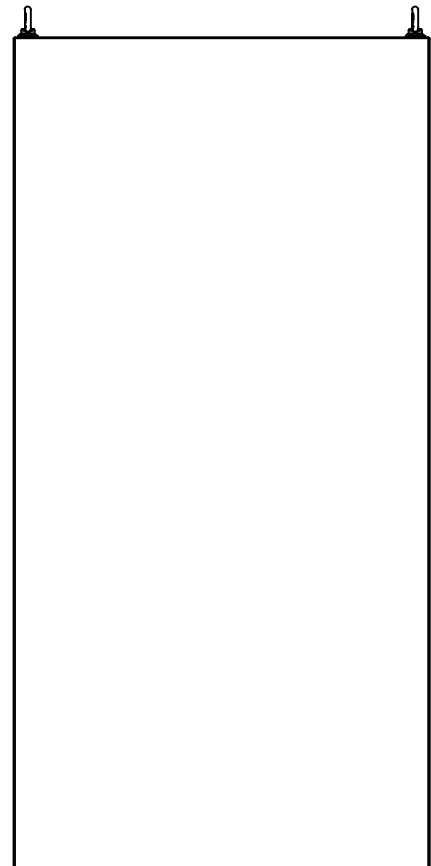

BACK

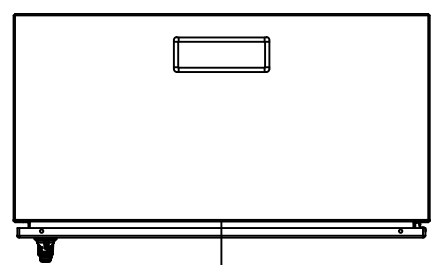

BOTTOM

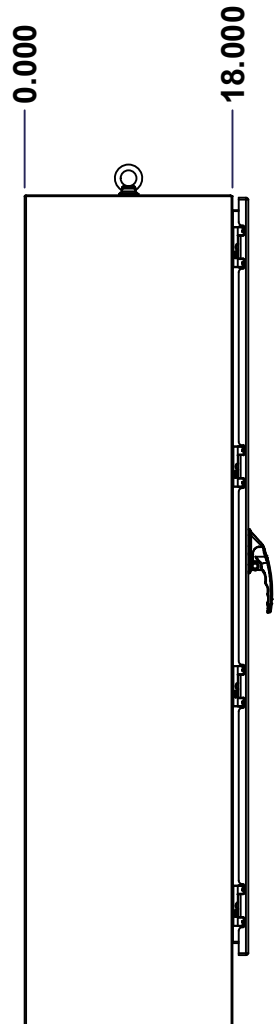

LEFT

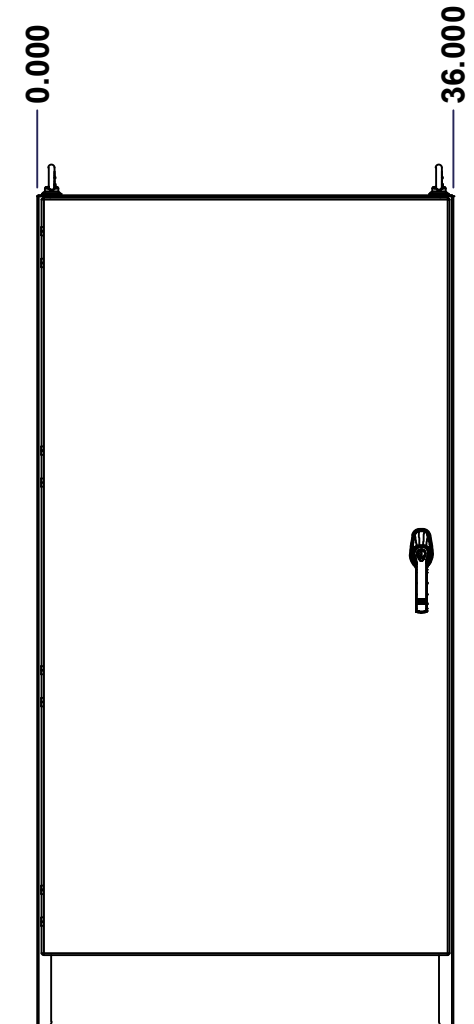

FRONT

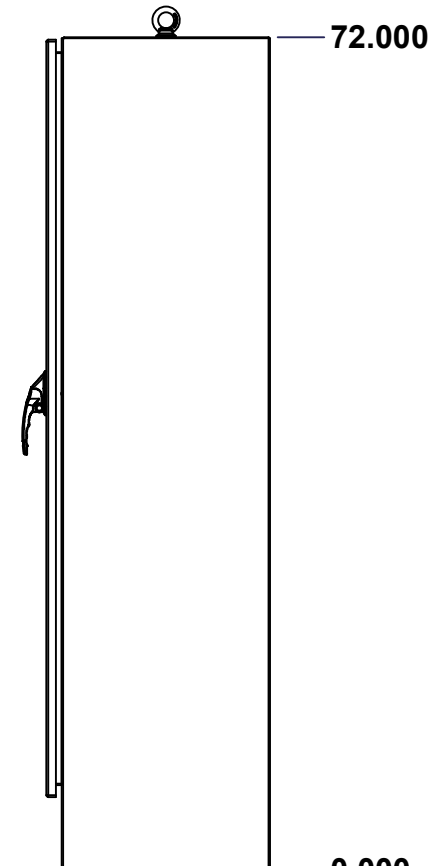

RIGHT

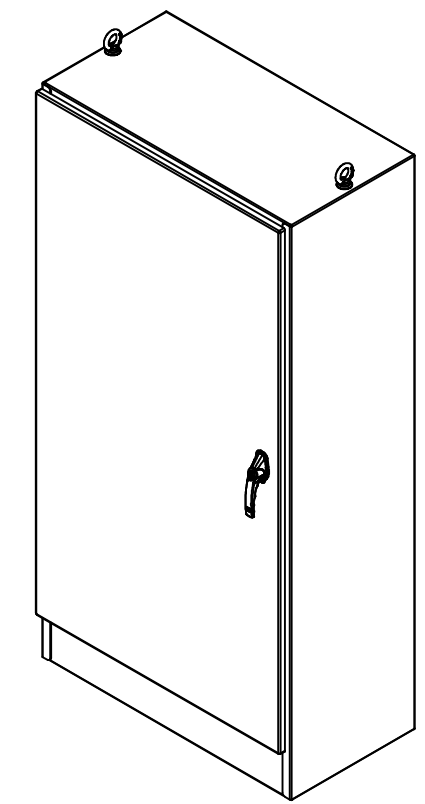

Isometric View

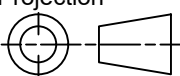

| No. | Revisions | Date | By/Par |
|-----|-----------|------|--------|
| | | | |
| | | | |
| | | | |
| | | | |
| | | | |

| | | |
|--|---|---|
|  Tél: (450) 979-4373 Fax: (450) 979-4626 www.exmweb.com | | Flatness Aplatissement Max 3.0mm Projection  |
| Customer Client | Date | |
| Drawn By Dessiné Par | BoxCad: BoxCad | Date 09-Dec-21 |
| Material Matière | 12 Ga Cold Rolled A1008 CS Type B (2.5mm) | |
| Color Couleur | Asa-61 Grey | Finish Fini Smooth |
| Description | Detail Rev. | |
| 9500 72" x 36" x 18" Assembly | | |
| Part Number Numéro Pièce | Rev. | 1 |
| 9500ST723618 | 0 | 11 |

SEE BILL OF MATERIAL ON LAST PAGE

This drawing is confidential and must not be reproduced or used without the consent of EXM

Ce dessin est confidentiel et ne doit pas être reproduit ou utilisé sans le consentement de EXM

| NOTE | |
|------|---|
| ITEM | DESCRIPTION |
| 1 | NEMA 12, 13 Enclosure (IP55) |
| 2 | C/W Standard ground studs on box and cover |
| 3 | C/W Standard door stiffener |
| 4 | W/O Inner panel |
| 5 | C/W Standard inner panel mounting studs |
| 6 | C/W Eyebolts sold separately (Installed by EXM) |
| 7 | C/W Struts installed (Included) |

| No. | Revisions | Date | By/Par |
|-----|-----------|------|--------|
| | | | |
| | | | |
| | | | |
| | | | |
| | | | |
| | | | |

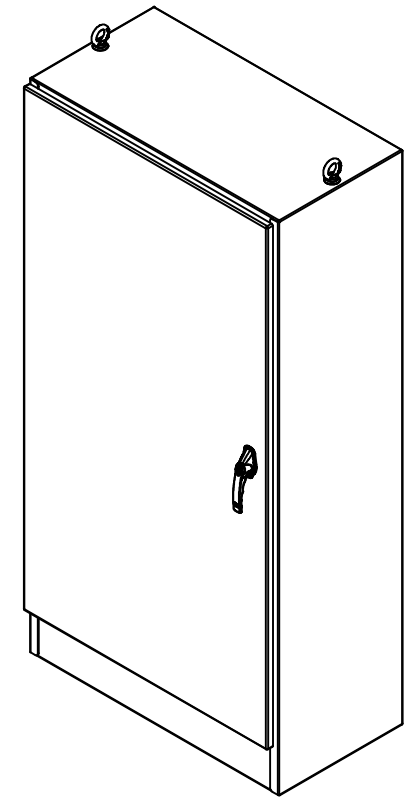

Isometric View

| PACKING | | |
|-----------------------|-----|--|
| ITEM | QTY | DESCRIPTION |
| Cardboard sleeve | 2 | Top and Bottom |
| Cardboard strip | 2 | Between back of enclosure and inner panel |
| Plastic bag | 1 | To protect cover surface and inside gasket |
| Cardboard corner | 4 | To reinforced for the plastic strap tightening |
| Plastic strap - Black | 2 | To Squeeze 2 cardboard sleeve together |
| Packaging label | 3 | White label with PN |
| Plastic strap- Green | 2 | To secure the enclosure to the wood pallet |
| Wood Pallet | 1 | 2" deeper and 3" larger than enclosure size |

| Qty | Part Number | Rev | Description |
|------------|----------------|-----|---|
| 1 | 9500ST723618GP | 0 | 9500 Gland Plate |
| 1 | 880EB14 | 2 | Eye Bolt M14 (Pack of 2) |
| 1 | 9500ST723618C | 0 | 9500 72" x 36" Cover |
| 1 | 9500ST723618B | 0 | 9500 72" x 36" x 18" Body |
| 4 | STK-Q-04050-10 | 8 | M6 x 10mm Hexagon Socket Head Machine Screw with Nyseal |
| Parts List | | | |

| | | |
|--|--|--|
| | Tél: (450) 979-4373 Fax: (450) 979-4626 www.exmweb.com | Flatness Aplatissement Max 3.0mm |
| | Projection | Customer Client Date |
| Drawn By Dessiné Par BoxCad: BoxCad | Date 09-Dec-21 | Material Matière 12 Ga Cold Rolled A1008 CS Type B (2.5mm) |
| Color Couleur Asa-61 Grey | Finish Fini Smooth | Description 9500 72" x 36" x 18" Assembly |
| Part Number Numéro Pièce 9500ST723618 | Rev. 0 | Detail Rev. 2 11 |

This drawing is confidential and must not be reproduced or used without the consent of EXM

Ce dessin est confidentiel et ne doit pas être reproduit ou utilisé sans le consentement de EXM

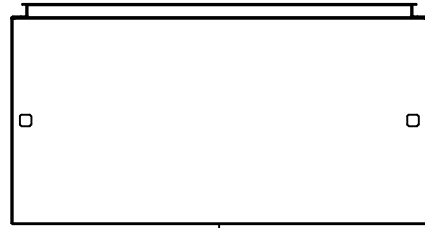

TOP



BACK

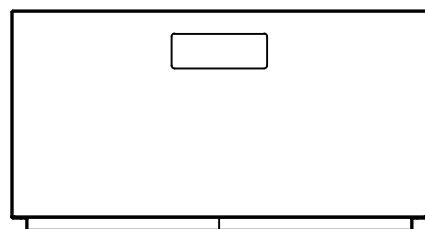

BOTTOM

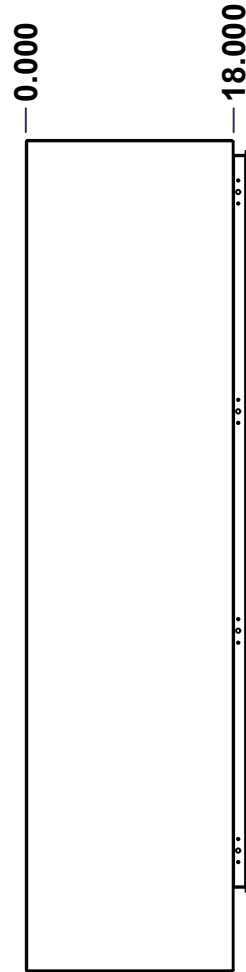

LEFT

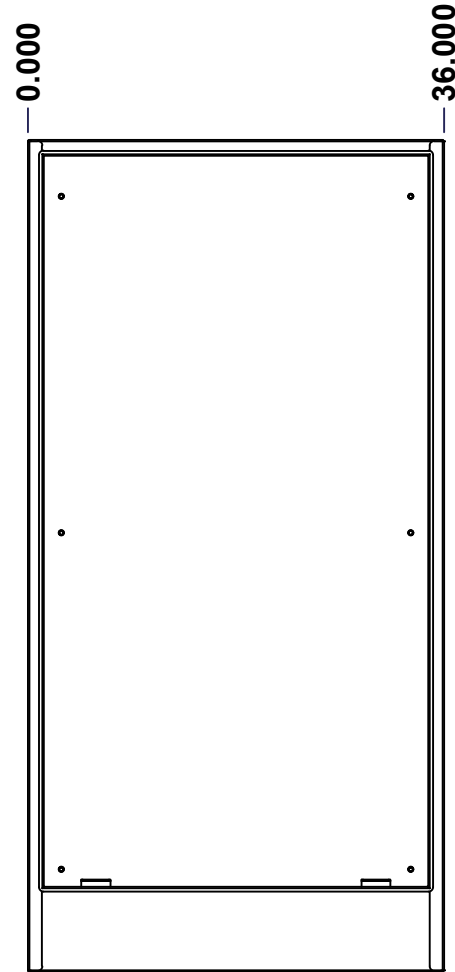

FRONT

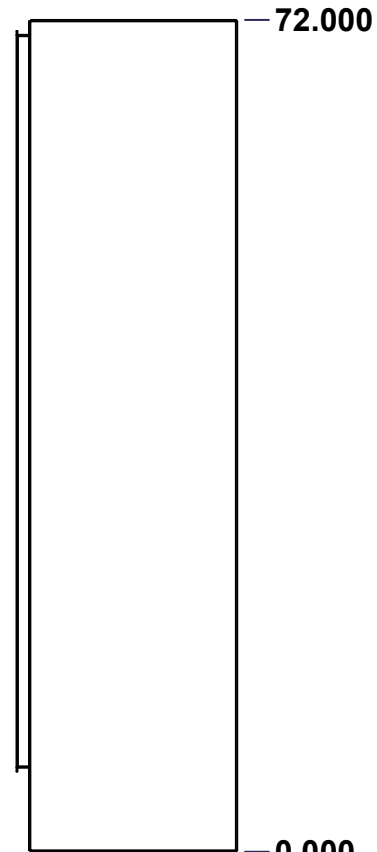

RIGHT

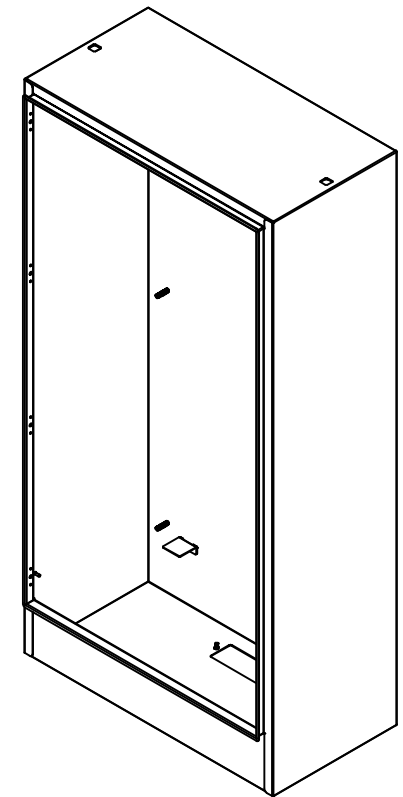

Isometric View

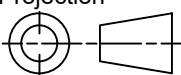

| No. | Revisions | Date | By/Par |
|-----|-----------|------|--------|
| | | | |
| | | | |
| | | | |
| | | | |

| | | |
|--|---|---|
|  Tél: (450) 979-4373 Fax: (450) 979-4626 www.exmweb.com | | Flatness Aplatissement Max 3.0mm Projection  |
| Customer Client | Date | |
| Drawn By Dessiné Par | BoxCad: BoxCad | Date 09-Dec-21 |
| Material Matière | 12 Ga Cold Rolled A1008 CS Type B (2.5mm) | |
| Color Couleur | Asa-61 Grey | Finish Fini Smooth |
| Description | Detail Rev. | |
| 9500 72" x 36" x 18" Body | | |
| Part Number Numéro Pièce | Rev. 0 | 3 / 11 |
| 9500ST723618B | | |

SEE BILL OF MATERIAL ON LAST PAGE

This drawing is confidential and must not be reproduced or used without the consent of EXM

Ce dessin est confidentiel et ne doit pas être reproduit ou utilisé sans le consentement de EXM

| STANDARD FEATURES ARE NOT LISTED IN THIS HOLE TABLE | | | |
|---|--------|--------|-------------------------------|
| HOLE TABLE - TOP VIEW (CUSTOM FEATURE ONLY) | | | |
| CUT-OUT | XDIM | YDIM | DESCRIPTION |
| 1 | 18.000 | 14.000 | Struts CR400 27.500" (Inside) |
| 2 | 18.000 | 14.929 | STUDS M6 x 10mm (Inside) |
| 3 | 31.866 | 14.000 | STUDS M6 x 10mm (Inside) |

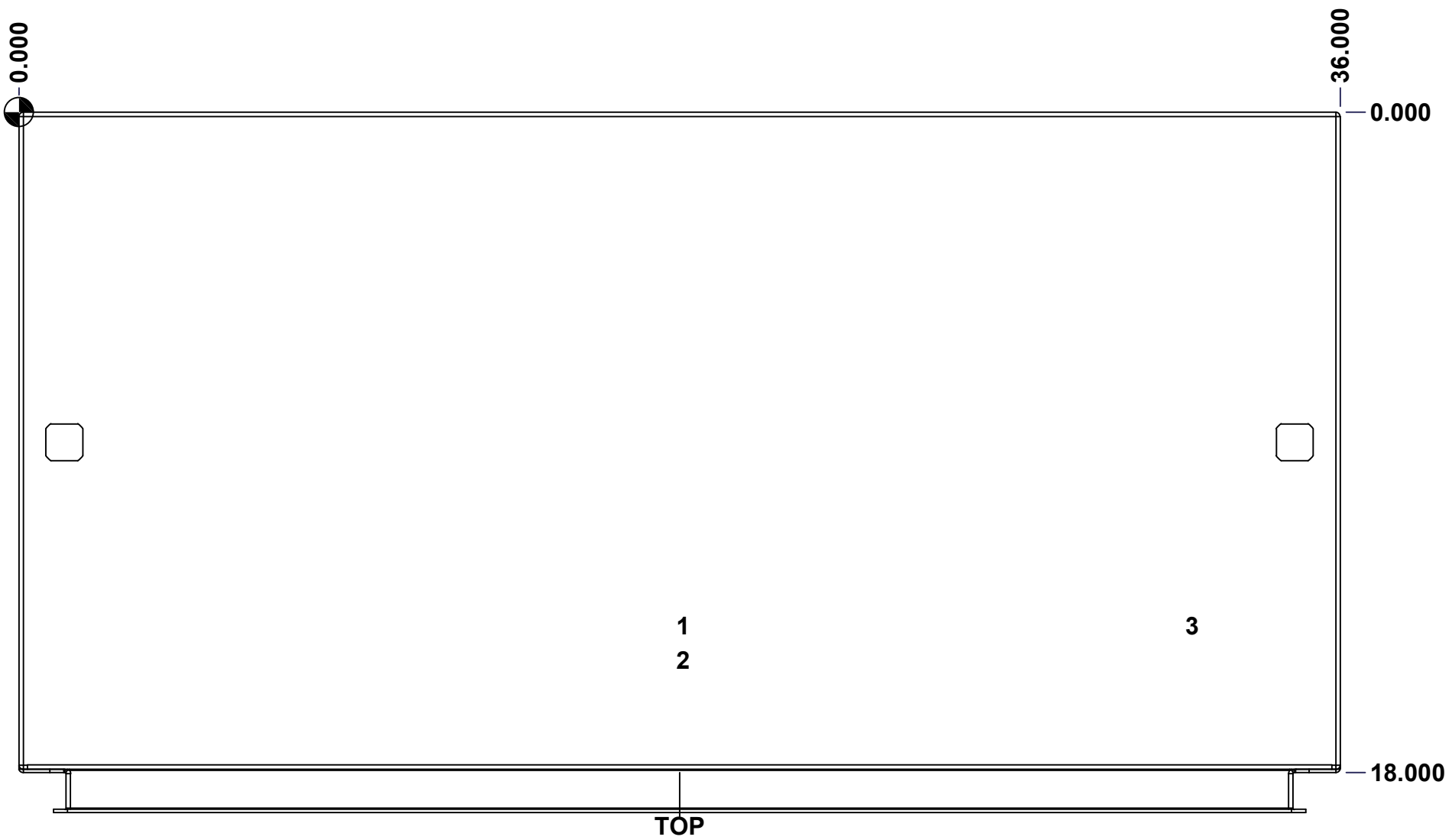

| | | |
|--|---|--------------------|
| | Description 9500 72" x 36" x 18" Body | Status (NULL) |
| | Part Number Numéro Pièce 9500ST723618B | Rev. 4 0 |

This drawing is confidential and must not be reproduced or used without the consent of EXM

Ce dessin est confidentiel et ne doit pas être reproduit ou utilisé sans le consentement de EXM

| STANDARD FEATURES ARE NOT LISTED IN THIS HOLE TABLE | | | |
|--|--------|-------|----------------------------|
| HOLE TABLE - BOTTOM VIEW (CUSTOM FEATURE ONLY) | | | |
| CUT-OUT | XDIM | YDIM | DESCRIPTION |
| 1 | 13.375 | 3.500 | GP STUD M6 x 16mm (Inside) |
| 2 | 22.625 | 3.500 | GP STUD M6 x 16mm (Inside) |

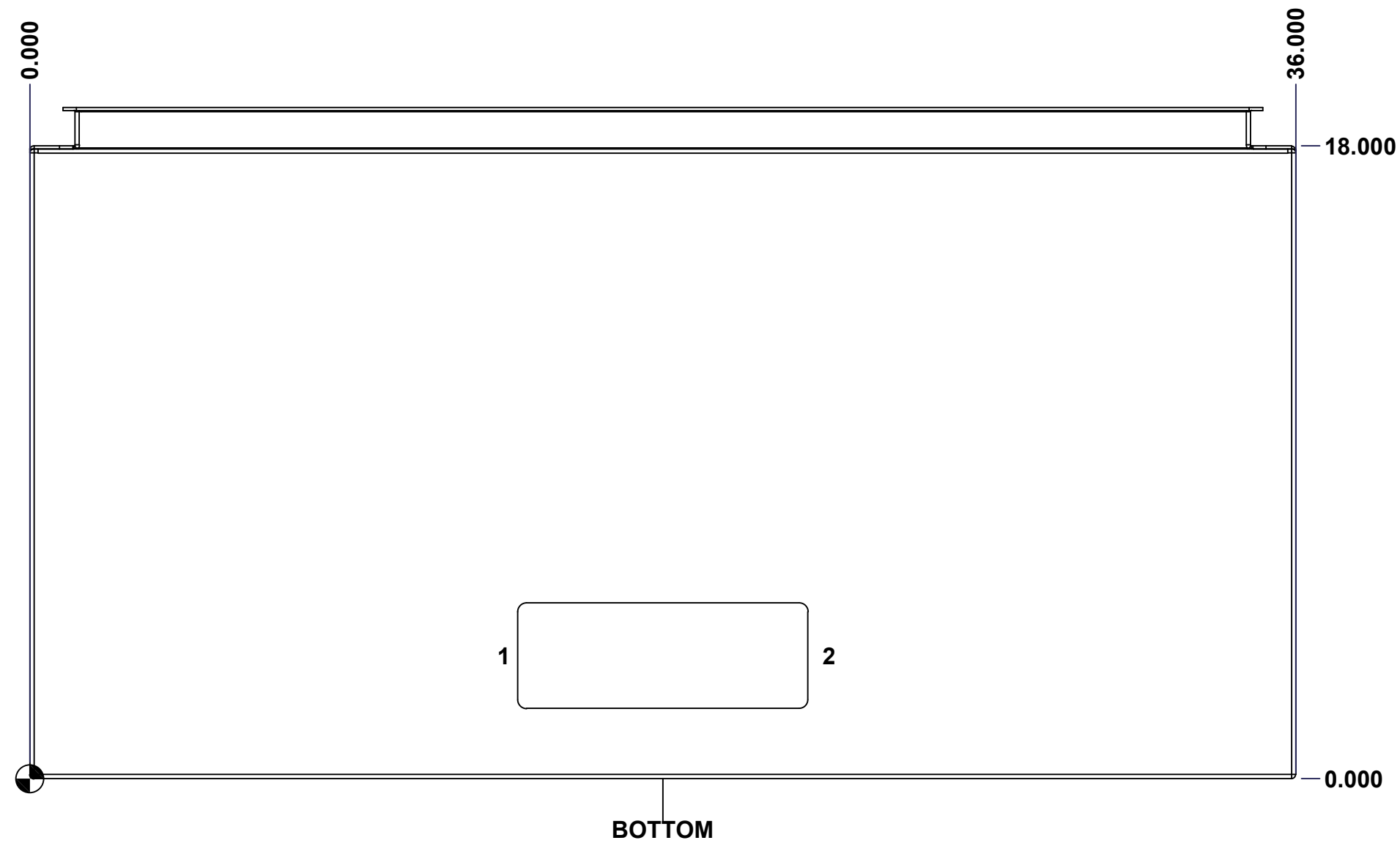

| | | |
|--|---|-------------------------|
| | Description 9500 72" x 36" x 18" Body | Status (NULL) |
| | Part Number Numéro Pièce 9500ST723618B | Rev. 5 0 / 11 |

This drawing is confidential and must not be reproduced or used without the consent of EXM

Ce dessin est confidentiel et ne doit pas être reproduit ou utilisé sans le consentement de EXM

| STANDARD FEATURES ARE NOT LISTED IN THIS HOLE TABLE | | | |
|--|--------|-------|-----------------------------|
| HOLE TABLE - LEFT VIEW (CUSTOM FEATURE ONLY) | | | |
| CUT-OUT | XDIM | YDIM | DESCRIPTION |
| 1 | 16.500 | 9.375 | GND STUD M6 x 16mm (Inside) |

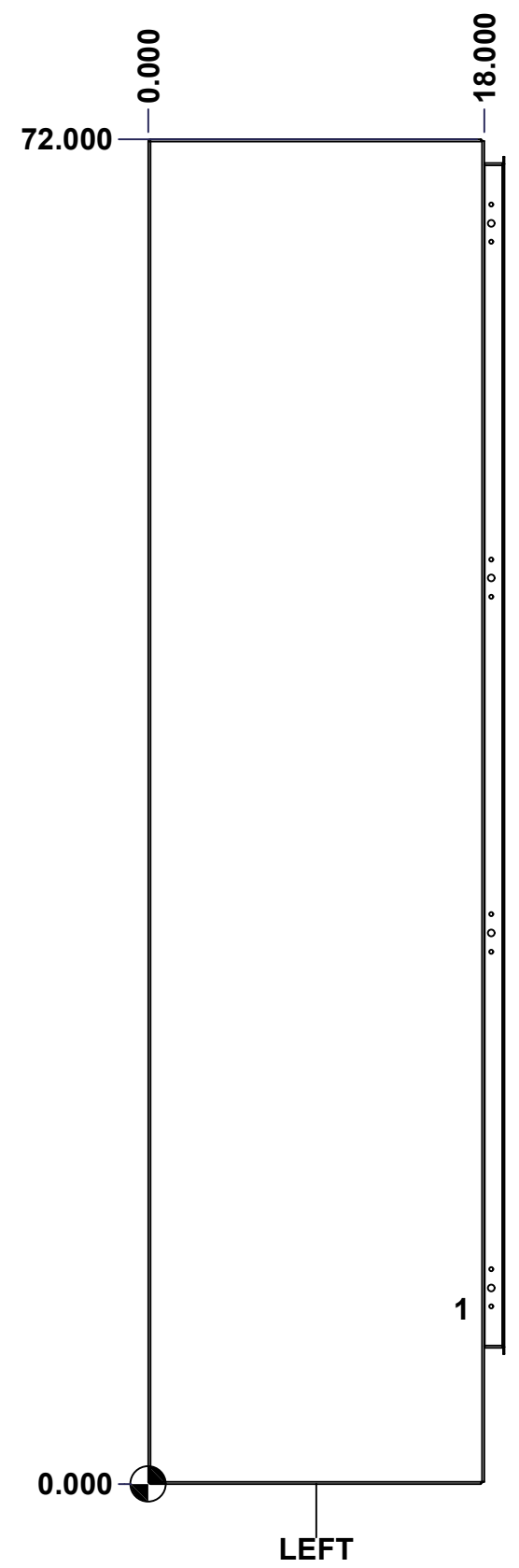

| | | | |
|--|-----------------------------|----------|---------|
| | Description | Status | |
| | 9500 72" x 36" x 18" Body | (NULL) | |
| | Part Number Numéro Pièce | Rev. | |
| | 9500ST723618B | 0 | 6 11 |

This drawing is confidential and must not be reproduced or used without the consent of EXM

Ce dessin est confidentiel et ne doit pas être reproduit ou utilisé sans le consentement de EXM

STANDARD FEATURES ARE NOT LISTED IN THIS HOLE TABLE

HOLE TABLE - BACK VIEW (CUSTOM FEATURE ONLY)

| CUT-OUT | XDIM | YDIM | DESCRIPTION |
|---------|--------|--------|-----------------------------|
| 1 | 2.875 | 8.875 | IP STUD M10 x 40mm (Inside) |
| 2 | 33.125 | 8.875 | IP STUD M10 x 40mm (Inside) |
| 3 | 2.875 | 38.000 | IP STUD M10 x 40mm (Inside) |
| 4 | 33.125 | 38.000 | IP STUD M10 x 40mm (Inside) |
| 5 | 2.875 | 67.125 | IP STUD M10 x 40mm (Inside) |
| 6 | 33.125 | 67.125 | IP STUD M10 x 40mm (Inside) |
| ----- | ----- | ----- | ----- |
| 7 | 30.125 | 7.500 | IP SUPPORT ANGLE (Inside) |
| 8 | 5.875 | 7.500 | IP SUPPORT ANGLE (Inside) |

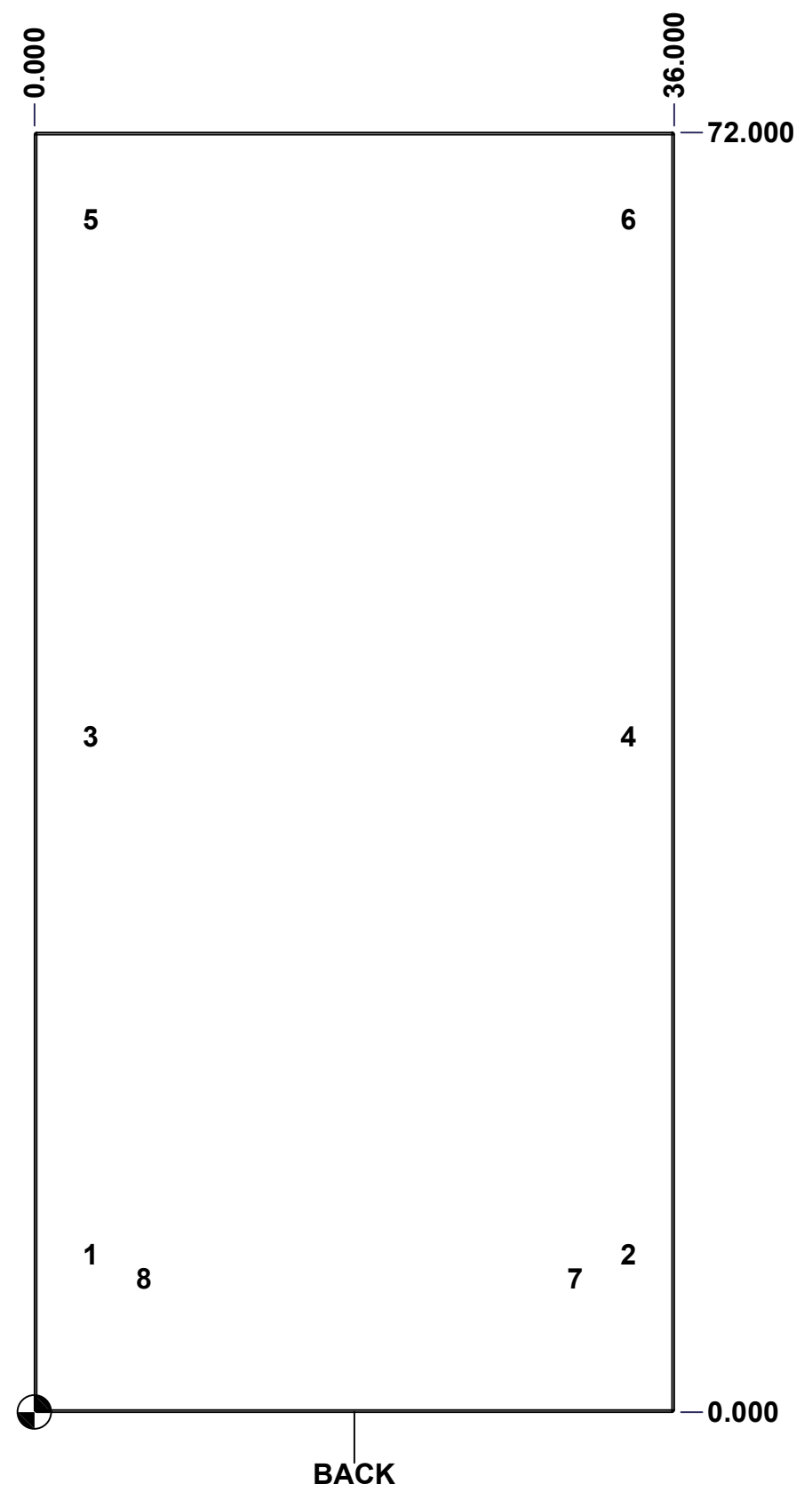

| | | |
|--|---|--------------------|
| | Description 9500 72" x 36" x 18" Body | Status (NULL) |
| | Part Number Numéro Pièce 9500ST723618B | Rev. 7 0 |

This drawing is confidential and must not be reproduced or used without the consent of EXM

Ce dessin est confidentiel et ne doit pas être reproduit ou utilisé sans le consentement de EXM

| No. | Revisions | Date | By/Par |
|-----|-----------|------|--------|
| | | | |
| | | | |
| | | | |
| | | | |
| | | | |

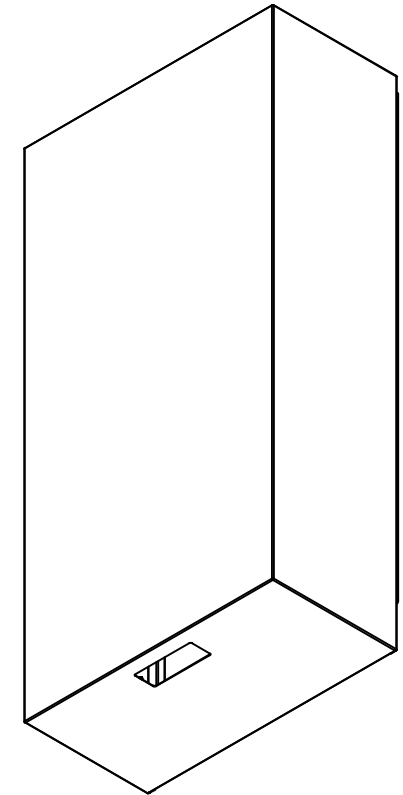

Isometric View

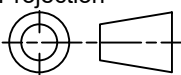

| | | |
|--|---|---|
|  Tél: (450) 979-4373 Fax: (450) 979-4626 www.exmweb.com | | Flatness Aplatissement Max 3.0mm Projection  |
| Customer Client | Date | |
| Drawn By Dessiné Par | BoxCad: BoxCad | Date 09-Dec-21 |
| Material Matière | 12 Ga Cold Rolled A1008 CS Type B (2.5mm) | |
| Color Couleur | Asa-61 Grey | Finish Fini Smooth |
| Description | | Detail Rev. |
| 9500 72" x 36" x 18" Body | | |
| Part Number Numéro Pièce | Rev. | 8 |
| 9500ST723618B | 0 | 11 |

| Qty | Part Number | Rev | Description |
|------------|---------------------------|-----|--|
| 2 | STK-Q-16030 | 0 | Stud M6 x 10mm Steel |
| 2 | 9500ST723618BPA-P | 0 | 9500 Inner Panel Support Angle |
| 1 | 9500ST723618_CR400MS_27.5 | 0 | Commercial Roll Mild Steel (27.5in long) |
| 1 | STK-P-02400S | 0 | Powder Paint (Asa-61 Grey / Smooth) |
| 2 | STK-Q-74900 | 0 | Eyebolt Lifting Angle (8.750") |
| 6 | STK-Q-16100 | 0 | Stud M10 x 40mm Steel |
| 1 | 9500ST723618B-P | 0 | 9500 72" x 36" Body Part |
| 3 | STK-Q-16080 | 0 | Ground Stud M6 x 16mm Steel |
| Parts List | | | |

This drawing is confidential and must not be reproduced or used without the consent of EXM

Ce dessin est confidentiel et ne doit pas être reproduit ou utilisé sans le consentement de EXM

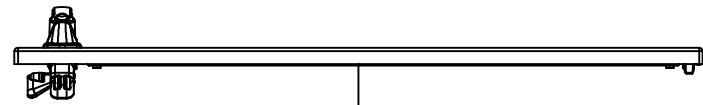

TOP

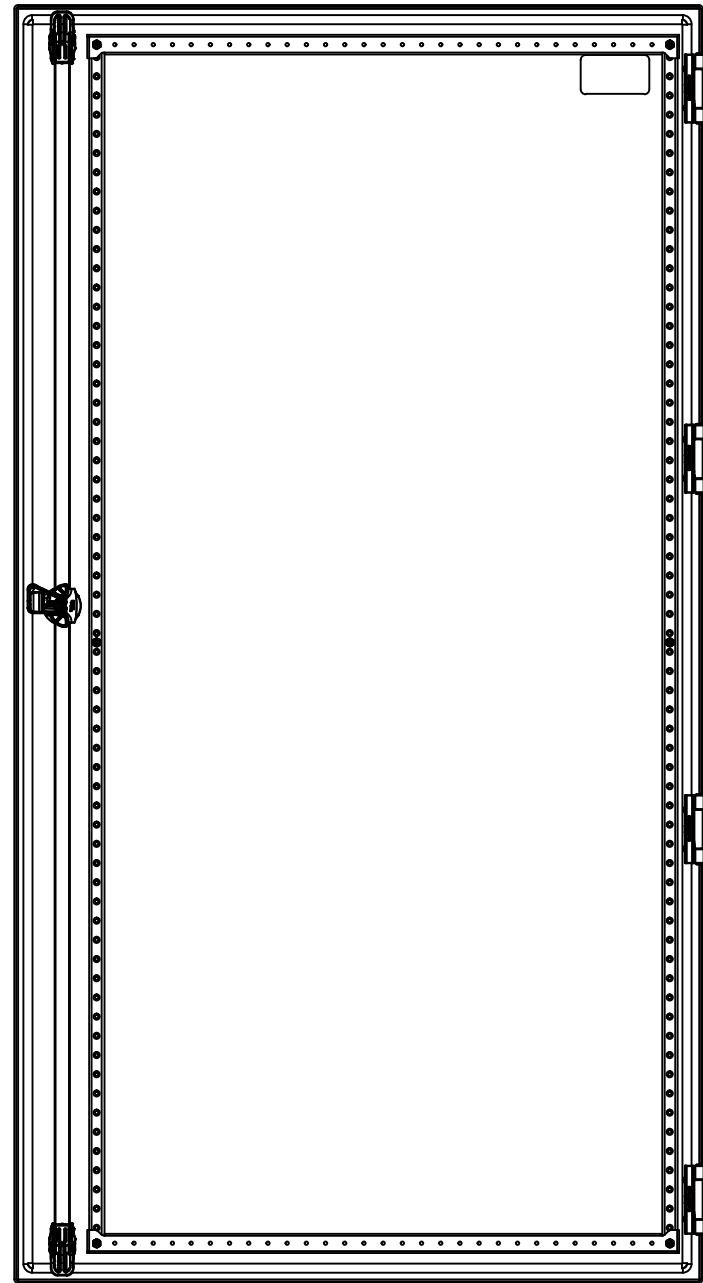

BACK



BOTTOM

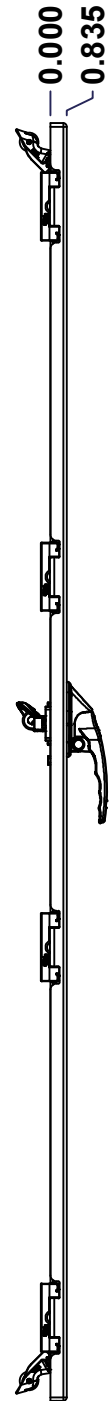

LEFT

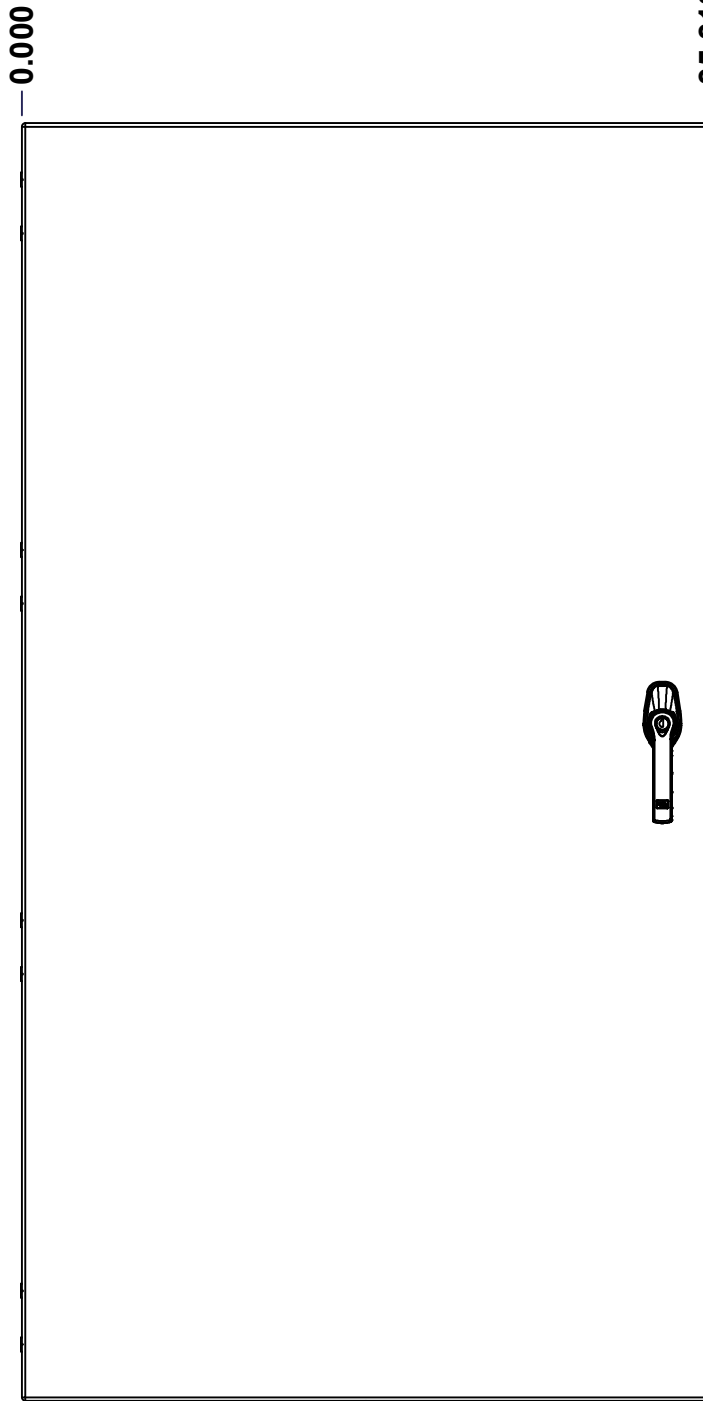

FRONT

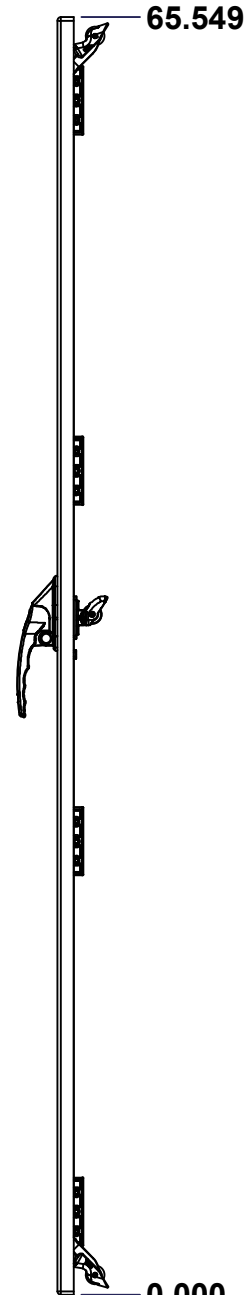

RIGHT

0.000
0.835

0.000

35.312

65.549

0.000

| No. | Revisions | Date | By/Par |
|-----|-----------|------|--------|
| | | | |
| | | | |
| | | | |
| | | | |
| | | | |

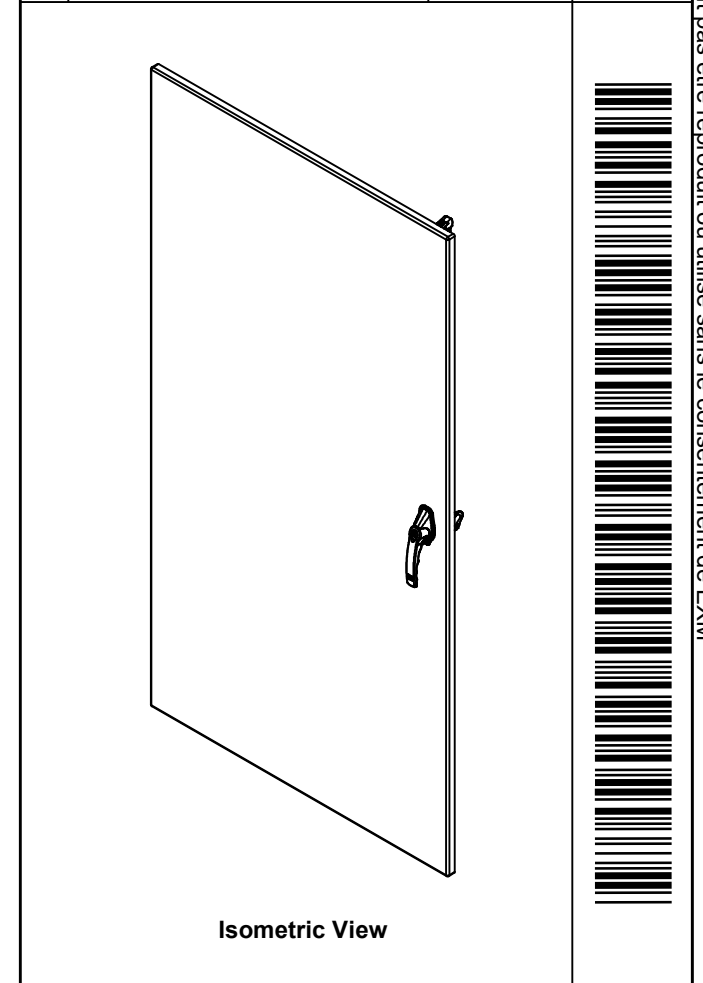

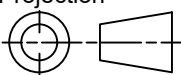
| | | |
|--|---|---------------------------|
|  Tél: (450) 979-4373 Fax: (450) 979-4626 www.exmweb.com | | Flatness Aplatissement |
| | | Max 3.0mm |
| Projection  | | Date |
| Customer Client | BoxCad: BoxCad | Date |
| Drawn By Dessiné Par | BoxCad: BoxCad | 09-Dec-21 |
| Material Matière | 12 Ga Cold Rolled A1008 CS Type B (2.5mm) | |
| Color Couleur | Asa-61 Grey | Finish Fini: Smooth |
| Description | 9500 72" x 36" Cover | |
| Part Number Numéro Pièce | 9500ST723618C | Detail Rev. |
| Rev. | 0 | 9 |
| | | 11 |

SEE BILL OF MATERIAL ON LAST PAGE

This drawing is confidential and must not be reproduced or used without the consent of EXM

Ce dessin est confidentiel et ne doit pas être reproduit ou utilisé sans le consentement de EXM

| STANDARD FEATURES ARE NOT LISTED IN THIS HOLE TABLE | | | |
|---|--------|--------|------------------------------|
| HOLE TABLE - FRONT VIEW (CUSTOM FEATURE ONLY) | | | |
| CUT-OUT | XDIM | YDIM | DESCRIPTION |
| 1 | 1.685 | 2.028 | STUD M6 x 18mm (Inside) |
| 2 | 1.685 | 32.854 | STUD M6 x 18mm (Inside) |
| 3 | 1.685 | 63.521 | STUD M6 x 18mm (Inside) |
| 4 | 31.092 | 2.028 | STUD M6 x 18mm (Inside) |
| 5 | 31.092 | 32.854 | STUD M6 x 18mm (Inside) |
| 6 | 31.092 | 63.521 | STUD M6 x 18mm (Inside) |
| 7 | 32.858 | 6.118 | LARGE CBAR GUIDE (Inside) |
| 8 | 32.858 | 59.430 | LARGE CBAR GUIDE (Inside) |
| ----- | ----- | ----- | ----- |
| 9 | 32.858 | 34.743 | HANDLE 885 ESL2A-APHK @ 0.0° |

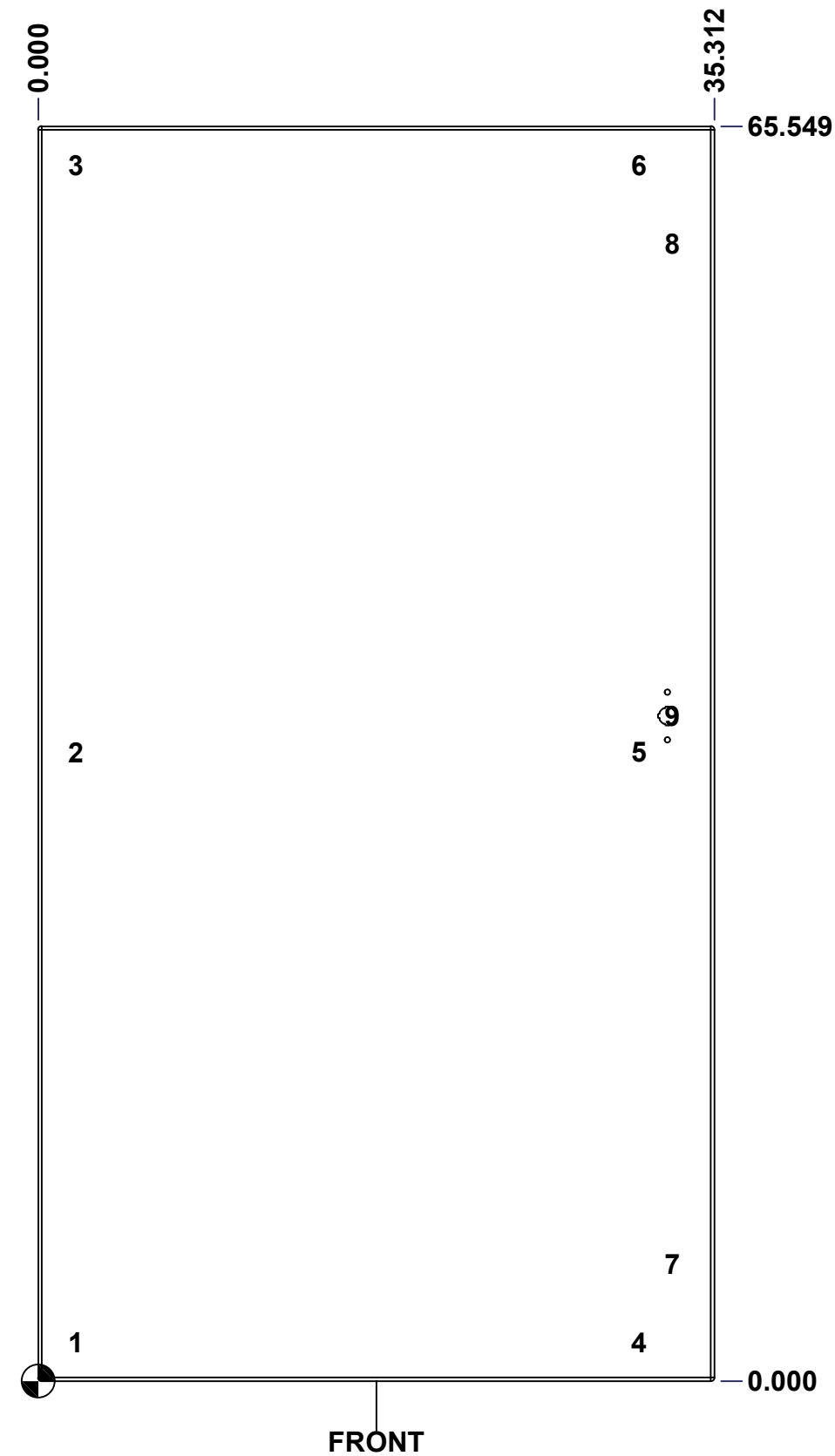

FRONT

| | | |
|--|-----------------------------|--------------------|
| | Description | Status |
| | 9500 72" x 36" Cover | (NULL) |
| | Part Number Numéro Pièce | Rev. |
| | 9500ST723618C | 0 / 10 / 11 |

This drawing is confidential and must not be reproduced or used without the consent of EXM

Ce dessin est confidentiel et ne doit pas être reproduit ou utilisé sans le consentement de EXM

| No. | Revisions | Date | By/Par |
|-----|-----------|------|--------|
| | | | |
| | | | |
| | | | |
| | | | |
| | | | |

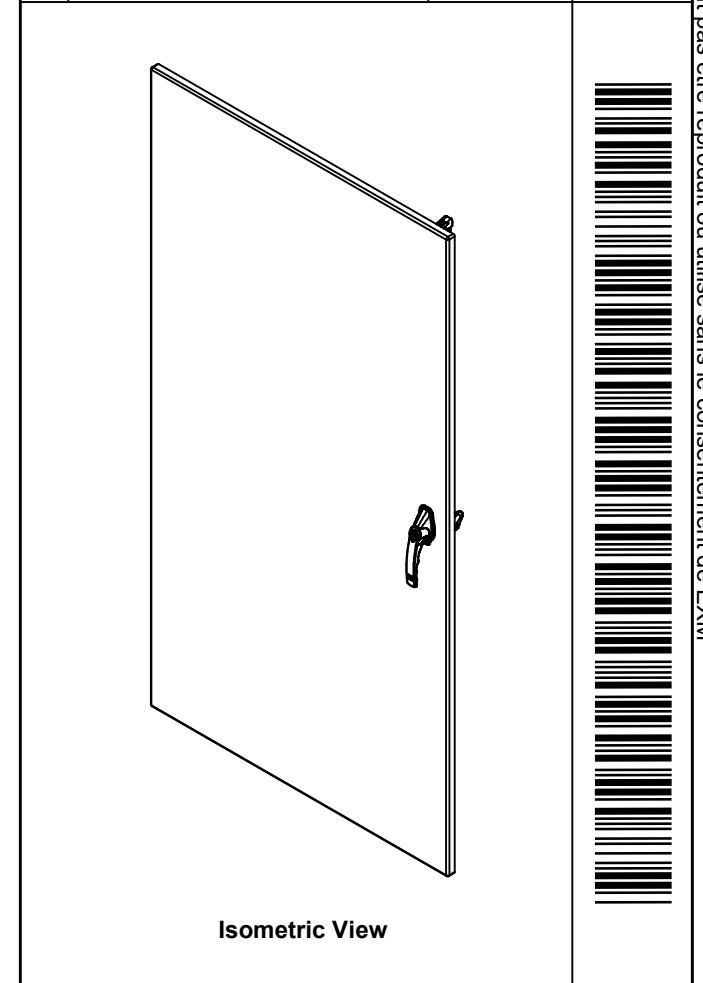

| | | | |
|---|-----------------|---|--|
| 1 | STK-Q-47562 | 0 | 9500 Lower Closing Bar 72" (cam) |
| 1 | STK-Q-47552 | 0 | 9500 Upper Closing Bar 72" (cam) |
| 2 | STK-Q-07220 | 1 | M6 Nylon Insert Lock Nut |
| 1 | STK-A-50538 | 3 | 9500 Handle Cam Assembly (Right Side, Grip 36mm) |
| 1 | STK-Q-90051 | 3 | 5412 ES - Handle Cam Spacer |
| 1 | 885ESL2A-APHK | 7 | 885 ESL2A-APHK - Zinc Die Cast L-Handle Padlockable Assy |
| 1 | STK-P-02400S | 0 | Powder Paint (Asa-61 Grey / Smooth) |
| 1 | STK-S-00100 | 0 | 3.5" x 2" Silver Milar Flexcon Sticker |
| 1 | STK-K-10850 | 5 | 9500 - Door Stiffener Assembly |
| 2 | STK-Q-16410 | 0 | Guide Stud - Largel (No Paint Cap Required) |
| 6 | STK-Q-16055 | 1 | M6 x 18mm Stud (No Paint Cap Required) |
| 1 | 9500ST723618G | 0 | 9500 72" x 36" Cover Gasket |
| 1 | 9500ST723618C-P | 0 | 9500 72" x 36" Cover Part |
| 2 | STK-A-90025 | 0 | 9500 - Cabinet Closing Bar End (Large) |
| 4 | STK-K-09860 | 7 | Cabinet Hinge with Captive Pins |

| QTY | Part Number | Rev | Description |
|------------|-------------|-----|-------------|
| Parts List | | | |

| | | |
|---|---|-----------------------|
| <p>Tél: (450) 979-4373 Fax: (450) 979-4626 www.exmweb.com</p> | Flatness Aplatissement | Max 3.0mm |
| | Projection | |
| Customer Client | Date | |
| Drawn By Dessiné Par | BoxCad: BoxCad | Date 09-Dec-21 |
| Material Matière | 12 Ga Cold Rolled A1008 CS Type B (2.5mm) | |
| Color Couleur | Asa-61 Grey | Finish Fini Smooth |
| Description | 9500 72" x 36" Cover | |
| Part Number Numéro Pièce | Rev. 0 | 11 / 11 |
| 9500ST723618C | | |