

This drawing is confidential and must not be reproduced or used without the consent of EXM

Ce dessin est confidentiel et ne doit pas être reproduit ou utilisé sans le consentement de EXM

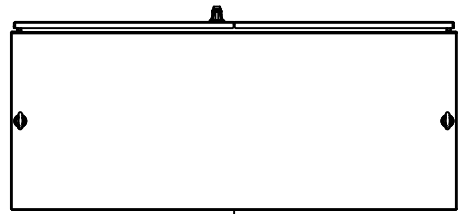

TOP



BACK

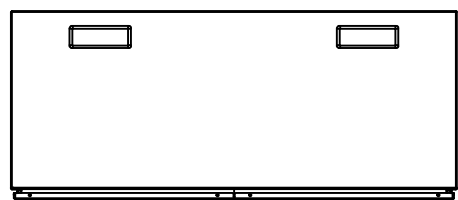

BOTTOM

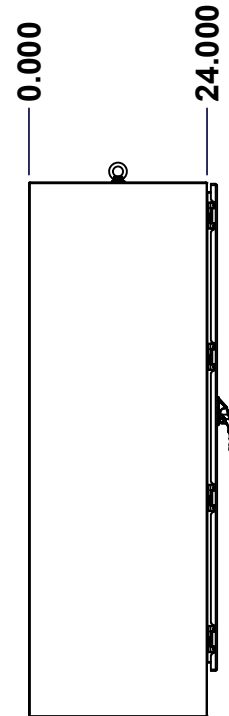

LEFT

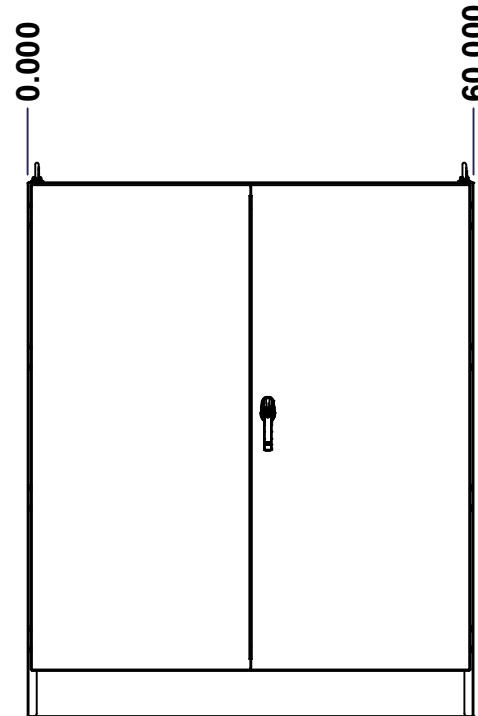

FRONT

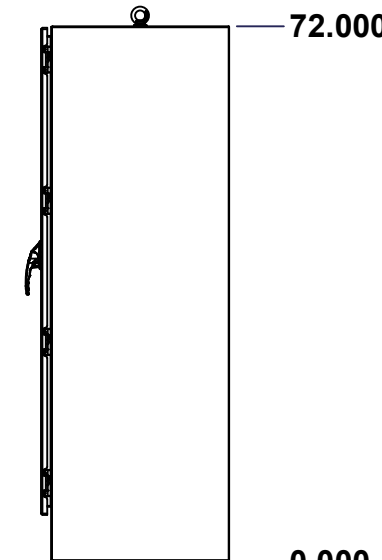

RIGHT

No.	Revisions	Date	By/Par

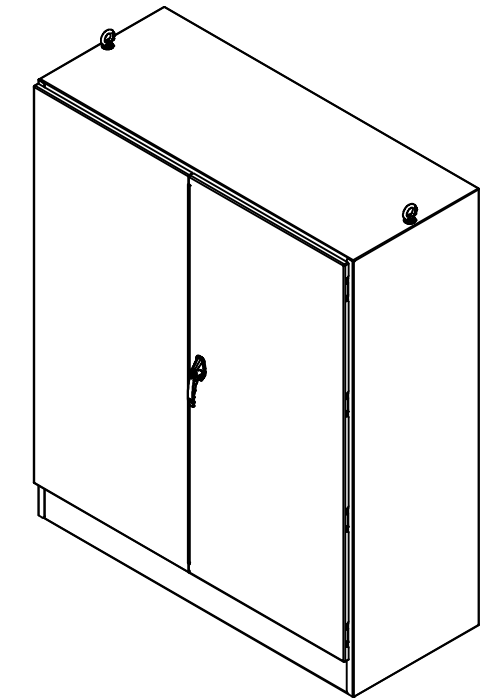

Isometric View



Tél: (450) 979-4373
 Fax: (450) 979-4626
www.exmweb.com

Flatness
Aplatissement

Max 3.0mm

Projection



Customer Client	Date
Drawn By / Dessiné Par: BoxCad: BoxCad	Date: 08-Dec-21
Material / Matière: 12 Ga Cold Rolled A1008 CS Type B (2.5mm)	

Color / Couleur: Asa-61 Grey	Finish / Fini: Smooth
------------------------------	-----------------------

Description: 9500DD 72" x 60" x 24" Assembly	Detail Rev.
--	-------------

Part Number / Numéro Pièce: 9500STDD726024	Rev. 0	1
--	--------	---

SEE BILL OF MATERIAL ON LAST PAGE

This drawing is confidential and must not be reproduced or used without the consent of EXM

Ce dessin est confidentiel et ne doit pas être reproduit ou utilisé sans le consentement de EXM

NOTE	
ITEM	DESCRIPTION
1	NEMA 12, 13 Enclosure (IP55)
2	C/W Standard ground studs on box and cover
3	C/W Standard door stiffener
4	W/O Inner panel
5	C/W Standard inner panel mounting studs
6	C/W Eyebolts sold separately (Installed by EXM)
7	C/W Struts installed (Included)

No.	Revisions	Date	By/Par

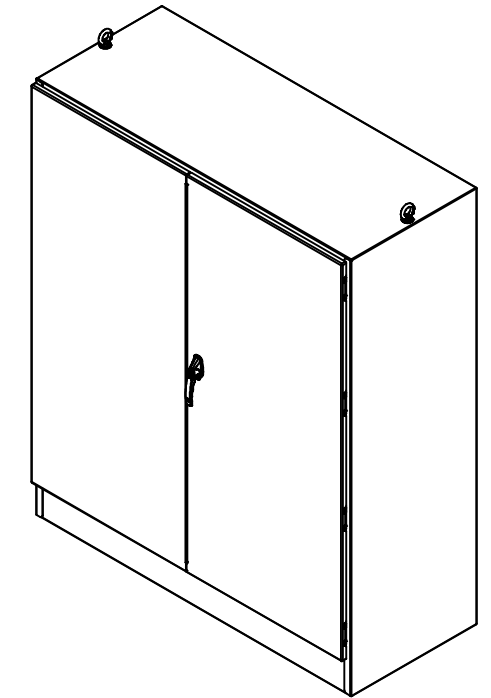

Isometric View



Tél: (450) 979-4373
Fax: (450) 979-4626
www.exmweb.com

Flatness
Aplatissement
Max 3.0mm

Projection



PACKING		
ITEM	QTY	DESCRIPTION
Cardboard sleeve	2	Top and Bottom
Cardboard strip	2	Between back of enclosure and inner panel
Plastic bag	1	To protect cover surface and inside gasket
Cardboard corner	4	To reinforced for the plastic strap tightening
Plastic strap - Black	2	To Squeeze 2 cardboard sleeve together
Packaging label	3	White label with PN
Plastic strap- Green	2	To secure the enclosure to the wood pallet
Wood Pallet	1	2" deeper and 3" larger than enclosure size

1	880EB14	2	Eye Bolt M14 (Pack of 2)
1	9500STDD726024FD	0	9500DD 72" x 60" Flange Door
1	9500STDD726024LD	0	9500DD 72" x 60" Lock Door
1	9500STDD726024B	0	9500DD 72" x 60" x 24" Body
2	9500STDD726024GP	0	9500DD Gland Plate
8	STK-Q-04050-10	8	M6 x 10mm Hexagon Socket Head Machine Screw with Nyseal
Qty	Part Number	Rev	Description
Parts List			

Customer Client	Date
Drawn By Dessiné Par	BoxCad: BoxCad
Date	08-Dec-21
Material Matière	12 Ga Cold Rolled A1008 CS Type B (2.5mm)
Color Couleur	Asa-61 Grey
Finish Fini	Smooth
Description	9500DD 72" x 60" x 24" Assembly
Part Number Numéro Pièce	9500STDD726024
Rev.	2
	0
	15

This drawing is confidential and must not be reproduced or used without the consent of EXM

Ce dessin est confidentiel et ne doit pas être reproduit ou utilisé sans le consentement de EXM

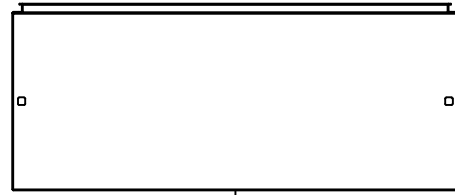

TOP

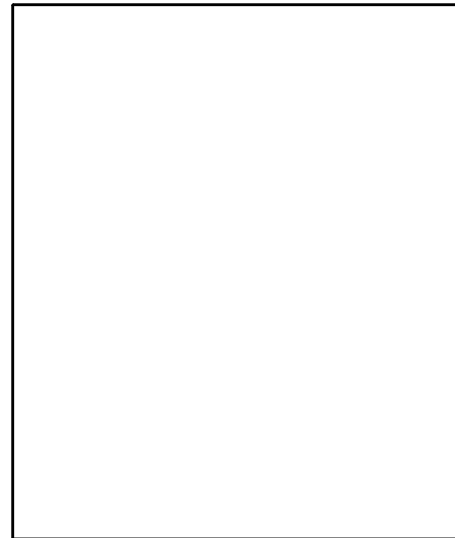

BACK

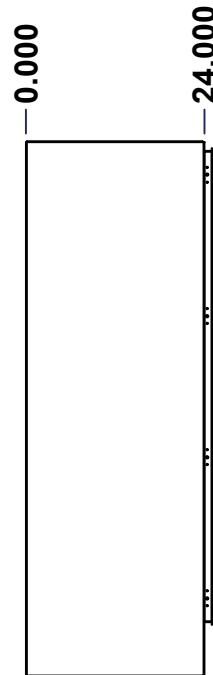

LEFT

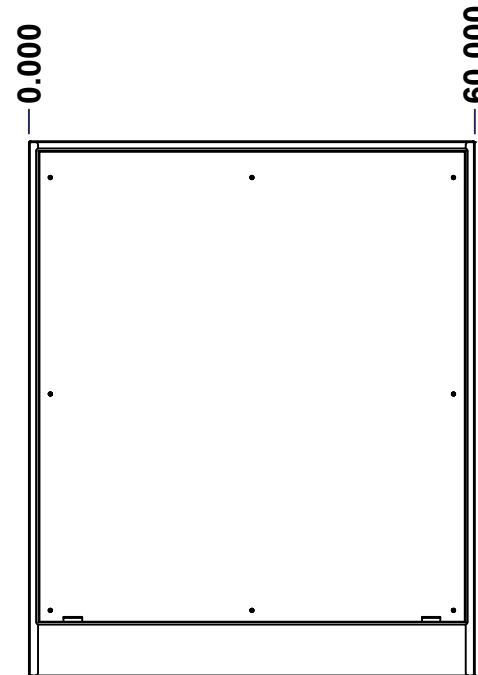

FRONT

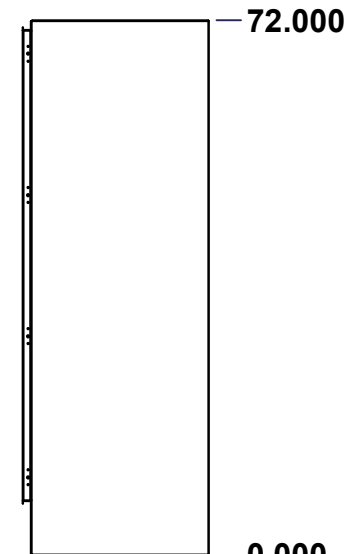

RIGHT

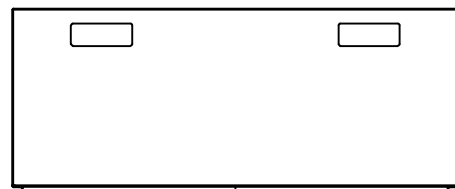

BOTTOM

No.	Revisions	Date	By/Par

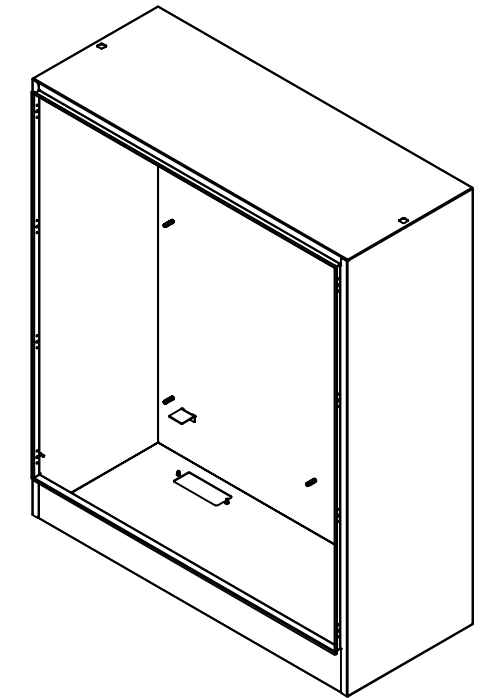

Isometric View



Tél: (450) 979-4373
 Fax: (450) 979-4626
www.exmweb.com

Flatness
Aplatissement

Max 3.0mm

Projection

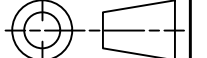

Customer Client	Date
Drawn By Dessiné Par BoxCad: BoxCad	Date 08-Dec-21
Material Matière 12 Ga Cold Rolled A1008 CS Type B (2.5mm)	

Color Couleur Asa-61 Grey	Finish Fini Smooth
------------------------------	-----------------------

Description 9500DD 72" x 60" x 24" Body	Detail Rev.
--	-------------

Part Number Numéro Pièce 9500STDD726024B	Rev. 0	3
--	---------------	---

SEE BILL OF MATERIAL ON LAST PAGE

This drawing is confidential and must not be reproduced or used without the consent of EXM

Ce dessin est confidentiel et ne doit pas être reproduit ou utilisé sans le consentement de EXM

STANDARD FEATURES ARE NOT LISTED IN THIS HOLE TABLE

HOLE TABLE - TOP VIEW (CUSTOM FEATURE ONLY)

CUT-OUT	XDIM	YDIM	DESCRIPTION
1	45.000	20.000	Struts CR400 21.500" (Inside)
2	15.000	20.000	Struts CR400 21.500" (Inside)
3	45.000	20.929	STUDS M6 x 10mm (Inside)
4	55.866	20.000	STUDS M6 x 10mm (Inside)
5	15.000	20.929	STUDS M6 x 10mm (Inside)
6	25.866	20.000	STUDS M6 x 10mm (Inside)

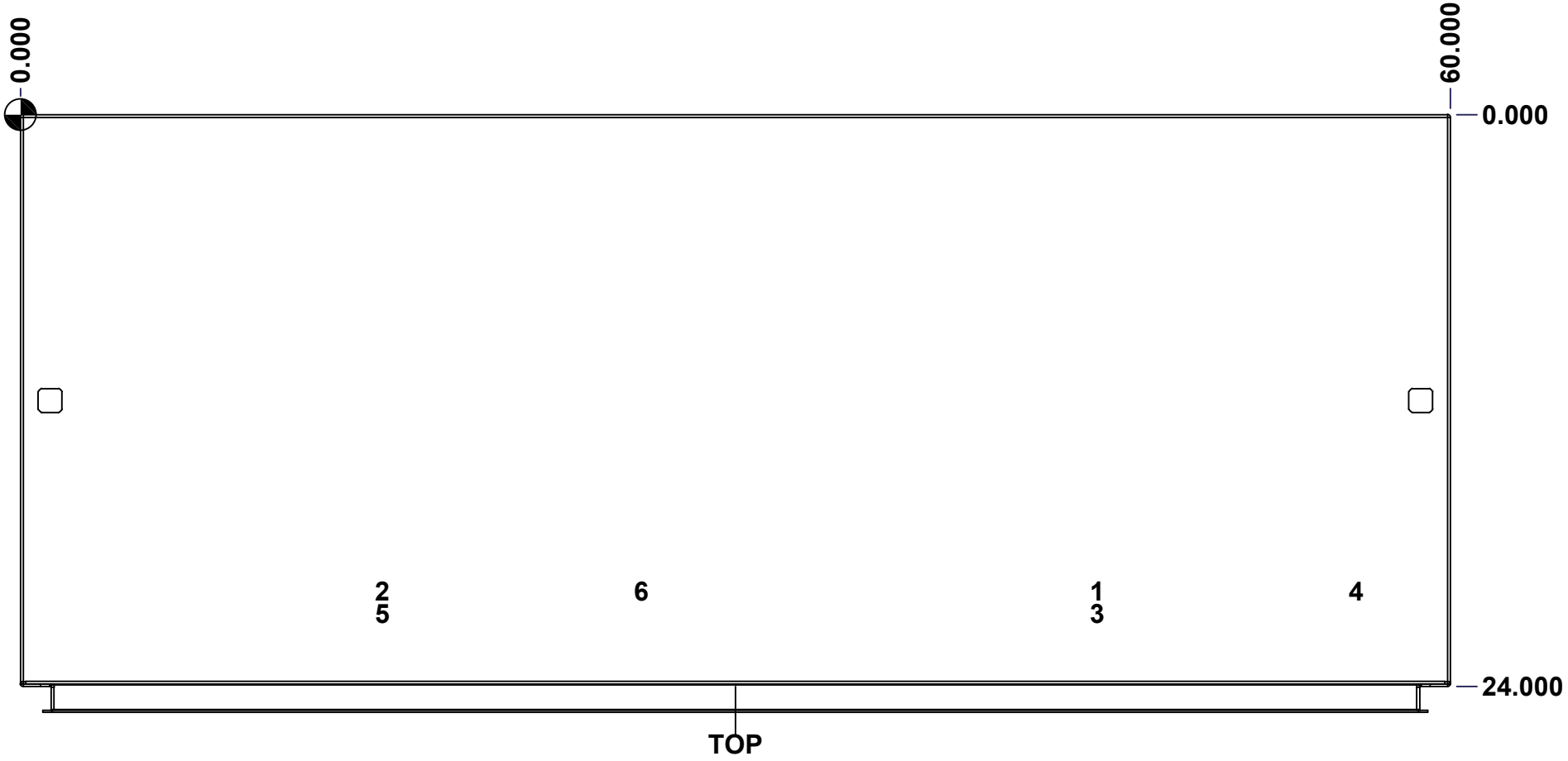

	Description	Status
	9500DD 72" x 60" x 24" Body	(NULL)
Part Number Numéro Pièce 9500STDD726024B	Rev.	4
	0	15

This drawing is confidential and must not be reproduced or used without the consent of EXM

Ce dessin est confidentiel et ne doit pas être reproduit ou utilisé sans le consentement de EXM

STANDARD FEATURES ARE NOT LISTED IN THIS HOLE TABLE			
HOLE TABLE - RIGHT VIEW (CUSTOM FEATURE ONLY)			
CUT-OUT	XDIM	YDIM	DESCRIPTION
1	22.500	9.375	GND STUD M6 x 16mm (Inside)

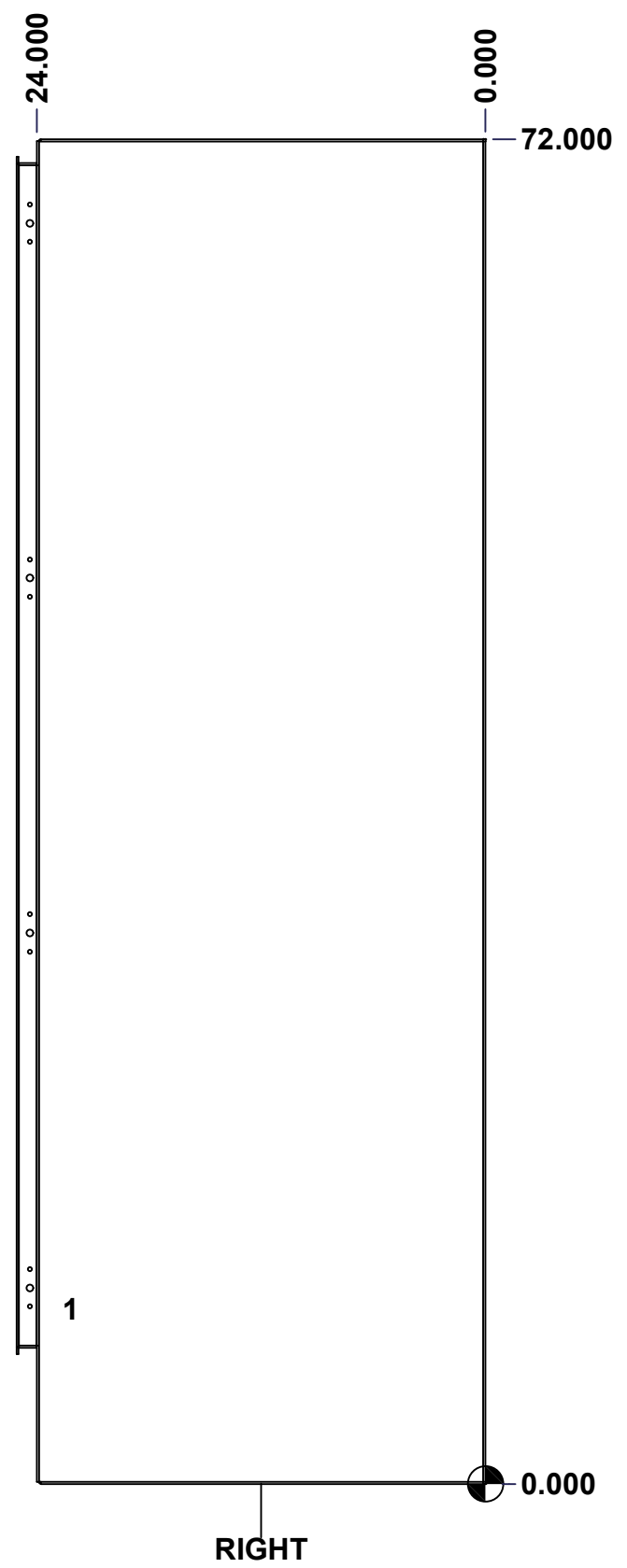

	Description	Status
	9500DD 72" x 60" x 24" Body	(NULL)
Part Number Numéro Pièce 9500STDD726024B	Rev.	5
	0	15

This drawing is confidential and must not be reproduced or used without the consent of EXM

Ce dessin est confidentiel et ne doit pas être reproduit ou utilisé sans le consentement de EXM

STANDARD FEATURES ARE NOT LISTED IN THIS HOLE TABLE

HOLE TABLE - BOTTOM VIEW (CUSTOM FEATURE ONLY)

CUT-OUT	XDIM	YDIM	DESCRIPTION
1	7.375	3.500	GP STUD M6 x 16mm (Inside)
2	16.625	3.500	GP STUD M6 x 16mm (Inside)
3	43.375	3.500	GP STUD M6 x 16mm (Inside)
4	52.625	3.500	GP STUD M6 x 16mm (Inside)

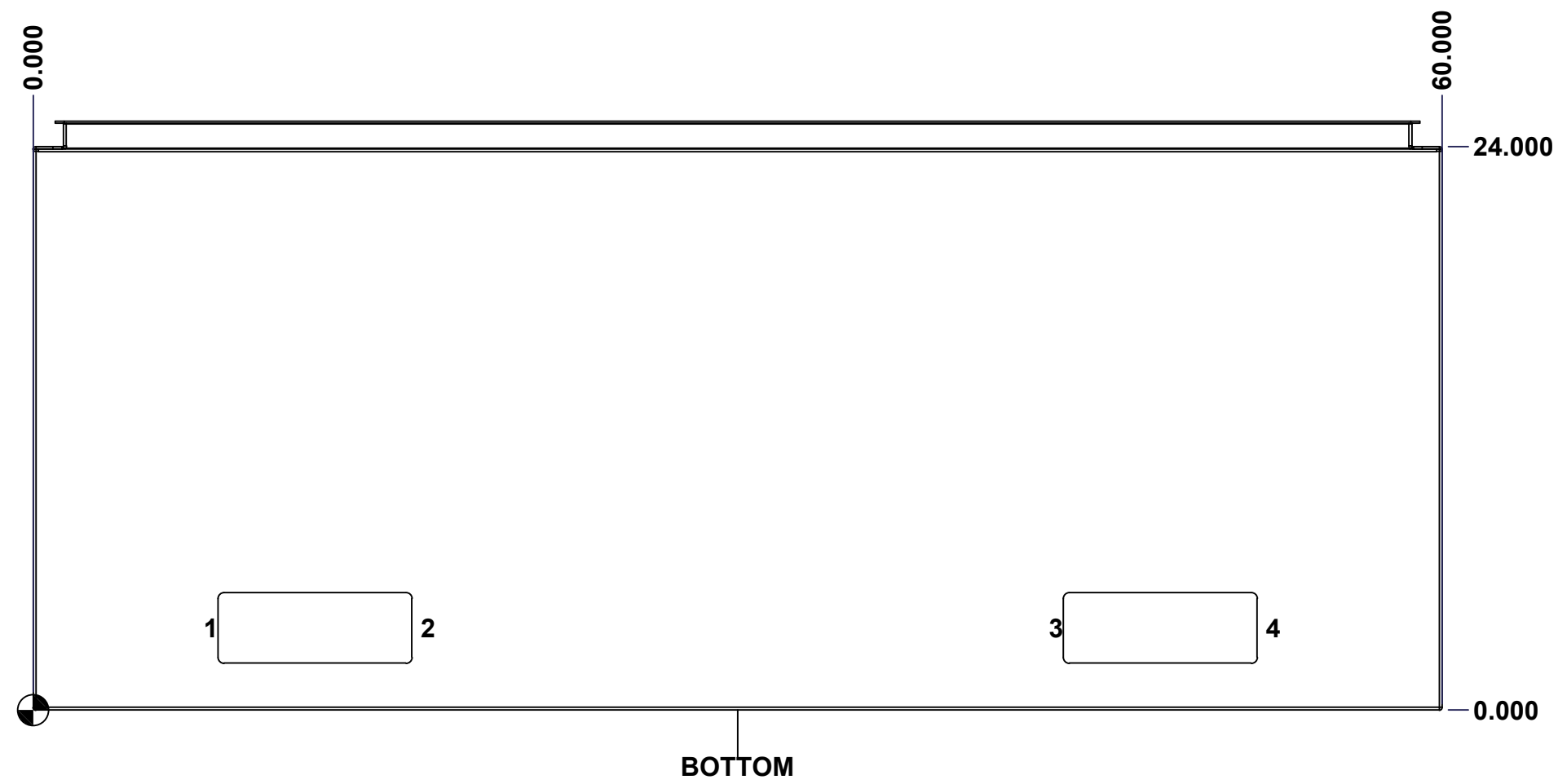

	Description	Status
	9500DD 72" x 60" x 24" Body	(NULL)
	Part Number Numéro Pièce	Rev.
	9500STDD726024B	0 / 6
		15

This drawing is confidential and must not be reproduced or used without the consent of EXM

Ce dessin est confidentiel et ne doit pas être reproduit ou utilisé sans le consentement de EXM

STANDARD FEATURES ARE NOT LISTED IN THIS HOLE TABLE			
HOLE TABLE - LEFT VIEW (CUSTOM FEATURE ONLY)			
CUT-OUT	XDIM	YDIM	DESCRIPTION
1	22.500	9.375	GND STUD M6 x 16mm (Inside)

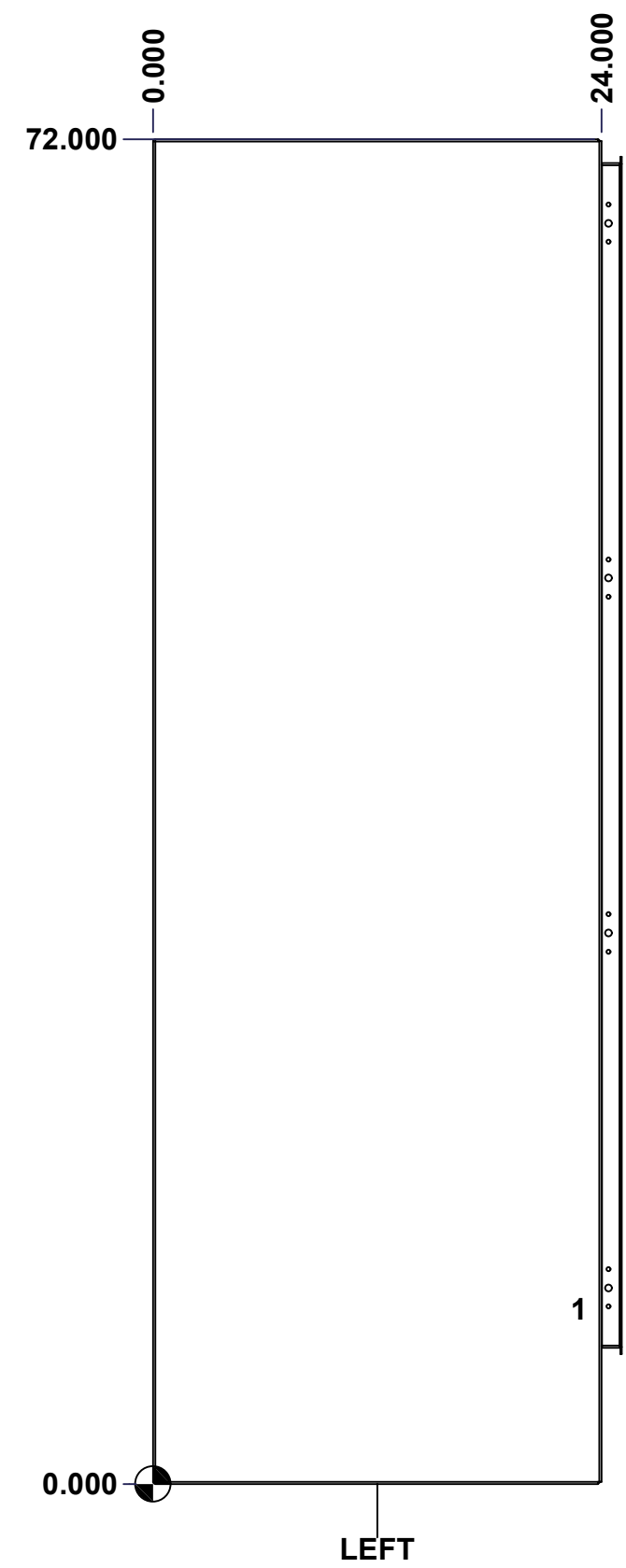

	Description	Status
	9500DD 72" x 60" x 24" Body	(NULL)
Part Number Numéro Pièce 9500STDD726024B	Rev.	7
	0	15

This drawing is confidential and must not be reproduced or used without the consent of EXM

Ce dessin est confidentiel et ne doit pas être reproduit ou utilisé sans le consentement de EXM

STANDARD FEATURES ARE NOT LISTED IN THIS HOLE TABLE

HOLE TABLE - BACK VIEW (CUSTOM FEATURE ONLY)

CUT-OUT	XDIM	YDIM	DESCRIPTION
1	2.875	8.875	IP STUD M10 x 40mm (Inside)
2	57.125	8.875	IP STUD M10 x 40mm (Inside)
3	2.875	38.000	IP STUD M10 x 40mm (Inside)
4	57.125	38.000	IP STUD M10 x 40mm (Inside)
5	2.875	67.125	IP STUD M10 x 40mm (Inside)
6	57.125	67.125	IP STUD M10 x 40mm (Inside)
7	30.000	8.875	IP STUD M10 x 40mm (Inside)
8	30.000	67.125	IP STUD M10 x 40mm (Inside)
-----	-----	-----	-----
9	5.875	7.500	IP SUPPORT ANGLE (Inside)
10	54.125	7.500	IP SUPPORT ANGLE (Inside)

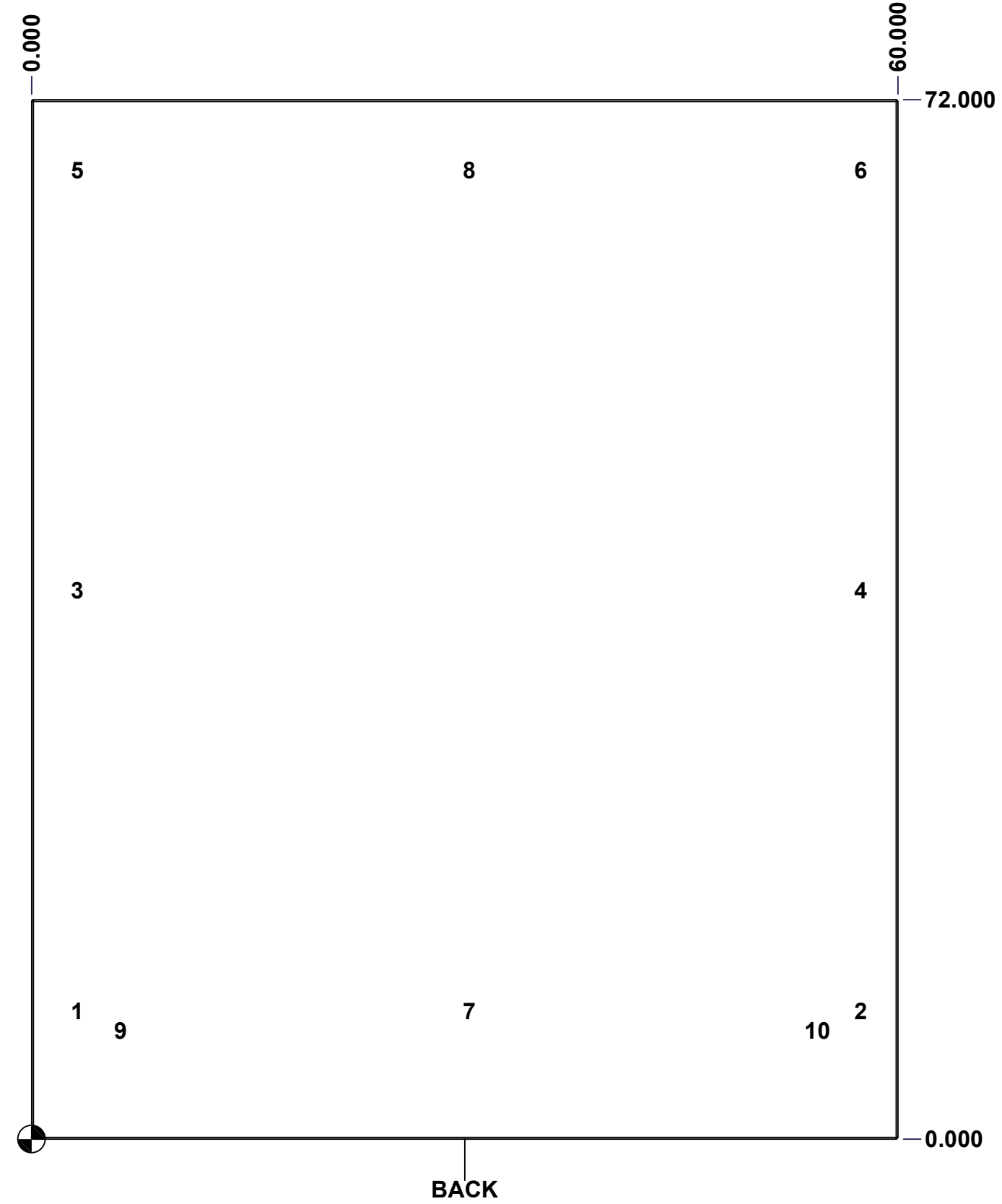

	Description	Status
	9500DD 72" x 60" x 24" Body	(NULL)
	Part Number Numéro Pièce	Rev.
	9500STDD726024B	0 / 8
		15

This drawing is confidential and must not be reproduced or used without the consent of EXM

Ce dessin est confidentiel et ne doit pas être reproduit ou utilisé sans le consentement de EXM

No.	Revisions	Date	By/Par

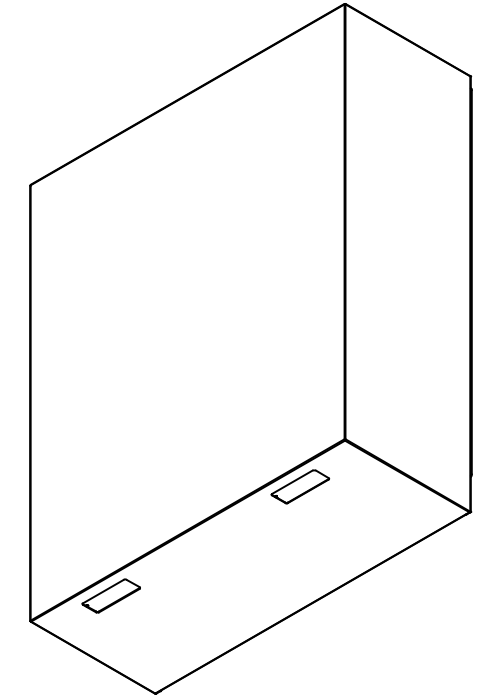

Isometric View

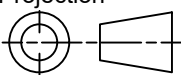

Qty	Part Number	Rev	Description
4	STK-Q-16030	0	Stud M6 x 10mm Steel
2	9500STDD726024BPA-P	0	9500DD Inner Panel Support Angle
1	STK-P-02400S	0	Powder Paint (Asa-61 Grey / Smooth)
2	STK-Q-74910	0	Eyebolt Lifting Angle (15.500")
8	STK-Q-16100	0	Stud M10 x 40mm Steel
1	9500STDD726024B-P	0	9500DD 72" x 60" Body Part
2	9500STDD726024_CR400 MS_21.5	0	Commercial Roll Mild Steel (21.5in long)
6	STK-Q-16080	0	Ground Stud M6 x 16mm Steel

 Tél: (450) 979-4373 Fax: (450) 979-4626 www.exmweb.com		Flatness Aplatissement Max 3.0mm
Customer Client		Projection 
Drawn By Dessiné Par BoxCad: BoxCad		Date 08-Dec-21
Material Matière 12 Ga Cold Rolled A1008 CS Type B (2.5mm)		
Color Couleur Asa-61 Grey	Finish Fini Smooth	
Description 9500DD 72" x 60" x 24" Body		Detail Rev.
Part Number Numéro Pièce 9500STDD726024B		Rev. 0

This drawing is confidential and must not be reproduced or used without the consent of EXM

Ce dessin est confidentiel et ne doit pas être reproduit ou utilisé sans le consentement de EXM

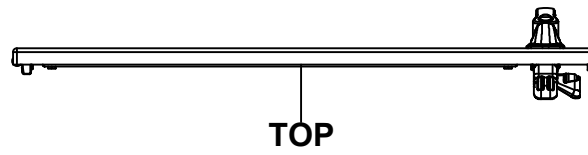

TOP

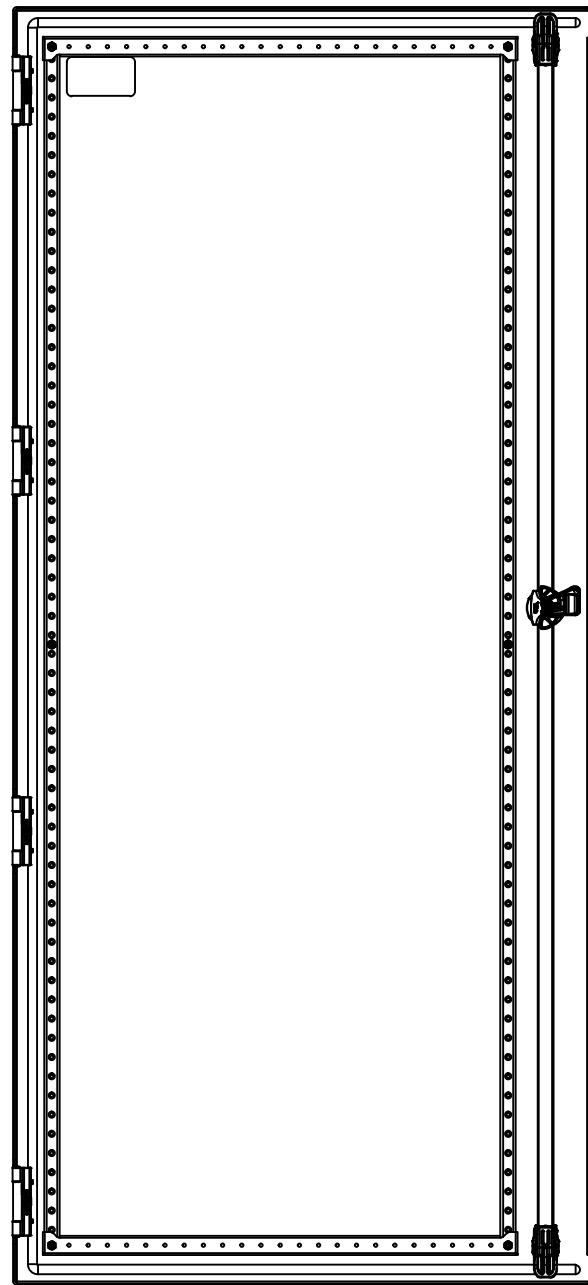

BACK



BOTTOM

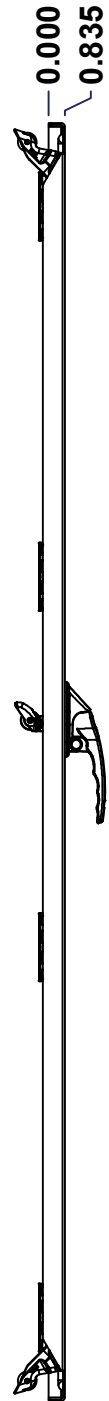

LEFT

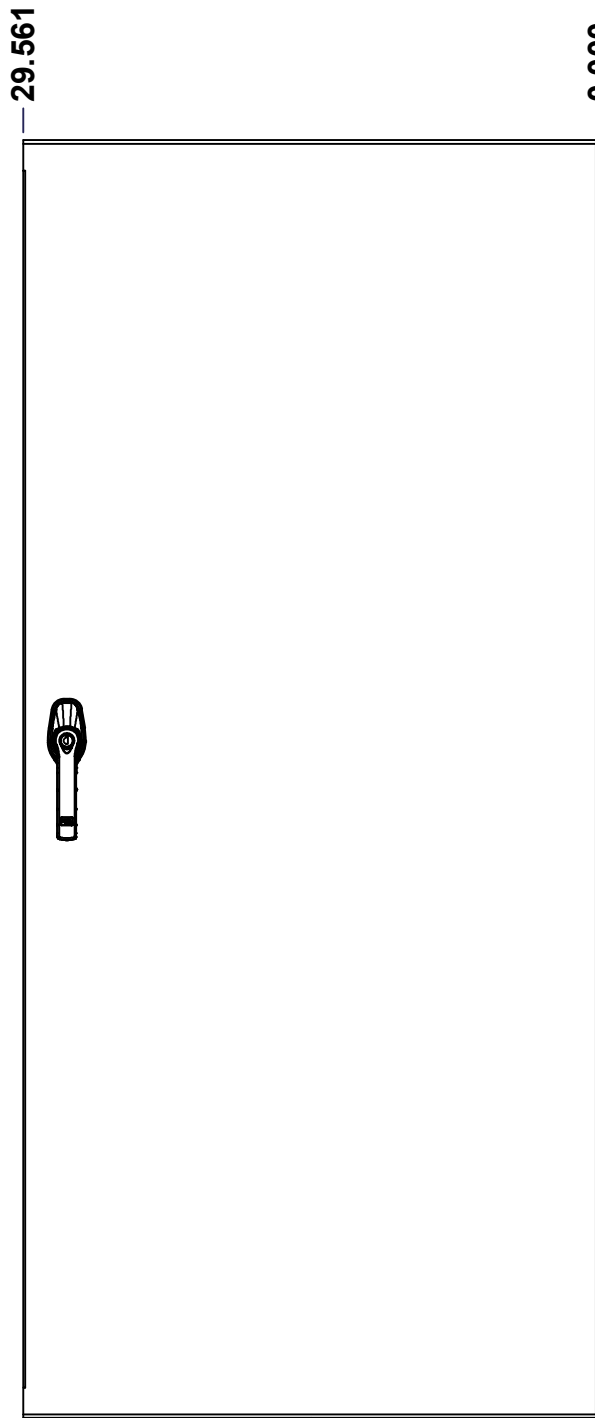

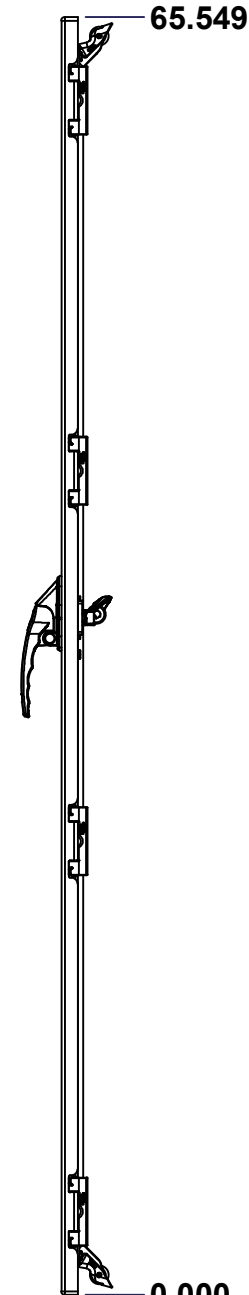

FRONT

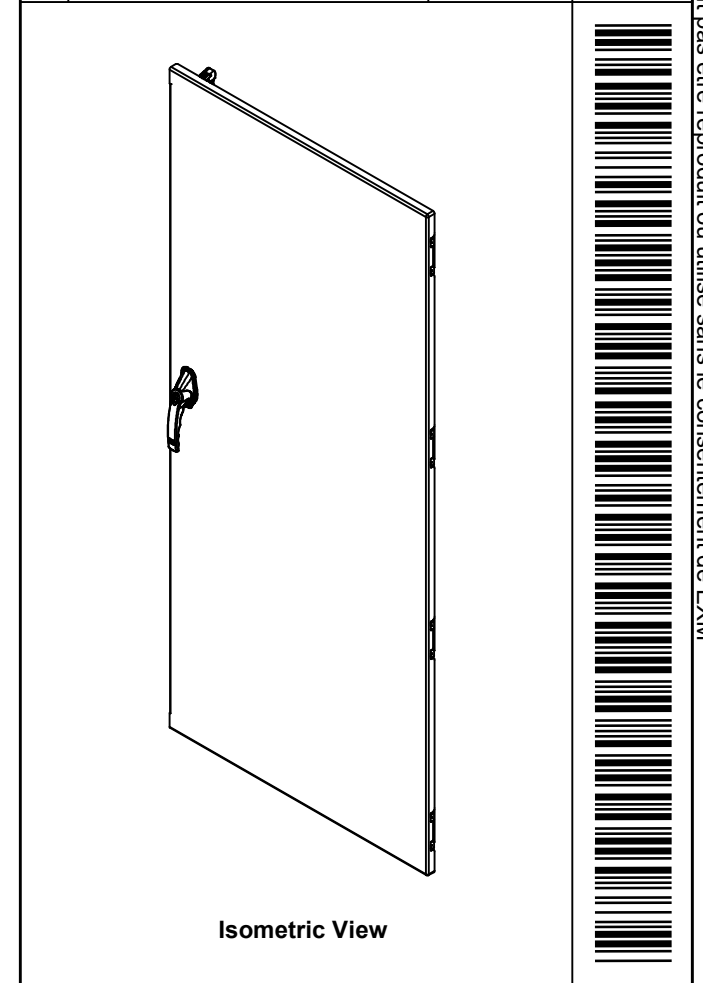

RIGHT

No.	Revisions	Date	By/Par

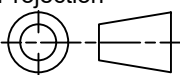

 Tél: (450) 979-4373 Fax: (450) 979-4626 www.exmweb.com		Flatness Aplatissement Max 3.0mm Projection 
Customer Client	Date	
Drawn By Dessiné Par	BoxCad: BoxCad	Date 08-Dec-21
Material Matière	12 Ga Cold Rolled A1008 CS Type B (2.5mm)	
Color Couleur	Asa-61 Grey	Finish Fini Smooth
Description		Detail Rev.
9500DD 72" x 60" Lock Door		
Part Number Numéro Pièce	Rev.	10
9500STDD726024LD	0	15

SEE BILL OF MATERIAL ON LAST PAGE

This drawing is confidential and must not be reproduced or used without the consent of EXM

Ce dessin est confidentiel et ne doit pas être reproduit ou utilisé sans le consentement de EXM

STANDARD FEATURES ARE NOT LISTED IN THIS HOLE TABLE			
HOLE TABLE - FRONT VIEW (CUSTOM FEATURE ONLY)			
CUT-OUT	XDIM	YDIM	DESCRIPTION
1	1.983	2.028	STUD M6 x 18mm (Inside)
2	1.983	32.854	STUD M6 x 18mm (Inside)
3	1.983	63.521	STUD M6 x 18mm (Inside)
4	25.390	2.028	STUD M6 x 18mm (Inside)
5	25.390	32.854	STUD M6 x 18mm (Inside)
6	25.390	63.521	STUD M6 x 18mm (Inside)
7	27.311	6.118	LARGE CBAR GUIDE (Inside)
8	27.311	59.431	LARGE CBAR GUIDE (Inside)
-----	-----	-----	-----
9	27.311	34.743	HANDLE 885 ESL2A-APHK @ 0.0°

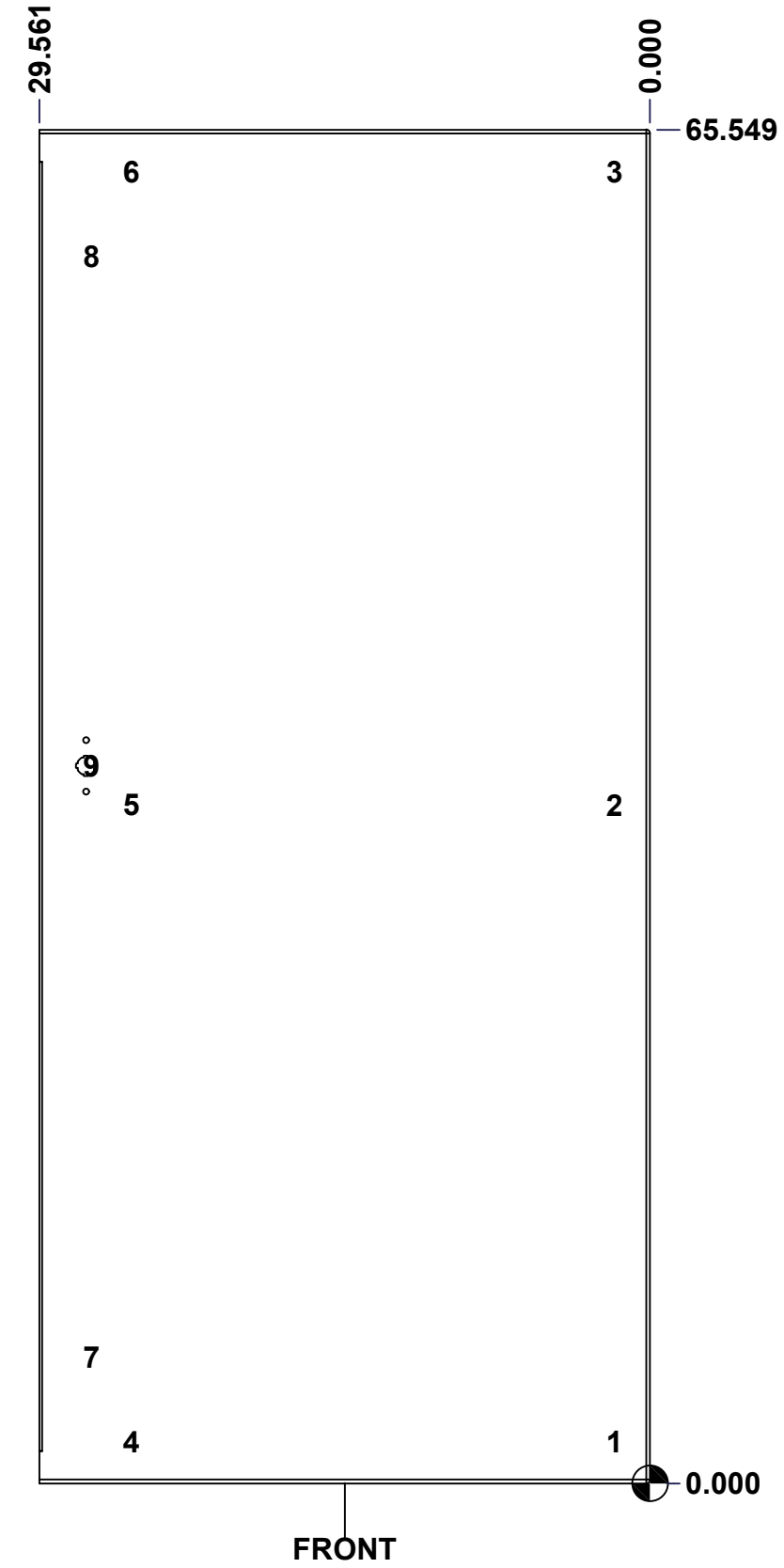

FRONT

	Description	Status
	9500DD 72" x 60" Lock Door	(NULL)
Part Number Numéro Pièce 9500STDD726024LD	Rev.	11
	0	15

This drawing is confidential and must not be reproduced or used without the consent of EXM

Ce dessin est confidentiel et ne doit pas être reproduit ou utilisé sans le consentement de EXM

No.	Revisions	Date	By/Par

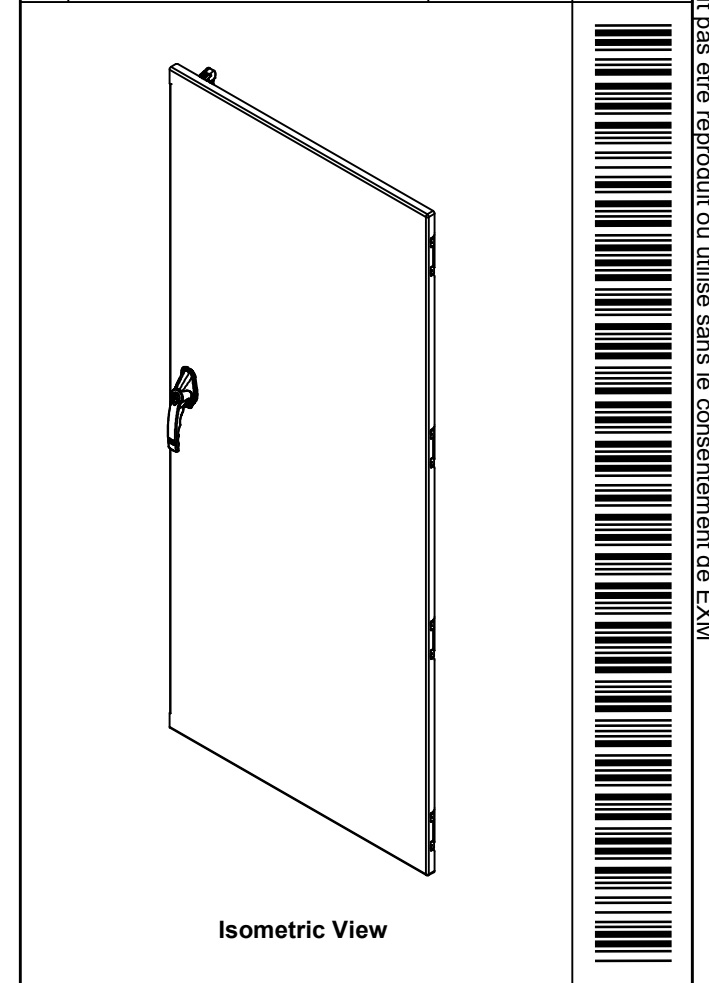

2	STK-Q-07220	1	M6 Nylon Insert Lock Nut
1	STK-Q-47562	0	9500 Lower Closing Bar 72" (cam)
1	STK-Q-47552	0	9500 Upper Closing Bar 72" (cam)
1	STK-A-50537	3	9500 Handle Cam Assembly (Left Side, Grip 36mm)
1	STK-Q-90051	3	5412 ES - Handle Cam Spacer
1	885ESL2A-APHK	7	885 ESL2A-APHK - Zinc Die Cast L-Handle Padlockable Assy
1	STK-P-02400S	0	Powder Paint (Asa-61 Grey / Smooth)
1	STK-S-00100	0	3.5" x 2" Silver Milar Flexcon Sticker
1	STK-K-10840	5	9500 - Door Stiffener Assembly
2	STK-Q-16410	0	Guide Stud - Largel (No Paint Cap Required)
6	STK-Q-16055	1	M6 x 18mm Stud (No Paint Cap Required)
1	9500STDD726024LDG	0	9500DD 72" x 60" Lock Door Gasket
1	9500STDD726024LD-P	0	9500DD 72" x 60" Lock Door Part
2	STK-A-90025	0	9500 - Cabinet Closing Bar End (Large)
4	STK-K-09860	7	Cabinet Hinge with Captive Pins

QTY	Part Number	Rev	Description
Parts List			

	Tél: (450) 979-4373 Fax: (450) 979-4626 www.exmweb.com	Flatness Aplatissement Max 3.0mm
	Projection 	Customer Client
Drawn By Dessiné Par	BoxCad: BoxCad	Date 08-Dec-21
Material Matière	12 Ga Cold Rolled A1008 CS Type B (2.5mm)	
Color Couleur	Asa-61 Grey	Finish Fini Smooth
Description 9500DD 72" x 60" Lock Door		Detail Rev.
Part Number Numéro Pièce 9500STDD726024LD		Rev. 0

This drawing is confidential and must not be reproduced or used without the consent of EXM

Ce dessin est confidentiel et ne doit pas être reproduit ou utilisé sans le consentement de EXM



TOP

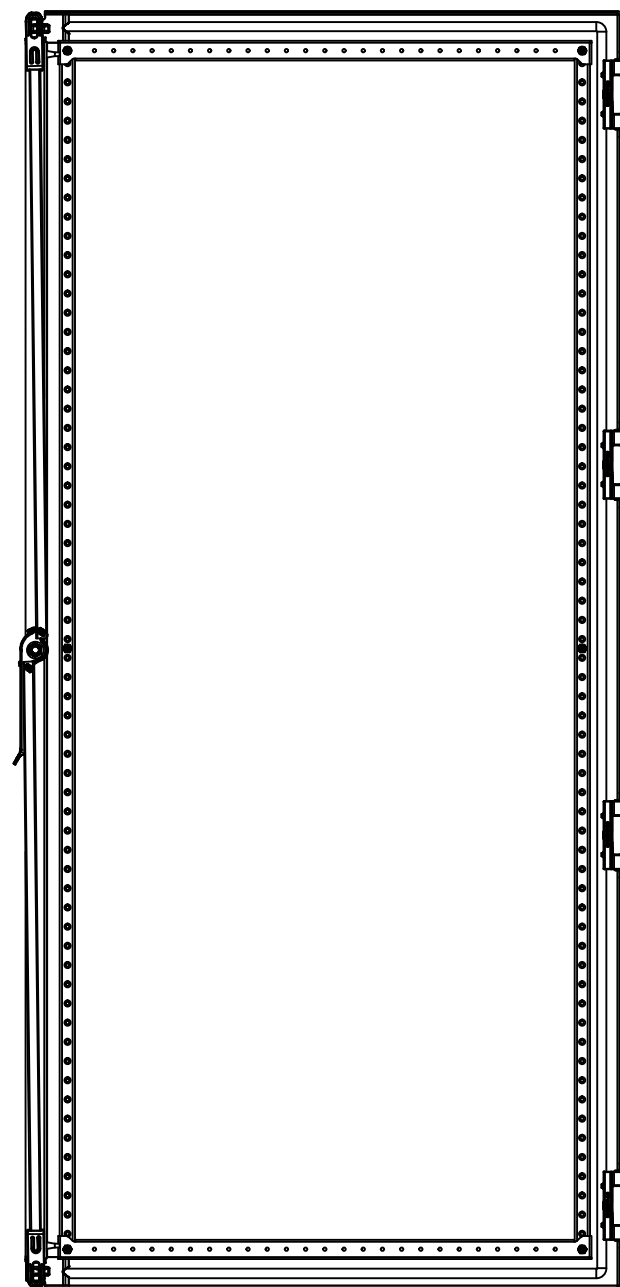

BACK

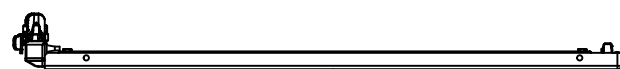

BOTTOM

0.000
0.835



LEFT

0.000

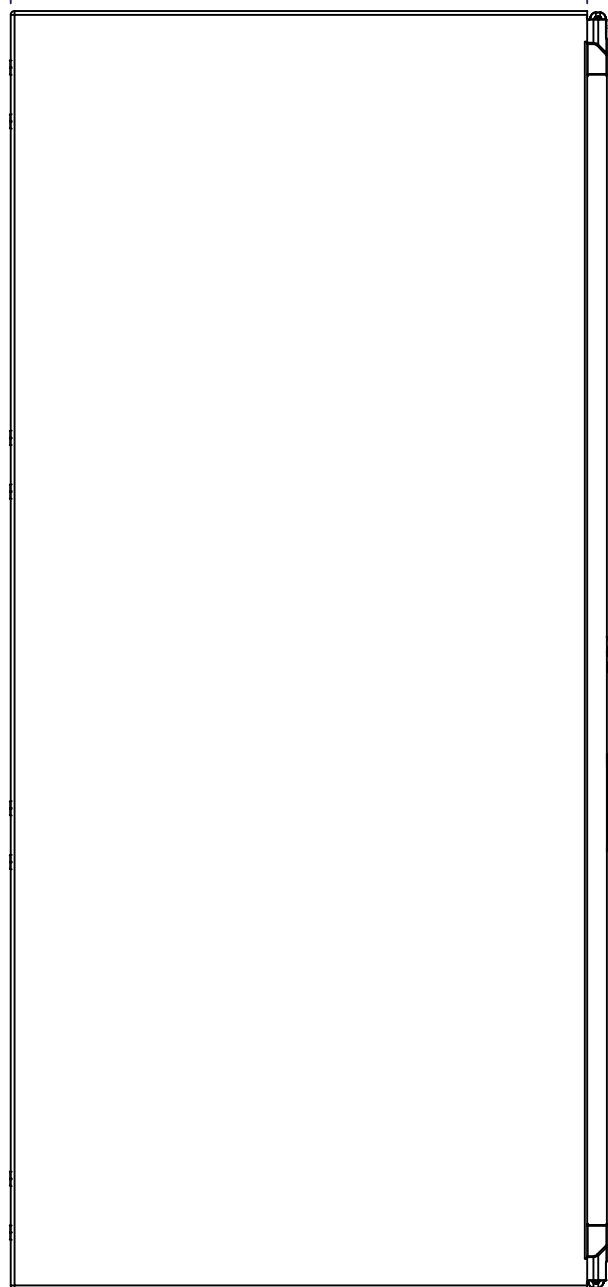

FRONT

29.561

65.549



RIGHT

0.000

No.	Revisions	Date	By/Par

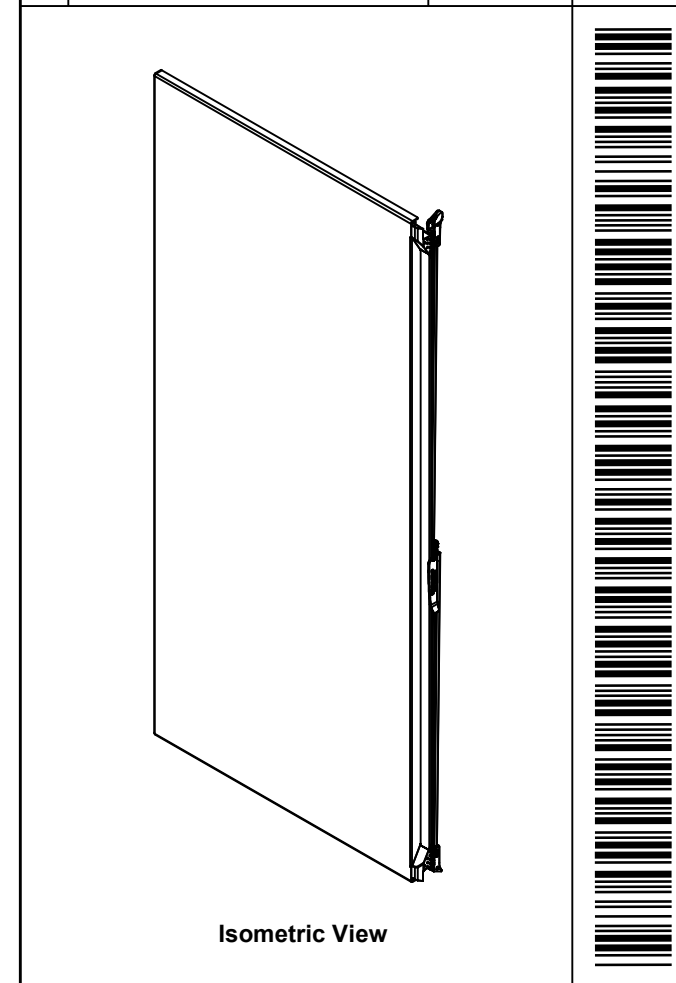

 Tél: (450) 979-4373 Fax: (450) 979-4626 www.exmweb.com		Flatness Aplatissement
		Max 3.0mm
Customer Client		Date
Drawn By Dessiné Par	BoxCad: BoxCad	Date 08-Dec-21
Material Matière 12 Ga Cold Rolled A1008 CS Type B (2.5mm)		
Color Couleur	Asa-61 Grey	Finish Fini Smooth
Description 9500DD 72" x 60" Flange Door		Detail Rev.
Part Number Numéro Pièce	Rev. 0	13 15

SEE BILL OF MATERIAL ON LAST PAGE

9500STDD726024FD

This drawing is confidential and must not be reproduced or used without the consent of EXM

Ce dessin est confidentiel et ne doit pas être reproduit ou utilisé sans le consentement de EXM

STANDARD FEATURES ARE NOT LISTED IN THIS HOLE TABLE

HOLE TABLE - FRONT VIEW (CUSTOM FEATURE ONLY)

CUT-OUT	XDIM	YDIM	DESCRIPTION
1	2.000	2.028	STUD M6 x 18mm (Inside)
2	2.000	32.854	STUD M6 x 18mm (Inside)
3	2.000	63.521	STUD M6 x 18mm (Inside)
4	28.407	2.028	STUD M6 x 18mm (Inside)
5	28.407	32.854	STUD M6 x 18mm (Inside)
6	28.407	63.521	STUD M6 x 18mm (Inside)
7	30.061	4.774	SMALL CBAR GUIDE (Inside)
8	30.061	60.775	SMALL CBAR GUIDE (Inside)
9	30.061	32.774	Carriage Bolt M10 x 28mm

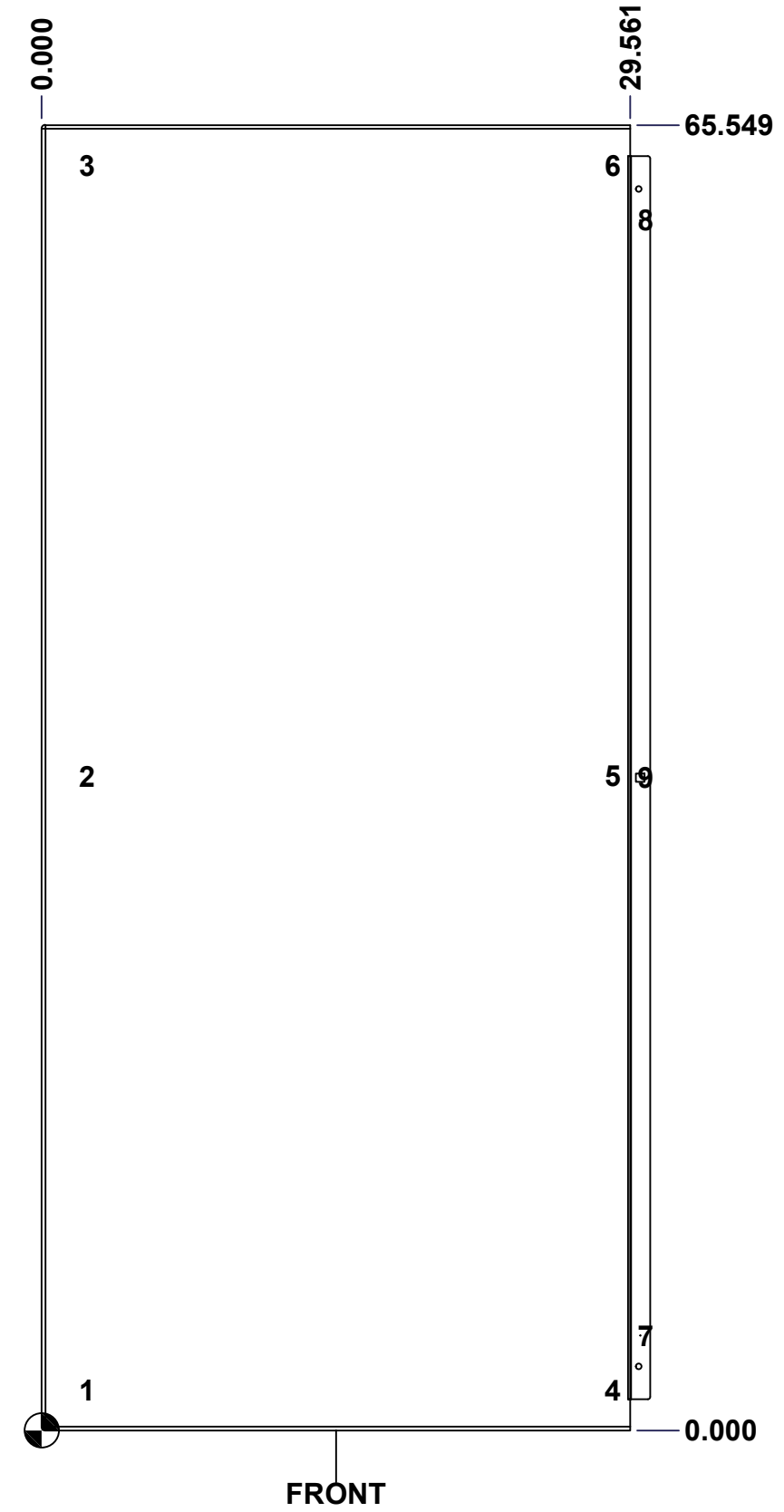

FRONT

	Description	Status
	9500DD 72" x 60" Flange Door	(NULL)
	Part Number	Rev.
	Numéro Pièce	14
	9500STDD726024FD	0
		15

This drawing is confidential and must not be reproduced or used without the consent of EXM

Ce dessin est confidentiel et ne doit pas être reproduit ou utilisé sans le consentement de EXM

No.	Revisions	Date	By/Par

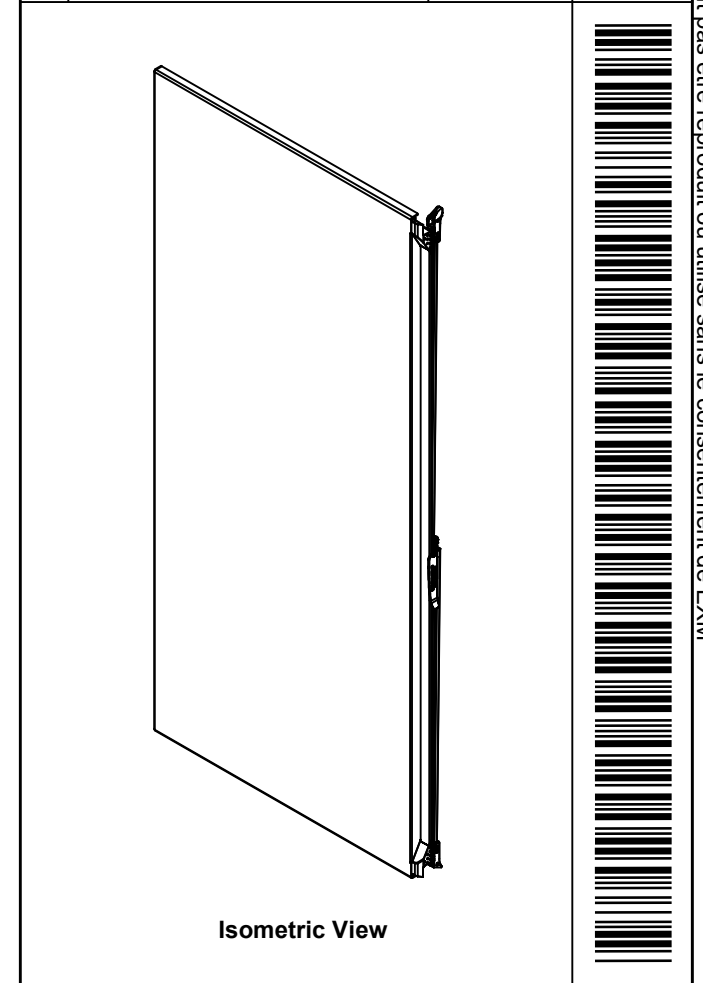

1	STK-P-02400S	0	Powder Paint (Asa-61 Grey / Smooth)
1	STK-G-03400	4	5500 DD Lower Flange Door Gasket
1	STK-G-03300	4	5500 DD Upper Flange Door Gasket
2	STK-Q-90045	1	5500 DDS Flange Door Closing Bar End Assembly
2	STK-Q-45660-72	2	9500 DD - Flange Door Closing Bar
1	STK-Q-07440	0	M10 Nylon Insert Flanged Lock Nut
1	STK-Q-50568	1	Flange Door Handle Spacer
1	STK-A-50556	4	Left Side Flange Door Handle Assembly
1	STK-K-20840	5	9500 - Flange Door Stiffener Assembly
1	STK-Q-00520	2	M10 x 28mm Stainless Steel 316 Carriage Bolt
2	STK-Q-16405	7	Guide Stud - Small (No Paint Cap Required)
6	STK-Q-16055	1	M6 x 18mm Stud (No Paint Cap Required)
1	STK-G-00701	0	1" x 1/4" Self-Adhesive Neoprene Gasket
1	9500STDD726024FDG	0	9500DD 72" x 60" Flange Door Gasket
1	9500STDD726024FD-P	0	9500DD 72" x 60" Flange Door Part
4	STK-K-09860	7	Cabinet Hinge with Captive Pins
QTY	Part Number	Rev	Description
Parts List			

<p>Tél: (450) 979-4373 Fax: (450) 979-4626 www.exmweb.com</p>	Flatness Aplatissement	Max 3.0mm
	Projection	
Customer Client	Date	
Drawn By Dessiné Par	BoxCad: BoxCad	Date 08-Dec-21
Material Matière	12 Ga Cold Rolled A1008 CS Type B (2.5mm)	
Color Couleur	Asa-61 Grey	Finish Fini Smooth
Description	Detail Rev.	
9500DD 72" x 60" Flange Door		
Part Number Numéro Pièce	Rev.	15
9500STDD726024FD	0	15