

This drawing is confidential and must not be reproduced or used without the consent of EXM

Ce dessin est confidentiel et ne doit pas être reproduit ou utilisé sans le consentement de EXM

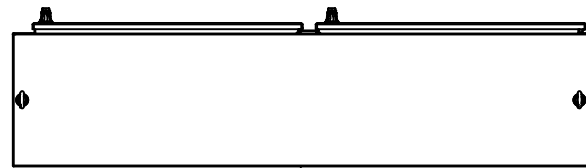

TOP

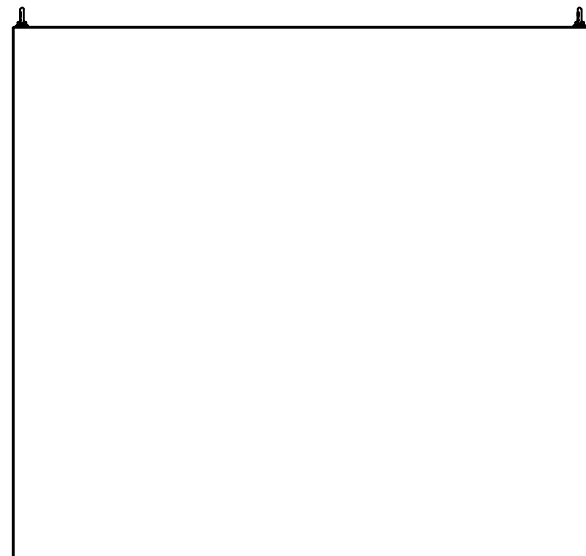

BACK

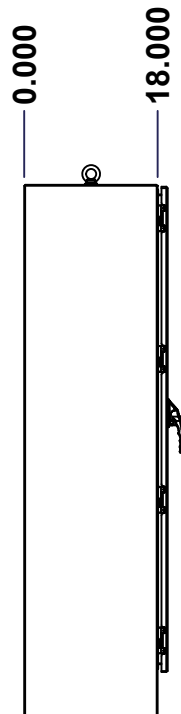

LEFT

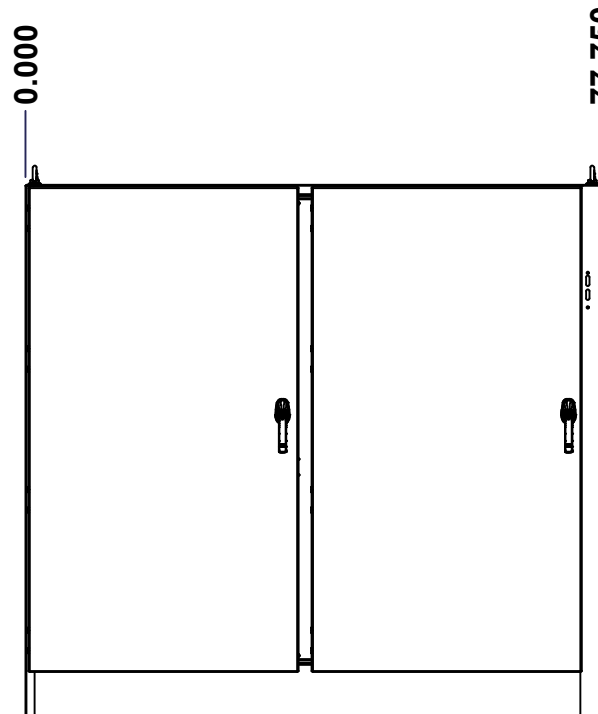

FRONT

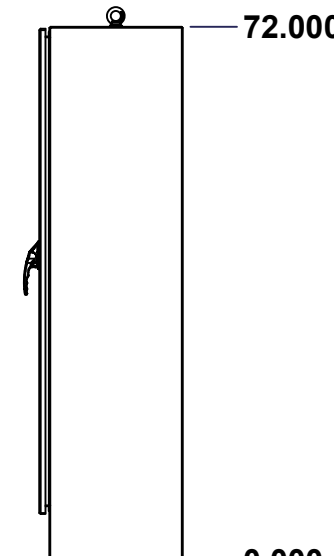

RIGHT

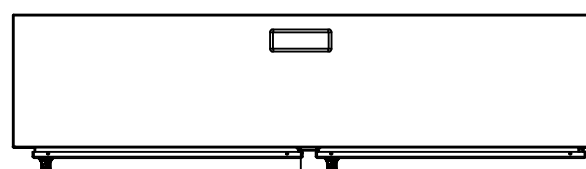

BOTTOM

No.	Revisions	Date	By/Par

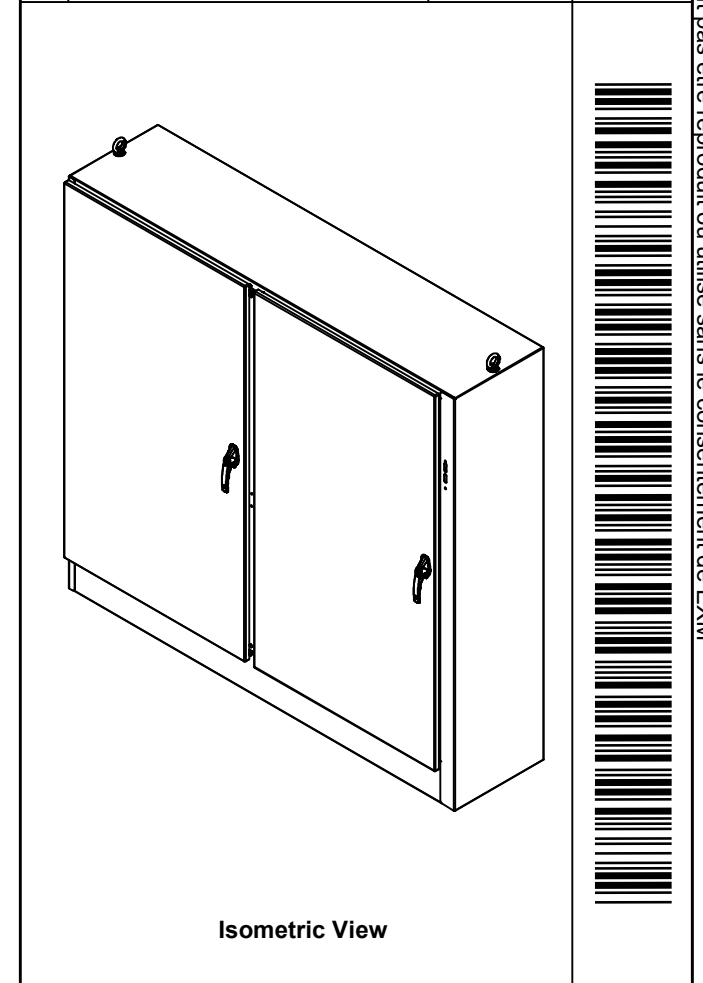

Isometric View

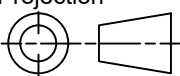
 Tél: (450) 979-4373 Fax: (450) 979-4626 <a href="http://www.exmweb.com">www.exmweb.com</a>		Flatness Aplatissement Max 3.0mm Projection 
Customer Client	Date	
Drawn By Dessiné Par	BoxCad: BoxCad	Date 15-Apr-22
Material Matière	12 Ga Cold Rolled A1008 CS Type B (2.5mm)	
Color Couleur	Asa-61 Grey	Finish Fini Smooth
Description	Detail Rev.	
9500U2D 72" x 77.75" x 18" Assembly		
Part Number Numéro Pièce	Rev. 0	1 / 17

SEE BILL OF MATERIAL ON LAST PAGE

**9500U2D727818**

This drawing is confidential and must not be reproduced or used without the consent of EXM

Ce dessin est confidentiel et ne doit pas être reproduit ou utilisé sans le consentement de EXM

NOTE	
ITEM	DESCRIPTION
1	NEMA 12, 13 Enclosure (IP55)
2	C/W Standard ground studs on box and cover
3	C/W Standard door stiffener
4	C/W Special inner panel (Sold separately)
5	C/W Standard inner panel mounting studs
6	C/W Eyebolts sold separately (Installed by EXM)
7	C/W Struts installed (Included)

No.	Revisions	Date	By/Par

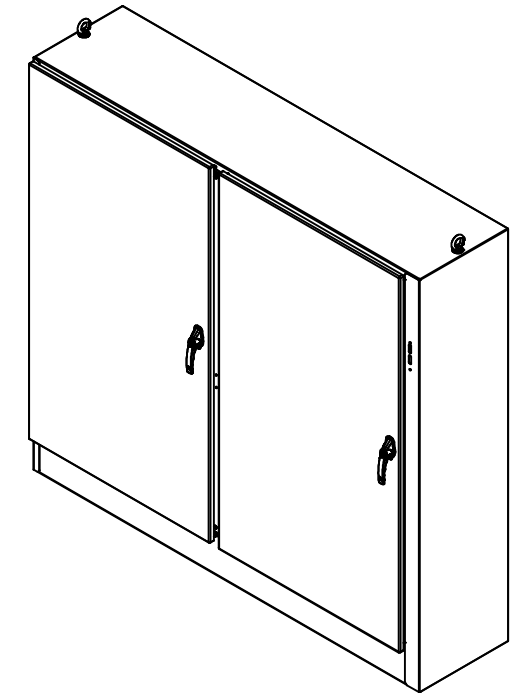

Isometric View

 Tél: (450) 979-4373  
 Fax: (450) 979-4626  
[www.exmweb.com](http://www.exmweb.com)

Flatness  
 Aplatissement  
 Max 3.0mm  
 Projection  

PACKING		
ITEM	QTY	DESCRIPTION
Cardboard sleeve	2	Top and Bottom
Cardboard strip	2	Between back of enclosure and inner panel
Plastic bag	1	To protect cover surface and inside gasket
Cardboard corner	4	To reinforced for the plastic strap tightening
Plastic strap - Black	2	To Squeeze the 2 cardboard sleeve together
Packaging label	3	White label with PN
Plastic strap- Green	2	To secure the enclosure to the wood pallet
Wood Pallet	1	2" deeper and 3" larger than enclosure size

1	880EB14	2	Eye Bolt M14 (Pack of 2)
1	9500U2D727818GP	0	9500U2D Gland Plate
1	880INT1	4	880 INT1 - Interlock Post Kit
10	STK-Q-07320	0	Flange Lock Nut M10
1	9500U2D727818IP	0	9500U2D 72" x 77.75" Inner Panel
10	STK-Q-07620	0	M10 Plastic Spacer 0.875"
8	STK-Q-04050-10	8	M6 x 10mm Hexagon Socket Head Machine Screw with Nyseal
1	9500U2D727818FD	0	9500U2D 72" x 77.75" Lock Door
1	9500U2D727818LD	0	9500U2D 72" x 77.75" Lock Door
1	9500U2D727818B	0	9500U2D 72" x 77.75" x 18" Body
Qty	Part Number	Rev	Description
Parts List			

Customer Client \_\_\_\_\_ Date \_\_\_\_\_

Drawn By Dessiné Par BoxCad: BoxCad Date 15-Apr-22

Material Matière 12 Ga Cold Rolled A1008 CS Type B (2.5mm)

Color Couleur Asa-61 Grey Finish Fini Smooth

Description 9500U2D 72" x 77.75" x 18" Assembly Detail Rev. \_\_\_\_\_

Part Number Numéro Pièce **9500U2D727818** Rev. **0** 2/17

This drawing is confidential and must not be reproduced or used without the consent of EXM

Ce dessin est confidentiel et ne doit pas être reproduit ou utilisé sans le consentement de EXM

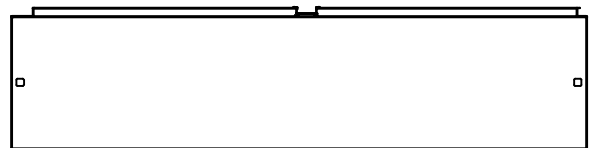

TOP

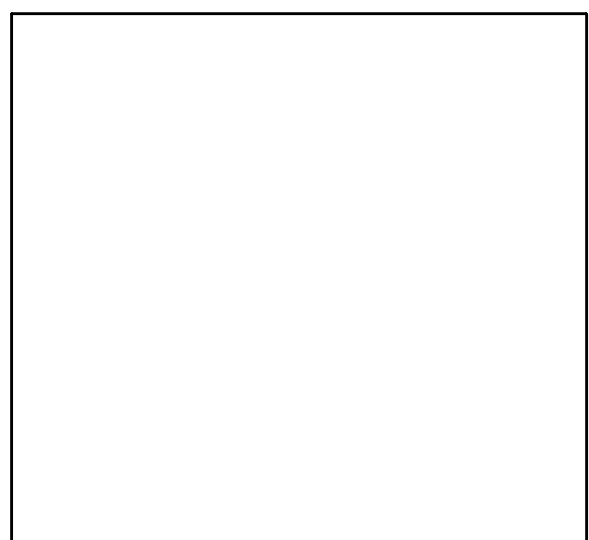

BACK

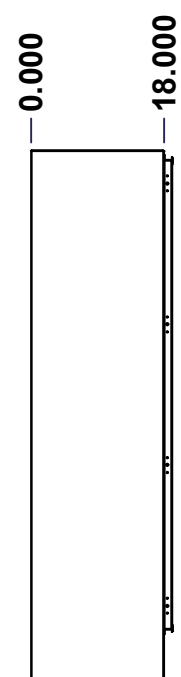

LEFT

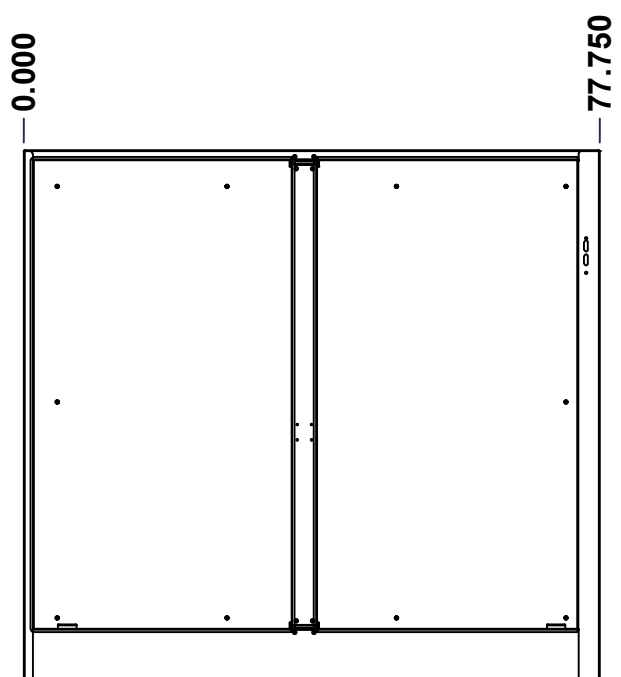

FRONT

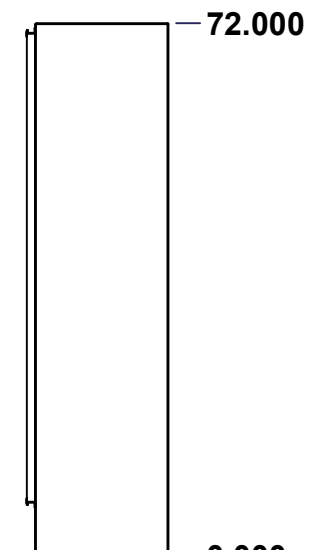

RIGHT

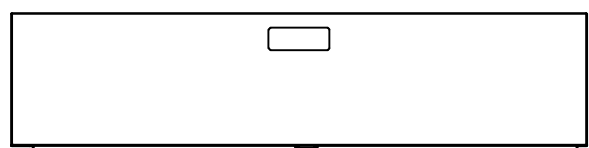

BOTTOM

No.	Revisions	Date	By/Par

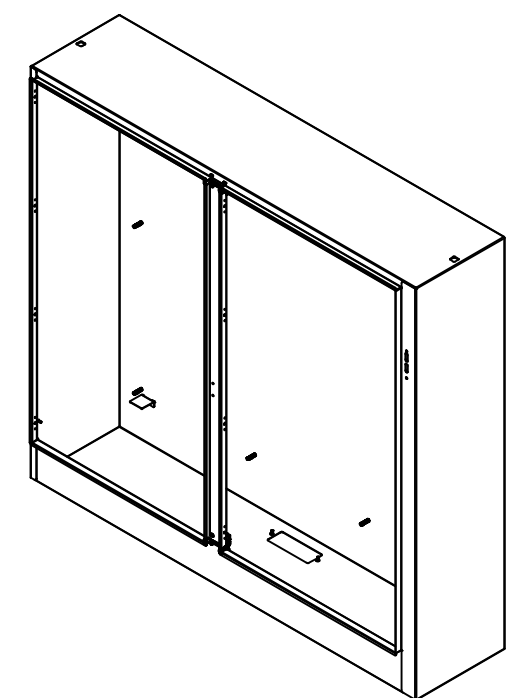

Isometric View



Tél: (450) 979-4373  
 Fax: (450) 979-4626  
[www.exmweb.com](http://www.exmweb.com)

Flatness  
Aplatissement  
Max 3.0mm  
Projection

Customer Client	Date
Drawn By Dessiné Par BoxCad: BoxCad	Date 15-Apr-22
Material Matière 12 Ga Cold Rolled A1008 CS Type B (2.5mm)	
Color Couleur Asa-61 Grey	Finish Fini Smooth
Description 9500U2D 72" x 77.75" x 18" Body	Detail Rev.
Part Number Numéro Pièce <b>9500U2D727818B</b>	Rev. 3 <b>0</b>

SEE BILL OF MATERIAL ON LAST PAGE

This drawing is confidential and must not be reproduced or used without the consent of EXM

Ce dessin est confidentiel et ne doit pas être reproduit ou utilisé sans le consentement de EXM

**STANDARD FEATURES ARE NOT LISTED IN THIS HOLE TABLE**

**HOLE TABLE - TOP VIEW (CUSTOM FEATURE ONLY)**

CUT-OUT	XDIM	YDIM	DESCRIPTION
1	19.438	14.000	Struts CR400 33.500" (Inside)
2	58.313	14.000	Struts CR400 33.500" (Inside)
3	19.438	14.929	STUDS M6 x 10mm (Inside)
4	36.304	14.000	STUDS M6 x 10mm (Inside)
5	58.313	14.929	STUDS M6 x 10mm (Inside)
6	75.179	14.000	STUDS M6 x 10mm (Inside)

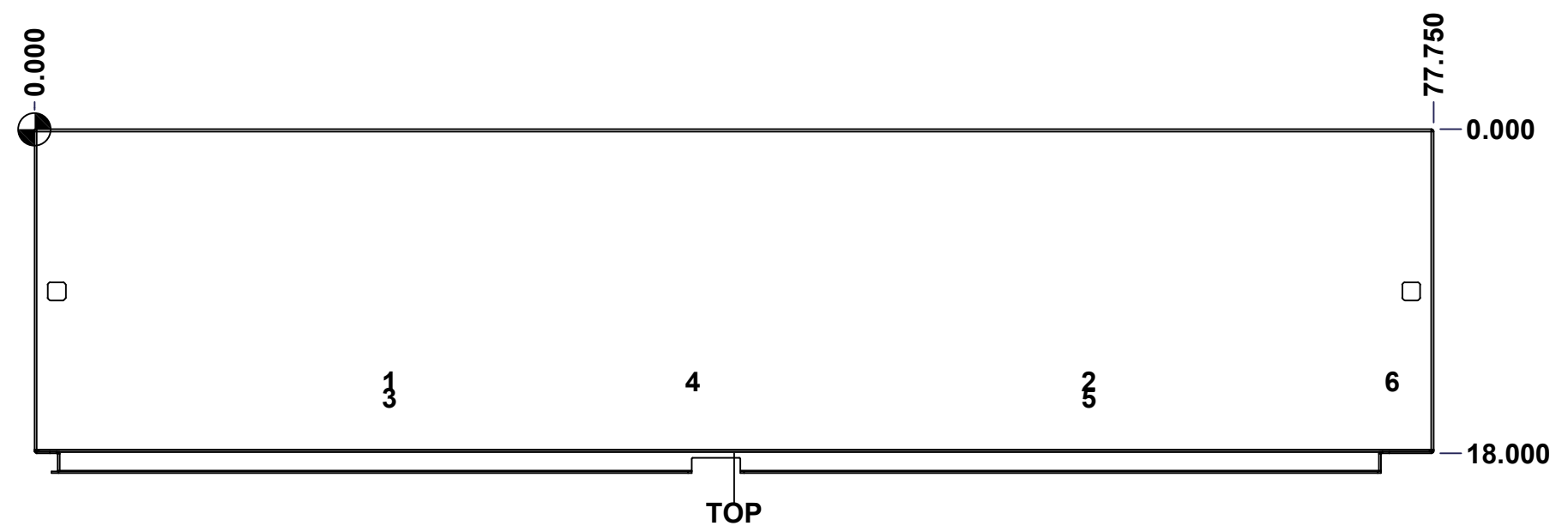

	Description	Status	
	9500U2D 72" x 77.75" x 18" Body	(NULL)	
	Part Number Numéro Pièce	Rev.	
	<b>9500U2D727818B</b>	<b>0</b>	4 17

This drawing is confidential and must not be reproduced or used without the consent of EXM

Ce dessin est confidentiel et ne doit pas être reproduit ou utilisé sans le consentement de EXM

<b>STANDARD FEATURES ARE NOT LISTED IN THIS HOLE TABLE</b>			
<b>HOLE TABLE - BOTTOM VIEW (CUSTOM FEATURE ONLY)</b>			
CUT-OUT	XDIM	YDIM	DESCRIPTION
1	34.250	3.500	GP STUD M6 x 16mm (Inside)
2	43.500	3.500	GP STUD M6 x 16mm (Inside)

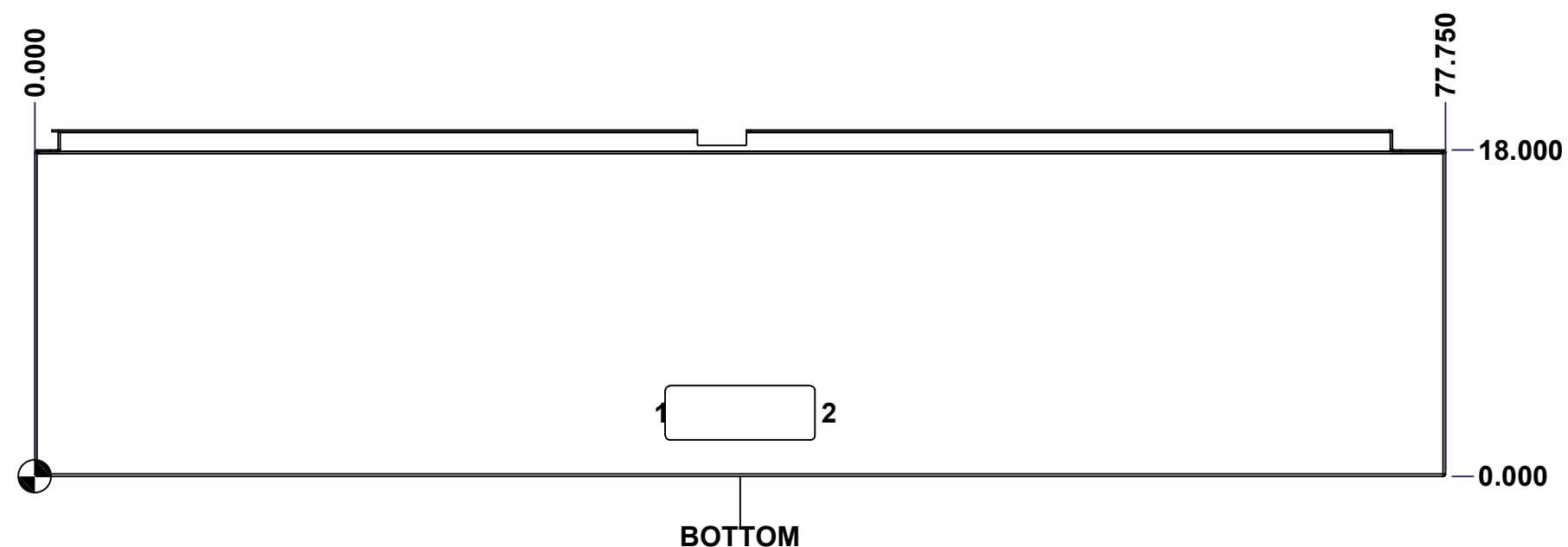

	Description	Status	
	9500U2D 72" x 77.75" x 18" Body	(NULL)	
	Part Number Numéro Pièce	Rev.	5
	<b>9500U2D727818B</b>	<b>0</b>	17

This drawing is confidential and must not be reproduced or used without the consent of EXM

Ce dessin est confidentiel et ne doit pas être reproduit ou utilisé sans le consentement de EXM

<b>STANDARD FEATURES ARE NOT LISTED IN THIS HOLE TABLE</b>			
<b>HOLE TABLE - LEFT VIEW (CUSTOM FEATURE ONLY)</b>			
CUT-OUT	XDIM	YDIM	DESCRIPTION
1	16.500	9.375	GND STUD M6 x 16mm (Inside)

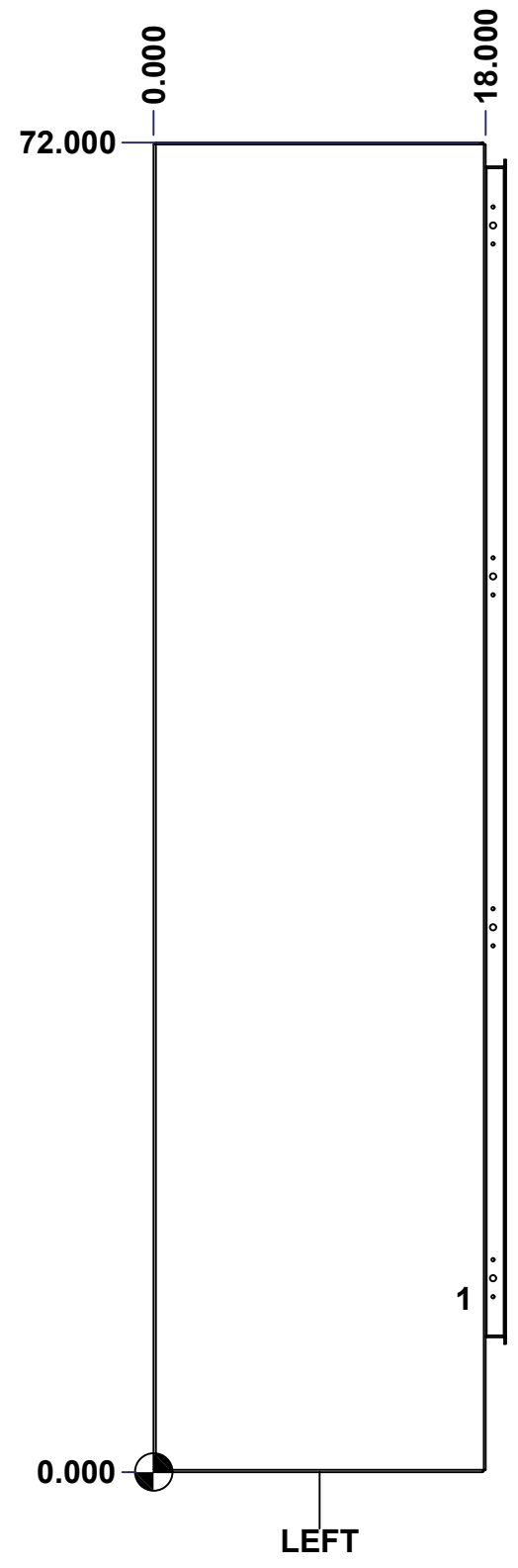

	Description	Status
	9500U2D 72" x 77.75" x 18" Body	(NULL)
	Part Number Numéro Pièce	Rev.
	<b>9500U2D727818B</b>	<b>0</b>
		6
		17

This drawing is confidential and must not be reproduced or used without the consent of EXM

Ce dessin est confidentiel et ne doit pas être reproduit ou utilisé sans le consentement de EXM

**STANDARD FEATURES ARE NOT LISTED IN THIS HOLE TABLE**

**HOLE TABLE - BACK VIEW (CUSTOM FEATURE ONLY)**

CUT-OUT	XDIM	YDIM	DESCRIPTION
1	4.550	8.875	IP STUD M10 x 40mm (Inside)
2	73.200	8.875	IP STUD M10 x 40mm (Inside)
3	4.550	67.125	IP STUD M10 x 40mm (Inside)
4	73.200	67.125	IP STUD M10 x 40mm (Inside)
5	4.550	38.000	IP STUD M10 x 40mm (Inside)
6	73.200	38.000	IP STUD M10 x 40mm (Inside)
7	27.433	8.875	IP STUD M10 x 40mm (Inside)
8	50.317	8.875	IP STUD M10 x 40mm (Inside)
9	27.433	67.125	IP STUD M10 x 40mm (Inside)
10	50.317	67.125	IP STUD M10 x 40mm (Inside)
-----	-----	-----	-----
11	5.875	7.500	IP SUPPORT ANGLE (Inside)
12	71.875	7.500	IP SUPPORT ANGLE (Inside)

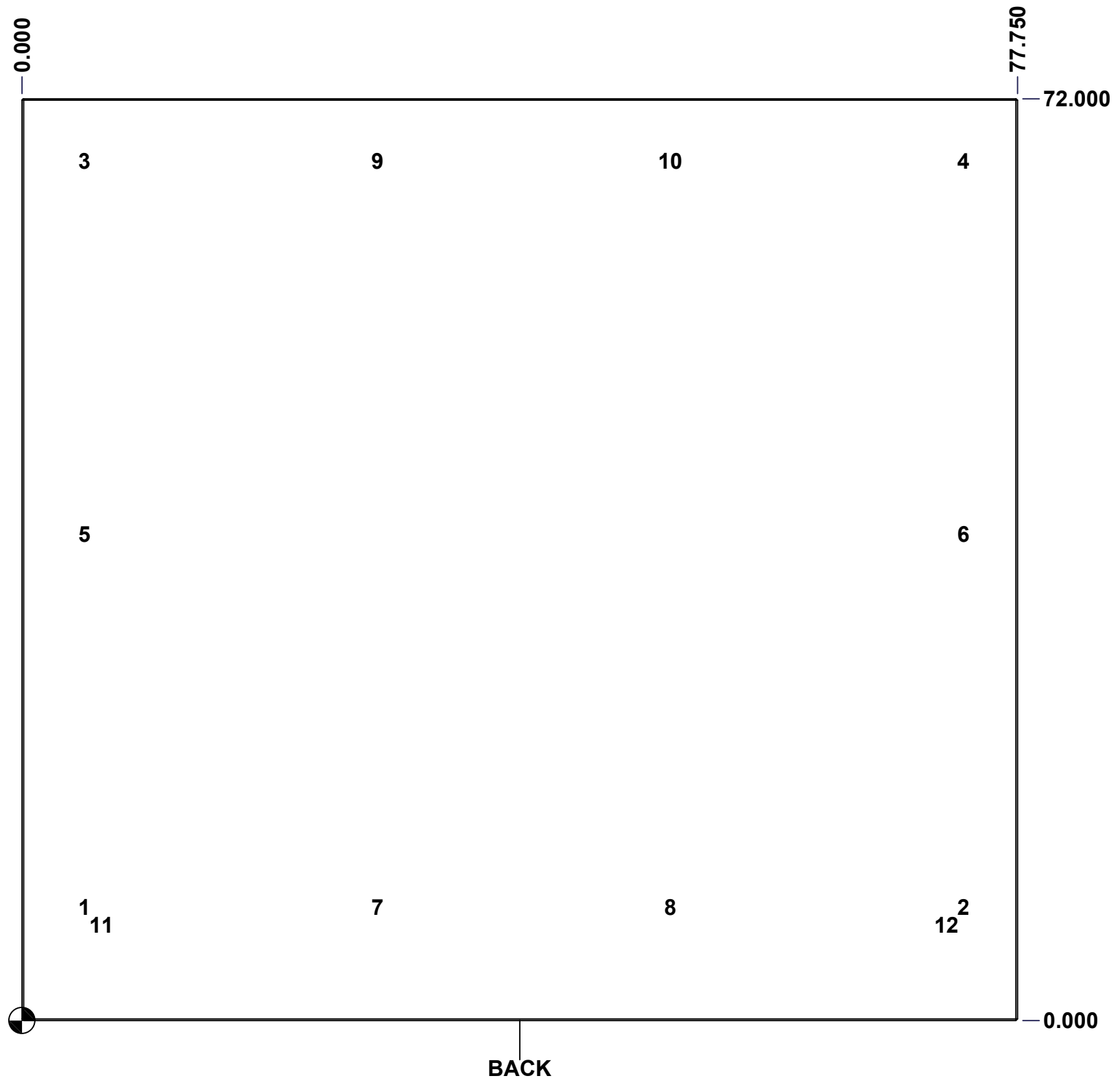

	Description	Status
	9500U2D 72" x 77.75" x 18" Body	(NULL)
Part Number Numéro Pièce <b>9500U2D727818B</b>	Rev.	7
	<b>0</b>	17

This drawing is confidential and must not be reproduced or used without the consent of EXM

Ce dessin est confidentiel et ne doit pas être reproduit ou utilisé sans le consentement de EXM

**STANDARD FEATURES ARE NOT LISTED IN THIS HOLE TABLE**

**HOLE TABLE - BACK VIEW (CUSTOM FEATURE ONLY)**

CUT-OUT	XDIM	YDIM	DESCRIPTION
1	1.732	3.648	GND STUD M6 x 16mm (Inside)
-----			
2	0.748	25.138	PEM FH-M6-15ZI (Inside)
3	0.748	27.264	PEM FH-M6-15ZI (Inside)
4	2.717	25.138	PEM FH-M6-15ZI (Inside)
5	2.717	27.264	PEM FH-M6-15ZI (Inside)

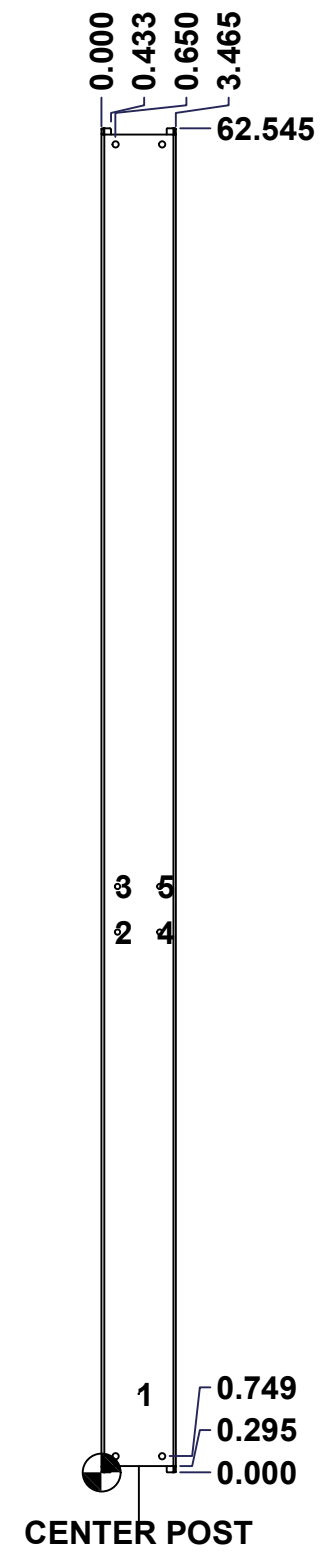

	Description	Status	
	9500U2D 72" x 77.75" x 18" Body	(NULL)	
	Part Number	Rev.	8
	Numéro Pièce	<b>0</b>	17
		<b>9500U2D727818B</b>	

This drawing is confidential and must not be reproduced or used without the consent of EXM

Ce dessin est confidentiel et ne doit pas être reproduit ou utilisé sans le consentement de EXM

No.	Revisions	Date	By/Par

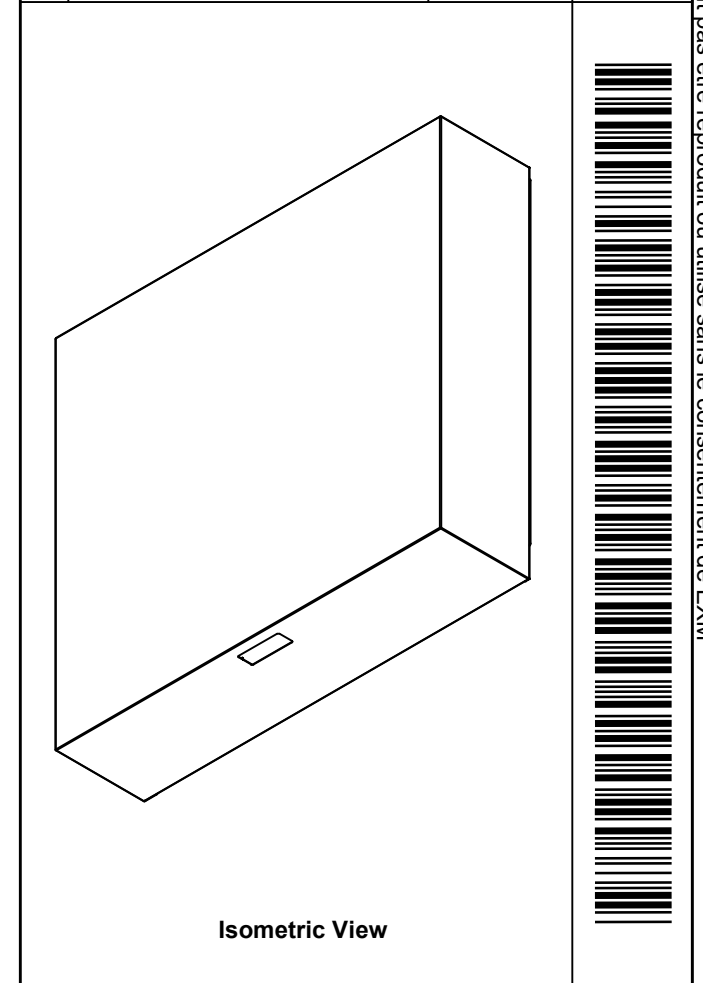

4	STK-PEM-FH-M6-15ZI	0	PEM Self-Clinching Stud M6 x 15.0mm
4	STK-Q-16030	0	Stud M6 x 10mm Steel
2	9500U2D727818BPA-P	0	9500U2D Inner Panel Support Angle
1	STK-P-02400S	0	Powder Paint (Asa-61 Grey / Smooth)
2	STK-Q-74900	0	Eyebolt Lifting Angle (8.750")
1	STK-A-75454	3	Center Post - Sealing Block with Latch Assembly (Large)
1	9500U2D727818CP-P	0	9500U2D 72" Center Post Part
10	STK-Q-16100	0	Stud M10 x 40mm Steel
1	9500U2D727818B-P	0	9500U2D 72" x 77.75" Body Part
2	9500U2D727818_CR400 MS_33.5	0	Commercial Roll Mild Steel (33.5in long)
4	STK-Q-16080	0	Ground Stud M6 x 16mm Steel

Qty	Part Number	Rev	Description
Parts List			

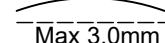
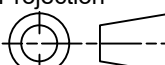
 Tél: (450) 979-4373 Fax: (450) 979-4626 <a href="http://www.exmweb.com">www.exmweb.com</a>		Flatness Aplatissement  Max 3.0mm
Projection 		Date 15-Apr-22
Customer Client	BoxCad: BoxCad	Date
Drawn By Dessiné Par	Material Matière	Detail Rev.
12 Ga Cold Rolled A1008 CS Type B (2.5mm)	9500U2D 72" x 77.75" x 18" Body	9
Color Couleur	Finish Fini	0
Asa-61 Grey	Smooth	17
Part Number Numéro Pièce <b>9500U2D727818B</b>		Rev.

This drawing is confidential and must not be reproduced or used without the consent of EXM

Ce dessin est confidentiel et ne doit pas être reproduit ou utilisé sans le consentement de EXM

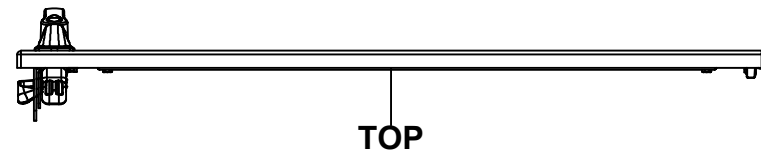

TOP

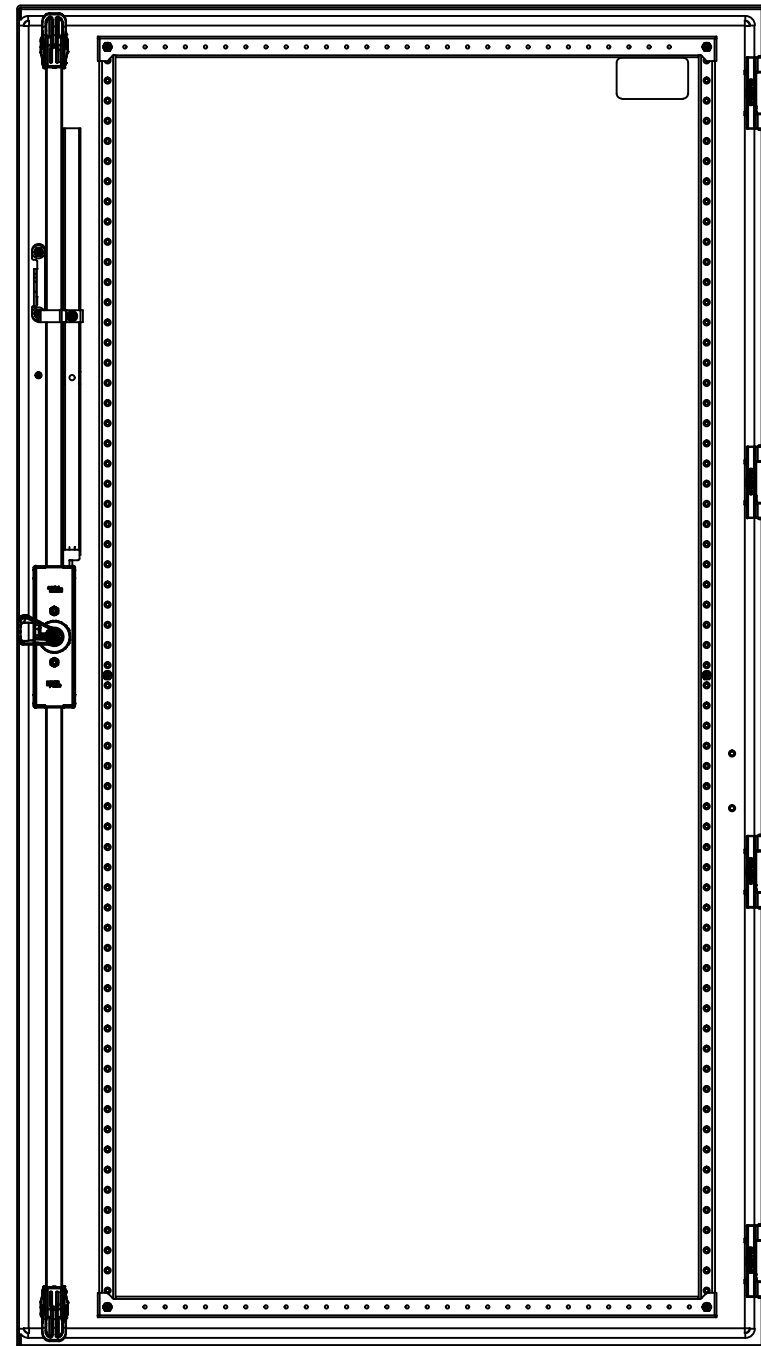

BACK



BOTTOM

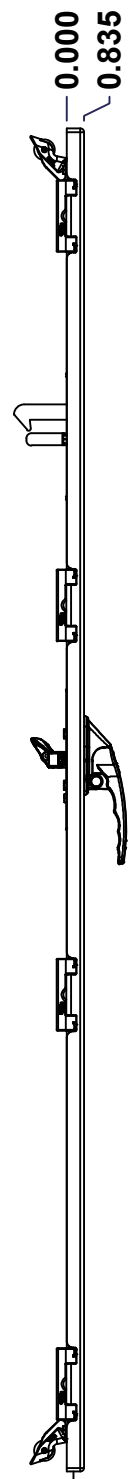

LEFT

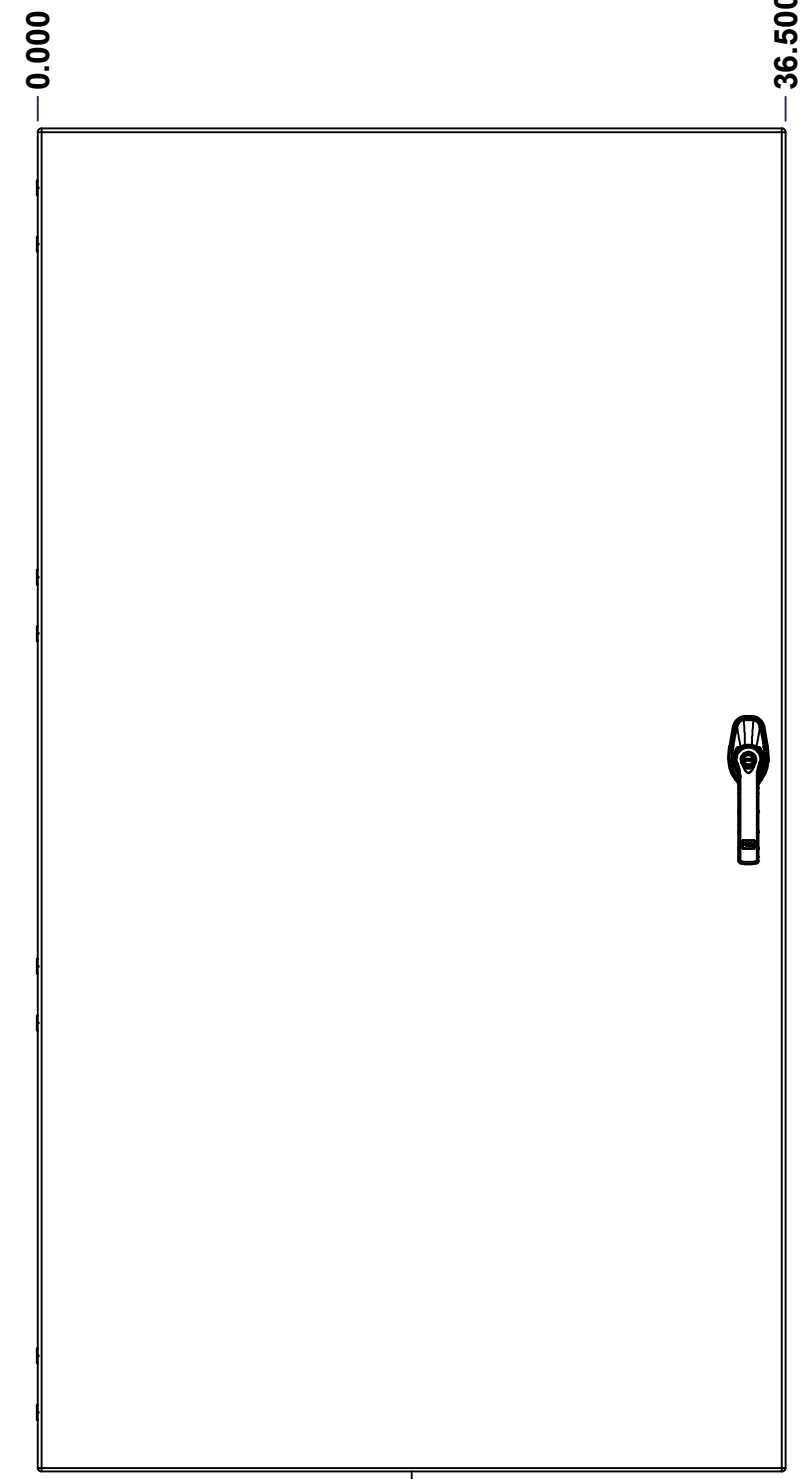

FRONT

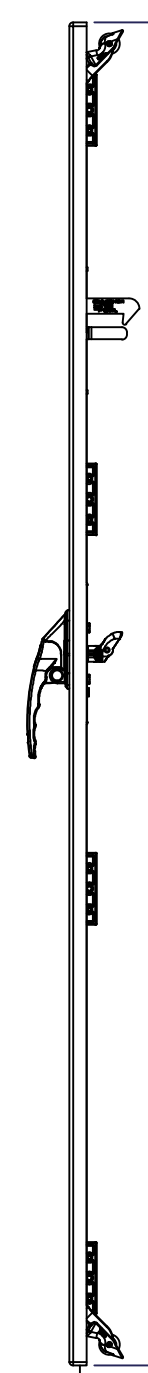

RIGHT

0.000  
0.835

0.000

36.500

65.549

0.000

No.	Revisions	Date	By/Par

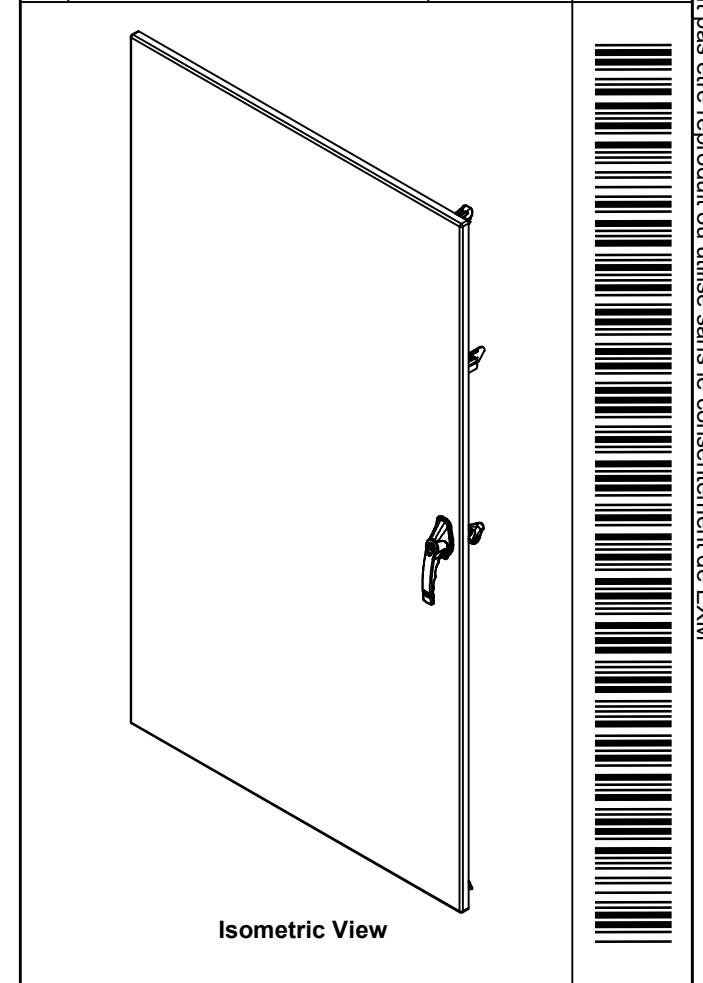

Isometric View

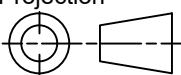
 Tél: (450) 979-4373 Fax: (450) 979-4626 <a href="http://www.exmweb.com">www.exmweb.com</a>		Flatness Aplatissement Max 3.0mm Projection 
Customer Client		Date
Drawn By Dessiné Par	BoxCad: BoxCad	Date 15-Apr-22
Material Matière	12 Ga Cold Rolled A1008 CS Type B (2.5mm)	
Color Couleur	Asa-61 Grey	Finish Fini Smooth
Description	Detail Rev.	
9500U2D 72" x 77.75" Lock Door		
Part Number Numéro Pièce	Rev.	10
9500U2D727818LD	0	17

SEE BILL OF MATERIAL ON LAST PAGE

This drawing is confidential and must not be reproduced or used without the consent of EXM

Ce dessin est confidentiel et ne doit pas être reproduit ou utilisé sans le consentement de EXM

STANDARD FEATURES ARE NOT LISTED IN THIS HOLE TABLE			
HOLE TABLE - FRONT VIEW (CUSTOM FEATURE ONLY)			
CUT-OUT	XDIM	YDIM	DESCRIPTION
1	35.455	53.511	STUD M6 x 18mm (Inside)
2	35.455	50.511	STUD M6 x 18mm (Inside)
3	35.455	47.511	STUD M6 x 18mm (Inside)
4	34.678	6.179	LARGE CBAR GUIDE (Inside)
5	34.678	59.370	LARGE CBAR GUIDE (Inside)
6	33.822	57.870	LARGE CBAR GUIDE (Inside)
7	2.847	2.028	STUD M6 x 18mm (Inside)
8	2.847	32.854	STUD M6 x 18mm (Inside)
9	2.847	63.521	STUD M6 x 18mm (Inside)
10	32.098	2.028	STUD M6 x 18mm (Inside)
11	32.098	32.854	STUD M6 x 18mm (Inside)
12	32.098	63.521	STUD M6 x 18mm (Inside)
-----			
13	34.688	34.743	HANDLE 885 ESL2A-APHD @ 0.0°
14	1.610	26.363	STUDS M6 x 18mm (Inside)
15	1.610	29.041	STUDS M6 x 18mm (Inside)

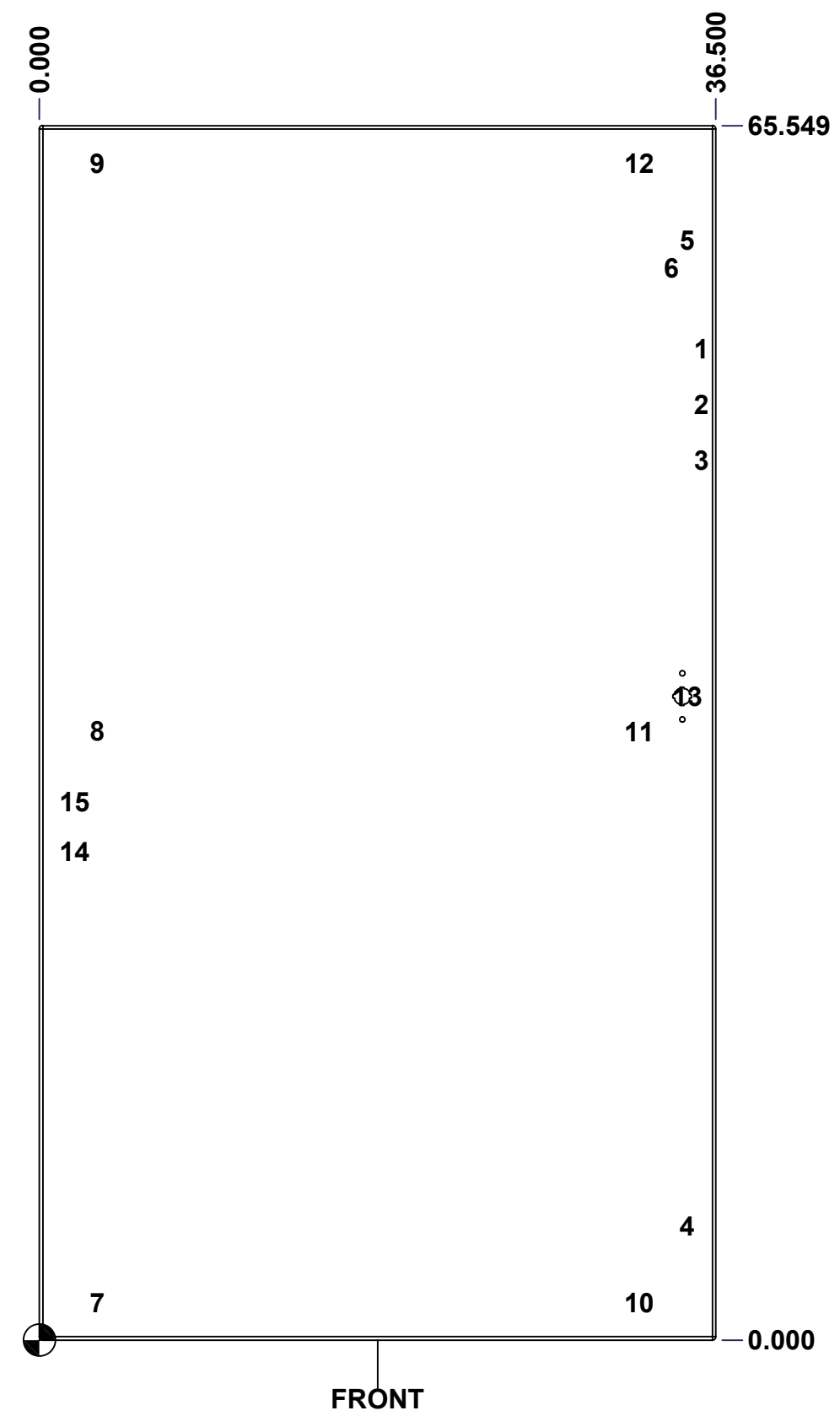

FRONT

	Description	Status
	9500U2D 72" x 77.75" Lock Door	(NULL)
	Part Number Numéro Pièce	Rev.
	<b>9500U2D727818LD</b>	<b>0</b>
		11
		17

This drawing is confidential and must not be reproduced or used without the consent of EXM

Ce dessin est confidentiel et ne doit pas être reproduit ou utilisé sans le consentement de EXM

No.	Revisions	Date	By/Par

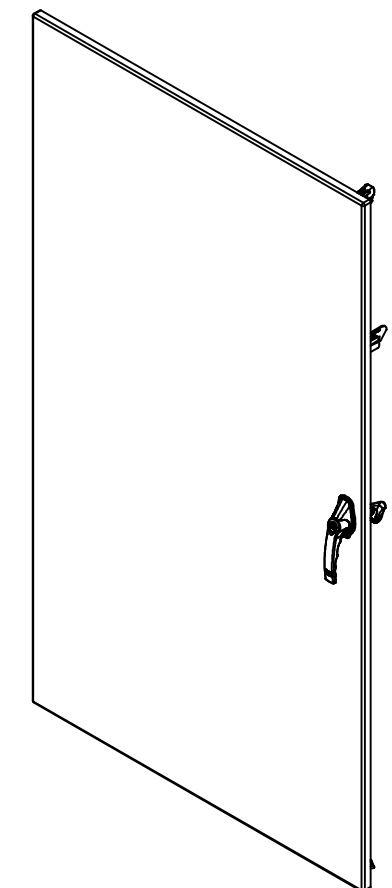

Isometric View



 Tél: (450) 979-4373  
 Fax: (450) 979-4626  
[www.exmweb.com](http://www.exmweb.com)

Flatness / Aplatissement: Max 3.0mm  
 Projection: 

1	STK-K-09572	0	9500 UxD 72" Locking Mechanism Kit
2	STK-Q-16050	1	Stud M6 x 18mm Steel
1	885ESL2A-APHD	1	885 ESL2A-APHD - Zinc Die Cast L-Handle Padlockable Assy - Slot Cylinder
1	STK-P-02400S	0	Powder Paint (Asa-61 Grey / Smooth)
1	STK-S-00100	0	3.5" x 2" Silver Milar Flexcon Sticker
1	9500U2D727818DS1	0	9500U2D 72" x 77.75" Door Stiffener
9	STK-Q-16055	1	M6 x 18mm Stud (No Paint Cap Required)
3	STK-Q-16410	0	Guide Stud - Largel (No Paint Cap Required)
4	STK-K-09860	7	Cabinet Hinge with Captive Pins
1	9500U2D727818LDG	0	9500U2D 72" x 77.75" Lock Door Gasket
1	9500U2D727818LD-P	0	9500U2D 72" x 77.75" Lock Door Part

Customer / Client	Date
Drawn By / Dessiné Par: BoxCad: BoxCad	Date: 15-Apr-22
Material / Matière: 12 Ga Cold Rolled A1008 CS Type B (2.5mm)	
Color / Couleur: Asa-61 Grey	Finish / Fini: Smooth
Description: 9500U2D 72" x 77.75" Lock Door	Detail Rev.
Part Number / Numéro Pièce: <b>9500U2D727818LD</b>	Rev. 0

QTY	Part Number	Rev	Description
Parts List			

This drawing is confidential and must not be reproduced or used without the consent of EXM

Ce dessin est confidentiel et ne doit pas être reproduit ou utilisé sans le consentement de EXM

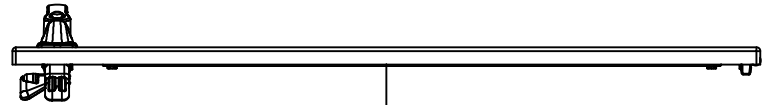

TOP

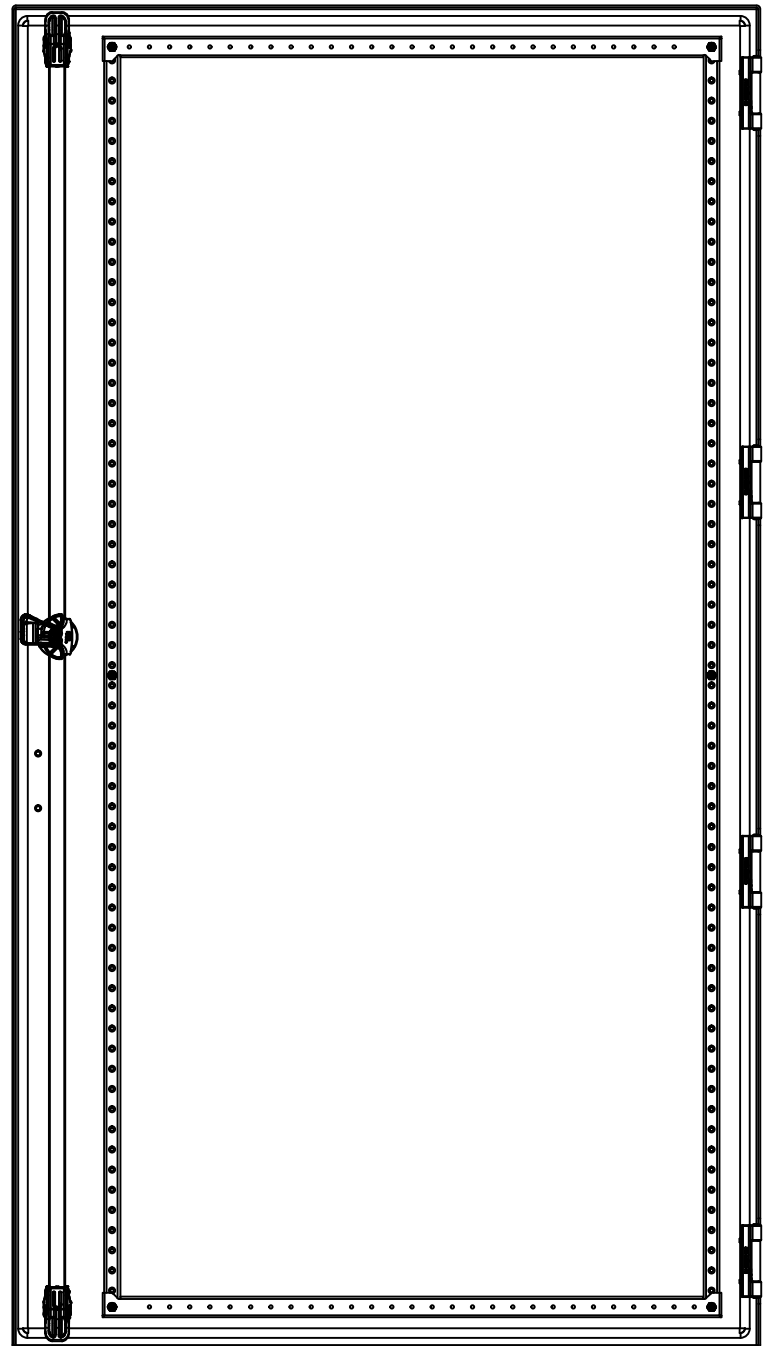

BACK



BOTTOM

0.000  
0.835

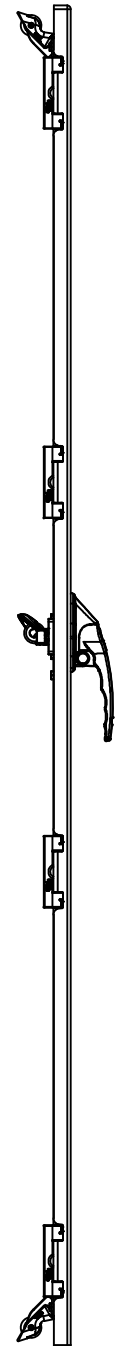

LEFT

0.000

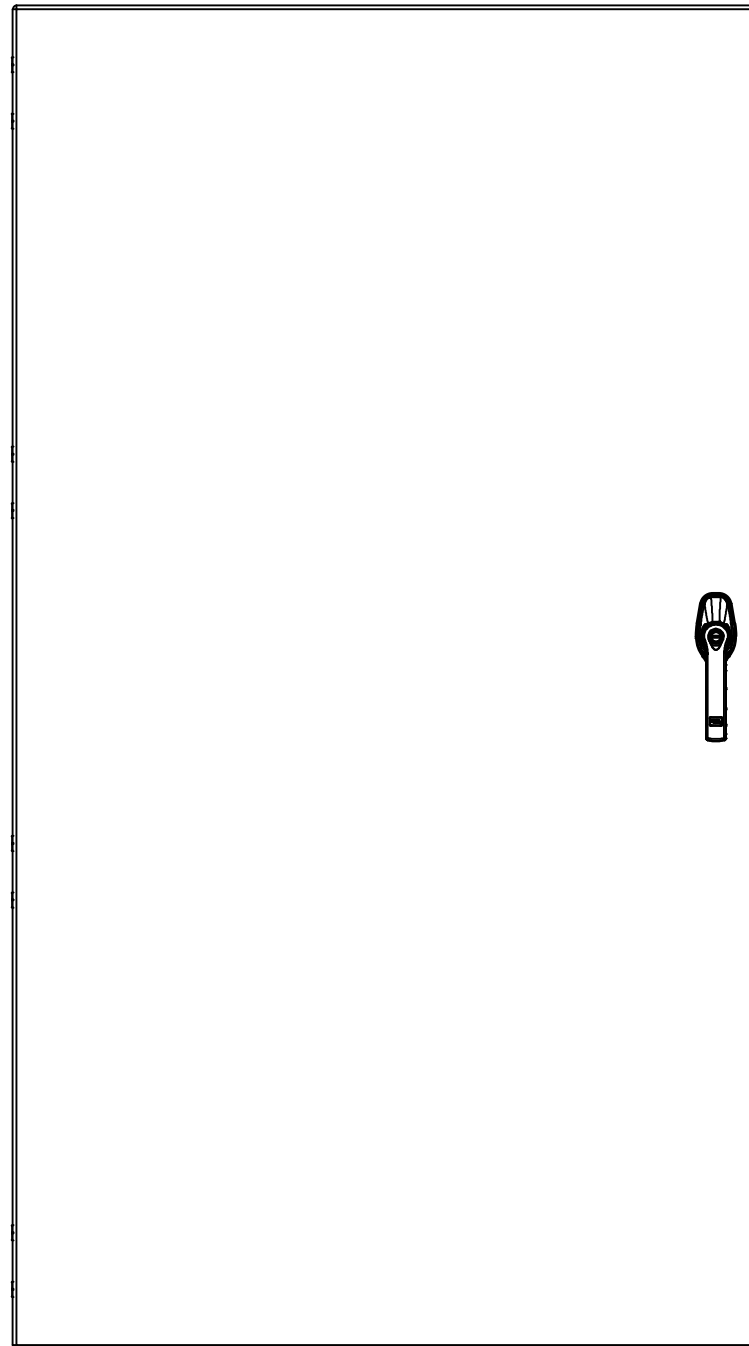

FRONT

36.500

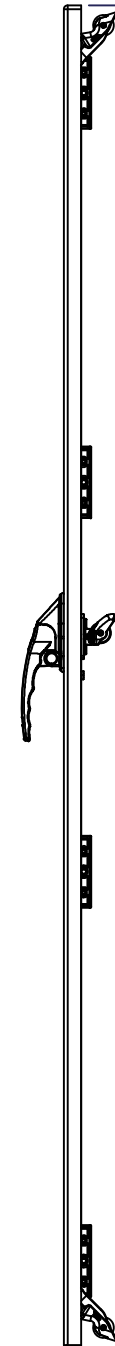

RIGHT

65.549

0.000

No.	Revisions	Date	By/Par

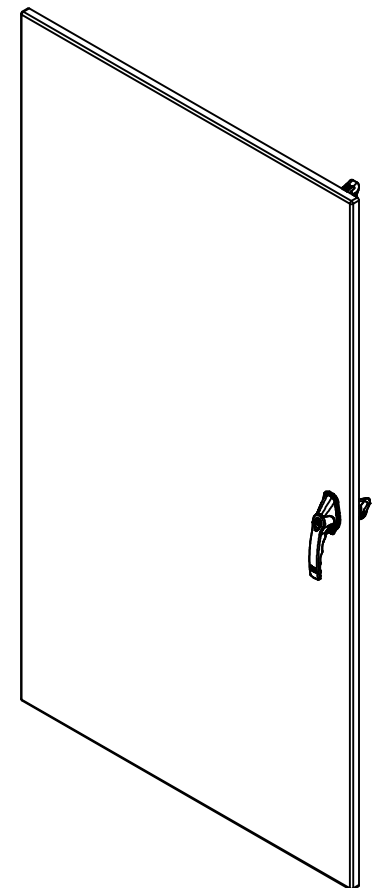

Isometric View



Tél: (450) 979-4373  
Fax: (450) 979-4626  
[www.exmweb.com](http://www.exmweb.com)

Flatness  
Aplatissement

Max 3.0mm

Projection

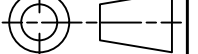

Customer Client	Date
Drawn By Dessiné Par BoxCad: BoxCad	Date 15-Apr-22
Material Matière 12 Ga Cold Rolled A1008 CS Type B (2.5mm)	
Color Couleur Asa-61 Grey	Finish Fini Smooth

Description	Detail Rev.
9500U2D 72" x 77.75" Lock Door	

Part Number Numéro Pièce	Rev.	13
<b>9500U2D727818FD</b>	<b>0</b>	17

SEE BILL OF MATERIAL ON LAST PAGE

This drawing is confidential and must not be reproduced or used without the consent of EXM

Ce dessin est confidentiel et ne doit pas être reproduit ou utilisé sans le consentement de EXM

**STANDARD FEATURES ARE NOT LISTED IN THIS HOLE TABLE**

**HOLE TABLE - FRONT VIEW (CUSTOM FEATURE ONLY)**

CUT-OUT	XDIM	YDIM	DESCRIPTION
1	34.313	6.118	LARGE CBAR GUIDE (Inside)
2	34.313	59.431	LARGE CBAR GUIDE (Inside)
3	2.375	2.028	STUD M6 x 18mm (Inside)
4	2.375	32.854	STUD M6 x 18mm (Inside)
5	2.375	63.521	STUD M6 x 18mm (Inside)
6	31.626	2.028	STUD M6 x 18mm (Inside)
7	31.626	32.854	STUD M6 x 18mm (Inside)
8	31.626	63.521	STUD M6 x 18mm (Inside)
-----			
9	34.312	34.743	HANDLE 885 ESL2A-APHD @ 0.0°
10	35.247	26.363	STUDS M6 x 18mm (Inside)
11	35.247	29.041	STUDS M6 x 18mm (Inside)

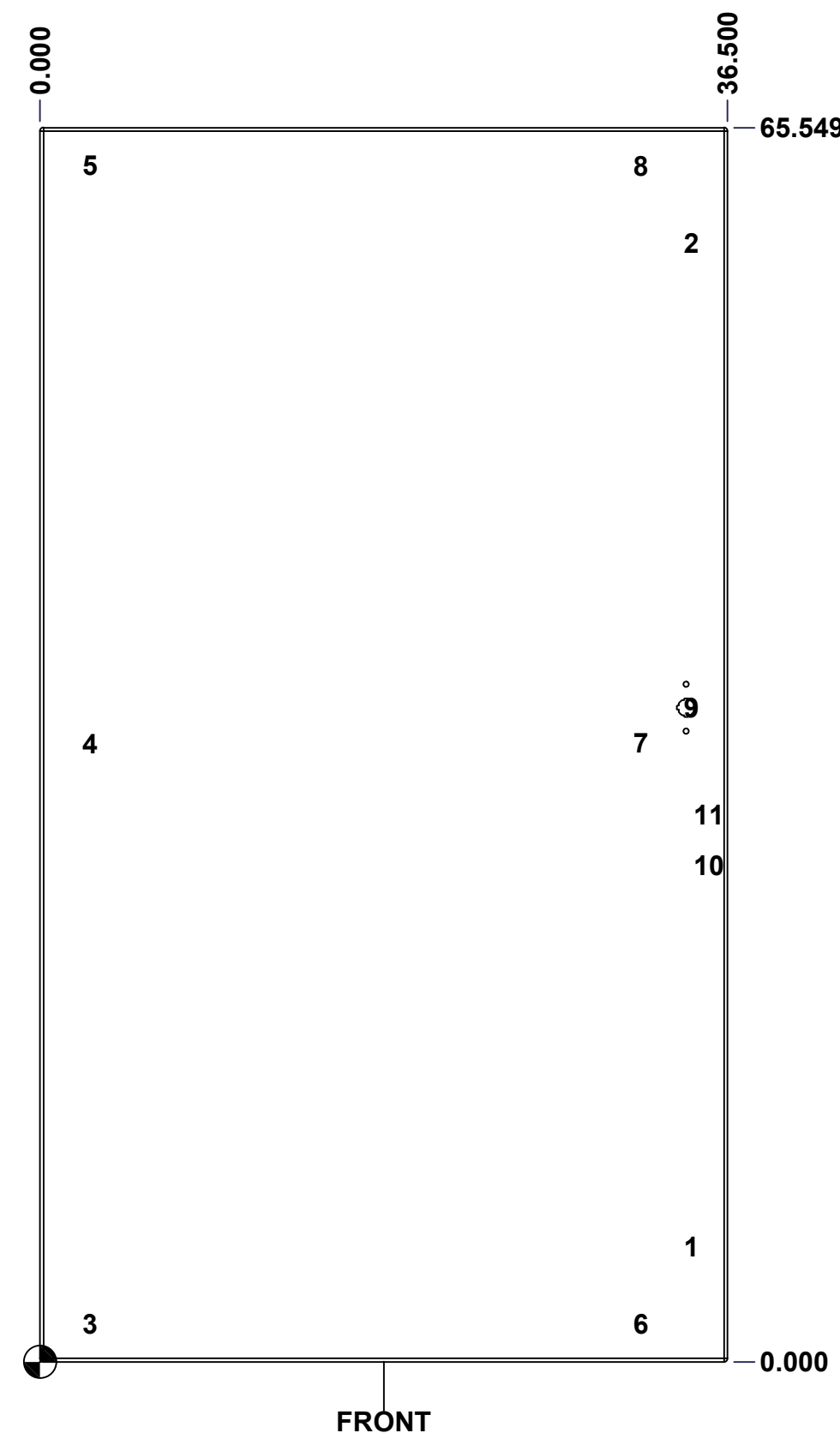

	Description	Status
	9500U2D 72" x 77.75" Lock Door	(NULL)
	Part Number Numéro Pièce	Rev.
	<b>9500U2D727818FD</b>	<b>0</b> / 14
		17

This drawing is confidential and must not be reproduced or used without the consent of EXM

Ce dessin est confidentiel et ne doit pas être reproduit ou utilisé sans le consentement de EXM

No.	Revisions	Date	By/Par

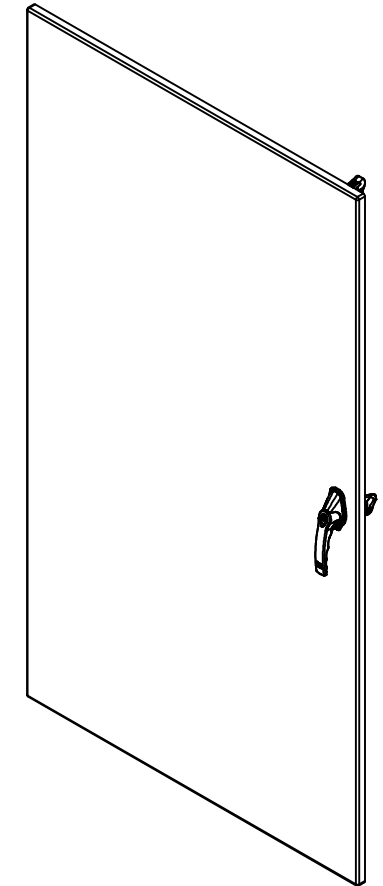

Isometric View



2	STK-Q-16050	1	Stud M6 x 18mm Steel
2	STK-Q-07220	1	M6 Nylon Insert Lock Nut
1	STK-Q-47562	0	9500 Lower Closing Bar 72" (cam)
2	STK-A-90025	3	9500 - Cabinet Closing Bar End (Large)
1	STK-Q-47552	0	9500 Upper Closing Bar 72" (cam)
1	STK-Q-90051	3	5412 ES - Handle Cam Spacer
1	STK-A-50538	3	9500 Handle Cam Assembly (Right Side, Grip 36mm)
1	885ESL2A-APHD	1	885 ESL2A-APHD - Zinc Die Cast L-Handle Padlockable Assy - Slot Cylinder
1	STK-P-02400S	0	Powder Paint (Asa-61 Grey / Smooth)
1	9500U2D727818DS1	0	9500U2D 72" x 77.75" Door Stiffener
6	STK-Q-16055	1	M6 x 18mm Stud (No Paint Cap Required)
2	STK-Q-16410	0	Guide Stud - Largel (No Paint Cap Required)
4	STK-K-09860	7	Cabinet Hinge with Captive Pins
1	9500U2D727818FDG	0	9500U2D 72" x 77.75" Flange Door Gasket
1	9500U2D727818FD-P	0	9500U2D 72" x 77.75" Lock Door Part

QTY	Part Number	Rev	Description
Parts List			

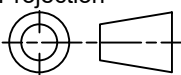
 Tél: (450) 979-4373 Fax: (450) 979-4626 <a href="http://www.exmweb.com">www.exmweb.com</a>	Flatness Aplatissement	Max 3.0mm
	Projection	
Customer Client	Date	
Drawn By Dessiné Par	BoxCad: BoxCad	Date 15-Apr-22
Material Matière	12 Ga Cold Rolled A1008 CS Type B (2.5mm)	
Color Couleur	Asa-61 Grey	Finish Fini Smooth
Description	9500U2D 72" x 77.75" Lock Door	
Part Number Numéro Pièce	Rev. 0	15 17
<b>9500U2D727818FD</b>		

This drawing is confidential and must not be reproduced or used without the consent of EXM

Ce dessin est confidentiel et ne doit pas être reproduit ou utilisé sans le consentement de EXM

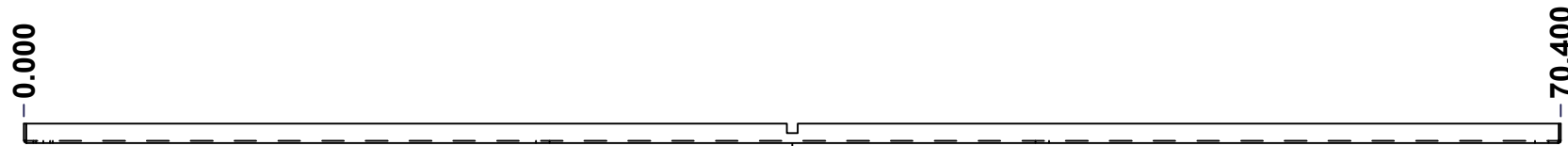

TOP



FRONT

60.000

0.000

RIGHT

No.	Revisions	Date	By/Par

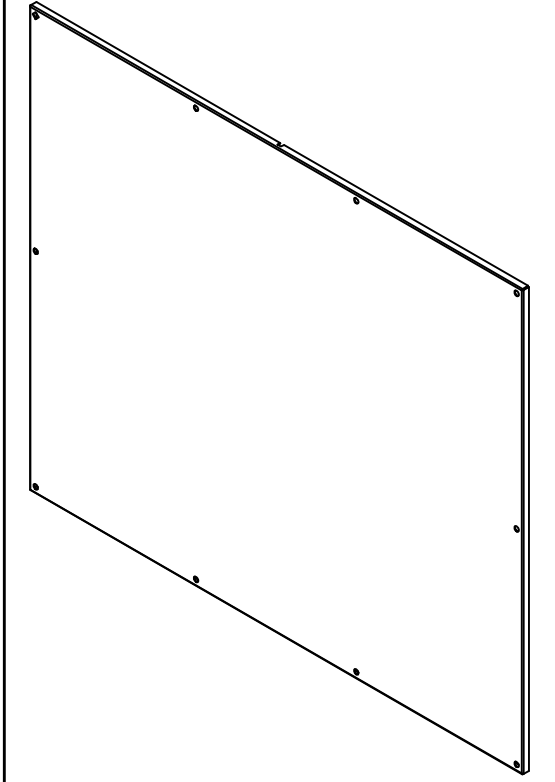

Isometric View



**EXM**  
exm

Tél: (450) 979-4373  
Fax: (450) 979-4626  
[www.exmweb.com](http://www.exmweb.com)

Flatness  
Aplatissement  
Max 3.0mm

Projection

Customer Client	Date
Drawn By Dessiné Par BoxCad: BoxCad	Date 15-Apr-22
Material Matière 12 Ga Cold Rolled A1008 CS Type B (2.5mm)	
Color Couleur White RAL9003	Finish Fini Smooth

Description 9500U2D 72" x 77.75" Inner Panel	Detail Rev.
---	-------------

Part Number Numéro Pièce <b>9500U2D727818IP</b>	Rev. <b>0</b>	16 17
---	------------------	----------

SEE BILL OF MATERIAL ON LAST PAGE

This drawing is confidential and must not be reproduced or used without the consent of EXM

Ce dessin est confidentiel et ne doit pas être reproduit ou utilisé sans le consentement de EXM

No.	Revisions	Date	By/Par

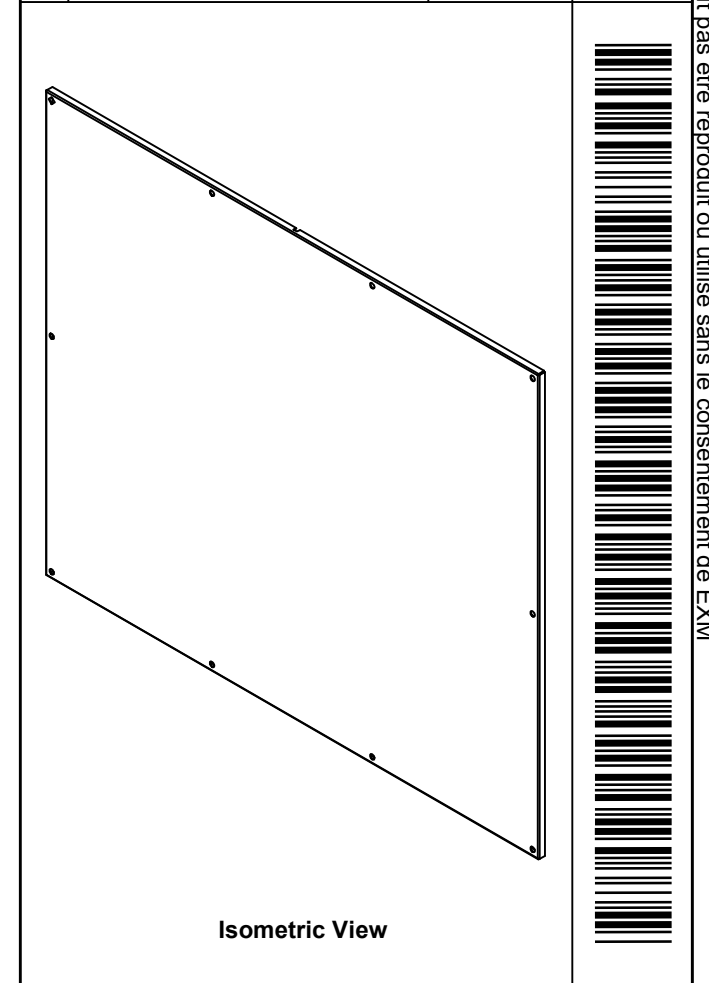

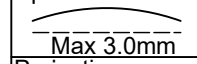
 Tél: (450) 979-4373 Fax: (450) 979-4626 <a href="http://www.exmweb.com">www.exmweb.com</a>		Flatness Aplatissement  Max 3.0mm
Customer Client		Date
Drawn By Dessiné Par BoxCad: BoxCad		Date 15-Apr-22
Material Matière 12 Ga Cold Rolled A1008 CS Type B (2.5mm)		
Color Couleur White RAL9003		Finish Fini Smooth
Description 9500U2D 72" x 77.75" Inner Panel		Detail Rev.
Part Number Numéro Pièce <b>9500U2D727818IP</b>		Rev. 17 <b>0</b>

Qty	Part Number	Rev	Description
1	STK-P-02401S	0	Powder Paint (White / Smooth)
1	9500U2D727818IP-P	0	9500U2D 72" x 77.75" Inner Panel Part
Parts List			