

This drawing is confidential and must not be reproduced or used without the consent of EXM

Ce dessin est confidentiel et ne doit pas être reproduit ou utilisé sans le consentement de EXM

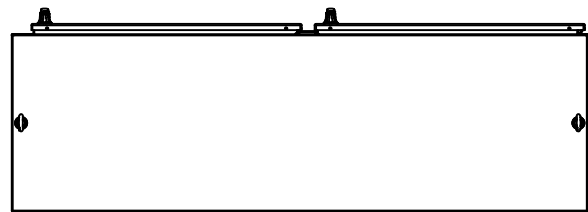

TOP

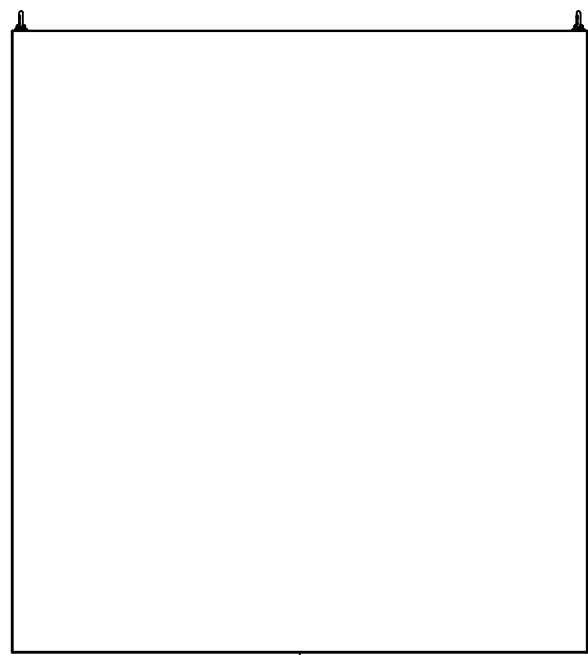

BACK

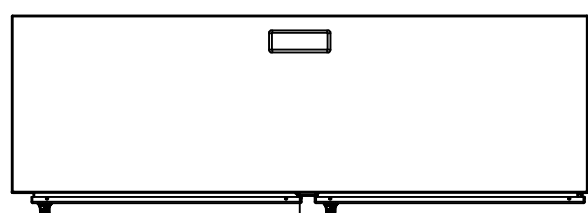

BOTTOM

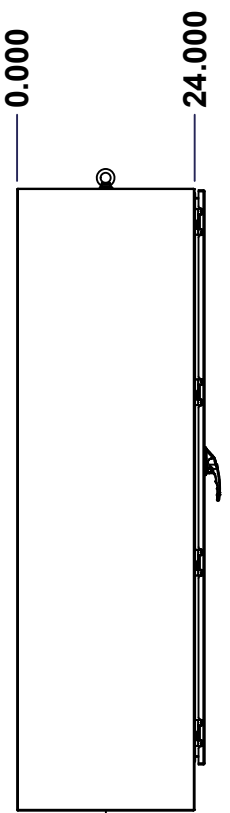

LEFT

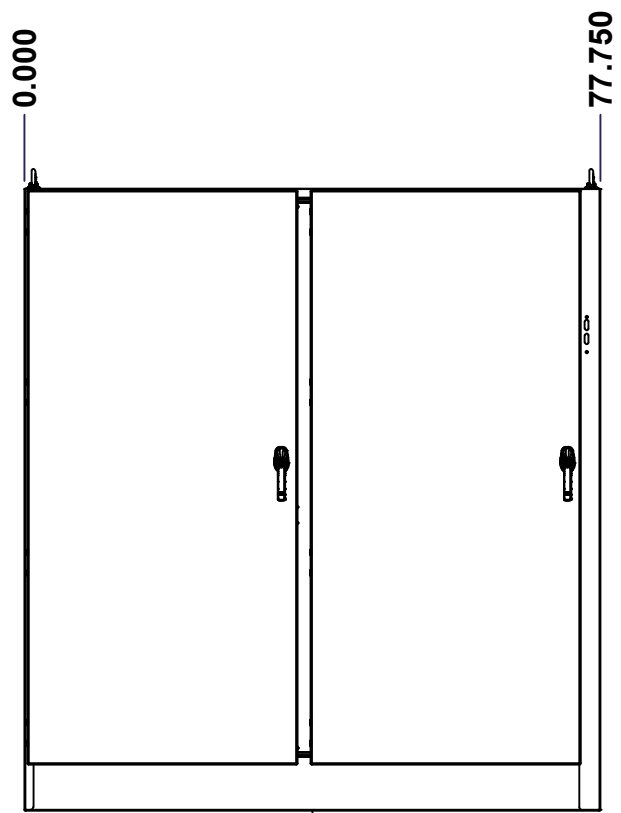

FRONT

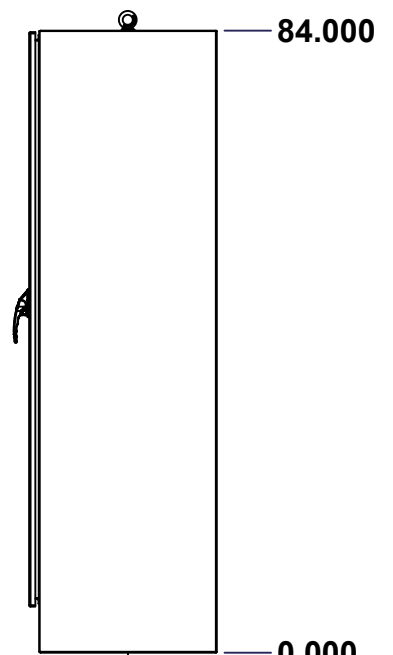

RIGHT

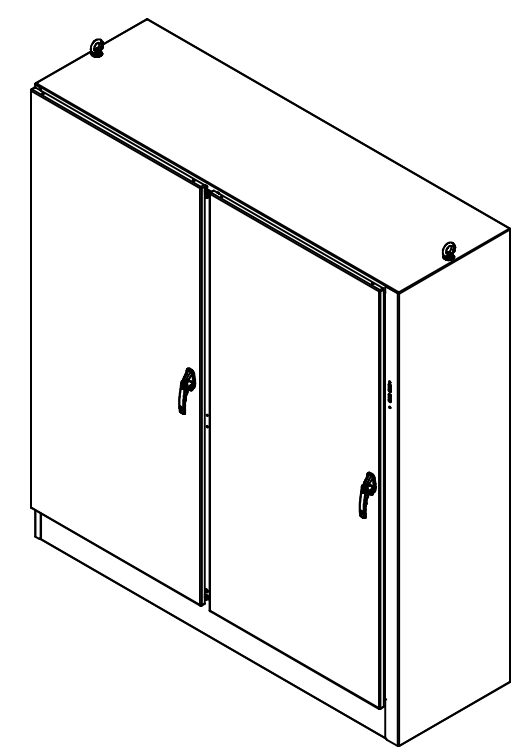

Isometric View

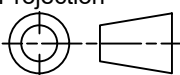

No.	Revisions	Date	By/Par

 Tél: (450) 979-4373 Fax: (450) 979-4626 www.exmweb.com		Flatness Aplatissement Max 3.0mm Projection 
Customer Client	Date	
Drawn By Dessiné Par	BoxCad: BoxCad	Date 15-Apr-22
Material Matière	12 Ga Cold Rolled A1008 CS Type B (2.5mm)	
Color Couleur	Asa-61 Grey	Finish Fini Smooth
Description	Detail Rev.	
9500U2D 84" x 77.75" x 24" Assembly		
Part Number Numéro Pièce	Rev.	1
9500U2D847824	0	17

SEE BILL OF MATERIAL ON LAST PAGE

This drawing is confidential and must not be reproduced or used without the consent of EXM

Ce dessin est confidentiel et ne doit pas être reproduit ou utilisé sans le consentement de EXM

NOTE	
ITEM	DESCRIPTION
1	NEMA 12, 13 Enclosure (IP55)
2	C/W Standard ground studs on box and cover
3	C/W Standard door stiffener
4	C/W Special inner panel (Sold separately)
5	C/W Standard inner panel mounting studs
6	C/W Eyebolts sold separately (Installed by EXM)
7	C/W Struts installed (Included)

No.	Revisions	Date	By/Par

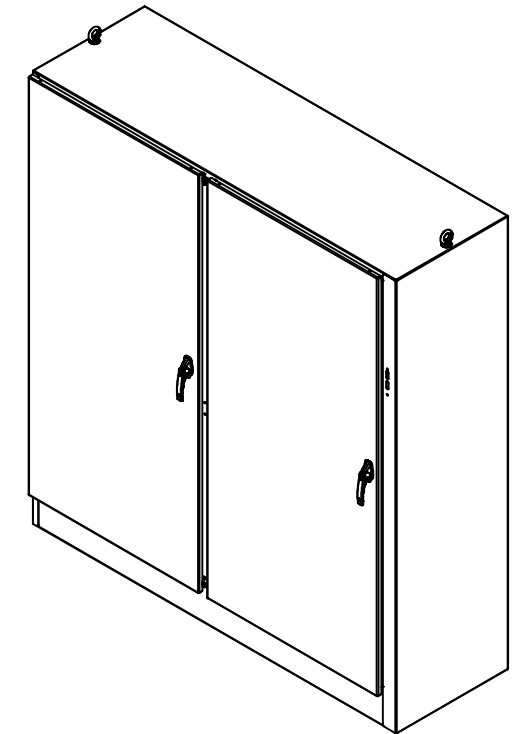

Isometric View

EXM
www.exm.com

Tél: (450) 979-4373
Fax: (450) 979-4626
www.exmweb.com

Flatness
Aplatissement
Max 3.0mm

Projection

PACKING		
ITEM	QTY	DESCRIPTION
Cardboard sleeve	2	Top and Bottom
Cardboard strip	2	Between back of enclosure and inner panel
Plastic bag	1	To protect cover surface and inside gasket
Cardboard corner	4	To reinforced for the plastic strap tightening
Plastic strap - Black	2	To Squeeze the 2 cardboard sleeve together
Packaging label	3	White label with PN
Plastic strap- Green	2	To secure the enclosure to the wood pallet
Wood Pallet	1	2" deeper and 3" larger than enclosure size

1	880EB14	2	Eye Bolt M14 (Pack of 2)
1	9500U2D847824GP	0	9500U2D Gland Plate
1	880INT1	4	880 INT1 - Interlock Post Kit
10	STK-Q-07320	0	Flange Lock Nut M10
1	9500U2D847824IP	0	9500U2D 84" x 77.75" Inner Panel
10	STK-Q-07620	0	M10 Plastic Spacer 0.875"
8	STK-Q-04050-10	8	M6 x 10mm Hexagon Socket Head Machine Screw with Nyseal
1	9500U2D847824FD	0	9500U2D 84" x 77.75" Lock Door
1	9500U2D847824LD	0	9500U2D 84" x 77.75" Lock Door
1	9500U2D847824B	0	9500U2D 84" x 77.75" x 24" Body
Qty	Part Number	Rev	Description
Parts List			

Customer Client	Date
Drawn By Dessiné Par	Date 15-Apr-22
BoxCad: BoxCad	
Material Matière	12 Ga Cold Rolled A1008 CS Type B (2.5mm)
Color Couleur	Asa-61 Grey
Finish Fini	Smooth
Description	Detail Rev.
9500U2D 84" x 77.75" x 24" Assembly	
Part Number Numéro Pièce	Rev. 2
9500U2D847824	0
	17

This drawing is confidential and must not be reproduced or used without the consent of EXM

Ce dessin est confidentiel et ne doit pas être reproduit ou utilisé sans le consentement de EXM

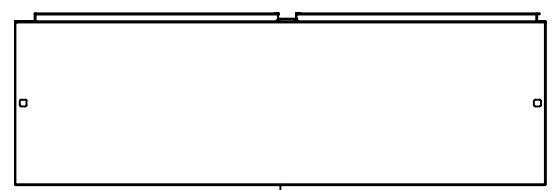

TOP

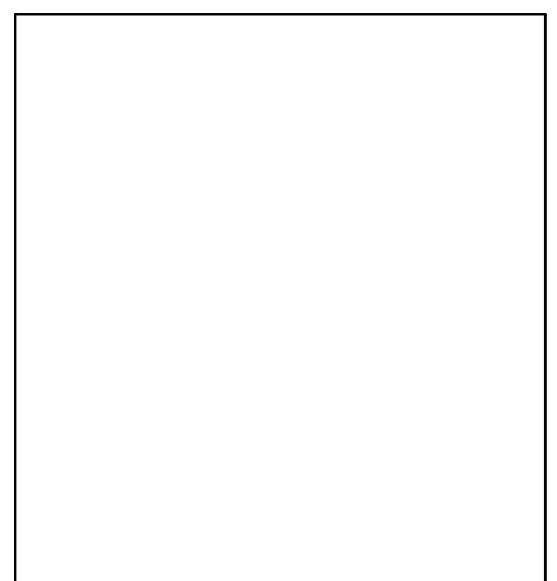

BACK

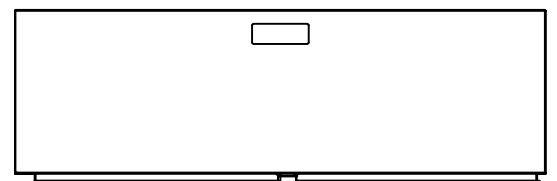

BOTTOM

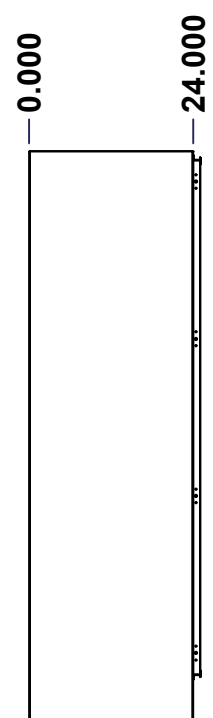

LEFT

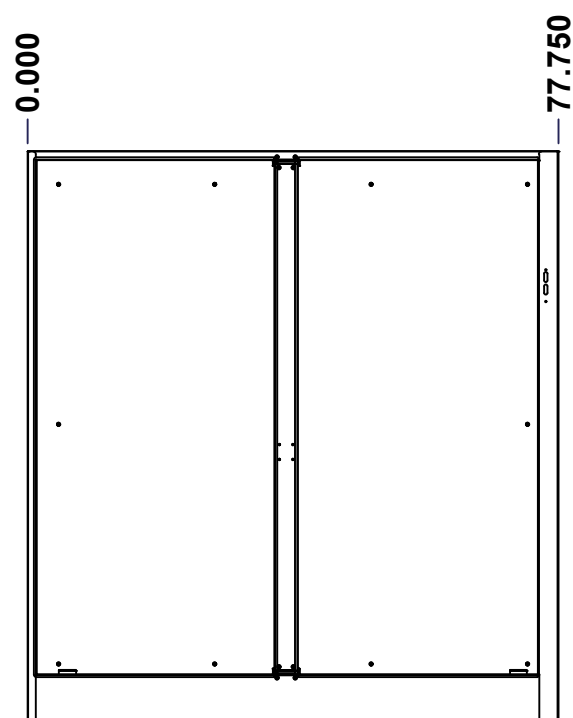

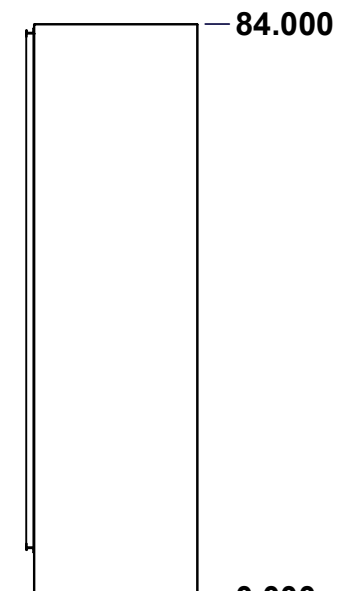

FRONT

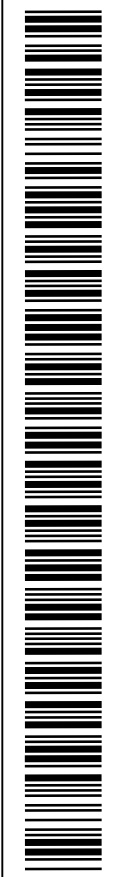
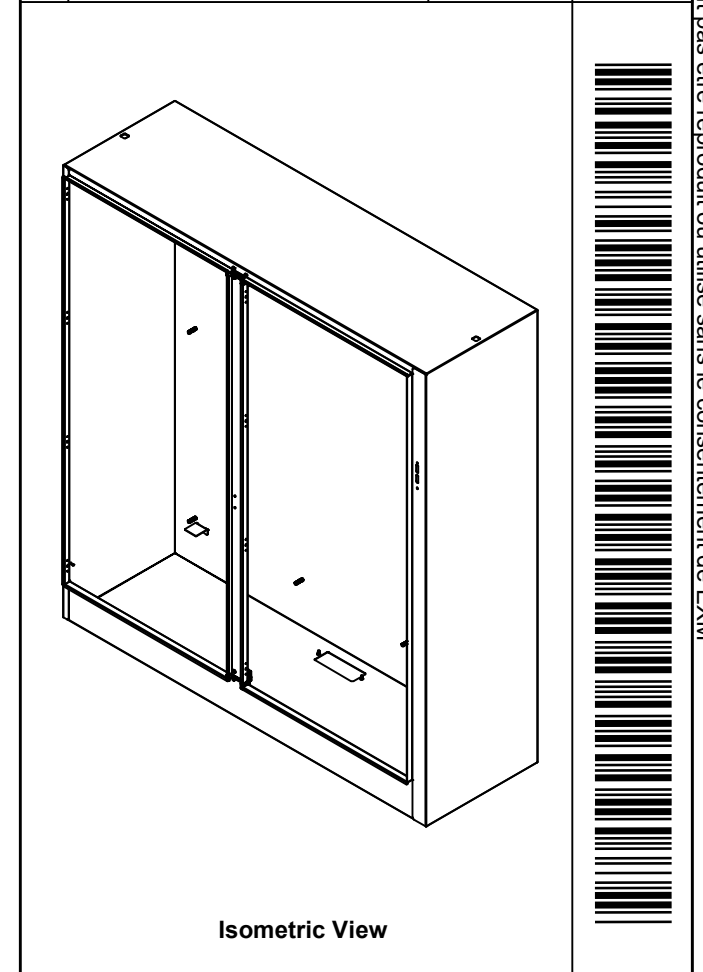

RIGHT

No.	Revisions	Date	By/Par

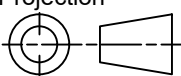

 Tél: (450) 979-4373 Fax: (450) 979-4626 www.exmweb.com		Flatness Aplatissement Max 3.0mm Projection 
Customer Client	Date	
Drawn By Dessiné Par	BoxCad: BoxCad	Date 15-Apr-22
Material Matière	12 Ga Cold Rolled A1008 CS Type B (2.5mm)	
Color Couleur	Asa-61 Grey	Finish Fini Smooth
Description	Detail Rev.	
9500U2D 84" x 77.75" x 24" Body		
Part Number Numéro Pièce	Rev. 0	3 / 17
9500U2D847824B		

SEE BILL OF MATERIAL ON LAST PAGE

This drawing is confidential and must not be reproduced or used without the consent of EXM

Ce dessin est confidentiel et ne doit pas être reproduit ou utilisé sans le consentement de EXM

STANDARD FEATURES ARE NOT LISTED IN THIS HOLE TABLE

HOLE TABLE - TOP VIEW (CUSTOM FEATURE ONLY)

CUT-OUT	XDIM	YDIM	DESCRIPTION
1	19.438	20.000	Struts CR400 33.500" (Inside)
2	58.313	20.000	Struts CR400 33.500" (Inside)
3	19.438	20.929	STUDS M6 x 10mm (Inside)
4	36.304	20.000	STUDS M6 x 10mm (Inside)
5	58.313	20.929	STUDS M6 x 10mm (Inside)
6	75.179	20.000	STUDS M6 x 10mm (Inside)

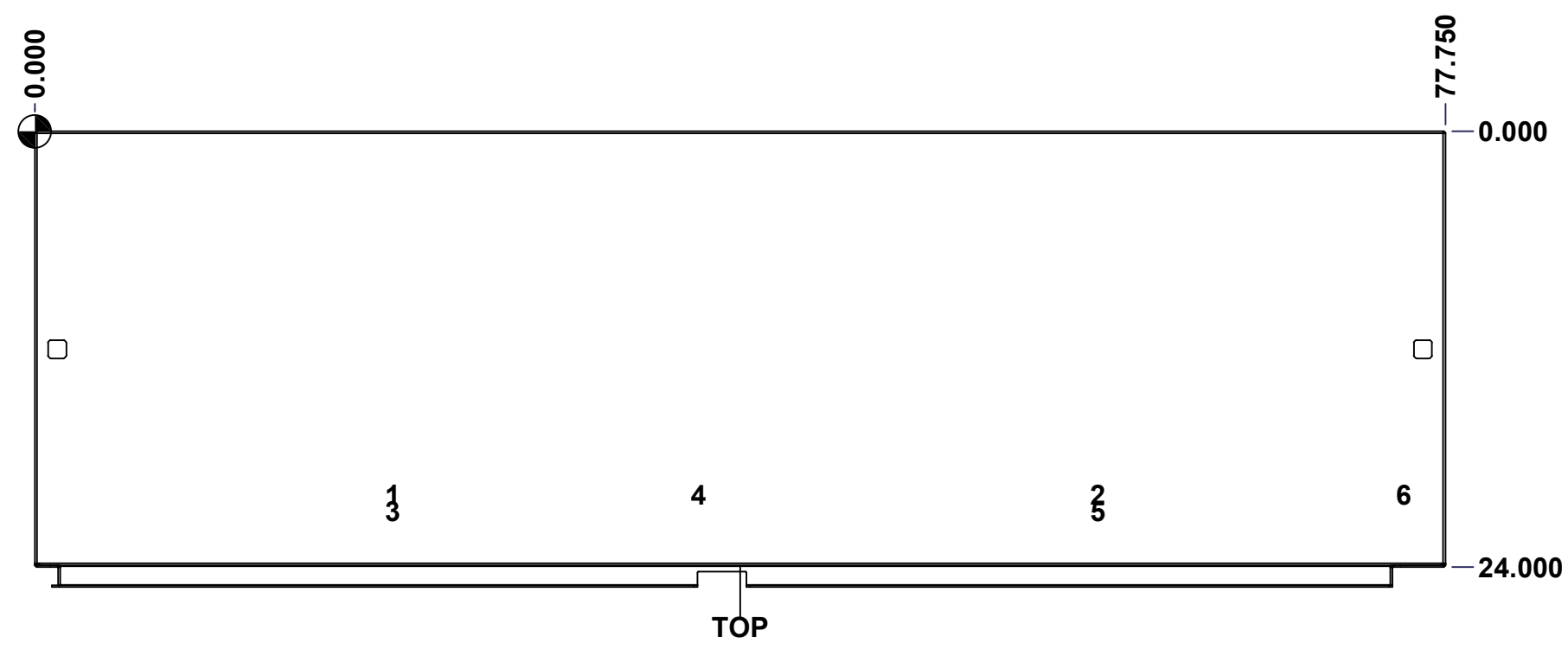

	Description	Status	
	9500U2D 84" x 77.75" x 24" Body	(NULL)	
	Part Number Numéro Pièce	Rev.	
	9500U2D847824B	0	4 17

This drawing is confidential and must not be reproduced or used without the consent of EXM

Ce dessin est confidentiel et ne doit pas être reproduit ou utilisé sans le consentement de EXM

STANDARD FEATURES ARE NOT LISTED IN THIS HOLE TABLE			
HOLE TABLE - BOTTOM VIEW (CUSTOM FEATURE ONLY)			
CUT-OUT	XDIM	YDIM	DESCRIPTION
1	34.250	3.500	GP STUD M6 x 16mm (Inside)
2	43.500	3.500	GP STUD M6 x 16mm (Inside)

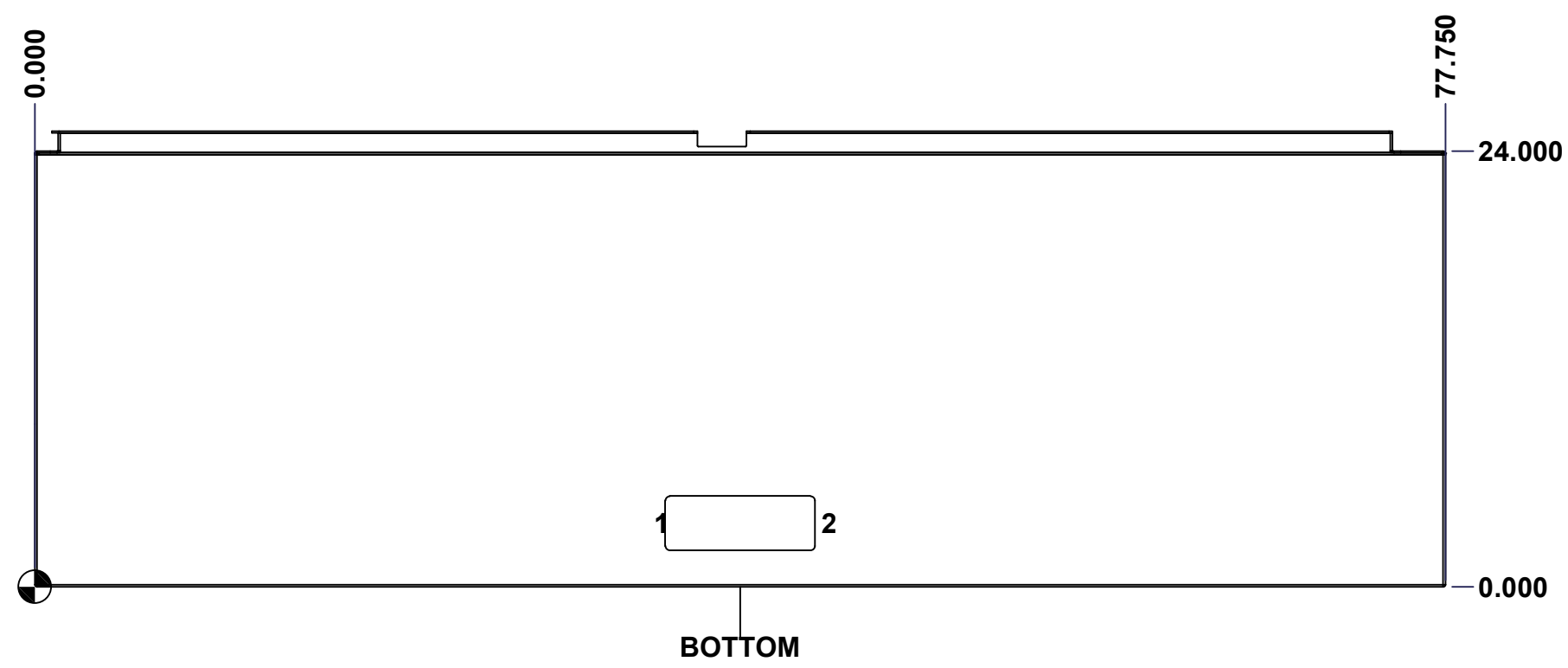

	Description	Status
	9500U2D 84" x 77.75" x 24" Body	(NULL)
	Part Number Numéro Pièce	Rev. 5
	9500U2D847824B	0 / 17

This drawing is confidential and must not be reproduced or used without the consent of EXM

Ce dessin est confidentiel et ne doit pas être reproduit ou utilisé sans le consentement de EXM

STANDARD FEATURES ARE NOT LISTED IN THIS HOLE TABLE			
HOLE TABLE - LEFT VIEW (CUSTOM FEATURE ONLY)			
CUT-OUT	XDIM	YDIM	DESCRIPTION
1	22.500	9.375	GND STUD M6 x 16mm (Inside)

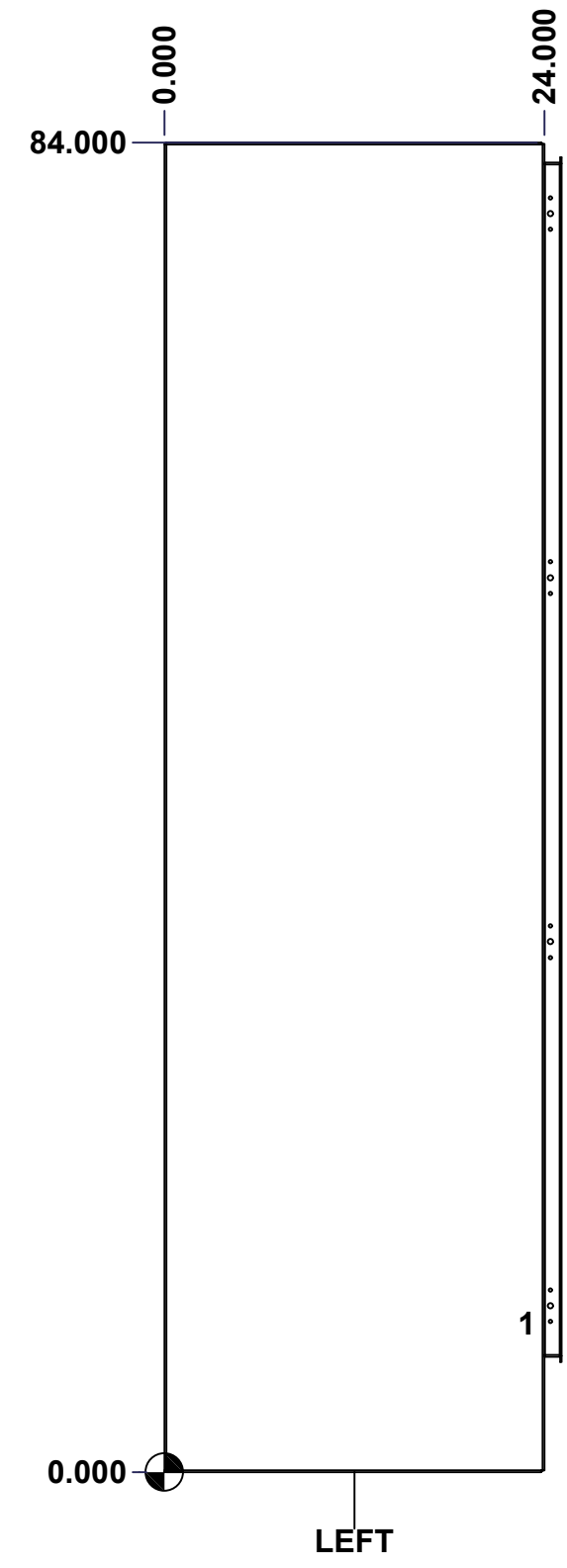

	Description	Status	
	9500U2D 84" x 77.75" x 24" Body	(NULL)	
	Part Number Numéro Pièce	Rev.	
	9500U2D847824B	0	6 17

This drawing is confidential and must not be reproduced or used without the consent of EXM

Ce dessin est confidentiel et ne doit pas être reproduit ou utilisé sans le consentement de EXM

STANDARD FEATURES ARE NOT LISTED IN THIS HOLE TABLE

HOLE TABLE - BACK VIEW (CUSTOM FEATURE ONLY)

CUT-OUT	XDIM	YDIM	DESCRIPTION
1	4.550	8.875	IP STUD M10 x 40mm (Inside)
2	73.200	8.875	IP STUD M10 x 40mm (Inside)
3	4.550	79.125	IP STUD M10 x 40mm (Inside)
4	73.200	79.125	IP STUD M10 x 40mm (Inside)
5	4.550	44.000	IP STUD M10 x 40mm (Inside)
6	73.200	44.000	IP STUD M10 x 40mm (Inside)
7	27.433	8.875	IP STUD M10 x 40mm (Inside)
8	50.317	8.875	IP STUD M10 x 40mm (Inside)
9	27.433	79.125	IP STUD M10 x 40mm (Inside)
10	50.317	79.125	IP STUD M10 x 40mm (Inside)
-----	-----	-----	-----
11	5.875	7.500	IP SUPPORT ANGLE (Inside)
12	71.875	7.500	IP SUPPORT ANGLE (Inside)

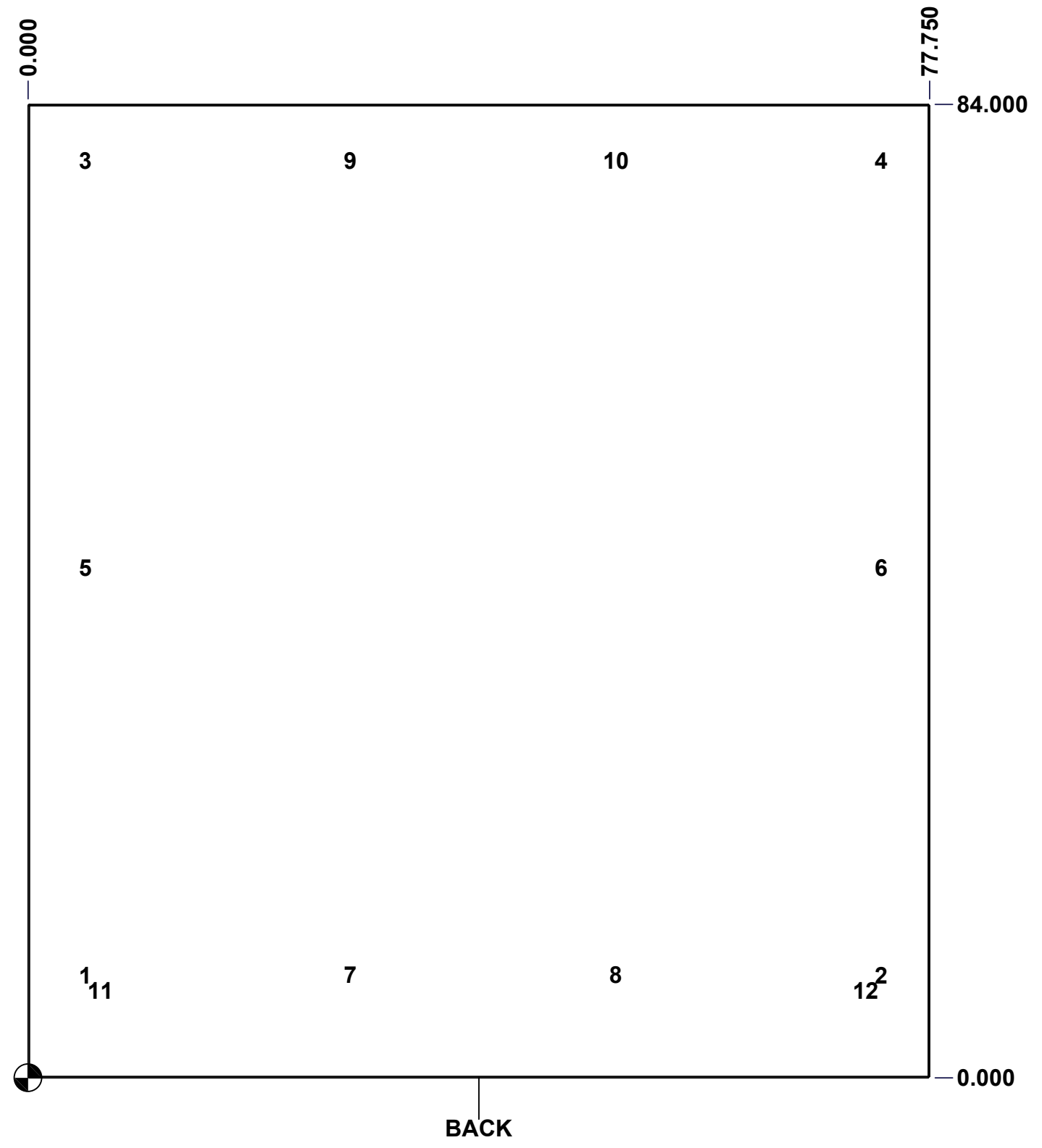

	Description	Status
	9500U2D 84" x 77.75" x 24" Body	(NULL)
Part Number Numéro Pièce 9500U2D847824B	Rev.	7
	0	17

This drawing is confidential and must not be reproduced or used without the consent of EXM

Ce dessin est confidentiel et ne doit pas être reproduit ou utilisé sans le consentement de EXM

STANDARD FEATURES ARE NOT LISTED IN THIS HOLE TABLE

HOLE TABLE - BACK VIEW (CUSTOM FEATURE ONLY)

CUT-OUT	XDIM	YDIM	DESCRIPTION
1	1.732	3.648	GND STUD M6 x 16mm (Inside)

2	0.748	31.138	PEM FH-M6-15ZI (Inside)
3	0.748	33.264	PEM FH-M6-15ZI (Inside)
4	2.717	31.138	PEM FH-M6-15ZI (Inside)
5	2.717	33.264	PEM FH-M6-15ZI (Inside)

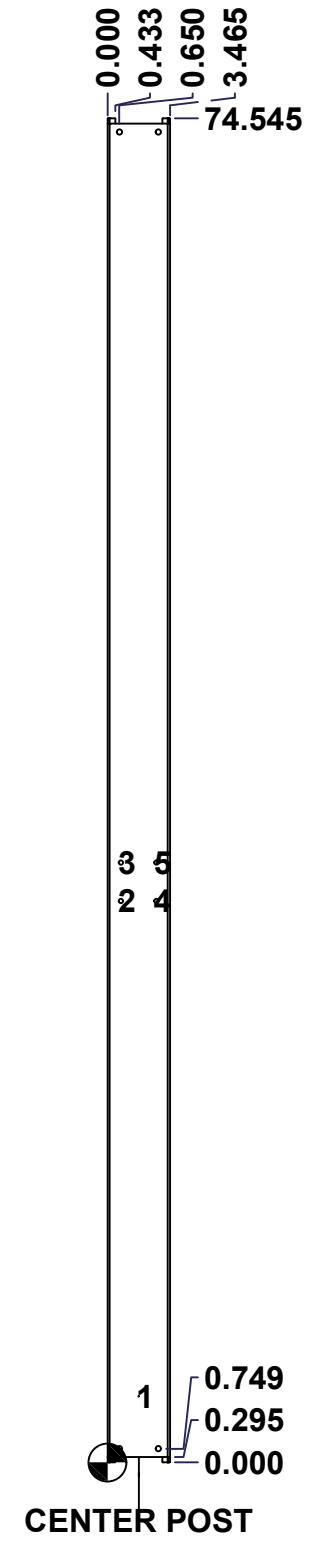

	Description	Status
	9500U2D 84" x 77.75" x 24" Body	(NULL)
	Part Number	Rev.
	Numéro Pièce	8
	9500U2D847824B	0
		17

This drawing is confidential and must not be reproduced or used without the consent of EXM

Ce dessin est confidentiel et ne doit pas être reproduit ou utilisé sans le consentement de EXM

No.	Revisions	Date	By/Par

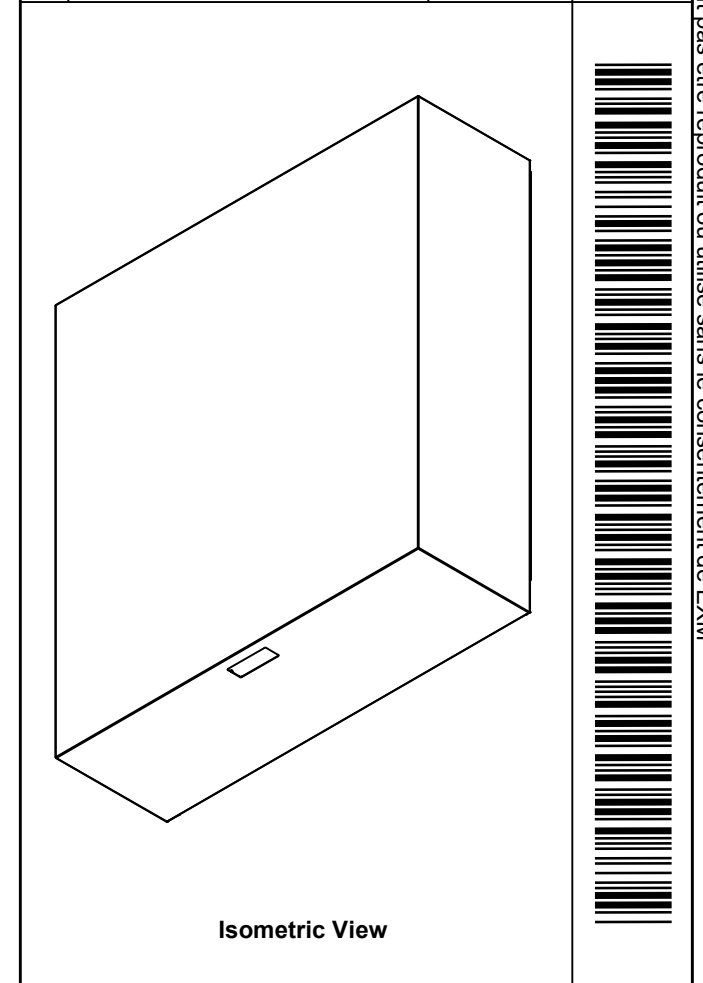

Isometric View

4	STK-PEM-FH-M6-15ZI	0	PEM Self-Clinching Stud M6 x 15.0mm
4	STK-Q-16030	0	Stud M6 x 10mm Steel
2	9500U2D847824BPA-P	0	9500U2D Inner Panel Support Angle
1	STK-P-02400S	0	Powder Paint (Asa-61 Grey / Smooth)
2	STK-Q-74910	0	Eyebolt Lifting Angle (15.500")
1	STK-A-75454	3	Center Post - Sealing Block with Latch Assembly (Large)
1	9500U2D847824CP-P	0	9500U2D 84" Center Post Part
10	STK-Q-16100	0	Stud M10 x 40mm Steel
1	9500U2D847824B-P	0	9500U2D 84" x 77.75" Body Part
2	9500U2D847824_CR400 MS_33.5	0	Commercial Roll Mild Steel (33.5in long)
4	STK-Q-16080	0	Ground Stud M6 x 16mm Steel

Qty	Part Number	Rev	Description
Parts List			

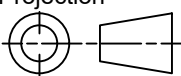
 Tél: (450) 979-4373 Fax: (450) 979-4626 www.exmweb.com		Flatness Aplatissement Max 3.0mm Projection 
Customer Client	Date	
Drawn By Dessiné Par	BoxCad: BoxCad	Date 15-Apr-22
Material Matière	12 Ga Cold Rolled A1008 CS Type B (2.5mm)	
Color Couleur	Asa-61 Grey	Finish Fini Smooth
Description		Detail Rev.
9500U2D 84" x 77.75" x 24" Body		
Part Number Numéro Pièce	Rev.	9
9500U2D847824B	0	17

This drawing is confidential and must not be reproduced or used without the consent of EXM

Ce dessin est confidentiel et ne doit pas être reproduit ou utilisé sans le consentement de EXM

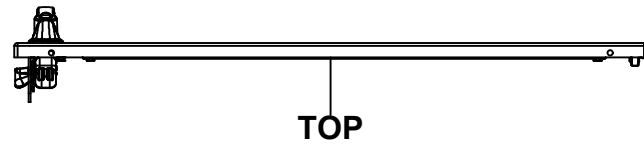

TOP

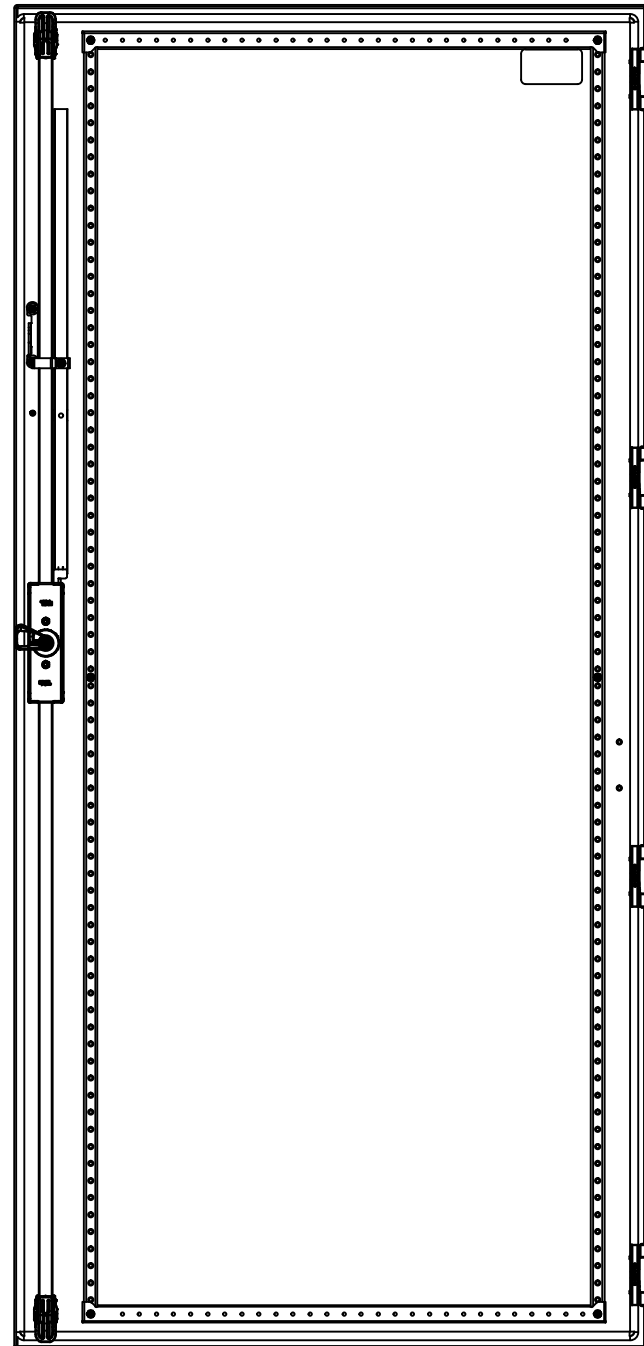

BACK



BOTTOM

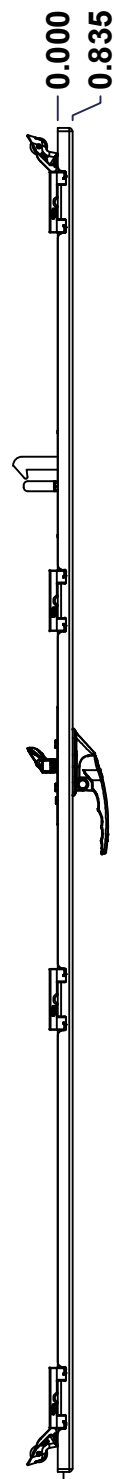

LEFT

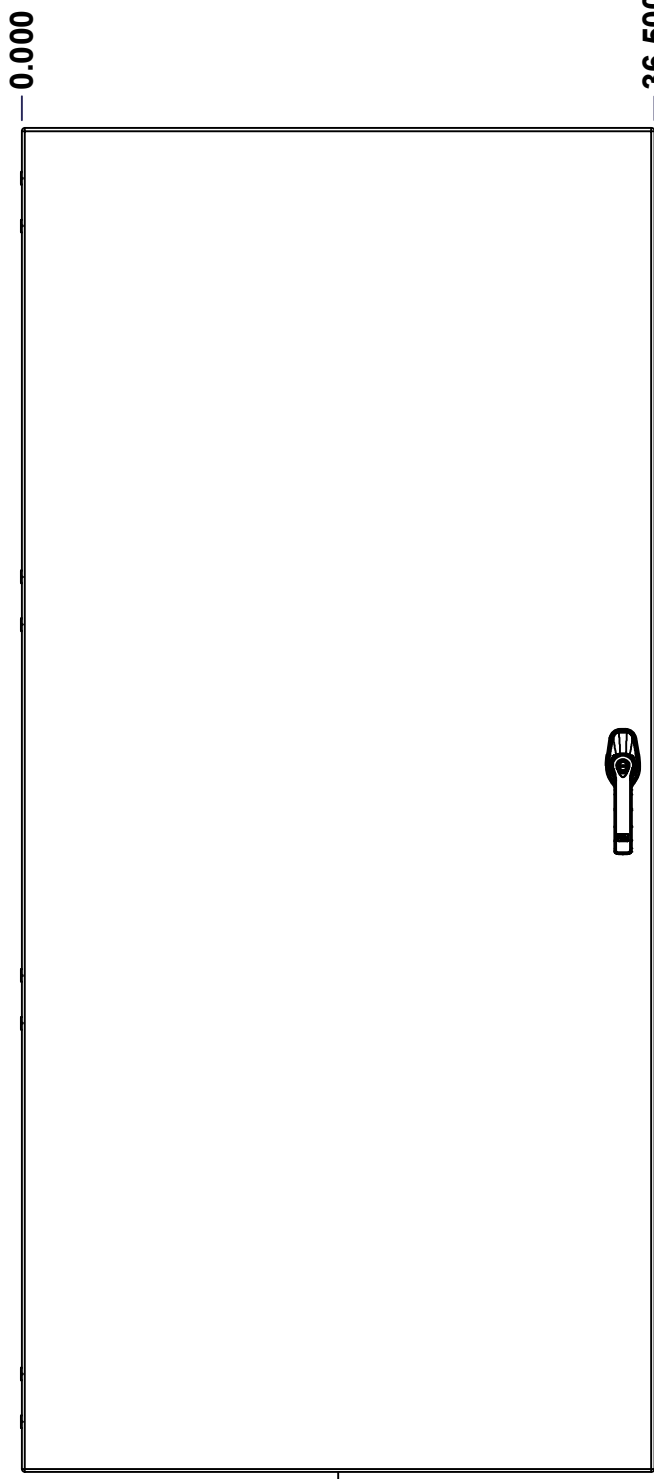

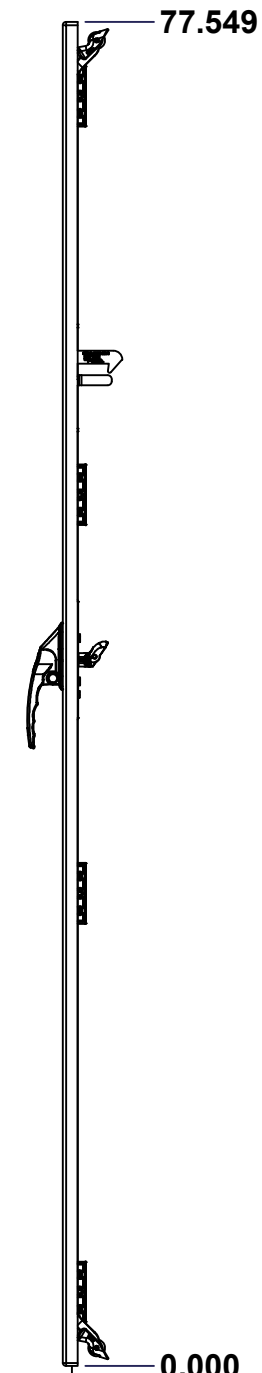

FRONT

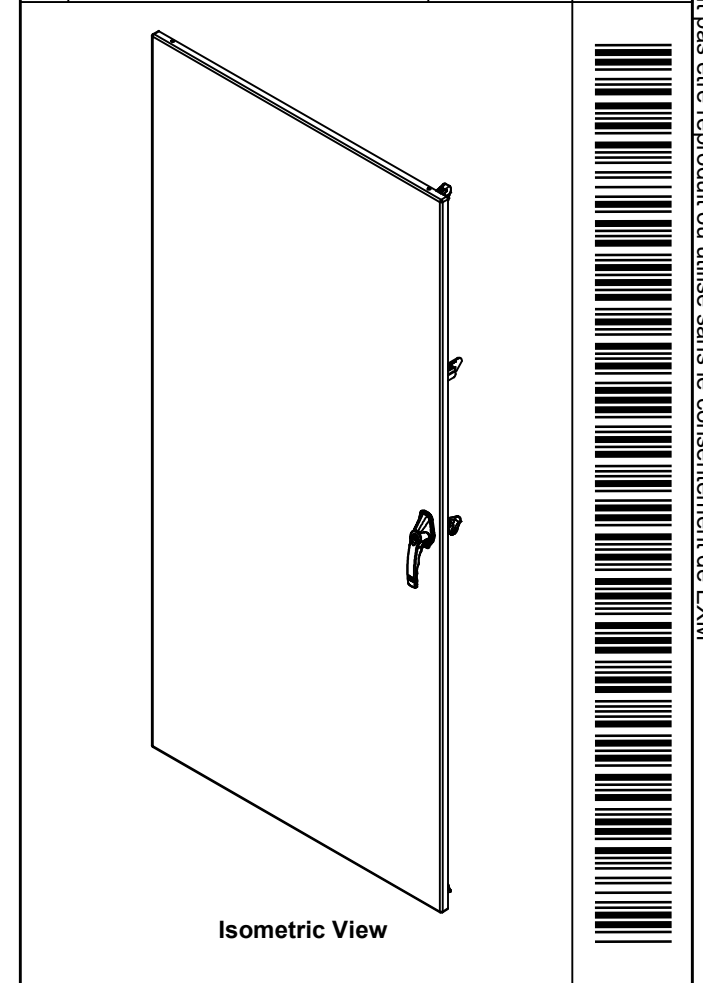

RIGHT

No.	Revisions	Date	By/Par

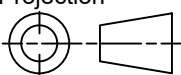

 Tél: (450) 979-4373 Fax: (450) 979-4626 www.exmweb.com		Flatness Aplatissement
		Max 3.0mm
Customer Client Drawn By / Dessiné Par: BoxCad: BoxCad Material / Matière: 12 Ga Cold Rolled A1008 CS Type B (2.5mm)		Projection
		
Date		Date
Date 15-Apr-22		Date
Color / Couleur: Asa-61 Grey		Finish / Fini: Smooth
Description: 9500U2D 84" x 77.75" Lock Door		Detail Rev.
Part Number / Numéro Pièce: 9500U2D847824LD		Rev. 10
SEE BILL OF MATERIAL ON LAST PAGE		0 17

This drawing is confidential and must not be reproduced or used without the consent of EXM

Ce dessin est confidentiel et ne doit pas être reproduit ou utilisé sans le consentement de EXM

STANDARD FEATURES ARE NOT LISTED IN THIS HOLE TABLE

HOLE TABLE - FRONT VIEW (CUSTOM FEATURE ONLY)

CUT-OUT	XDIM	YDIM	DESCRIPTION
1	35.455	60.011	STUD M6 x 18mm (Inside)
2	35.455	57.011	STUD M6 x 18mm (Inside)
3	35.455	54.011	STUD M6 x 18mm (Inside)
4	34.678	6.179	LARGE CBAR GUIDE (Inside)
5	34.678	71.370	LARGE CBAR GUIDE (Inside)
6	33.822	69.870	LARGE CBAR GUIDE (Inside)
7	2.847	2.028	STUD M6 x 18mm (Inside)
8	2.847	38.760	STUD M6 x 18mm (Inside)
9	2.847	75.521	STUD M6 x 18mm (Inside)
10	32.098	2.028	STUD M6 x 18mm (Inside)
11	32.098	38.760	STUD M6 x 18mm (Inside)
12	32.098	75.521	STUD M6 x 18mm (Inside)

13	34.688	40.743	HANDLE 885 ESL2A-APHD @ 0.0°
14	1.610	32.363	STUDS M6 x 18mm (Inside)
15	1.610	35.041	STUDS M6 x 18mm (Inside)

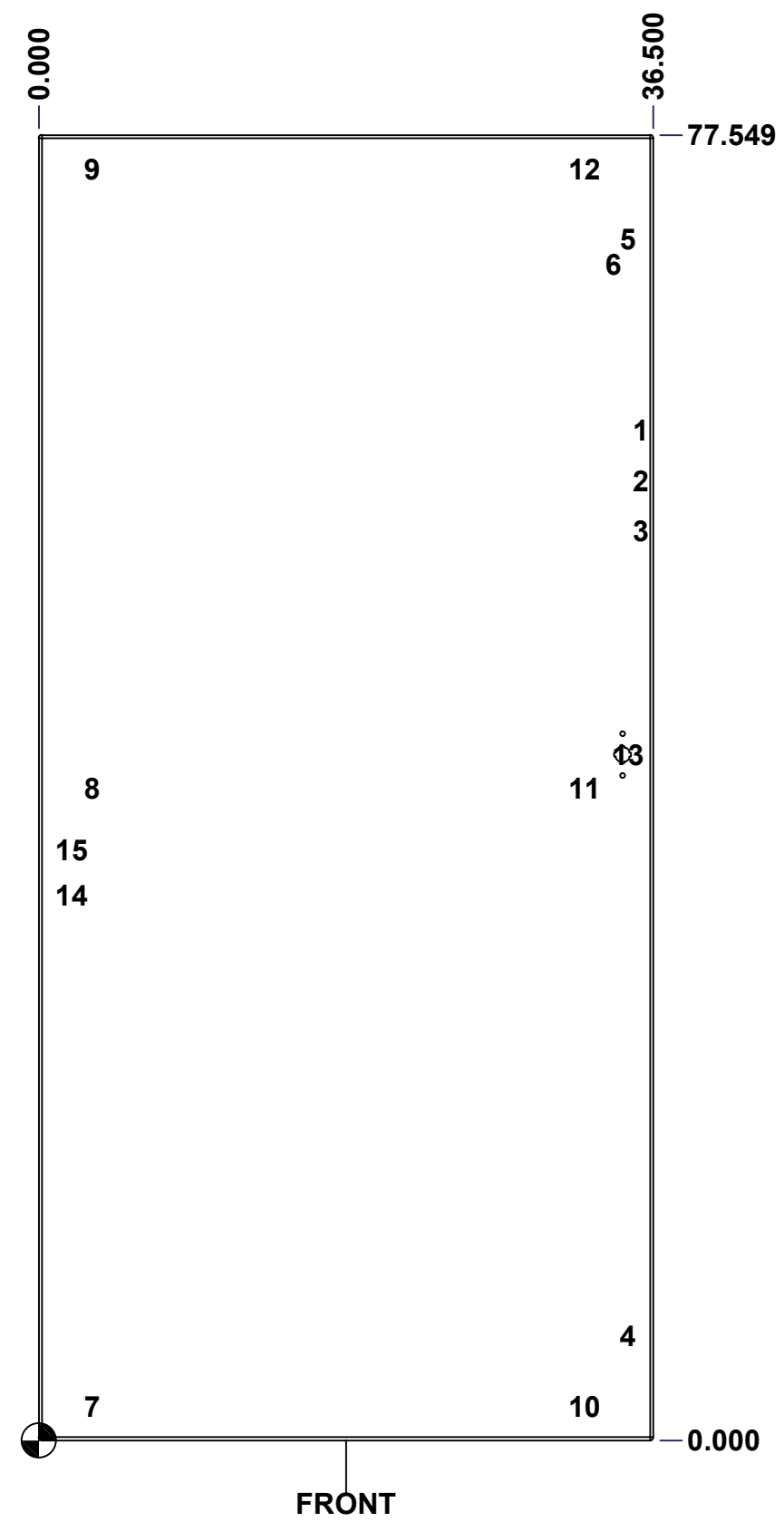

FRONT

	Description	Status
	9500U2D 84" x 77.75" Lock Door	(NULL)
	Part Number Numéro Pièce	Rev.
	9500U2D847824LD	0
		11
		17

This drawing is confidential and must not be reproduced or used without the consent of EXM

Ce dessin est confidentiel et ne doit pas être reproduit ou utilisé sans le consentement de EXM

No.	Revisions	Date	By/Par

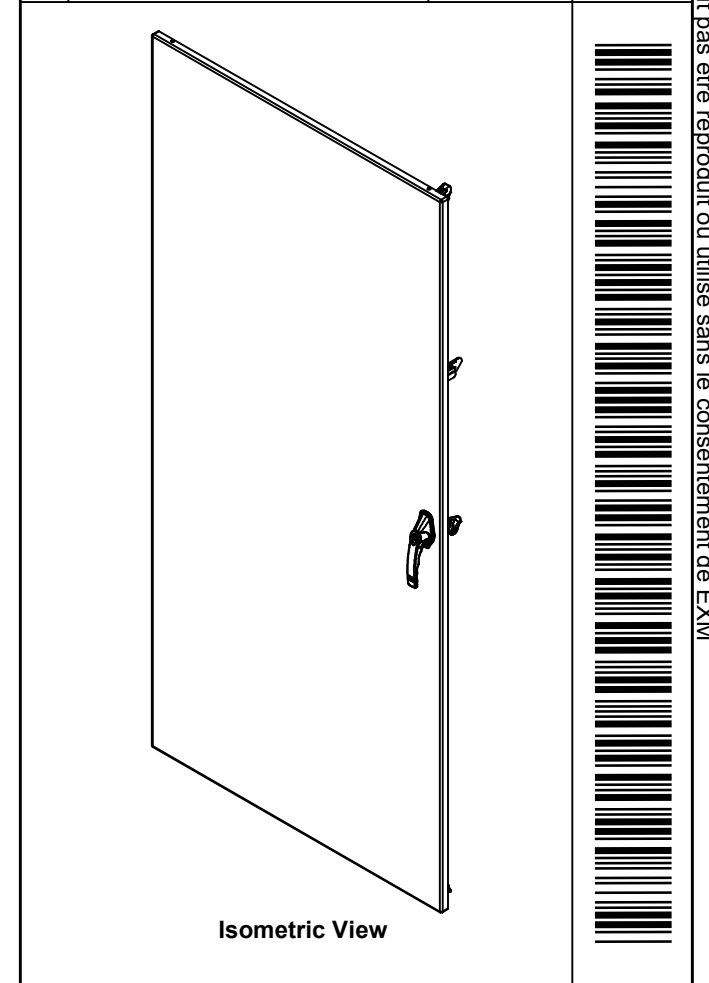

 Tél: (450) 979-4373
 Fax: (450) 979-4626
www.exmweb.com

Flatness / Aplatissement: Max 3.0mm
 Projection: 

1	STK-K-09584	0	9500 UxD 84" Locking Mechanism Kit
2	STK-Q-16050	1	Stud M6 x 18mm Steel
1	885ESL2A-APHD	1	885 ESL2A-APHD - Zinc Die Cast L-Handle Padlockable Assy - Slot Cylinder
1	STK-P-02400S	0	Powder Paint (Asa-61 Grey / Smooth)
1	STK-S-00100	0	3.5" x 2" Silver Milar Flexcon Sticker
1	9500U2D847824DS1	0	9500U2D 84" x 77.75" Door Stiffener
9	STK-Q-16055	1	M6 x 18mm Stud (No Paint Cap Required)
3	STK-Q-16410	0	Guide Stud - Largel (No Paint Cap Required)
4	STK-K-09860	7	Cabinet Hinge with Captive Pins
1	9500U2D847824LDG	0	9500U2D 84" x 77.75" Lock Door Gasket
1	9500U2D847824LD-P	0	9500U2D 84" x 77.75" Lock Door Part

Customer / Client	Date
Drawn By / Dessiné Par: BoxCad: BoxCad	Date: 15-Apr-22
Material / Matière: 12 Ga Cold Rolled A1008 CS Type B (2.5mm)	
Color / Couleur: Asa-61 Grey	Finish / Fini: Smooth
Description: 9500U2D 84" x 77.75" Lock Door	Detail Rev.
Part Number / Numéro Pièce: 9500U2D847824LD	Rev. 0

QTY	Part Number	Rev	Description
Parts List			

This drawing is confidential and must not be reproduced or used without the consent of EXM

Ce dessin est confidentiel et ne doit pas être reproduit ou utilisé sans le consentement de EXM



TOP

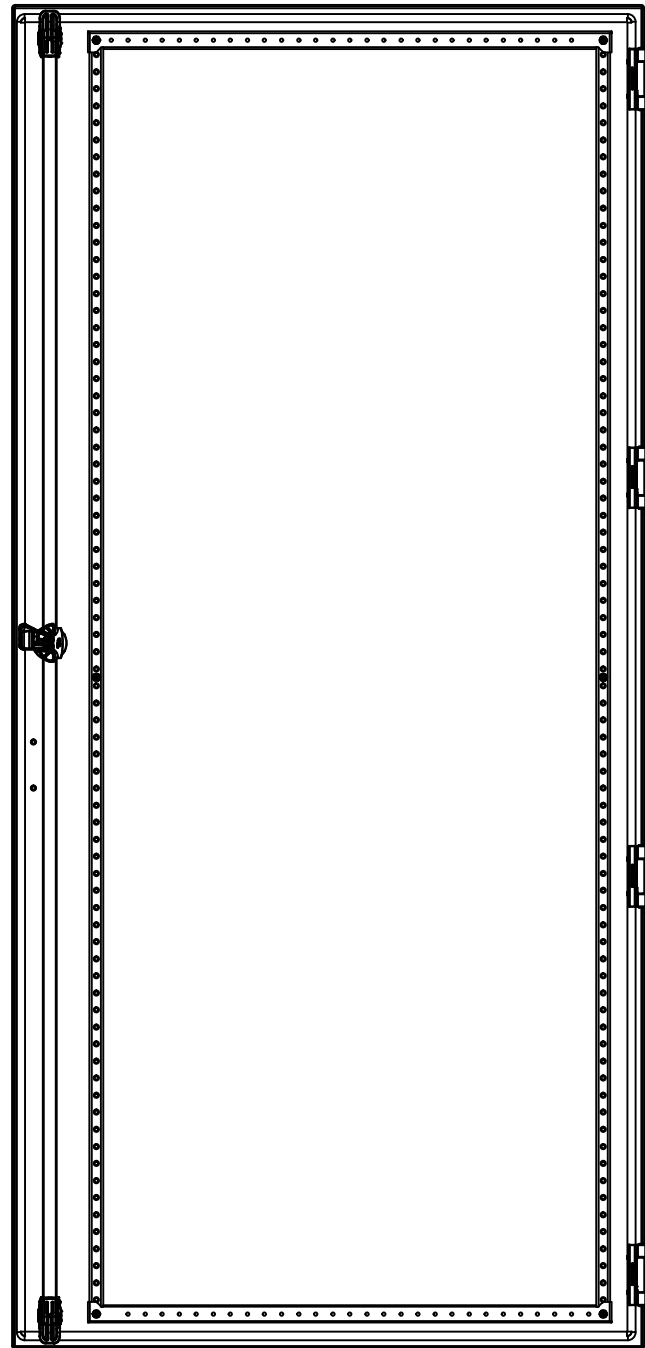

BACK



BOTTOM

0.000
0.835

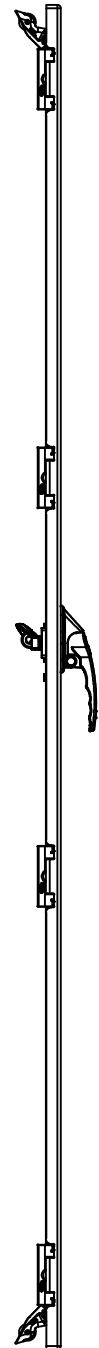

LEFT

0.000

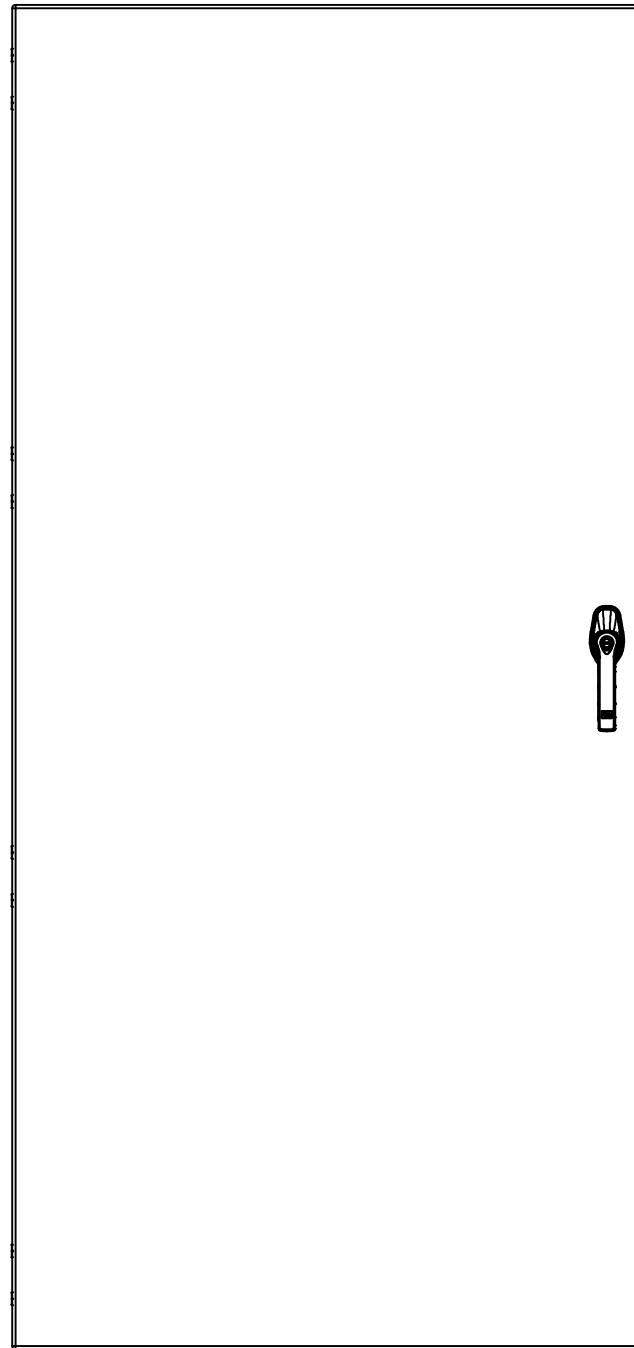

FRONT

36.500

77.549

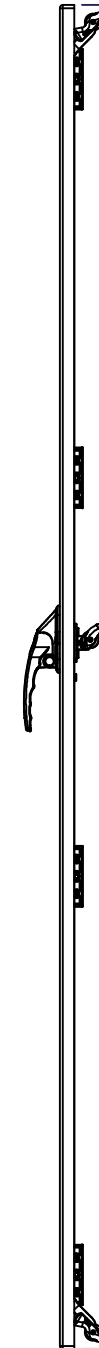

RIGHT

0.000

No.	Revisions	Date	By/Par

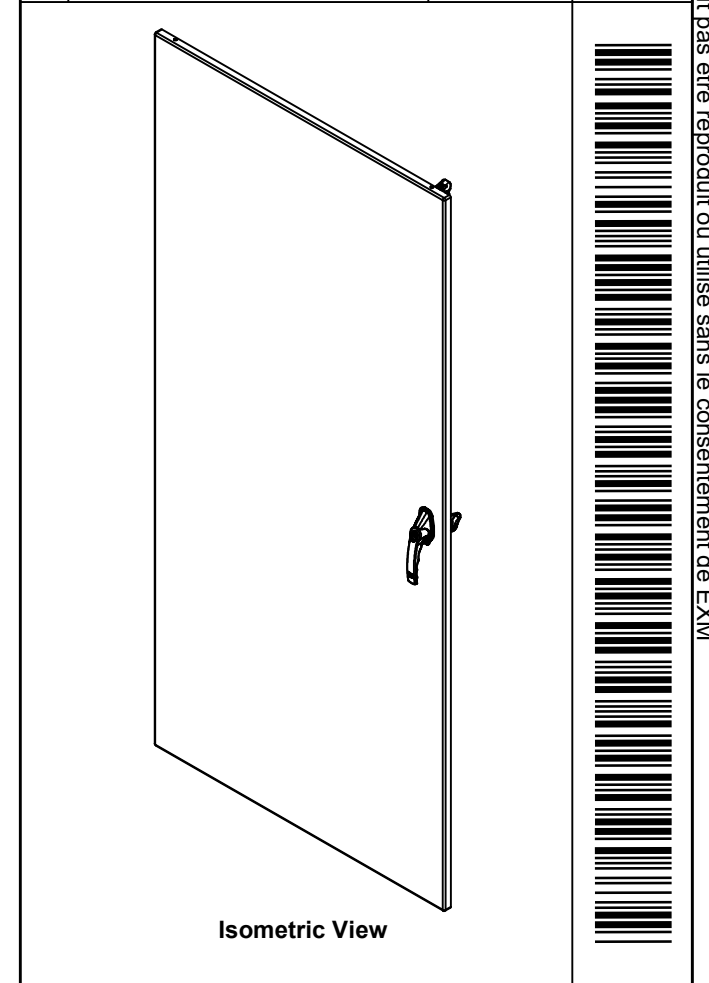

 Tél: (450) 979-4373 Fax: (450) 979-4626 www.exmweb.com		Flatness Aplatissement	
		Max 3.0mm	
Customer Client		Date	
Drawn By Dessiné Par BoxCad: BoxCad		Date 15-Apr-22	
Material Matière 12 Ga Cold Rolled A1008 CS Type B (2.5mm)			
Color Couleur Asa-61 Grey		Finish Fini Smooth	
Description 9500U2D 84" x 77.75" Lock Door			Detail Rev.
Part Number Numéro Pièce 9500U2D847824FD		Rev. 0	13 17

SEE BILL OF MATERIAL ON LAST PAGE

This drawing is confidential and must not be reproduced or used without the consent of EXM

Ce dessin est confidentiel et ne doit pas être reproduit ou utilisé sans le consentement de EXM

STANDARD FEATURES ARE NOT LISTED IN THIS HOLE TABLE

HOLE TABLE - FRONT VIEW (CUSTOM FEATURE ONLY)

CUT-OUT	XDIM	YDIM	DESCRIPTION
1	34.313	6.118	LARGE CBAR GUIDE (Inside)
2	34.313	71.431	LARGE CBAR GUIDE (Inside)
3	2.375	2.028	STUD M6 x 18mm (Inside)
4	2.375	38.760	STUD M6 x 18mm (Inside)
5	2.375	75.521	STUD M6 x 18mm (Inside)
6	31.626	2.028	STUD M6 x 18mm (Inside)
7	31.626	38.760	STUD M6 x 18mm (Inside)
8	31.626	75.521	STUD M6 x 18mm (Inside)

9	34.312	40.743	HANDLE 885 ESL2A-APHD @ 0.0°
10	35.247	32.363	STUDS M6 x 18mm (Inside)
11	35.247	35.041	STUDS M6 x 18mm (Inside)

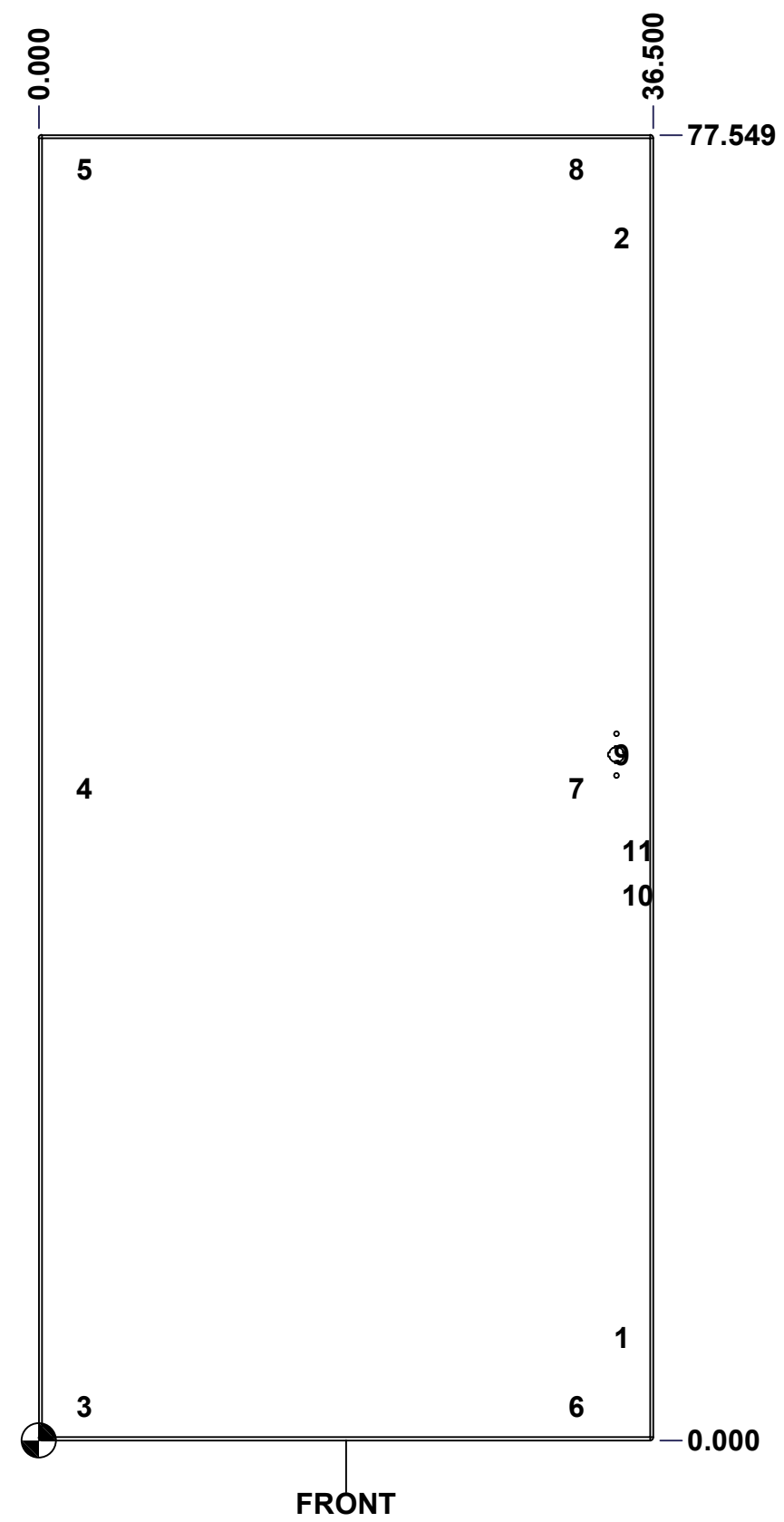

FRONT

	Description	Status
	9500U2D 84" x 77.75" Lock Door	(NULL)
	Part Number Numéro Pièce	Rev.
	9500U2D847824FD	0
		14
		17

This drawing is confidential and must not be reproduced or used without the consent of EXM

Ce dessin est confidentiel et ne doit pas être reproduit ou utilisé sans le consentement de EXM

No.	Revisions	Date	By/Par

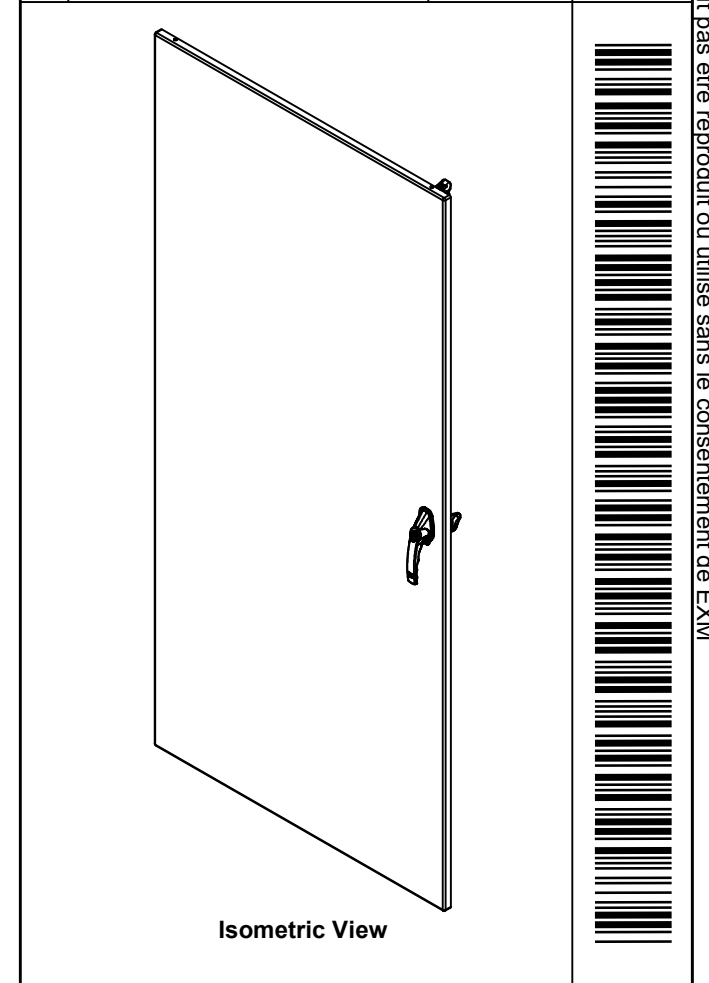

2	STK-Q-16050	1	Stud M6 x 18mm Steel
2	STK-Q-07220	1	M6 Nylon Insert Lock Nut
1	STK-Q-47560	0	9500 Lower Closing Bar 84"
2	STK-A-90025	3	9500 - Cabinet Closing Bar End (Large)
1	STK-Q-47550	0	9500 Upper Closing Bar 84"
1	STK-Q-90051	3	5412 ES - Handle Cam Spacer
1	STK-A-50538	3	9500 Handle Cam Assembly (Right Side, Grip 36mm)
1	885ESL2A-APHD	1	885 ESL2A-APHD - Zinc Die Cast L-Handle Padlockable Assy - Slot Cylinder
1	STK-P-02400S	0	Powder Paint (Asa-61 Grey / Smooth)
1	9500U2D847824DS1	0	9500U2D 84" x 77.75" Door Stiffener
6	STK-Q-16055	1	M6 x 18mm Stud (No Paint Cap Required)
2	STK-Q-16410	0	Guide Stud - Largel (No Paint Cap Required)
4	STK-K-09860	7	Cabinet Hinge with Captive Pins
1	9500U2D847824FDG	0	9500U2D 84" x 77.75" Flange Door Gasket
1	9500U2D847824FD-P	0	9500U2D 84" x 77.75" Lock Door Part

QTY	Part Number	Rev	Description
Parts List			

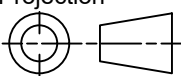
 Tél: (450) 979-4373 Fax: (450) 979-4626 www.exmweb.com		Flatness Aplatissement Max 3.0mm
Projection 		Customer Client
Drawn By Dessiné Par BoxCad: BoxCad		Date 15-Apr-22
Material Matière 12 Ga Cold Rolled A1008 CS Type B (2.5mm)		
Color Couleur Asa-61 Grey	Finish Fini Smooth	
Description 9500U2D 84" x 77.75" Lock Door		Detail Rev.
Part Number Numéro Pièce 9500U2D847824FD		Rev. 15 0 17

This drawing is confidential and must not be reproduced or used without the consent of EXM

Ce dessin est confidentiel et ne doit pas être reproduit ou utilisé sans le consentement de EXM

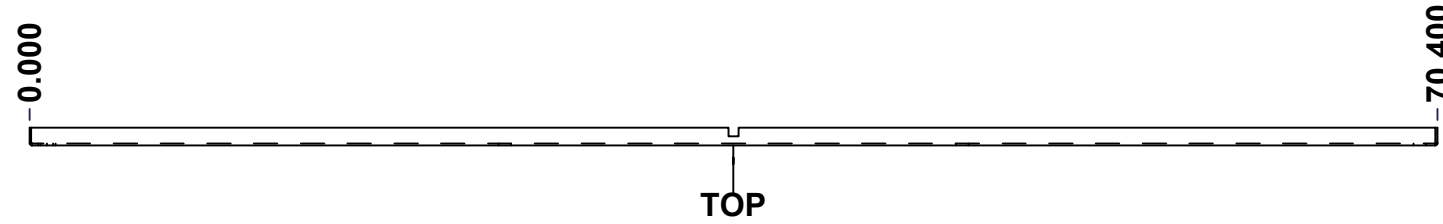

TOP

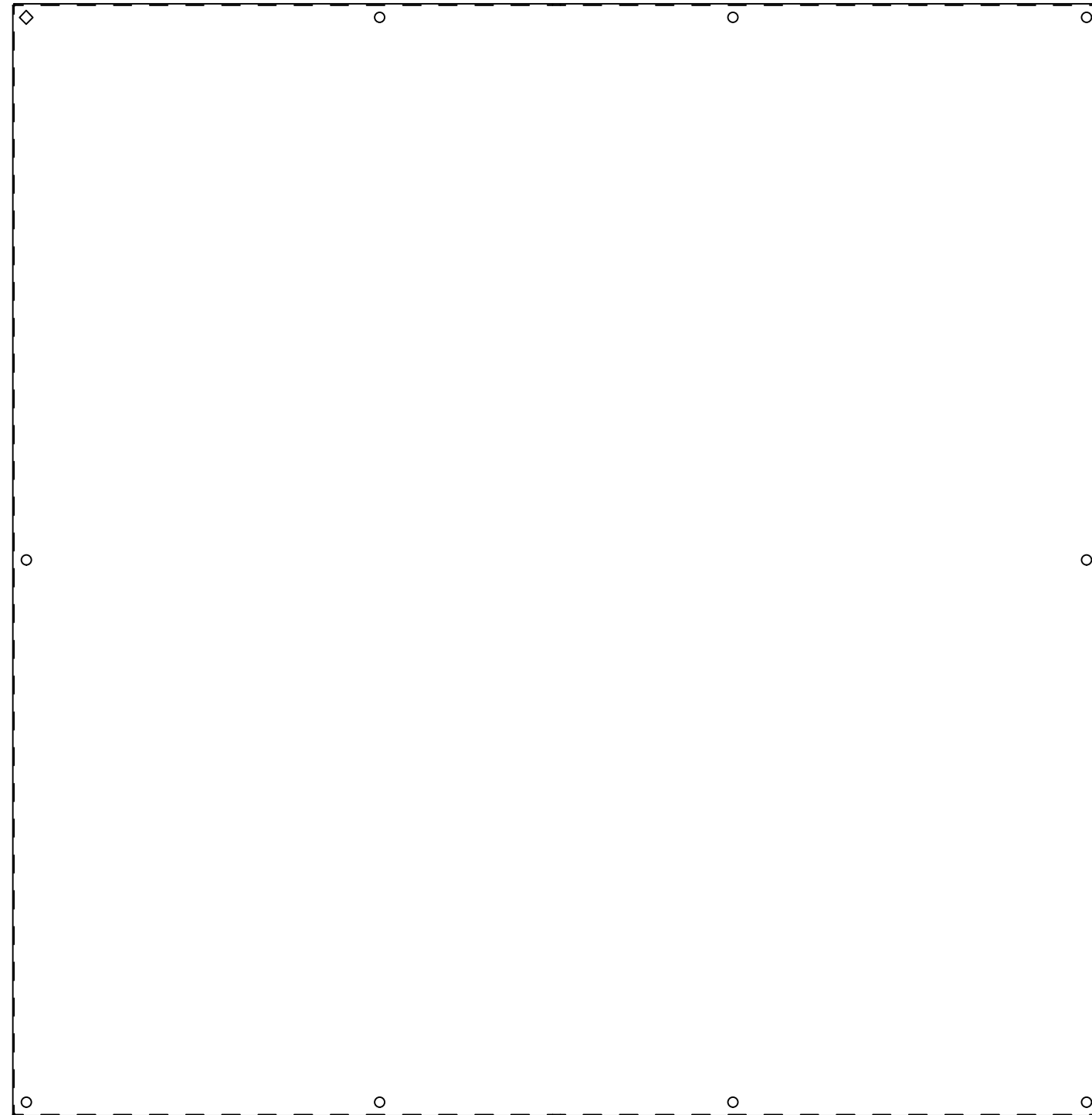

FRONT

72.000

0.000

RIGHT

SEE BILL OF MATERIAL ON LAST PAGE

No.	Revisions	Date	By/Par

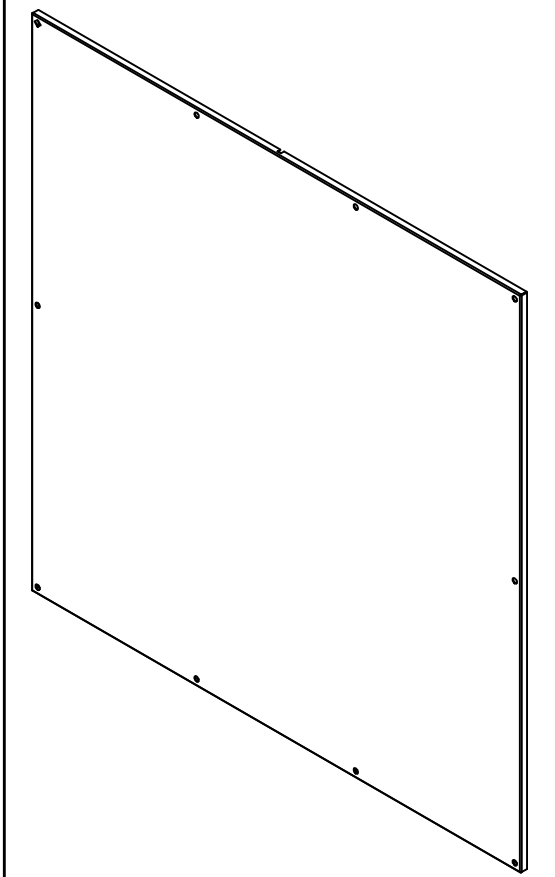

Isometric View

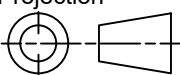

 Tél: (450) 979-4373 Fax: (450) 979-4626 www.exmweb.com	Flatness Aplatissement Max 3.0mm
	Projection 
Customer Client	Date
Drawn By Dessiné Par BoxCad: BoxCad	Date 15-Apr-22
Material Matière 12 Ga Cold Rolled A1008 CS Type B (2.5mm)	
Color Couleur White RAL9003	Finish Fini Smooth
Description 9500U2D 84" x 77.75" Inner Panel	
Part Number Numéro Pièce 9500U2D847824IP	Detail Rev. Rev. 16 0

This drawing is confidential and must not be reproduced or used without the consent of EXM

Ce dessin est confidentiel et ne doit pas être reproduit ou utilisé sans le consentement de EXM

No.	Revisions	Date	By/Par

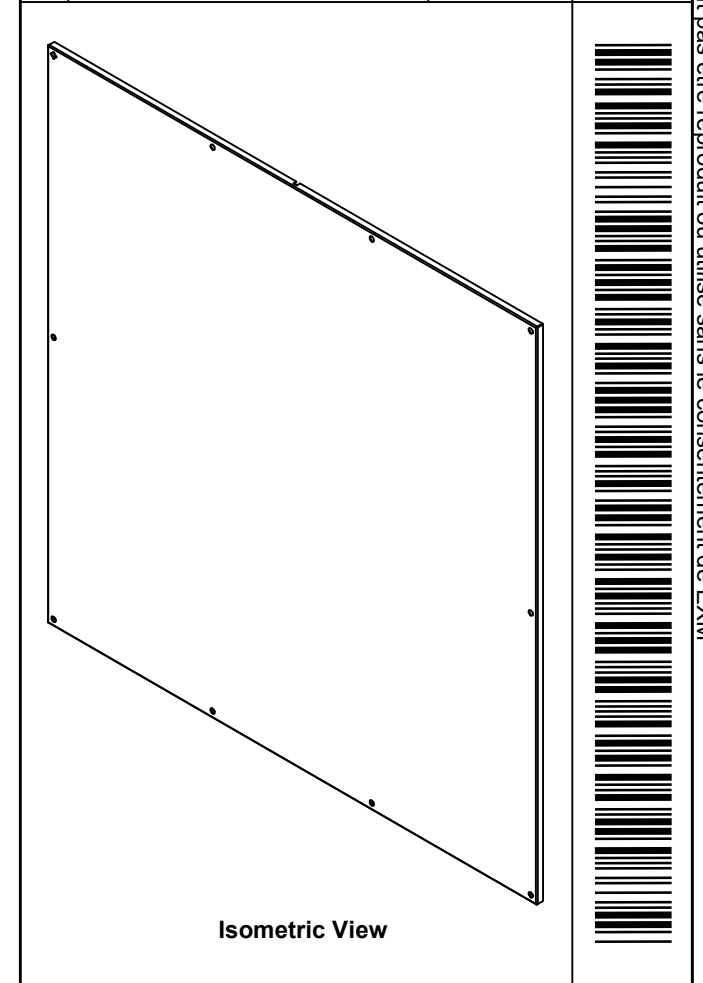

Tél: (450) 979-4373 Fax: (450) 979-4626 www.exmweb.com		Flatness Aplatissement
		Max 3.0mm
Customer Client		Date
Drawn By Dessiné Par	BoxCad: BoxCad	Date 15-Apr-22
Material Matière 12 Ga Cold Rolled A1008 CS Type B (2.5mm)		
Color Couleur	White RAL9003	Finish Fini Smooth
Description 9500U2D 84" x 77.75" Inner Panel		Detail Rev.
Part Number Numéro Pièce 9500U2D847824IP		Rev. 17 0 17

Qty	Part Number	Rev	Description
1	STK-P-02401S	0	Powder Paint (White / Smooth)
1	9500U2D847824IP-P	0	9500U2D 84" x 77.75" Inner Panel Part
Parts List			